











Sean Fisher  
 Chris Gibson  
 Marwan Kamleh  
 Samantha Lafrance  
 Jacob Moore

## T306: Operation Manual

### Prototype: Material Acquisition

This manual will be used to construct and assemble the charging station prototype as outlined. The first step is procurement of the necessary materials. This is outlined below in the Bill of Materials table.

Part #	Vendor/Supplier	Description	Qty	Units	Picture	Unit Cost	Cost
53110	Nature Power	110W Panel kit w/ Charge Controller, Panel, mounting z-brackets, and inverter	1	1		\$ 220.00	\$ 220.00
RBT100G	Renogy	Hybrid GEL battery 12V, 100Ah	1	1		\$ 246.00	\$ 246.00
2HGR7	GRAINGER	Aluminum Plate 24"x24"	1	1		\$ 295.80	\$ 295.80
5GUL0	Rigid	Aluminum Conduit 3" Diam 10' length	1	1		\$121.28	\$ 121.28
67312	Hillman	1/2" x 5" Hex Bolt	4	1		\$2.07	\$ 8.28
67342	Hillman	1/2" Hex Nut	4	1		\$0.41	\$ 1.64
63449	Hillman	0.531" Flat Washer	4	1		\$0.36	\$ 1.44
61817	Hillman	1/2" Split Lock Washer	4	1		\$0.28	\$ 1.12
20670	Aluminum Bar	1/2" x 8" Aluminum Rectangle Bar 3'	1	1		\$87.00	\$ 87.00
1171	Aluminum Bar	1/2" x 4" Aluminum Rectangle Bar 6'	1	1		\$ 76.49	\$ 76.49
	<b>Total</b>		<b>22</b>				<b>\$ 1,059.05</b>

All materials saved for the Solar Kit and Battery are referenced to Grainger Industrial Supply, found at <https://www.grainger.com/>. The Solar Kit can be found on respective websites, or at hardware stores such as Home Depot, Lowes, and Northern Tool and Equipment. The battery can be found on its website at <https://www.renogy.com/deep-cycle-hybrid-gel-battery-12-volt-100ah/>. All have been confirmed to have the products upon the writing of this manual.

## Prototype: Base Construction

This section pertains to the construction of the base frame below, including the hardware used for mounting, and the framing to facilitate the electrical components. To construct, there is a required welder for attaching the conduit, a drill press for hardware mounting points, and a band saw for cutting out the aluminum framing.

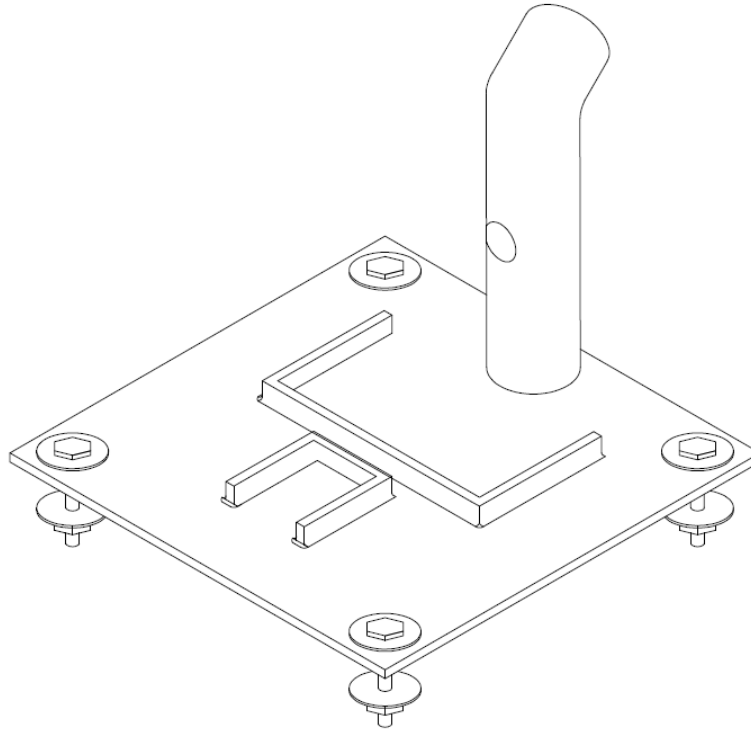

Upon procurement of all of the components, work can be started on assembling the base frame. This will begin with the 2' x 2' 6061 Aluminum plate. Any potential sharp edges will be rounded off to ensure safe operation when applied to park location. Following this, assemble the base frame in accordance with the mechanical drawings below. See included drawing PDF documents for the high quality renderings. Lastly, drill a 0.5" radius hole 2" from each of the four corners for the hardware mounts.

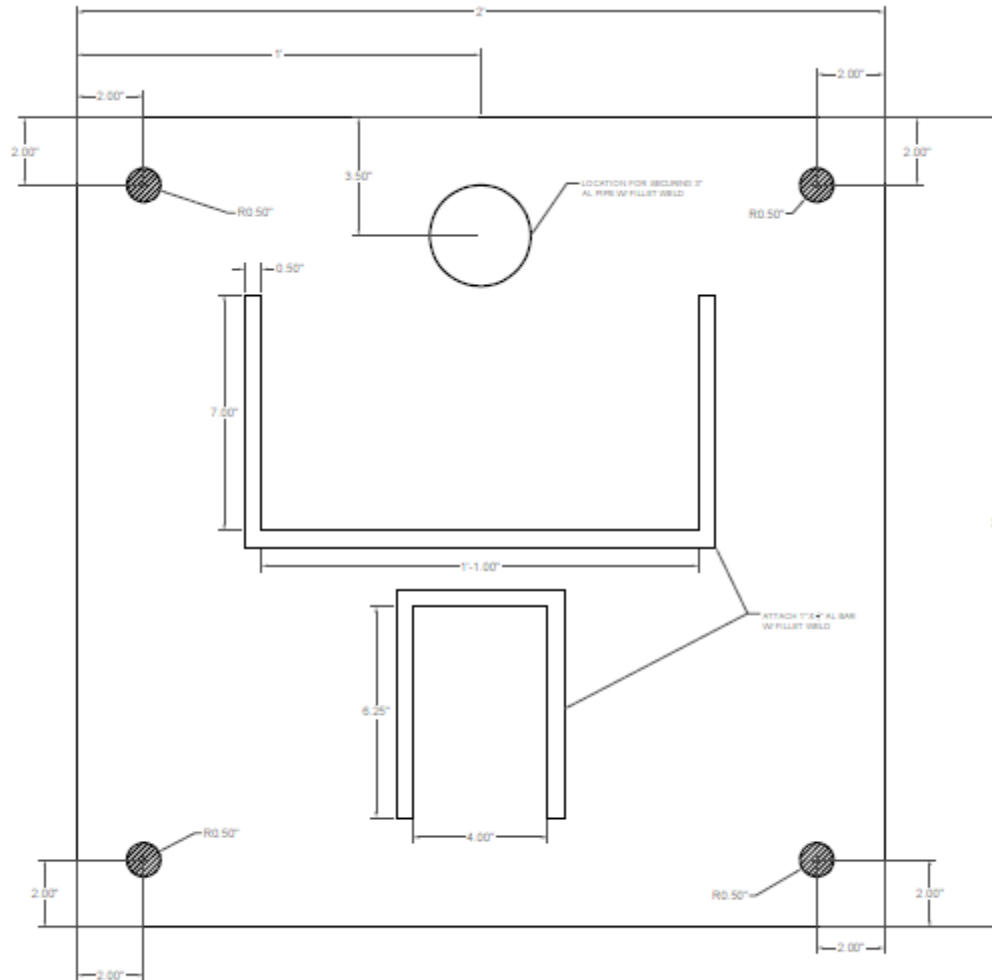

To construct the component framing, use a bandsaw to slice the 0.5" aluminum bar into 1" wide pieces, and then cut to the specified length in the layout above. Following cutting, round off all edges again for safety. Attach these using fillet welds.

Cut the conduit to 24" length, and bend 60° at 4" from the top. This will ensure that once mounted, the panel will have a tilt at 30°. Drill a 1" radius hole approximately 8" from the base. This will facilitate the entry and exit for the panel wiring from the charge controller to the battery.

## Prototype: Panel Mount

This section will pertain to the construction of the crossmember used to hold the panel and charge controller, as shown below:

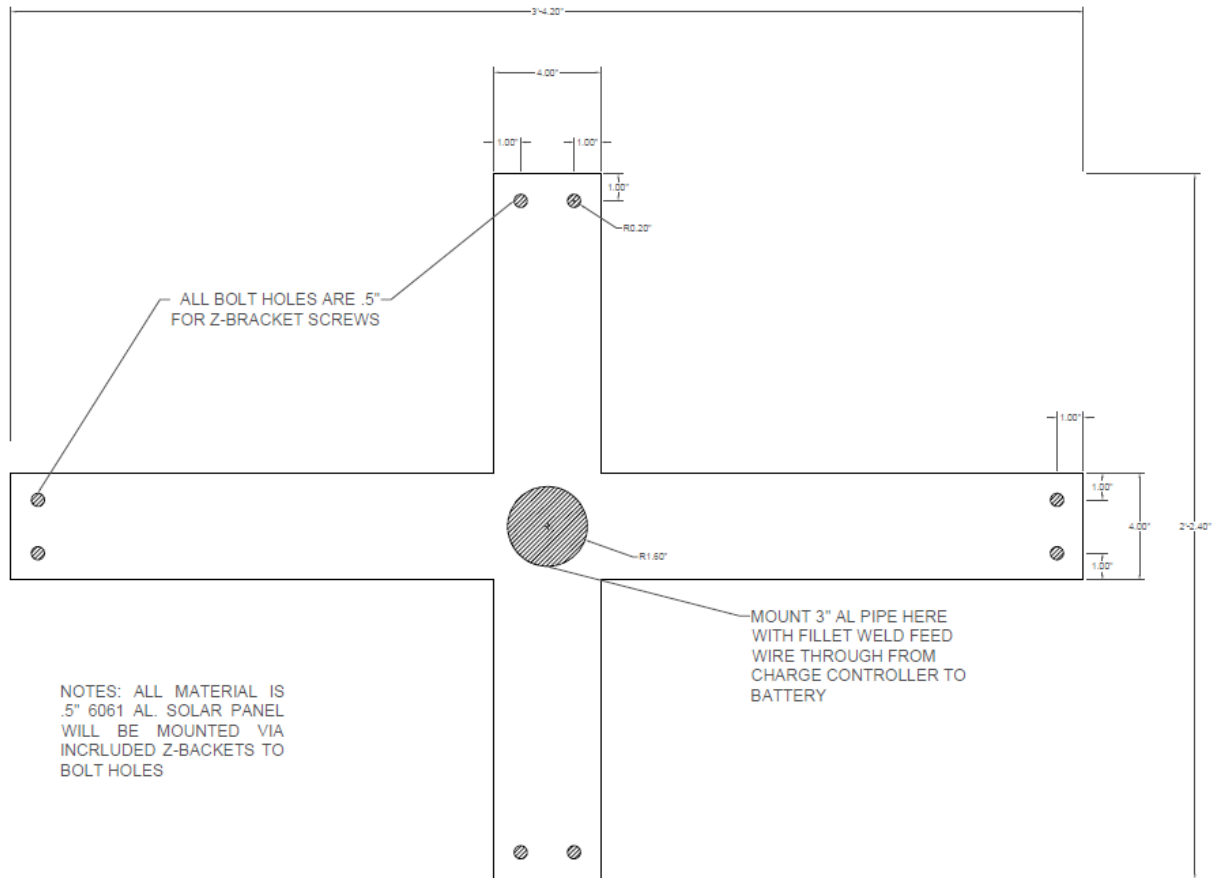

Construct the crossmember using 4" wide slices of 0.5" Aluminum bars at 26.4" and two at 18.1". Attach together using Fillet Weld such that the dimensions in the mechanical drawing are met. Drill a 1.5" radius (3" diameter) hole into the center. This will be the location to mount the conduit to, and will be the entryway for the wiring coming from the charge controller to the battery. Round off all edges to ensure safe operation.

For the screw holes, note that these are designed using Z-Bracket models found in the kit. However, these are possible to have changed in the design itself. This will likely be a point of modification going forward due to the Solar Kit changing its specifications.

Following completion here, mount the crossmember to the bent conduit and the base of the conduit to the base frame via fillet weld.

## Prototype: Final Assembly

The wiring for the Solar Kit is shown below in the included wiring diagram, derived from its operation manual. Note that the clips in which to mount to the battery will instead use screw terminals with battery covers. This was not included in the initial Bill of Materials, but is a potential safety modification going forward.

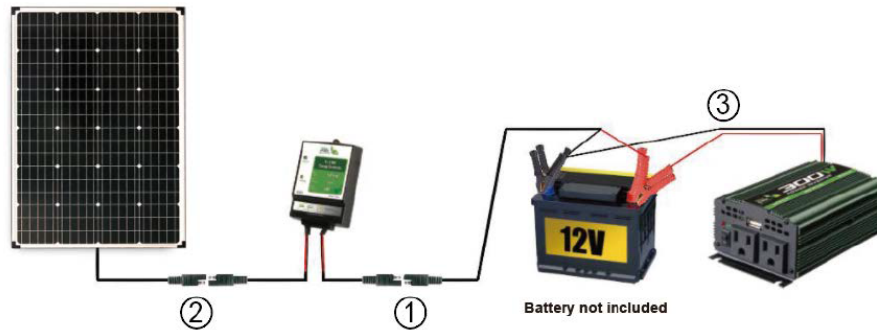

**Step1** Connect the charge controller to battery with SAE-battery clamp cable, Parallel connections = Positive to Positive and Negative to Negative

**Step2** Connect solar panels to charge controller

**Step3** Connect the 300 Watt power inverter to battery by "bare end - battery clamp" cable which included as the inverter accessories.

Place the battery in the area closest to the conduit; it should fit and have terminals pointed outward (away from the conduit). The converter will be placed at the front, with outlets pointed outward. Wire it according to that shown above. Any particulars in reference to the components can be found in the Operation Manual of the Solar Kit, which is included with the kit.

Once all is fixed into place and wired accordingly, the station can then be mounted onto a typical wooden picnic table using the Hex Bolts. The Final Assembly ought to resemble the Design below:

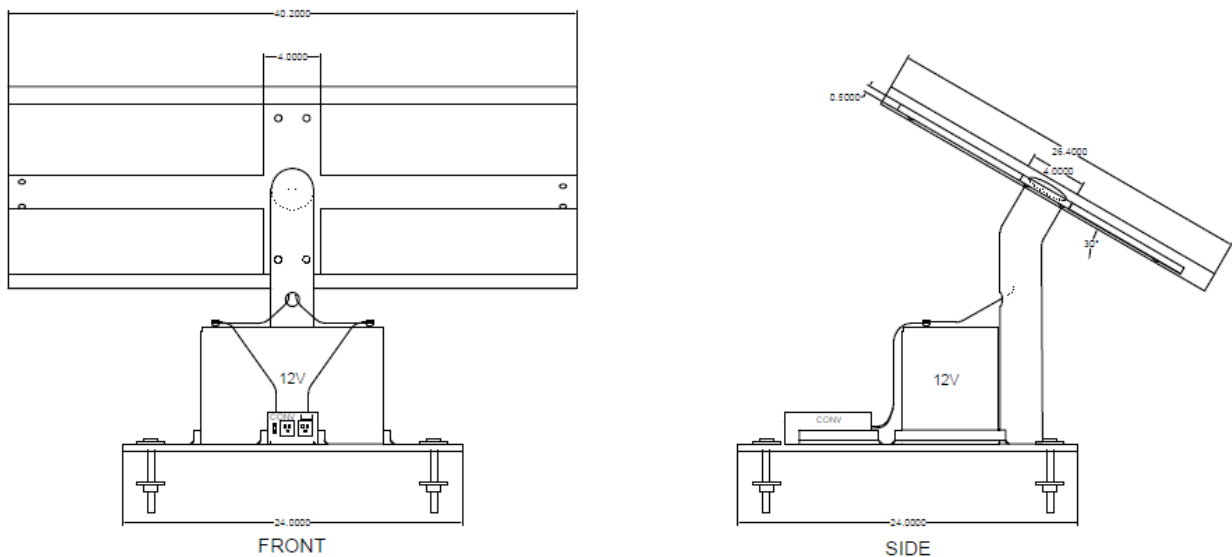

### Prototype: Orientation and Location

Orient the Charging Station to the south, ideally in a location with high sunlight penetration. After noting locations, the likely candidates for placement of the prototype charging station, as well as the Enerfusion Charging Station were added below on an Overhead Map shown below; with our locations noted by stars. We decided the marked stars would be the most ideal for social interaction.



## Vendor Product Implementation

The two main vendors we considered for work in the Park were BigBelly and Enerfusion. Both were proven to be easy to work with, helpful in data acquisition, and had useful products that would exceptionally benefit Woodville Park going forward.

In regard to the implementation of these products, the majority will be contacting the vendors and their representatives. For Big Belly, they will do all of the construction, maintenance, and will coordinate the connectivity. Enerfusion will require assembly of their charging station product, after being shipped. The Assembly instruction will be included in the shipment.

The Information for contacting these vendors are shown in the tables below.

<b>Enerfusion Inc: Joe Kobus, President</b>	
Work Phone:	(844) 876-9378
Mobile Phone	(517) 525-0368
Email:	<a href="mailto:joe@enerfusioninc.com">joe@enerfusioninc.com</a>

<b>Big Belly: Mike Phillips, Regional Sales Manager</b>	
Phone:	(978) 460-1977
Fax:	(781) 444-5651
Email:	<a href="mailto:mphillips@bigbelly.com">mphillips@bigbelly.com</a>

## Funding Sources

Most grant funding was not in its application stages for those with the highest possibility of usership. However, after discussing with the Florida Department of Agriculture and Consumer Services (FDACS), we found that there were grants that could potentially be helpful for funding these projects. We have listed them below as well as the links to their respective information webpages:

- Florida Small Community Energy Efficient Lighting Grant Program:
  - <https://www.fdacs.gov/Energy/Energy-Programs/Florida-Small-Community-Energy-Efficient-Lighting-Grant-Program>
- Florida Counties Low-Income Residential Energy Efficient Grant Program:
  - <https://www.fdacs.gov/Energy/Energy-Programs/Florida-Counties-Low-Income-Residential-Energy-Efficient-Grant-Program>
- Florida Renewable Energy Tax Incentives:
  - <https://www.fdacs.gov/Energy/Energy-Programs/Florida-Renewable-Energy-Tax-Incentives>

Additionally, we found a great deal of usage in the DSIRE database (<https://www.dsireusa.org/>) which lists all possible grants and funding sources. We also are including the link to the City of Tallahassee's Net Metering information, with the knowledge that this could reap the greatest economic benefits from renewable implementation, it should be considered in the future:

<https://www.talgov.com/you/you-products-home-solar-net-metering.aspx>