

Senior Design Project
T307
25 September 2020
Functional Decomposition

Table of Contents

Table of Contents	2
SECTION I: Brief Introduction.....	3
1.1: Explanation of Results.....	3
1.1.1: Functional Decomposition Introduction.....	3
1.1.2: Data Generation Discussion.....	3
1.1.3: Graphics Introduction	3
1.1.4: Functional Decomposition Discussion.....	4
1.1.5: Function Relationships	4
SECTION II	5
Figure I: Function Tree.....	5
SECTION III: Decomposition Levels.....	6
Figure II: Level 0	6
Figure III: Level 1.....	7
SECTION IV: Modules and Description of Functional Behavior.....	8
Table I: Level 0	8
Table II: Level 1.....	8
Table II.I: Level 1	9
Table II.II: Level 1.....	9
Table II.III: Level 1	10
Table II.IV: Level 1	10
SECTION V: Summary	11
5.1: Connection to Systems.....	11
5.2: Smart Integration.....	11
5.3: Action and Outcome.....	11
5.4: Function Resolution.....	12

SECTION I: Brief Introduction

1.1: Explanation of Results

1.1.1: Functional Decomposition Introduction

This document breaks down the functions that the prototype will perform, as driven by the needs and requirements derived from the customer (Dr. William Brey), and the insight from the sponsor (Paul Holcomb). The team was tasked to assess and discuss the functions the prototype must perform. In *Section II*, the function tree explains how the prototype will perform. In *Section III* the decomposition of the prototype is broken down into its appropriate levels. *Section IV* contains each individual module the prototype will contain, as well as its function and purpose within the system. Finally, *Section V* describes how the functions connect, act, integrated, and the overall function resolution.

1.1.2: Data Generation Discussion

For the data generation guidelines, there are several key points that are crucial for outputting the sought signal to the display. The signal will be coming in from a bidirectional coupler that is connected to the Radio Frequency (RF) power source and the pulse source “Figure III”. Once the signal is sent out from the pulse source, there are four important aspects that need to have fixed constants for the specified signal; the dynamic range, frequency range, sampling rate, and the trigger. The trigger is activated from the pulse source, which in return, tells the Software Defined Radio (SDR) to map the output signal from the RF power amplifier. The sampling rate relates to how long the pulse actually lasts and the number of samples needed per unit of time, in this case, at least 11MSPs. The dynamic range relates to the resolution on the display, for this project it needs to be at least 8-bits. Finally, the frequency range needs to be able to map the signal for high frequency tuning, between 600 MHz to 800 MHz.

1.1.3: Graphics Introduction

Below are several block diagrams and fundamental properties for the project. The Function Tree “Figure I” is a clean layout of the basic principles that the project has to execute or accomplish. Level 0 “Figure II” deals with the most basic block diagram of the prototype with its inputs and outputs specified. Level 1 “Figure III” is the whole schematic on which the tuning scope will be based off. It shows where the pulsed signal will be coming from, how much power will be directed into the system, where the scope will be connected, and the final output of the display.

1.1.4: Functional Decomposition Discussion

The functional decomposition information was based on the schematic in Dr. Brey's Keysight Oscilloscope proposal. Relevant details were gathered through meetings with our customer, Dr Brey, and Keysight (Sponsor) engineer Paul Holcomb. From those meetings it was clear that an SDR will work in an oscilloscope fashion. This means that the input RF pulses from the pulse generator and the probe must be analyzed as they would have been in an oscilloscope. In addition, the FD was gathered via meetings with Dr. Arora (Advisor), in which concepts of Q factor, trigger implementation and RF pulse display were discussed. The rest of the FD construction was accompanied by the whole team effort in researching the operation of SDRs and their intersystem capabilities and connectivity.

1.1.5: Function Relationships

The upper level function of the prototype is to modulate and analyze RF pulses by continuous sampling of the input RF signals. This function relates to the lower functions of the connected computer monitor to display the input RF power in and power out signals. Also, for the correct display function to be working appropriately, there is a need to introduce a trigger block. The function of this trigger block is to produce a trigger signal to synchronize the SDR timing analysis with the input RF pulse trains. The function of SDR to convert and analyze analog input RF signals depends on the proper operation of the attenuator function to reduce the power of the incoming RF pulse train from the bidirectional coupler.

SECTION II

Figure I: Function Tree

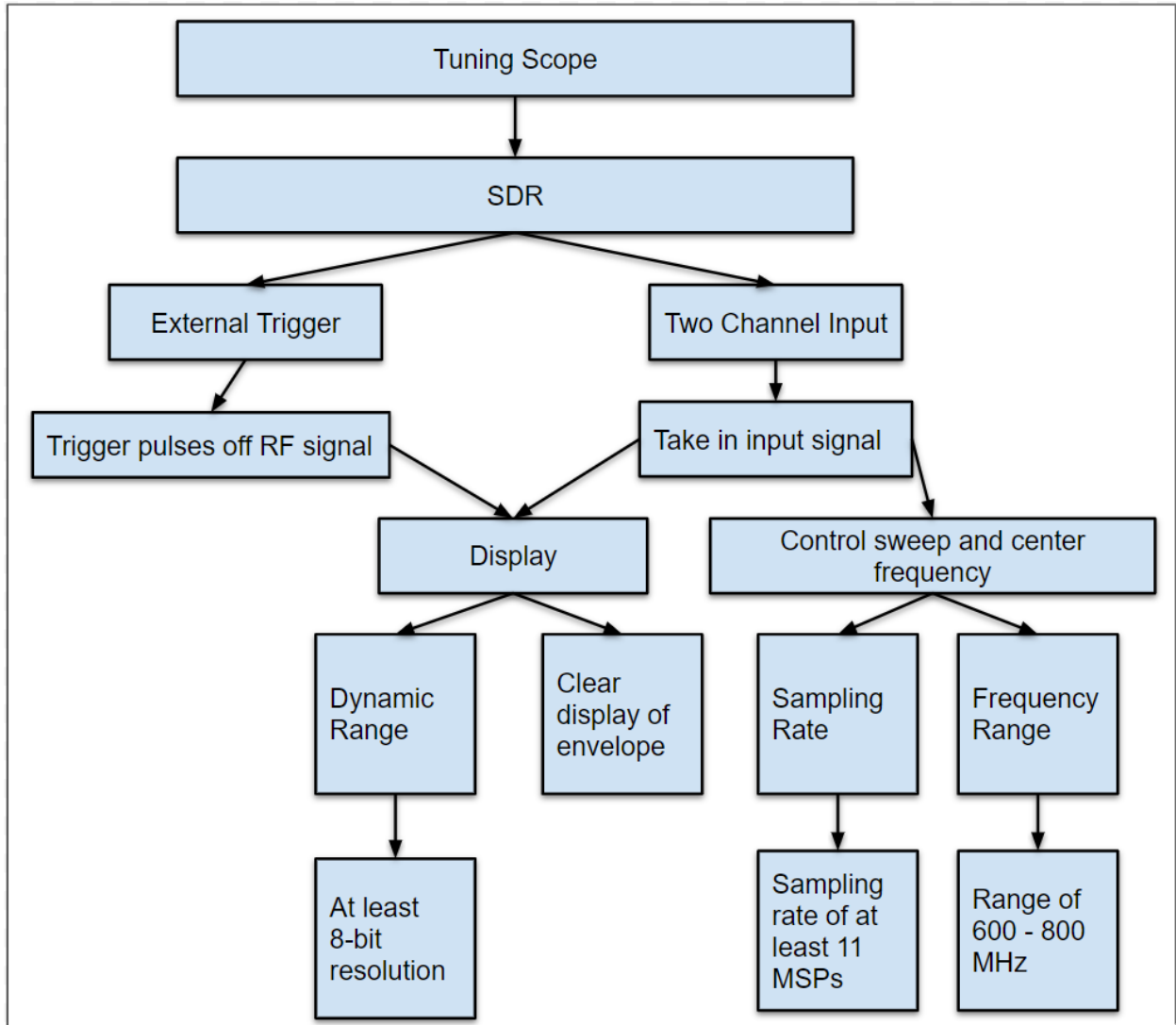

Figure 1: Function Tree parameters contained in this figure

SECTION III: Decomposition Levels

Figure II: Level 0

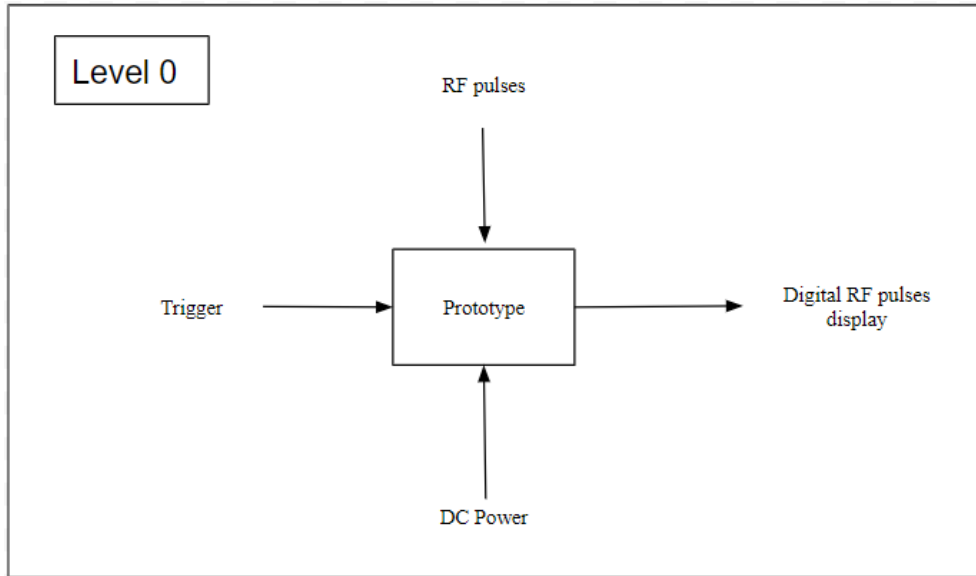

Figure 2: Level 0 Function Block Diagram

Figure III: Level 1

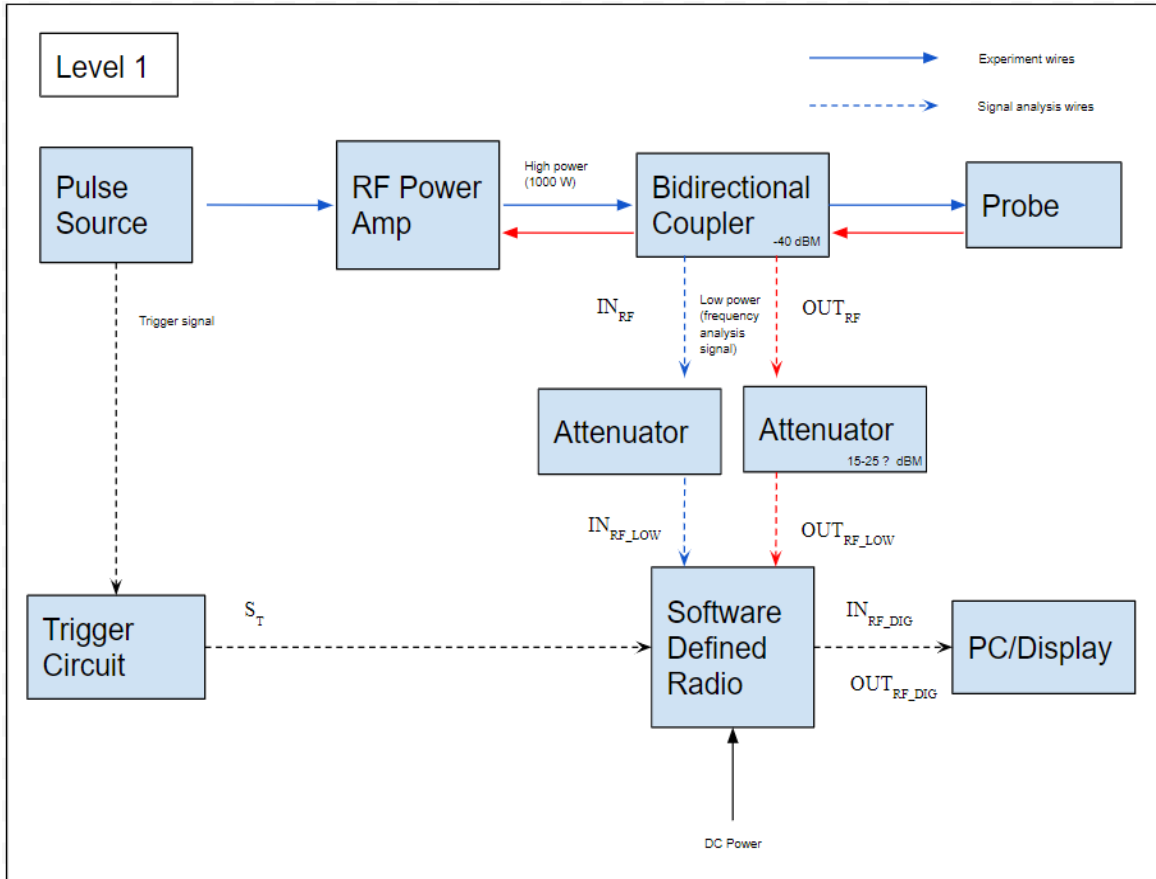

Figure 3: Level 1 Function Block Diagram

SECTION IV: Modules and Description of Functional Behavior

Table I: Level 0

<i>Module</i>	Prototype
<i>Inputs</i>	<ul style="list-style-type: none"> - RF pulse - Trigger - DC Power: DC input 4.5-5.5 V
<i>Outputs</i>	<ul style="list-style-type: none"> - Digital RF pulse display
<i>Functionality</i>	Modulates and analyzes RF pulses by continuous sampling. Sends recorded data to display after receipt of a trigger signal. Operates on 600 MHz to 800 MHz frequencies

Table 2: Level 0 parameters contained in this table (Prototype)

Table II: Level 1

<i>Module</i>	Trigger Circuit
<i>Inputs</i>	<ul style="list-style-type: none"> - Power source TTL trigger signal 50 Ohm wire
<i>Outputs</i>	<ul style="list-style-type: none"> - ST: Trigger signal in a form accepted by SDR
<i>Functionality</i>	Produces the trigger signal to be sent to SDR based on the TTL signal coming from Power Source

Table 2: Level 1 parameters contained in this table (Trigger Circuit)

Table II.I: Level 1

<i>Module</i>	Attenuator_1
<i>Inputs</i>	- INRF: RF signal coming from the Pulse Source input to the probe extracted from Bidirectional Coupler
<i>Outputs</i>	- OUTRF_LOW: RF signal with lower power to be accepted by SDR
<i>Functionality</i>	Reduces the power of the incoming RF signal for further analysis

Table 2.1: Level 1 parameters contained in this table (Attenuator_1)

Table II.II: Level 1

<i>Module</i>	Attenuator_2
<i>Inputs</i>	- OUTRF: RF signal coming from the probe power signal extracted from Bidirectional Coupler
<i>Outputs</i>	- OUTRF_LOW: RF signal with lower power to be accepted by SDR
<i>Functionality</i>	Reduces the power of the incoming RF signal for further analysis

Table 2.2: Level 1 parameters contained in this table (Attenuator_2)

Table II.III: Level 1

<i>Module</i>	Software Defined Radio (SDR) Device
<i>Inputs</i>	<ul style="list-style-type: none"> - ST: trigger signal to synchronize RF pulse recording with Power Source output - INRF_LOW: - OUTRF_LOW:
<i>Outputs</i>	<ul style="list-style-type: none"> - INRF_DIG: 8-bit binary representation of INRF_LOW - OUTRF_DIG: 8-bit binary representation of OUTRF_LOW
<i>Functionality</i>	Converts analog input of RF pulse train to binary digital output

Table 2.3: Level 1 parameters contained in this table (Trigger Circuit)

Table II.IV: Level 1

<i>Module</i>	PC/Display
<i>Inputs</i>	- SDIG_RF: recorded digital signal from SDR
<i>Outputs</i>	Plot of oscilloscope analysis onto a monitor using software tools
<i>Functionality</i>	Displays the RF pulses in a format of oscilloscope plot

Table 2.4: Level 1 parameters contained in this table (PC/Display)

SECTION V: Summary

5.1: Connection to Systems

The system under construction involves a prototype with a major function of analyzing analog input signals and outputting analyzed data in a digitized form. This major function is closely dependent on the function of a trigger circuit. The priority of proper operation of the trigger circuit is the highest. In the case, when a proper timing synchronization has been achieved by the trigger circuit and the SDR, the latter is able to perform correct RF pulse train analysis and output it to the computer display. A subsystem of the prototype - trigger system is the SDR USB connection with a computer. The function of a monitor to display the plot of an analyzed signal is dependent on the sampling function of SDR and inner SDR circuitry to output 8-bit resolution data to a computer. Therefore, the last two functions are of higher priority than the display function, which is predefined by a software of our choice. Therefore, an impact of this priority on project objectives is to focus on proper operation of the SDR ADC and the inner circuits to satisfy the operation of the function that outputs a digital signal to the computer. In addition, SDR function to analyze an analog signal is dependent on the attenuator function to decrease the power of the incoming RF pulse train. The attenuator function is then of a higher priority, which directs our project objective to purchasing appropriate attenuator modules for correct modulation of the power of incoming RF pulses.

5.2: Smart Integration

The attenuators work to further decrease the power of the signals output by the bidirectional coupler to prevent the SDR from being damaged. The first is for the incoming power from the source; the second for the incoming power reflecting from the probe. The trigger circuit uses the pulse source to assist the SDR with synchronizing the data desired by the user. Without this trigger, the user may receive undesired data.

5.3: Action and Outcome

The action that our prototype will provide is similar to that of an oscilloscope. The trigger circuit makes use of the pulse source to synchronize the SDR data with the time it is asked for by the user. The attenuators work to output a further reduced incoming power from the bidirectional coupler to prevent the SDR from getting damaged. The PC or display will work to tell the SDR when to retrieve the data, store the data sent from the SDR, and graphically display the desired RF pulse train data to the user.

5.4: Function Resolution

The functions performed by the prototype are entailed in this document. The functions have been assessed and discussed. The prototype's performance has been outlined. The prototype has been decomposed. Each individual module's contents and purpose have been determined. Lastly, the function's relationships and integration for an overall solution have been described. The design for the functional decomposition was established and accomplished by first analyzing the problem at hand and the prototype schematic from a top-level analysis. In addition, this simplified version of analysis allowed for the development of "Figure 2" to be established as a very simplified version of the external inputs and outputs. Further, "zooming in" to this diagram, one can achieve a mid-level analysis to view more layers of complexity. This can be seen in "Figure 3". Overall, the prototype to be designed has to display incoming RF pulses on the computer monitor in oscilloscope fashion. It can be assumed that everything was resolved in the aforementioned sections and therefore this resolution marks the successful completion of the functional decomposition.

– END OF DOCUMENT –