

# Computer Controlled Aiming and Tagging System (C-CATS)

Senior Design Final Report – April 2012

*By*

Alan Delgado, Broderick Epperson, Devin Swanson, Parker Brunelle  
*Department of Mechanical Engineering*



*Project Sponsor*

Robert Orgusaar

Eglin Air Force Research Lab, Munitions Directorate



Department of Mechanical Engineering  
FAMU-FSU College of Engineering  
2525 Pottsdamer St, Tallahassee, FL 32310

## **Table of Contents**

<b>List of Figures</b>	<b>ii</b>
<b>List of Tables</b>	<b>iv</b>
<b>Abstract</b>	<b>1</b>
<b>Introduction</b>	<b>3</b>
<b>Needs Assessment</b>	<b>3</b>
<b>Problem Description</b>	<b>3</b>
<b>Functional Diagram</b>	<b>7</b>
<b>Quality Function Deployment</b>	<b>7</b>
<b>Project Plan</b>	<b>8</b>
<b>Concept Generation</b>	<b>9</b>
<b>Final Concept – <i>Computer Controlled Aiming and Tagging System (C-CATS)</i></b>	<b>16</b>
<b>Engineering Economics</b>	<b>23</b>
<b>Experimental Procedure</b>	<b>25</b>
<b>Results and Discussion</b>	<b>31</b>
<b>Environment, Health and Safety</b>	<b>40</b>
<b>Conclusion</b>	<b>41</b>
<b>Appendix</b>	<b>44</b>
<b>Engineering Drawings</b>	<b>50</b>
<b>References</b>	<b>85</b>
<b>Biographical Sketch</b>	<b>86</b>

## List of Figures

Figure 1: Dynamic Testing Rig Setup	2
Figure 2: Early Component Mock Up	4
Figure 3: Functional Diagram	7
Figure 4: Gantt Chart	9
Figure 5: Concept 1 CAD Drawings	10
Figure 6: Concept 2 CAD Drawings	12
Figure 7: Optimized Concept 3	15
Figure 8: Final Concept	16
Figure 9: Final Prototype	16
Figure 10: Thrust Bearing to Turntable Design Change	17
Figure 11: Support Cross Braces and Turntable View	17
Figure 12: Gun Mounting Bracket	18
Figure 13: Motor Controller Flow Chart	21
Figure 14: Hammerhead Barrels and Components	26
Figure 15: Target Setup	26
Figure 16: Gun Stabilizing System	27
Figure 17: Gun Range Test Setup	28
Figure 18: Latency Test Setup	30
Figure 19: Total Shot Dispersion	32
Figure 20: Stock Barrel Rap4 G.O.L.F. Paint Test Data	34
Figure 21: 14-inch Hammerhead Barrel Rap4 G.O.L.F. Paint Test Data	34
Figure 22: Stock Barrel Evil Paint Gauge 0.686 Test Data	36
Figure 23: 14-inch Hammerhead Barrel Evil Paint gauge 0.683 Test Data	37
Figure 24: 14-inch Hammerhead Barrel Evil Paint gauge 0.690 Test Data	37
Figure 25: 16-inch Hammerhead Barrel Evil Paint gauge 0.683 Test Data	39
Figure 26: 16-inch Hammerhead Barrel Evil Paint gauge 0.690 Test Data	39
Figure 27: 16-inch Hammerhead Barrel Rap4 G.O.L.F. Paint Test Data	44
Figure 28: Stock Barrel Evil Paint gauge 0.679 Test Data	44
Figure 29: Stock Barrel Evil Paint gauge 0.683 Test Data	45
Figure 30: 14-inch Hammerhead Barrel Evil Paint gauge 0.679 Test Data	45

Figure 31: 14-inch Hammerhead Barrel Evil Paint gauge 0.686 Test Data	46
Figure 32: 14-inch Hammerhead Barrel Evil Paint gauge 0.688 Test Data	46
Figure 33: 16-inch Hammerhead Barrel Evil Paint gauge 0.679 Test Data	47
Figure 34: 16-inch Hammerhead Barrel Evil Paint gauge 0.686 Test Data	47
Figure 35: 16-inch Hammerhead Barrel Evil Paint gauge 0.688 Test Data	48

## List of Tables

Table 1: High Level Specifications	6
Table 2: Second Semester Project Plan	8
Table 3: Concept 1 Properties	10
Table 4: Concept 2 Properties	13
Table 5: Concept Decision Matrix	14
Table 6: Concept 3 Properties	15
Table 7: Budget Breakdown	24
Table 8: Hammerhead Barrel and Components	26
Table 9: Example Accuracy Data (Stock Barrel Evil Paint Data Shown)	49
Table 10: Bill of Materials	50

## Abstract

The Air Force Research Lab at Eglin is researching the accuracy and reliability of their fuze sensors. These sensors are used in Eglin's missile guidance systems to locate and lock on to possible targets. The munitions directorate needs a system to test the ability, accuracy and launch algorithms of the fuze sensor systems.

This project deals with creating a Computer Controlled Aiming and Tagging System, or C-CATS, which will test Eglin's fuze sensors. This system needs to be a non-destructive missile tagging system that will mark the center of the would-be impact and explosion on the target. Eventually, the C-CATS will be mounted to the front of the fuze sensors system and act as a scaled down warhead. The fuze sensors will constantly be updating the C-CATS with location coordinates, and when the sensors decide it is time, the C-CATS will be told to fire a marker, which is the "non-destructive" replacement of a full scale warhead. This will allow Eglin to see real time results for their future targeting system without damaging any components.

In order for Eglin to get the most accurate results for their tests, there are restraints that must be adhered to so the system will be up to standards. The most important constraint is that the marking system can traverse the entire forward hemisphere of the warhead to mimic the same ability of the real missile. It also must be able to turn the 360-degree azimuth in under 1 second. This is a feature designed for the future dynamic testing so the C-CATS program would have enough time to locate a target and position the aiming system before impact. The resolution of the motors must also be less than 1 degree so the motion of the marker is as smooth as possible. Another restraint is that the system must be less than 50 pounds because the rigging system has a weight limit, so the system cannot exceed that limit or it cannot be tested. The last major constraint is the system will be controlled by user input and must be safe to fire and will not have any unwanted discharges.

After statically testing the accuracy of the gun system, it was determined that the most accurate setup is the Tippmann A-5 marker with the 14-inch Hammerhead barrel using the 0.683 gauge Evil paint. This setup was the most accurate and had the least amount of left to right dispersion, which was an issue with the rifled Hammerhead barrels. After summing all of the targets, its average center of impact was 0.82 inches left

of the intended target, compared to some combinations that were as far off as 4.00 inches. This allows for all of the necessary calibration to be in the y-axis direction, which was a more stable and consistent miss because it was due to gravity.

Although this system combination was the most accurate, it still only had a target hit rate of 75%. The reason for the lack of accuracy or consistency is that the gun system does not contain a true pressure regulator system. This causes inconsistent results for each test, with fairly unpredictable results since each shot is not being fired under the exact same conditions. A solution and recommendation for increasing the accuracy would be to buy an after market pressure regulator for the Tippmann A-5, or purchase a nicer marker system with an electronic pressure regulator system, which would be the most accurate.

This targeting system meets all the requirements and standards that were given by the sponsor at Eglin. The motors are Dynamixel RX-64 motors that have a built in controller that allows them to know their exact position at all times without having to mechanically calibrate. They also meet the necessary requirement of moving the system 360 degrees in less than one second. It also weighs less than fifty pounds, can be fired at different targets, and can move from one target to another fast and efficiently. It also has a safety key to ensure the system does not fire when it is not ready. The system meets all of these standards and is as fast and agile as possible within the allotted budget.

## Introduction

### Needs Assessment

As the advancement of image fuze sensors progress, a nondestructive method is needed to evaluate the performance of the fuzing sensors at the endgame of flight to ensure peak performance and reliability. This project will require the use of nondestructive test methods in order to evaluate the accuracy of the fuze burst point control algorithm during each simulated flight using static testing methods. In addition, the speed and accuracy of the tagging system should be compatible with continuous target updates as the fuze sensor closes on the target and refines the burst point decision.

### Problem Description

The Air Force Research Laboratory (AFRL) needs a method to evaluate performance of fuze sensors and algorithms in a dynamic field test environment. The fuze sensors are designed to image the forward hemisphere of a weapon's velocity vector for the last one hundred meters of flight, detect targets of interest, classify these targets and pick an aimpoint on the target. For proof-of-principle demonstrations, AFRL plans

to eventually use a dynamic cable test rig that will allow the fuze sensor to fly a realistic trajectory toward the ground at scaled velocities. Figure 1 shows the testing rig with the height and angle used during testing.

In the past, cameras and

sensors have been used to

pin point the accuracy and direction of the fuze sensors during each cable run. This is an accurate method, but calls for hours of post-processing, from downloading the data collected, to analyzing it to determine whether or not it was a good run. If it was a bad test, or tests, then the whole process must start over, starting at setting back up the cable

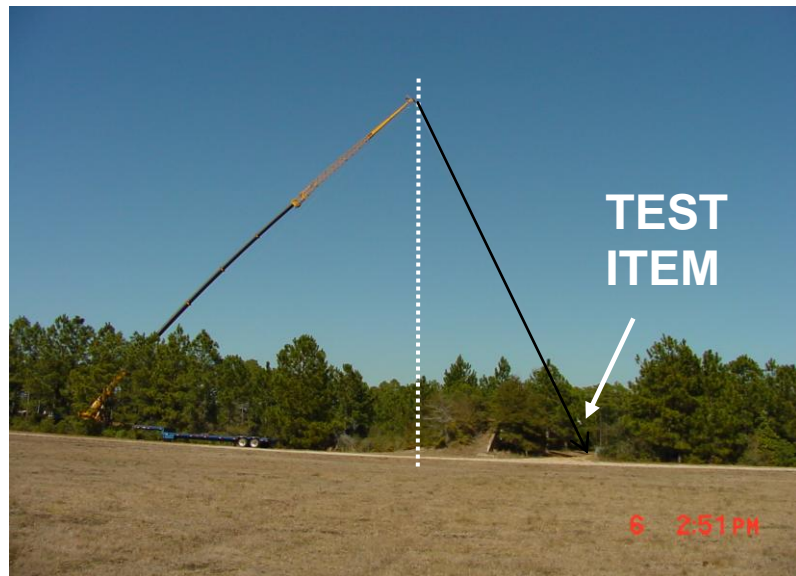

Figure 1: Dynamic Testing Rig Setup



system, and then running multiple tests, and finally back to more post-processing. So, the AFRL is looking for a reliable way to gather real time data feedback in the on field tests. This instant feedback will allow for immediate analysis on the accuracy and direction of their fuze sensors.

### Goal Statement

By the end of the senior design project, our goal is to have a fully functional, nondestructive marking device that will allow AFRL to test the accuracy and repeatability of their computer controlled aiming and tagging system. The product will have the capability of computer interfacing to allow even more testing capabilities for the Munitions Directorate. The final product will be lightweight enough to carry the necessary control systems and have some sort of marking system that will be able to range the entire forward hemisphere of the device. The product, fully functional, will be within the given safety standards and will be able to fire multiple marks with accuracy, have minimal latency and be able to repeat all tests.

### List of Objectives

The final objectives for the team is to design, fabricate, and demonstrate a computer controlled aiming and tagging system that can eventually be integrated with developmental active imaging fuze sensors for proof-of-principle demonstrations. For this prototype, targets of interest will be placed at respective realistic distances from the weapons trajectory to evaluate the effectiveness of the active imaging fuze sensors in a static data collection environment. The target objective for the system to be considered accurate in this testing environment is that the ballistic must hit within a one-degree circle of the intended target. A paintball gun like system is needed that can be aimed and fired by the fuze sensor during these initial static test simulations.

The prototype must also be able to receive a user defined set of coordinates, move the barrel to the target and accurately fire several paintballs to tag the target. The object of this test is to make sure the system can aim, shoot, and re-aim, and be pointing and shooting at the correct coordinates. For this test, once again the ballistic must hit within a one-degree target area, and also the motor aiming system must be sitting at the desired

output angle, which will be monitored through the control program. The objective is to have the error in the motors less than  $\pm 0.5^\circ$ , which would allow the ballistic to still hit within the one-degree accuracy circle down range. It must do this with a high level of precision and accuracy and at a defined speed.

The final objective is to minimize the system latency. Because this system will eventually be used in a dynamic testing scenario, the AFRL wants to know what the delay is between the users input command and the system output response. This is especially important for the firing algorithm, because if the fire command is entered and the system does not fire for another second, the ballistic could miss the target by a few meters, which would throw off all other data collection. Because the latency can be calibrated for, the objective is to time it and minimize the amount of time, but record it to

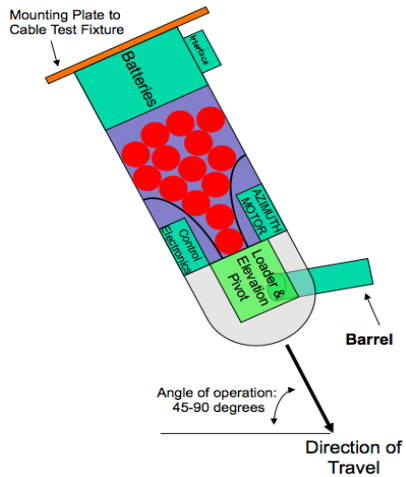

allow for necessary adjustments to be made when firing the system.

The customer provided us with a simple mock up of the general components that will be necessary to complete this project and our objectives. Figure 2 shows the drawing with the parts. Its to be noted that there are a couple of components present in this figure that will not be necessary in the final design due to the

fact that we are designing for a static test only. One is the mounting plate, which would be necessary to mount the system to the test rig that we will not be using, so it is not necessary. Also, it shows the angle of attack as  $45^\circ$  to  $90^\circ$  below the horizontal, which is not a necessary design parameter for the static testing. It should also be noted that since this mock up list was sent, the power source has been changed. Instead of batteries, which must be recharged frequently, we will be using standard wall plugs to power our system.

### Testing Environment

The Air Force Research Laboratory at Eglin will eventually be using the Computer Controlled Aiming and Tagging System to dynamically test their active fuze sensors. This system, as shown in Figure 1, will be run on an outside rigging system. This

means that all of the components will be exposed to outdoor elements such as wind and sun exposure. We have been told that no testing will occur during severe weather such as high winds or rain. This means that all of the components and final prototype will need to be tested outside in an open environment. All ballistic testing will be in an open field, allowing for the wind and other elements to affect the flight of the projectile, since it will not be flying in an ideal environment at Eglin. Also, the prototype will be tested outside to make sure all of the individual components are secure to the system and operate correctly.

### List of Constraints

After multiple conference calls with the sponsor, the customer needs and project goals and objectives were determined, which have been outlined in the problem description section. Table 1 shows the high level engineering specifications and project constraints that were agreed upon by the group and the sponsor that correspond with the customer needs.

**Table 1: High Level Specifications**

<b>Specification</b>	<b>Value</b>
<b>Budget</b>	\$2000
<b>Maximum Range</b>	25 m
<b>Azimuth Range</b>	360°
<b>Elevation Range</b>	90°
<b>Angular Velocity</b>	$\geq 360^\circ/\text{s}$
<b>Resolution</b>	$\leq 1^\circ/\text{s}$
<b>Maximum Weight</b>	50 lbs.
<b>Power Source</b>	Standard Wall Outlet
<b>Motors</b>	Servos
<b>Tagging System</b>	Paintballs

## Functional Diagram

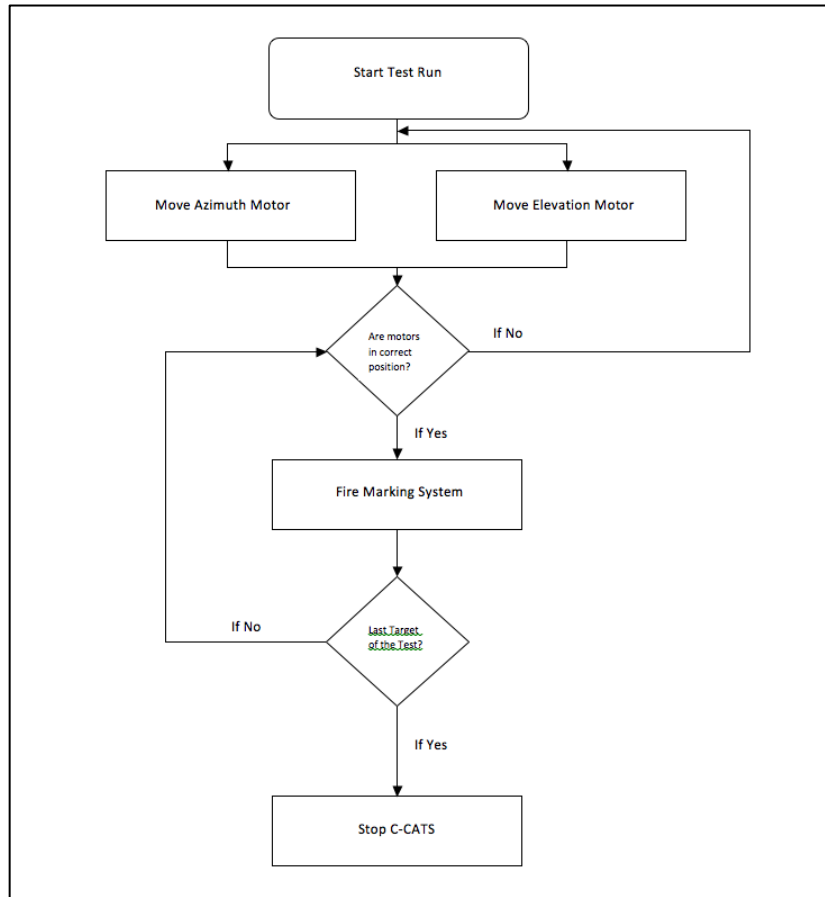

Figure 3: Functional Diagram

## Quality Function Deployment

		Engineering Specifications						
		Case must be lighter than 50 lbs.	Power System last longer than 6 hours	Slew rate less than 360 degree/sec	User input coordinates (deg)	Paintball Gun accurate to 25 m	Firing System fires within 2 sec of aiming	Slew Rate Resolution less than 1 degree
<b>Customer Needs</b>	Must be light weight	x	x			x		
	Locally Housed Components	x						
	Smooth Azimuth/Elevation Movement			x				x
	Easy to Use Power System		x					
	Computer Interfacing				x		x	
	Accurate			x		x		x
	Repeatable			x		x		
	Must be able to shoot and Re-aim			x				
	Non Destructive Marking Device					x		
	Must be safe to operate						x	

An x denotes that there is a relation between the customer need and the translation into an engineering specification.

## Project Plan

Table 2: Second Semester Project Plan

Computer Controlled Aiming and Tagging System			
Tasks	Start Date	Duration (Days)	End Date
Needs Assessment	20-Sep	15	4-Oct
Product Specification	5-Oct	9	13-Oct
Product Specification Review	11-Oct	3	13-Oct
Concept Generation and Selection	14-Oct	14	27-Oct
Concept Generation and Selection and Review	25-Oct	3	27-Oct
Interim Design	28-Oct	19	15-Nov
interim Design Review	13-Nov	3	15-Nov
Overall Assessment (Go/No Go)	16-Nov	7	22-Nov
Final Design Package	22-Nov	15	6-Dec
Finalize Bill of Materials	24-Nov	7	1-Dec
Order Materials	1-Dec	17	16-Dec
Receive Materials/Build Prototype	4-Jan	37	10-Feb
Conference Call with Robert Orgusaar	6-Jan	1	6-Jan
Project Plan Revision	9-Jan	1	9-Jan
Staff Meeting #1/Project Plan Due	10-Jan	3	12-Jan
Conference Call with Robert Orgusaar	28-Jan	1	28-Jan
Staff Meeting #2/Team Evaluations #3 Due	31-Jan	3	2-Feb
Conference Call with Robert Orgusaar	9-Feb	1	9-Feb
Testing/Rebuilding	10-Feb	35	16-Mar
Mid-Point Review Presentations Revision	9-Feb	5	13-Feb
Mid-Point Review Presentations	14-Feb	3	16-Feb
Conference Call with Robert Orgusaar	27-Feb	1	27-Feb
Staff Meeting #3/Team Evaluations #4 Due	28-Feb	3	1-Mar
Instructors Visit	13-Mar	3	15-Mar
Staff Meeting #4	20-Mar	3	22-Mar
Conference Call with Robert Orgusaar	23-Mar	1	23-Mar
Revision of All Finalized Material	23-Mar	11	2-Apr
Final Presentation/All Finalized Material Due	3-Apr	3	5-Apr
Open House	12-Apr	1	12-Apr

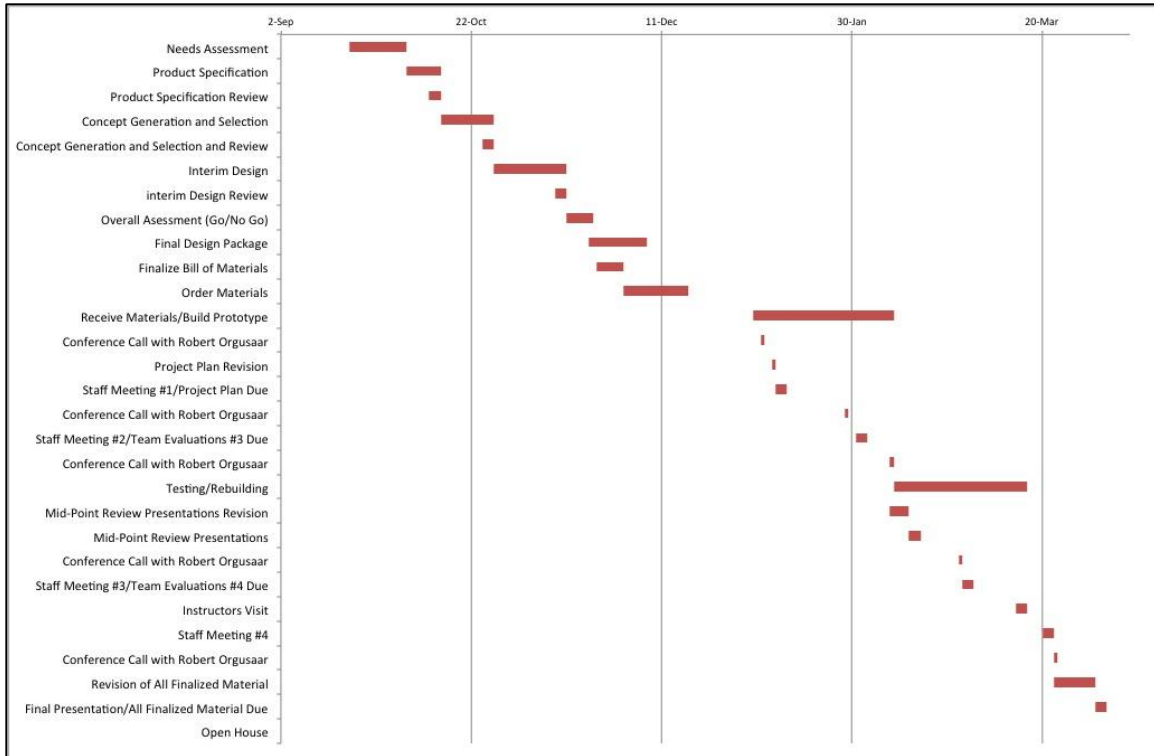
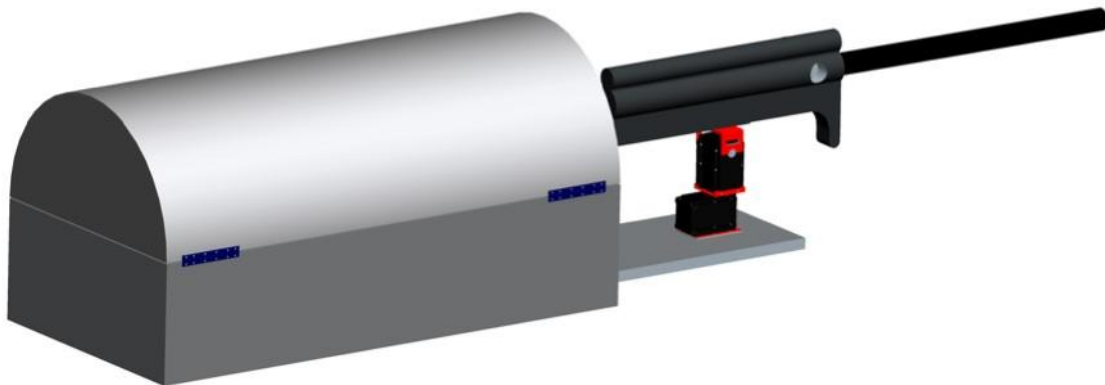
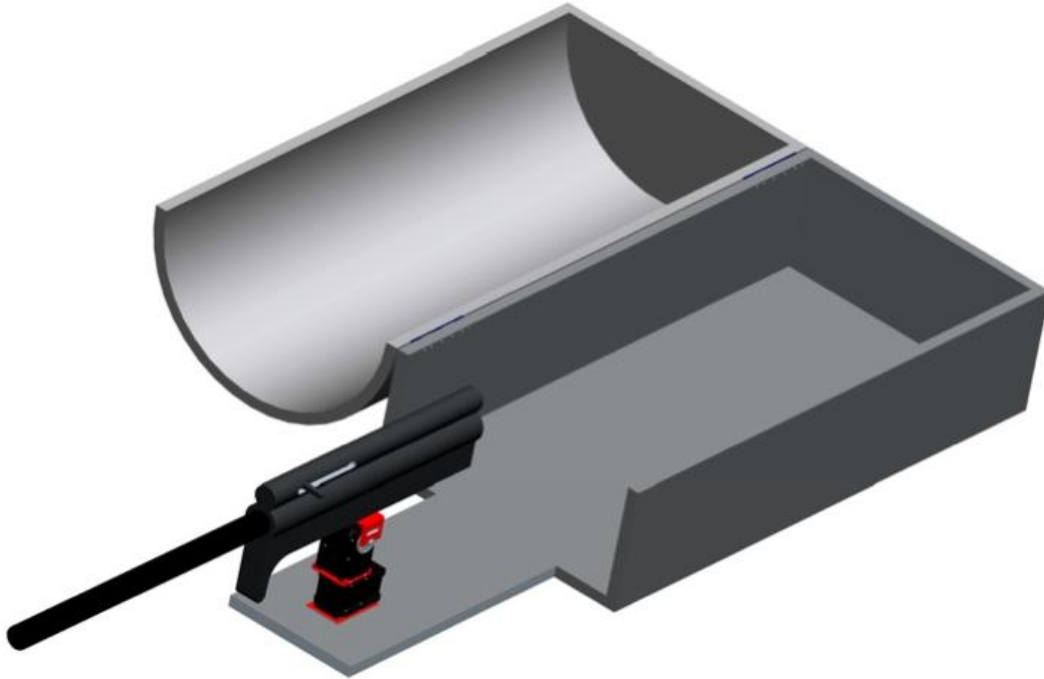

Figure 4: Gantt Chart

## Concept Generation

### Concept 1





**Figure 5: Concept 1 CAD Drawings**

Concept 1 is based on the idea of a compact, aerodynamic, stationary shell or housing, with the gun and both motors exposed and rotating on their own. Figure 5 shows a picture of the concept. None of the components are shown, but they will all be housed in the back “mailbox” shaped portion of shell. The top of the shell is hinged which would allow for easy access to the components if anything needed to be adjusted.

**Table 3: Concept 1 Properties**

<b>Concept 1 Properties:</b>	
<b>Housing</b>	Aluminum 2024/6061
<b>Elevation Torque Needed</b>	4.95 N*m
<b>Azimuth Torque Needed</b>	5.59 N*m
<b>System Weight</b>	49 lbs.

### Pros

The pros of this system is that the motors are sitting completely free out in the front of the assembly and is only supporting the weight of the gun. This is good for multiple reasons. For one, this allows a complete view of the forward hemisphere by the gun, with the ability to rotate in any direction without the possibility of any other

components getting in the way. The other reason this design is very good is that the motors are only supporting the weight of the gun, and the gun is mounted directly to them, so there are no arms that have to be rotated, which adds torque. This improves the performance of the motors and the life of the motors.

### Cons

There are some drawbacks to this type of concept. The con that is possibly the most glaring is that the system weighs almost fifty pounds, which is shown in Table 2. This gives no room for error when fabricating or assembling the system. Also, all of the components are locked and stationary in this design. This could cause possible bindings of wiring or hosing while the gun is moving. If anything were to lock up the air tube or the ball feeding hose, the system would be unusable. Another downside to this design is the platform the gun and motors sits on. There are not many ways to support this platform without adding more weight or size to the system, but without any support, there is no guarantee the platform will be steady enough in the long run. Also, the fabrication of this system would be difficult because the housing has a rounded top. This top would need to have very low error to fit the system, and easy access to a metal roller is tough to find.



## Concept 2

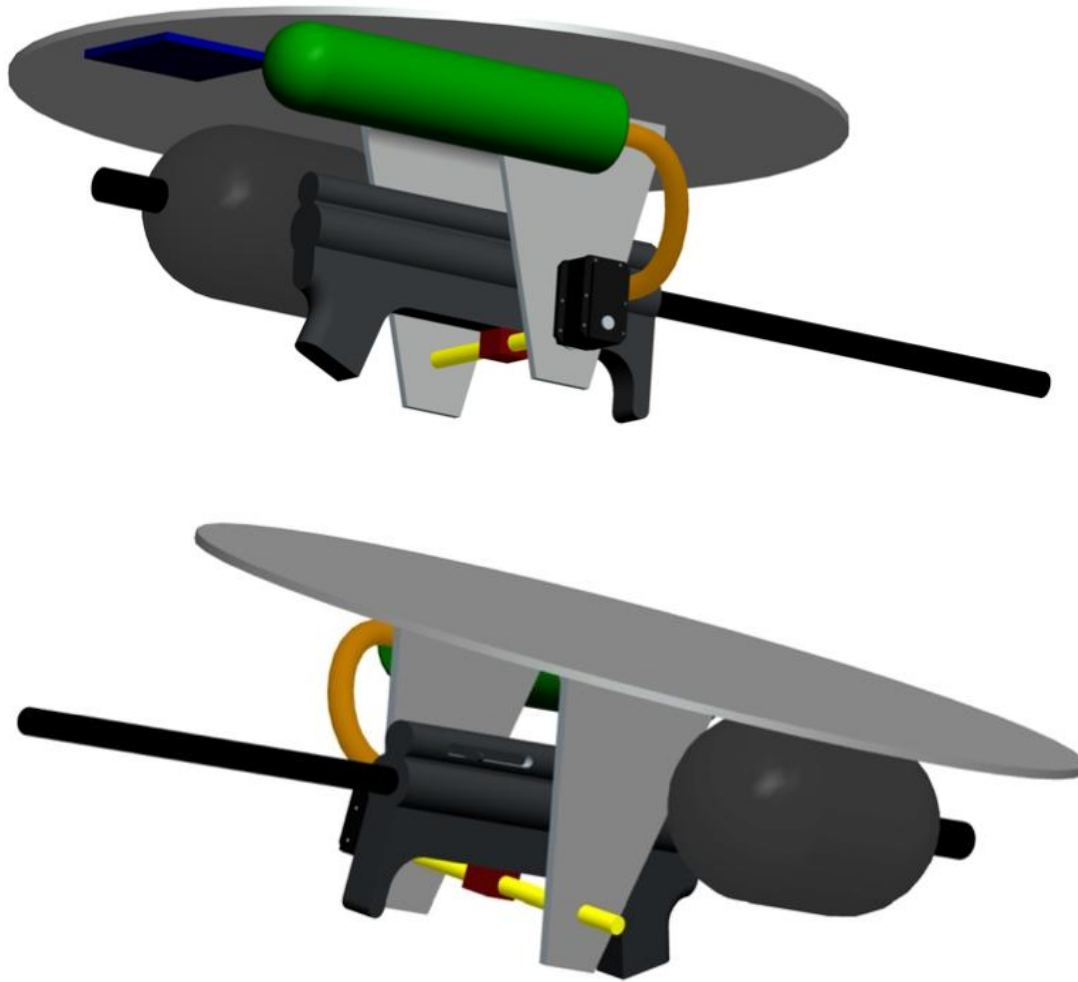

**Figure 6: Concept 2 CAD Drawings**

Concept 2 is based on a turret design similar to that on a B-25 Mitchell bomber. Its design is made up of a base plate that will be made of aluminum, either 2024 or 6061, due to the fact that it is light weight, but strong enough to hold the brackets where other components will be housed. Figure 6 shows this baseplate with the different components that will be mounted to it. Not shown is the motor that would be mounted to the baseplate and drive the azimuth direction of the system's motion. Concept 2 will then have an "A" shaped bracket that will hold the actual paintball gun and the elevation motor. The rigging mounts for this concept are not shown and would be placed on the large baseplate.

Table 4: Concept 2 Properties

Concept 2 Properties:	
Baseplate	Aluminum 2024/6061
Gun Bracket	Aluminum 2024/6061
Elevation Torque	4.95 N*m
Azimuth Torque	77.8 N*m
System Weight	21 lbs.

### Pros

The main pro to this concept is that every component is located on the baseplate, which is all driven by one motor. This allows the entire system to spin in a full circle without having to worry about any tying or binding of wiring or tubing. Also, since this system is upside down with the gun mounted on the bottom, this would allow for an easy transition from static testing to dynamic cable testing. This is because the gun would be facing a sharp downward angle on the dynamic testing rig, and this set up is already in that configuration. This is not a requirement, but would greatly help our sponsor in the future.

### Cons

This design does have some flaws though. Both motors on this design have major weak points. The elevation motor, the one shown in the picture that directly drives the gun, is strained because it is driving the gun with a rotating arm, and this arm increases the load the motor has to move by creating a moment arm. For the motor not seen that would have to drive the azimuth motion, as shown in Table 3, the torque required to move the whole plate is very large. A motor this large would not only cost too much, but also be much larger than the space or weight allows for. Also, with no bearing system, the total weight of the turret would be on the motor, burning out the motor very fast.

### Concept Decision Matrix

**Table 5: Concept Decision Matrix**

Specifications	Weight	Concepts			
		Concept 1		Concept 2	
		Rating	Score	Rating	Score
System Weight	30.0%	2	0.60	4	1.20
Elevation Torque	25.0%	4	1.00	4	1.00
Azimuth Torque	25.0%	4	1.00	1	0.25
Area for Components	20.0%	2	0.40	3	0.60
Total	100.0%		3.00		3.05

It is shown in Table 4 that both concepts score very similar criteria scores. This has led the group to believe it is possible to optimize the concepts with a third and final prototype.

### Concept 3

After looking at both concepts and the concept decision matrix, Concepts 1 and 2 are very close in terms of pros and cons. For example, Concept 1 is much better in terms of torque needed by each motor, but as far as the area needed to house the components and their wiring, Concept 2 is a much better idea. Because both concepts scored very close in the decision matrix, the team came to a conclusion to design a third concept with as many optimized components from the first two concepts as possible. Shown below in Figure 7 is the final optimized Concept 3.

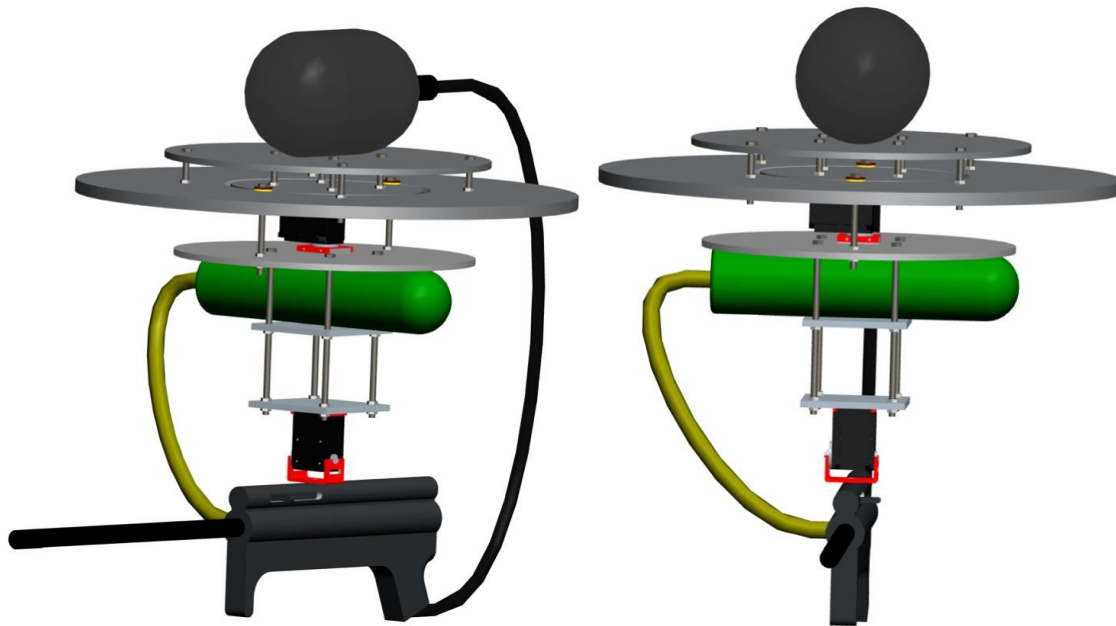

**Figure 7: Optimized Concept 3**

The main concept change that occurred was keeping an open, turret style setup like Concept 2, but repositioning the motors. Figure 7 shows that the azimuth motor is now in between the baseplate and gun, which reduces the amount of torque on that motor, which is shown in Table 5. This concept uses a thrust bearing system to take all the vertical weight off of the azimuth motor to minimize its load responsibility.

**Table 6: Concept 3 Properties**

<b>Concept 3 Properties:</b>	
<b>Baseplates</b>	Aluminum 6061
<b>Bridge Plate</b>	Aluminum 6061
<b>Elevation Torque</b>	4.95 N*m
<b>Azimuth Torque</b>	10.21 N*m
<b>System Weight</b>	30 lbs.

**Final Concept – Computer Controlled Aiming and Tagging System (C-CATS)**



**Figure 8: Final Concept**



**Figure 9: Final Prototype**

The final concept that was chosen is shown in Figure 8 and Figure 9. This design is relatively the same as Concept 3, however it features more optimization and a few new parts. The biggest change was going from using thrust bearings to control the azimuth motion to using a lubricated turntable shown in Figure 10 (Right). This feature was chosen because it creates less friction than the thrust bearings allowing smoother motion and less of a force required to turn. Also, using the turntable does not require the extra material that would have been needed to machine a bridge, which makes the design lighter and takes out the error in lining up the inside and outside plate for the bearings to spin on.

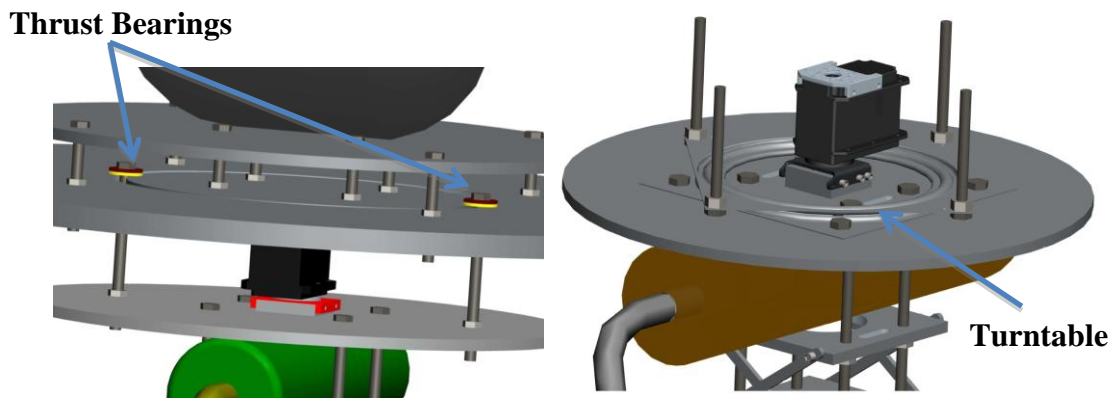

Figure 10: Thrust Bearing to Turntable Design Change

Apart from the turntable, other parts that were introduced were a pair of cross braces, shown in Figure 11, to add extra support to the lower structure, and another turntable on the top to mount the nitrogen bottle, shown in Figure 11. This top turntable will allow the bottle to rotate with the rest of the system, keeping as little tension on the air hose as possible.

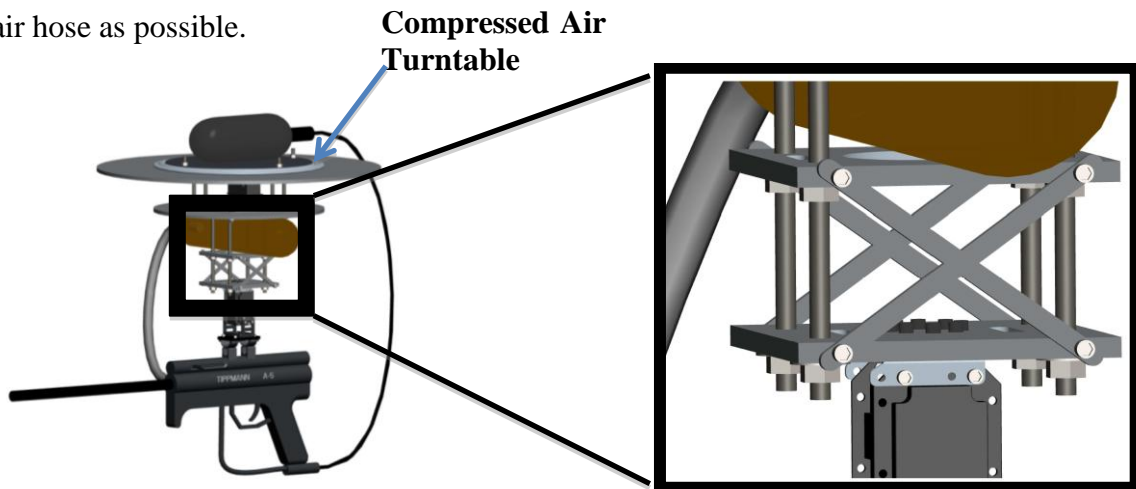

Figure 11: Support Cross Braces and Turntable View

The final addition to the Final Concept was a pair of scope mounts that allow the gun to mount to the elevation motor. The motor came with a metal bracket and an attachable plastic piece that is made specifically to allow for modifications so that aftermarket items can be attached to the motors. The scope mounts are regular rifle dovetail scope mounts that have a detachable upper ring. Figure 12 shows the how the mounts connect to the plastic plate by using the lower half of the mounts and the pre-tapped holes and bolts that the mounts came with.

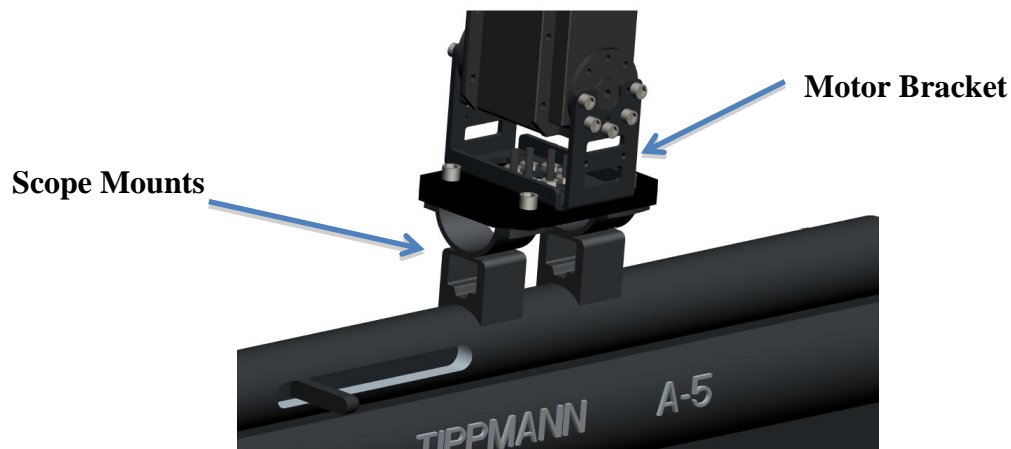

Figure 12: Gun Mounting Bracket

## Final Concept Components

### Frame Materials

The material for all of the large plate construction is Aluminum 6061. By utilizing *Mechanical Metallurgy* by G.E. Dieter, and comparing prices on McMaster-Carr, we determined that this would give us the amount of strength and durability we needed and the lightest weight all for the lowest cost. Since the primary usage of this system will be outdoors, we looked into some more expensive aluminum alloys that would be more weather resistant, but determined that 6061 would be sufficient because the system will only be used during good weather and should not be exposed to any rain or rust.

All of the nuts and bolts are made out of steel. The steel bolts provided the strongest and stiffest frame possible, and would reduce any kind of bending or twisting at the joints. Also, the steel bolts and aluminum frame will be in constant contact in adverse conditions for an extended amount of time, so we made sure that neither component was

made out of an exotic material that might corrode the other any faster than normal. Therefore, steel was chosen for the nuts and bolts since it has almost no effects on the material properties of the aluminum plates.

Another component that factored into the material selection process was the need to secure all the frame components in place. To make sure that none of the pieces come loose during operation, we plan on using Loctite Blue 242. This allows for all the nuts and bolts to be secured into place, but also lets them to be disassembled if necessary. This Loctite is only compatible with certain types of metal materials, including steel bolts, so this reinforced the decision to use the materials that were chosen.

### Motors and Controller

The controller used for controlling the servo motors and firing the marker in the system is an Arbotix Robocontroller. The controller has 32 I/O pins; two are used to control the firing mechanism by one sending a digital high to one Hall-Effect sensor, and the other sending a digital low to another Hall-Effect sensor located on the board of the electronic grip of the gun. The arbotix controller is mounted with a 16MHz AVR microcontroller (ATMEGA644p) allowing for quick data acquisition when PIV control is integrated in the future. The system will also be controlled wirelessly using a pair of XBee radios. One will be connected to a PC using a USB connection and the other will mount on a serial port dedicated to an XBee radio on the arbotix controller. The XBee radios allow for wireless communication to the controller from 100 meters. To use the servo motors chosen for the design, the RX-Bridge, which is a separate add-on, must be mounted to the arbotix controller. When the RX-Bridge is mounted onto the arbotix controller it allows for communication to the RX and EX servos described below.

The servo motors controlling the marker in the system were initially chosen to be two Dynamixel brand motors. These motors rely on communication between the main controller and a controller located inside of the servo motor. Instruction packets send data from the main controller to the motor, the motors then feedback a status packet to the main controller. This allows for PIV feedback control to be easily integrated into the system in future development. Two types of motors were considered for the design. One motor called EX-106+ has a holding torque of 84 kg/cm and the other RX-64 has a holding torque of 53 kg/cm. Both have a resolution of less than a degree and can rotate



360 degrees in approximately one second. These characteristics cover all of the necessary requirements to run the system; the torque meets the criteria, they allow for easy communication and constant position feedback and are also in the necessary price range.

The initial design was to incorporate an EX-106+ motor to control the pan and an RX-64 motor to control the tilt of our marker. But, after some design changes it was decided to remove the RX-64 motor and replace it with EX-106+ motors because the libraries being used are not compatible when daisy chaining two different motors. This is because the RX-64 servos have a 10-bit range, but the EX-106+ motors have a 12-bit range.

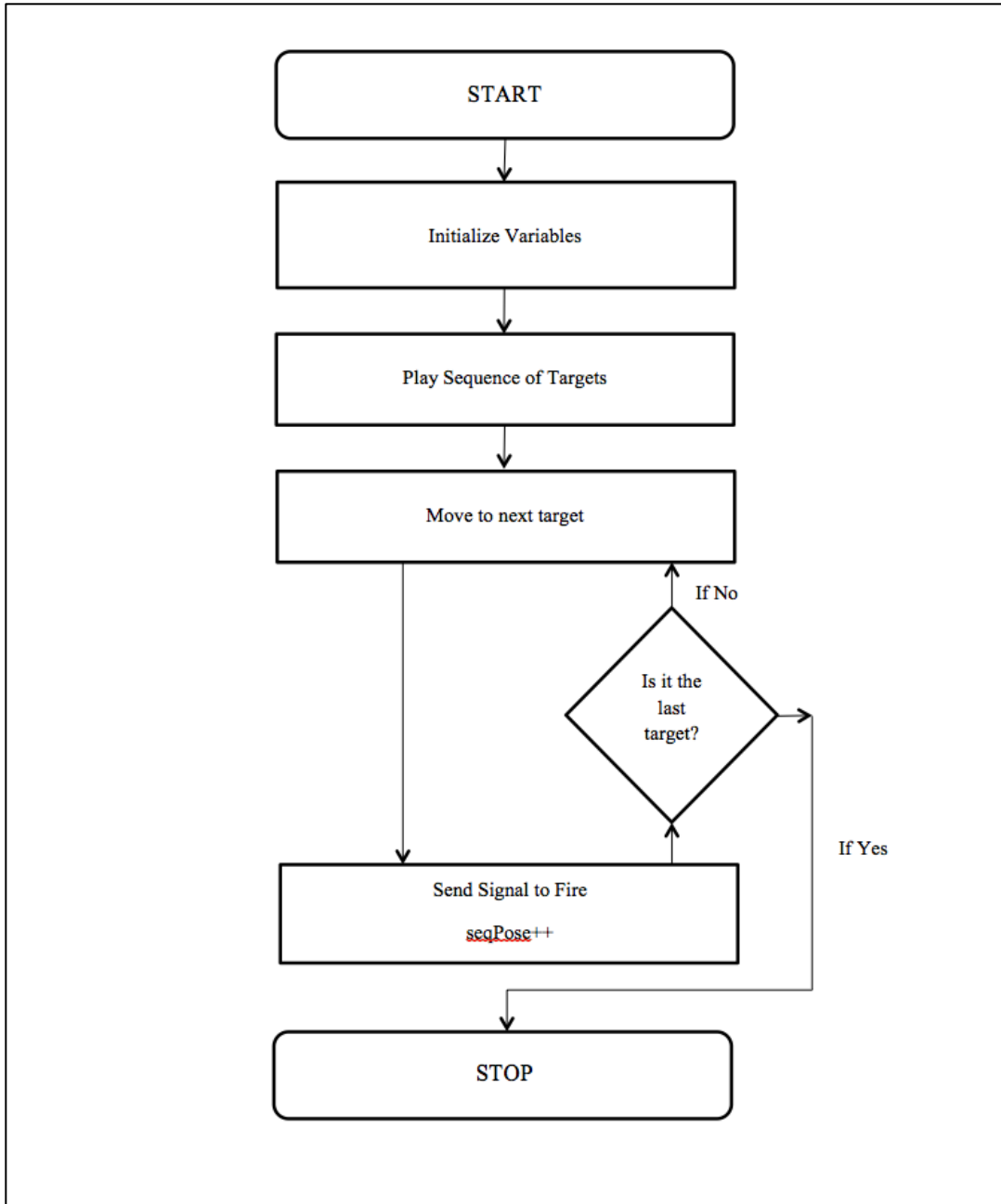

Figure 13: Motor Controller Flow Chart

Figure 13 shows a flow chart of the program used to run the firing system.

### Firing Mechanism

The A-5 Tippmann paintball gun was the chosen firing mechanism used to fire paintballs at any given targets depending on the user's input from the computer. The

Tippmann is a desirable gun to use due to the fact that it is lightweight, which will not put excessive amount of weight on the motors during operation. Adjustments will be made to preserve space for other components to fit within the design, such as shortening the grip and removing the physical trigger, which will also decrease the weight of the system. Also, an electronic trigger will be integrated into the gun so firing can be executed via a remote or a set programmable firing point. A long barrel is needed to ensure accuracy and maintain consistency during the duration of testing. The barrel will be purchased from Hammerhead paintball and it is called the Freedom Fighter. This barrel is 14 inches long, which is longer than the stock barrel, and increases the accuracy at longer distances. It is also rifled, which adds spin to the balls during flight to increase the ball's aerodynamic properties.

### Paintball Ballistic

The balls used in paintball guns are the same used in all guns. Paintballs are basically spherical objects with a thin outer membrane and paint contained inside the membrane. There are many types of paintballs designed for different purposes, so the choice depends on the user's desired results. Evil paintballs are basic paintballs used in many paintball guns. These balls are cost effective and have different sizes to accommodate any barrel. Upon impact, the evil paintballs splatter after impact, which make measuring the center mark after impact difficult. G.O.L.F. ball paintballs are newly designed paintballs, which improve the aerodynamics for longer flight and better accuracy. These paintballs are modeled similar to real golf balls, with a dimpled surface, and these dimples are the reason for better flight aerodynamics. Another advantage to using these types of paintballs is that they have powder paint inside the membrane, therefore, after impact they will leave behind a powder point that does not run rather than a splatter. This point will allow measurement of the dispersion and accuracy to be simple and straightforward with much less guesswork when finding the center of impact. Some calibration will be needed to account for gravity and other natural occurrences.

### Q-Loader

Hoppers are the basic component used in paintball guns to house and feed the paintballs into the gun's breach during firing. For this specific design, the Q-Loader

Hopper will be used to house and feed paintball into the tracking system. The advantages to using a Q-Loader hopper instead of a regular hopper are the Q-Loader has flexible feeding tube, which makes it easier to implement into the system without adjusting any other components to ensure there is enough space. Unlike the basic hopper, the Q-Loader feeds the paintballs into the chamber by using a spring mechanism, which prevents jamming during operation and also prevents the paintball from prematurely bursting while in the chamber. Also, with the spring mechanism, the Q-Loader hopper can feed against gravity, which will not limit the different positions the tracking system will be placed in during operation.

### Nitrogen Pressure System

The pressure system in a paintball gun is the basic component used to propel the paintball through the chamber and to its designated target. Generally most paintball guns use a gas pressure system to fire the paintballs at targets. The common gases used in the pressure system are carbon dioxide, air, and nitrogen. Testing will be done in an outdoor environment resulting in different temperature changes, depending on the time of year. Due to the outdoor environment, nitrogen will be the pressure system used for the tracking system. Nitrogen can maintain a stable pressure at different ambient temperatures, which is a desirable advantage to counter the fluctuating temperature difference. Also the customer provides nitrogen on the testing site that allows for the budget to be unaffected due to nitrogen refill.

### Engineering Economics

Shown in Table 2 is a list of parts and materials that were purchased using a budget of \$2000 from the FAMU-FSU College of Engineering Mechanical Department. Because accuracy and repeatability are important requirements of our system we chose to test two different types of paint for their accuracy and dispersion. We chose to compare the Rap4 G.O.L.F. paintballs to the higher quality regular paintballs. Since the G.O.L.F. paintballs were more expensive, we only purchased the minimum package of five hundred for testing. Based on our budget we decided to obtain a paintball marker between the range of \$300 to \$400. We originally purchased one 14 inch aftermarket

barrel from Hammerhead paintball, but after discussing our project with the president of the company, for the same price he gave us an entire barrel kit containing one 14 inch barrel, one 16 inch barrel, a ball gauge, and an assortment of ball sizers, each dimensioned to a specified ball size. Next, an air supply and hose were needed to fire the gun. The air hose was needed to reduce the weight on the gun itself. This allowed for the bottle to be removed from the gun and placed elsewhere in the system. Two RX-64 motors were purchased with a package that also came with the microcontroller, brackets & hardware, and a RX bridge. The bridge allows the bigger RX motors to be compatible with the controller. A wireless receiver and remote were also purchased for the microcontroller. These allow for wireless communication with the controller and thus the motors. Finally, assembly materials such as 6061 aluminum sheets, an assortment of bolts, nuts, washers, and a keyed switch were purchased. The keyed switch added another level of safety when dealing with the firing mechanism of the gun. After everything was purchased we were under budget by \$69.40. One thing to note is the two larger EX-106 motors were purchased by our client at Eglin, both costing \$500 a piece. The costs of these motors were not included in the budget breakdown.

**Table 7: Budget Breakdown**

<b>Materials</b>	<b>Quantity</b>	<b>Price</b>
GOLF Paintballs 500ct.	1	\$40.01
Regular Paintballs 2000ct.	1	\$105.41
Tippmann A-5 Marker	1	\$368.45
Hammerhead Barrel Kit	1	\$59.00
Air Tank	1	\$129.90
Coiled Hose	1	\$30.00
RX-64 Motors	2	\$559.80
Brackets & Hardware		\$91.60
Wireless Receiver	1	\$21.95
Wireless Remote	1	\$24.95
Controller & Bridge	1	\$139.94
Assembly Materials		\$360
<b>Total</b>		<b>\$1,930.60</b>
<b>Remaining</b>		<b>\$69.40</b>

## **Experimental Procedure**

### **Gun Accuracy Test**

The gun accuracy test is used to determine the most accurate combination of ammunition combined with gun barrel length and type. The equipment and setup necessary to perform this test is as follows. The Tippmann A5 paintball marker with an electronic triggering system is the main component of the test and will be used in every test fire. The air tank must be connected to the paintball marker and filled up to at least 1,000 psi. Although the gun system can still fire at this pressure, we found through testing that the velocity would fluctuate significantly more than normal when the air supply was less than the 1,000 psi mark. Before beginning the test, separate all the ammunition according to paint type and ball size. In our case, there are two different types of paint, the Rap4 G.O.L.F. paintball and the tournament grade Evil paintball. Then, using the ball gauge provided by Hammerhead Paintball shown in Figure 14, the ammunition was then further divided into sizes based on their diameter, ranging from 0.679 inches to 0.690 inches. These gauge sizes correspond to the fin sizes, which are also shown in Figure 14. These fins are screwed in between the breach of the gun and the barrel and are sized to fit as tightly as possible around each round that passes through. This ensures a maximum seal around the paintball as it travels through the barrel, which increases the guns efficiency and repeatability by reducing pressure loss from behind the ball that would normally fluctuate from shot to shot without the fin in place.

**Table 8: Hammerhead Barrel and Components**



1	16" Hammerhead Battlestix Barrel
2	14" Hammerhead Battlestix Barrel
3	Different Gauged Fins
4	Ball gauge sizing tool
5	Barrel Muzzle

**Figure 14: Hammerhead Barrels and Components**

Also necessary for the testing is a target that needs to be setup at the maximum range, which is twenty-five meters in this case. The target needs to be big enough to at least encompass the minimum area of desired accuracy. We were trying to shoot within one degree of dead center from twenty-five meters away, which is a circle with a radius of about 8.6 inches. The target that was used in this experiment measured to be thirty inches by thirty inches and was made of wood and is pictured in Figure 15. It is not necessary to mark anything on the target before testing begins.



**Figure 15: Target Setup**

The key component to this testing is minimizing as many variable as possible. One of the most critical variables that must be eliminated is the movement of the gun from shot to shot. This test is to see how accurate the paint and barrel combination is, and if the gun is moving in between tests, then the data is no good because there would be no way of knowing where the gun was aiming for each shot, making it impossible to measure its dispersion. There are many ways of anchoring the system so it does not move, the best being a gun vice that is made for this specific purpose. Unfortunately, we were unable to obtain a gun vice, so we had to make our own stabilizing system shown in Figure 16.



**Figure 16: Gun Stabilizing System**

Figure 16 shows the gun and barrel system being supported by a cinder block and backed by bricks, which allows the gun to stay at the same elevation and distance for each shot. One of the most important pieces of equipment used to make sure that the vice did not move is a laser. This laser would be placed in the barrel of the gun to help bore site the gun to know exactly where the gun was aiming for each test. The last piece of equipment is a ruler and some spray paint. The ruler is used to measure the distance from bore center for each shot and the spray paint is to cover up shots that have already hit the target. If previous shots are not covered up, then the target can get cluttered and it can become tough to determine one shot from another.





**Figure 17: Gun Range Test Setup**

Above, Figure 17 shows the final range setup for the accuracy testing. The following is the procedure used to determine the best system setup for accuracy. The following is the procedure used for testing. The first step is to determine which ball type, ball gauge size and type of barrel that is being tested. Match up the ball gauge size to the correct sized fin that gets screwed into the gun. Next, secure the system at twenty-five meters from the target, measured from the tip of the barrel, making sure that the electronic trigger is turned on and the air supply is screwed in. In our case, the system was secured with a cinder block, some bricks and towels as shown in Figure 17. We would suggest using a gun vice to secure it if available, but we were unable to obtain one.

Now, using the laser, place it in the barrel and turn it on to show the bore center on the target down range. Make sure it is centered as much as possible, and then mark this point, as it will be the center point from where all the measurements will be made. Now remove the laser and load the gun with five shots making sure the safety switch is on and no one is down range. Remove the safety and fire all five shots. The reason only five shots are fired is because the impact marks start to overlap the more shots that are on the board. Once all of the shots have been fired, place the system back on safety and, using a measuring device (we used a ruler), measure and record the distance in both the x and y directions from the center of each shot. Repeat the rounds of five shots until at least fifty shots are recorded. Now remove the gun, making sure no ammunition is inside and it

is on safety, and change out the barrel or fin to the next size test. Repeat the steps to record fifty shots for all possible barrel and paint combinations.

Note that a chronograph was not used during this test. It was discovered that the Tippmann A5 system that we are testing with does not have a built regulator, so the muzzle velocity from shot to shot could fluctuate almost twenty feet per second. And because we had no control over this fluctuation, we did not use a chronograph to record the velocity for every shot. We did, however, during a separate test, use a chronograph to get an average velocity for the system by taking about twenty shots per barrel size and averaging the velocities. This gave us a ballpark muzzle velocity that we could expect to see when doing our above accuracy testing.

### **Latency Test**

The latency test is used to see what the time is between the user sending a signal and the system responding. One of the necessary components for this test is Arbotix Robocontroller, which is the controller running the system. This is where all the commands originate, so it is key to this test. Next, the Dynamixel RX-64 motors are needed, since the firing system will not fire unless they are positioned in the right direction. They are daisy chained to the controller with an RS-485 Molex cable.

The next component is digital relay that is connected to the controller. This is the gate that opens and closes the circuit that fires the system. This is important because this is where the latency will be measured from, how long it takes for this gate to open after the signal is sent. Since this test is going to be done hardwired to the computer and over a wifi signal, the wifi connections are necessary. These are the two Xbee radios, one that is connected to the designated port in the Arbotix controller and the other that is connected to the computer through a USB cable. The configuration is shown in Figure 18.

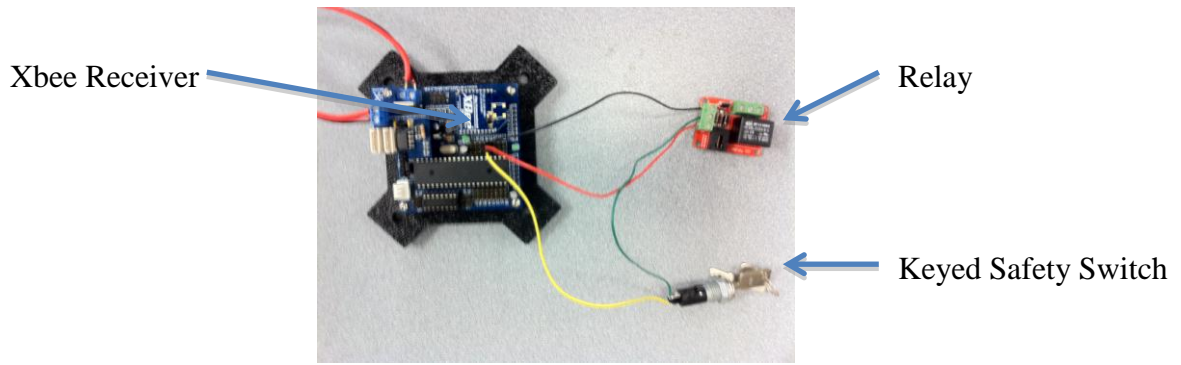

**Figure 18: Latency Test Setup**

The testing for the latency is fairly easy setup. The first step is to program a counter that initializes when the program starts running. It will count up as the program runs until it gets feedback that the system fired, and then the counter stops. This test was run connected directly to the computer, with the Wi-Fi sitting right beside the computer, the wifi signal being sent across the room, and the Wi-Fi being sent down a hallway. The final counts were the output and then calculated into a time.

## Results and Discussion

Shown below in Figure 19 is the total shot dispersion for the entire accuracy test. Out of five hundred and two total shots taken with every type of barrel and paint, only three hundred and three shots actually hit within our one-degree target of accuracy. This gives our system a total accuracy of only 55.8%, which is an extremely low percentage, considering the necessary shot accuracy needs to be upwards of 90%. In Figure 19, it actually looks like a higher percentage than 55.8% hit the target, but there were actually a couple of paint and barrel combinations that would completely miss the target board, which drove the accuracy percentage down and were obviously unable to be charted on this figure.

The main reason for this dispersion is the fact that the gun system does not have an active pressure regulator system. It was discovered that the gun only has a plastic tab that can be opened or closed to allow more or less air in per shot. This is a very imprecise way of regulating the pressure on each test fire, which resulted in very irregular ball velocities and flight patterns. The gun system does have a regulator in between the air tank and the gun that drops the pressure from 3000 psi to around 600 psi. In a higher end system, this compressed air would then pass through one or even sometimes two more regulators that have the ability to produce the exact same shot pressure every single time. This will produce the exact same muzzle velocity and the exact same ball flight pattern every shot, which could then be easily calibrated to hit the center target on command. Due to budget constraints, we were unable to purchase a gun system with this kind of pressure regulator, which hurt the accuracy of the system as seen in Figure 19.

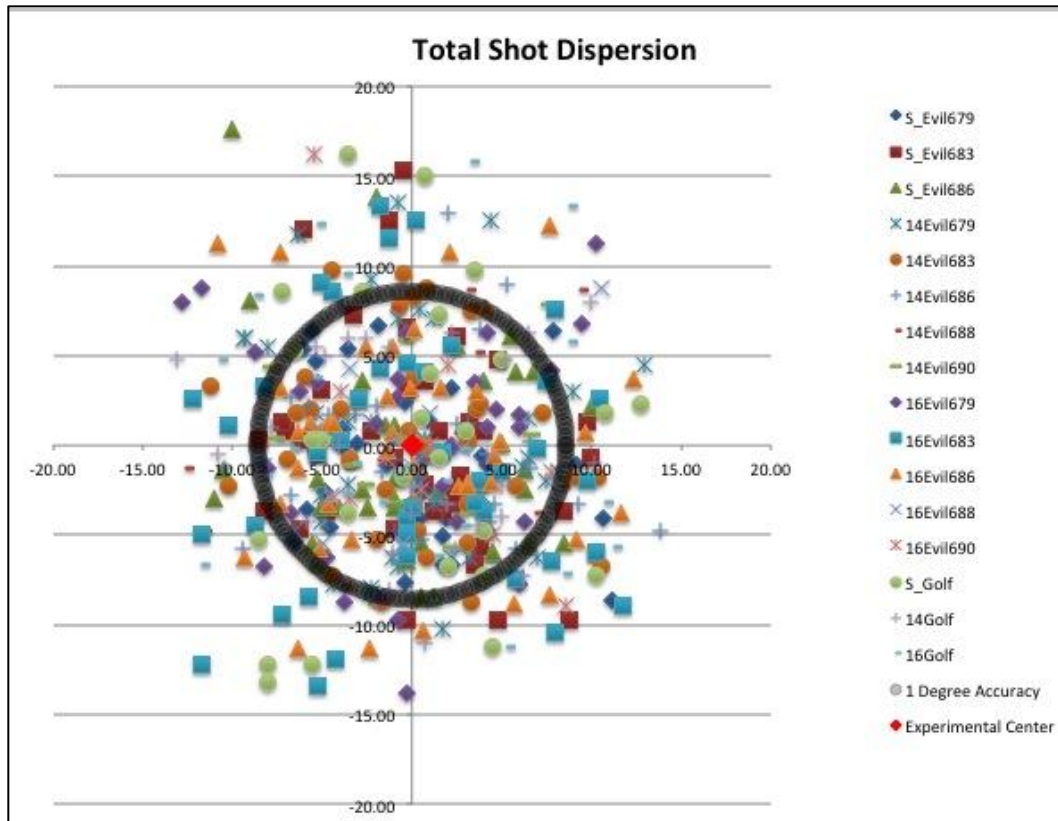

Figure 19: Total Shot Dispersion

This chart shows all of the shots with both types of paint, the Evil and the G.O.L.F., and their dispersion on the target. After completing the testing though, it was very clear from watching the flight of the paintballs that the G.O.L.F. paintballs were much more sporadic and inconsistent, which also contributed to such a low total accuracy. This will be clearer in the following graphs, but numerically comparing the accuracy of the two different paints, the Evil paint had an overall accuracy of 60.4%, while the G.O.L.F. paintballs only had an accuracy of only 38.8%.

There are two major reasons that lead to these inconsistent shots by the G.O.L.F. paintballs, more so than the Evil. The first and most noticeable factor is the way the balls are made. They consist of two hard wax dimpled hemispheres that are joined together and filled with chalk. The dimples are supposed to act like the dimples on a golf ball, creating a more turbulent flow around the ball, therefore increasing the angle at which the flow separates and decreasing the balls wake region, which allows the ballistic to travel farther and straighter in theory. In reality, a large seam area with no dimples is created at the

point at which the two dimpled halves are joined. This area not only has no dimples, but also stands out from the rest of the ball. When this ball is fired through the gun, depending on the orientation of the seam, the flight is very unpredictable and inconsistent at best. This is probably the largest contributing factor to the poor accuracy.

The other factor that decreases the G.O.L.F. paintball accuracy is their size. Most of these balls have a gauge size of 0.679, and most paintball guns suggest a gauge of 0.683-0.686 or higher. Since these balls do not fit as tight when traveling through the barrel, it will sometimes allow some of the pressurized air that is behind the ball to leak around the edges. This creates inconsistent pressure for each test shot, which leads to unpredictable ball velocities and ball flight for each shot. This happens because, when air is allowed to leak around the ball, it starts to create a high-pressure region in front of the ballistic as it exits the barrel. This creates a smaller pressure differential as the ball travels through the barrel, causing the ball to have a slower velocity as it exits the muzzle. The air leak is unpredictable because it can also be influenced by the orientation of the seam on the ball as it enters the gun, which varies for each test.

The graphs below show the data collected from the tests and separated into graphs based on the ballistic used and the type of barrel on the gun. All of the graphs are in inches. The ring on each graph represents the sixteen-inch diameter ring that would be within one-degree of dead center at a twenty-five meter shot. The center of the ring is the calibrated center of each test combination. All of the data of a test would be collected, and then the coordinates were averaged to get the calibrated center for that test due to gravity and other variable factors. Some of the rings look distorted due to the scattering of the data and the limited area to graph them in, but they are all exactly the same size.

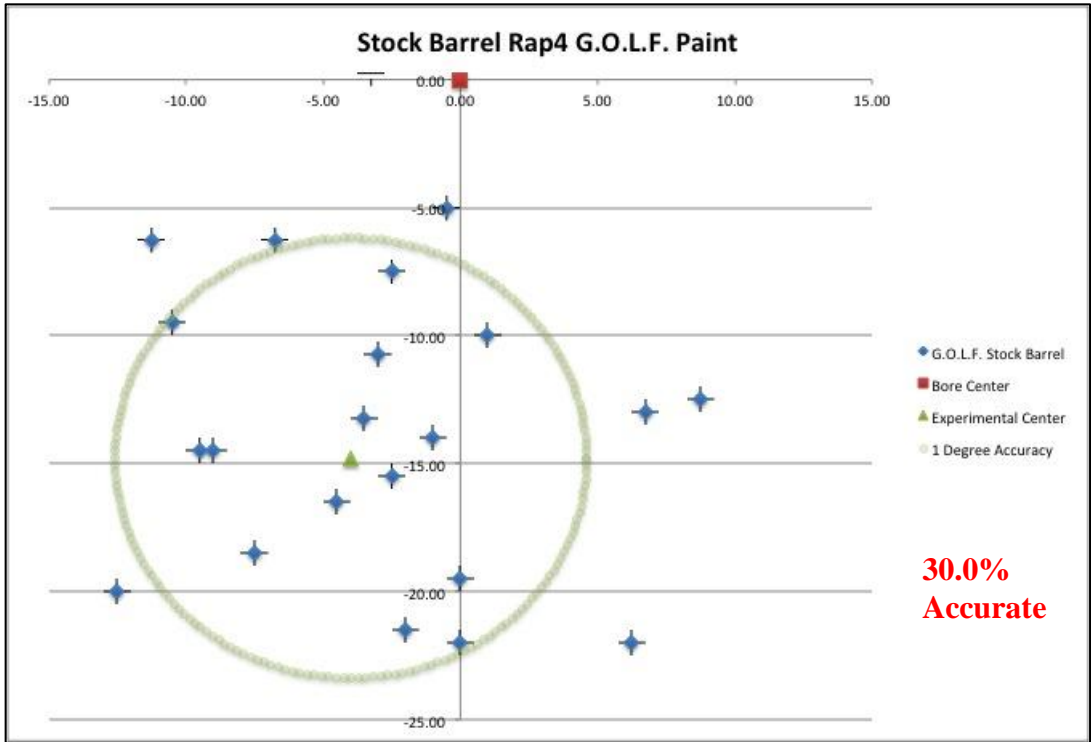

Figure 20: Stock Barrel Rap4 G.O.L.F. Paint Test Data

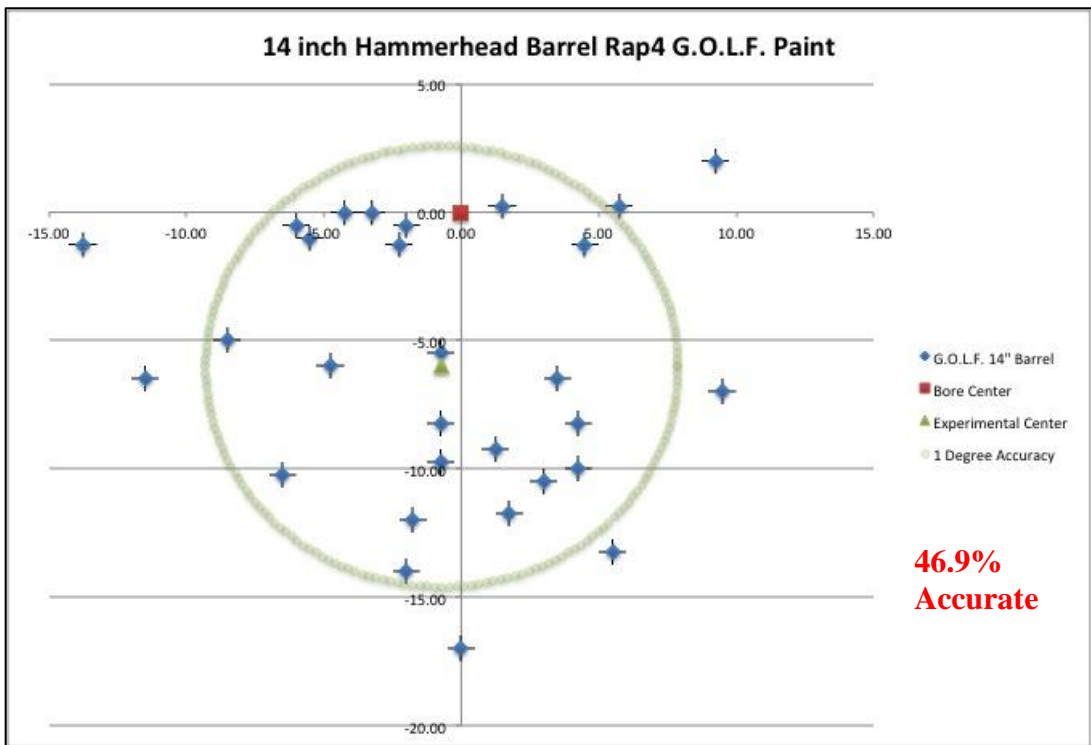

Figure 21: 14-inch Hammerhead Barrel Rap4 G.O.L.F. Paint Test Data

Figure 20 and Figure 21 show the inaccuracies of the Rap4 G.O.L.F. paintballs not only with the unrifled, shorter stock barrel, but also with the longer rifled hammerhead barrel that also has an air feedback system. Both of the tests represented in Figure 20 and Figure 21 had fifty shots fired at the board that was acting as the target. Out of the fifty shots, only twenty-seven even hit the board using the stock barrel, and then only fifteen of those actually hit within our target range of one-degree. This is clearly shown in Figure 20 because the target ring is very empty compared to the other test data. The 14-inch Hammerhead barrel was slightly more accurate, with a 46.9% shot accuracy. This could be due to the longer barrel not allowing the ballistic as much distance to move off target, or that the rifling helped keep them straighter. Very similar trends were seen in the 16-inch Hammerhead barrel test, as it had an accuracy of 40.0%. It is clear from this data that the Rap4 G.O.L.F. paint is not the type of ballistic that our system needs to use to maximize the accuracy.

The other type of ballistic paint tested was tournament grade Evil paintballs. What makes these paintballs so good is their thick paint. It sticks very well to the walls of the shell, so as it spins in flight, it spins as one unit, whereas some paintballs have the outer shell and the inner paint spinning at two different speeds and in different directions. This paint varied in size much more than the G.O.L.F. paintballs did, therefore, it was really necessary to size them before testing. The graphs below show the data from the Evil paintball testing.



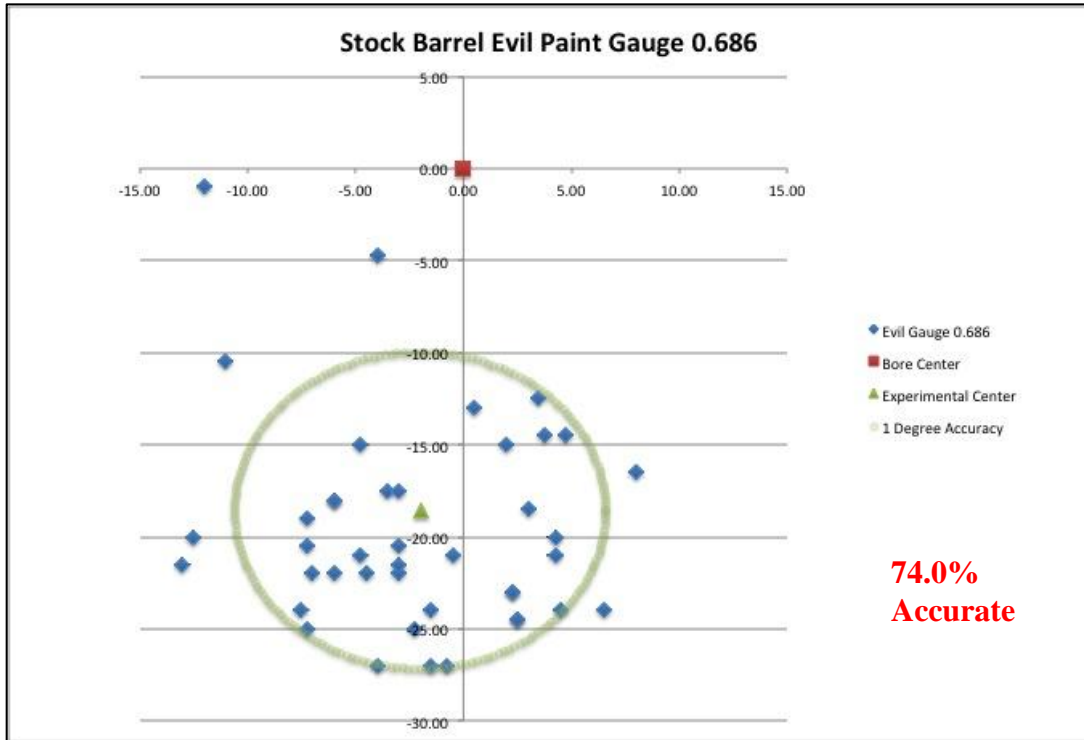

Figure 22: Stock Barrel Evil Paint Gauge 0.686 Test Data

Figure 22 shows the system shooting a 0.686 gauge Evil ball with the twelve-inch stock barrel that the gun came with. The 0.686 size is right in the middle as far as sizing goes, so it is a good representation of the stock barrel shooting the other size balls. The most significant difference between the stock barrel shots and the Hammerhead barrel is the amount of drop in the ball. The calculated distance to calibrate for that would be about twenty inches, which is a pretty large move. But as Figure 22 shows, this system hit the target 74.0% of the time and had very little variation from left to right. Most of these misses were low, which more than likely had to do with not having a proper regulator to get enough air behind the shot.

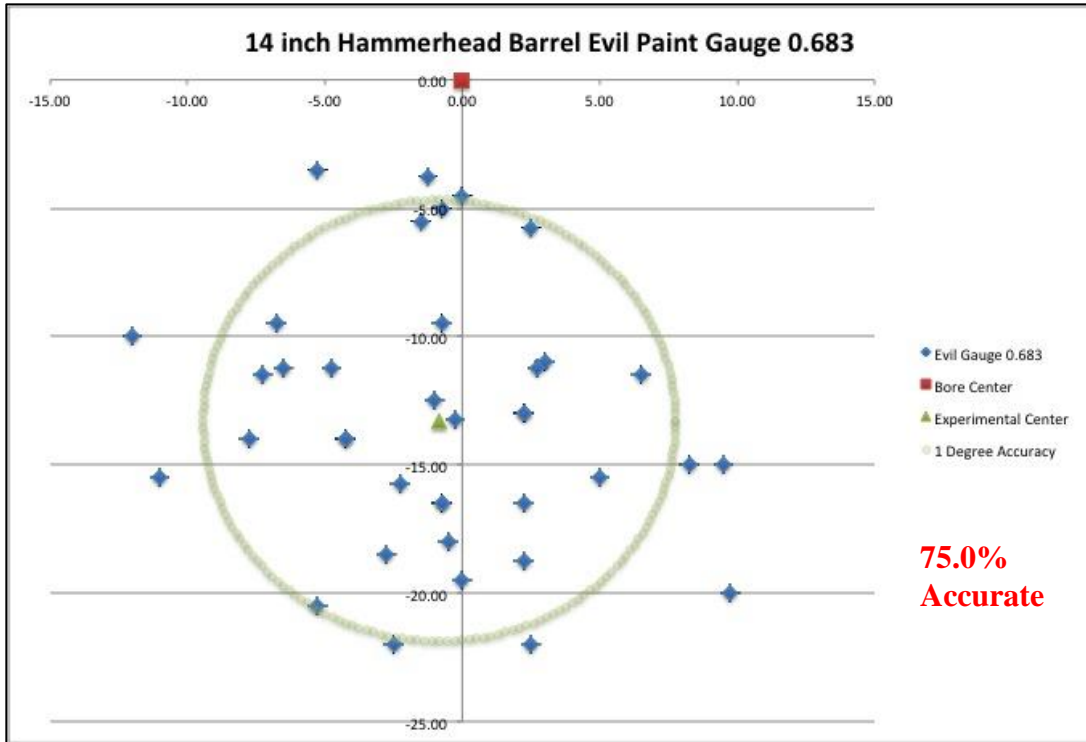

Figure 23: 14-inch Hammerhead Barrel Evil Paint gauge 0.683 Test Data

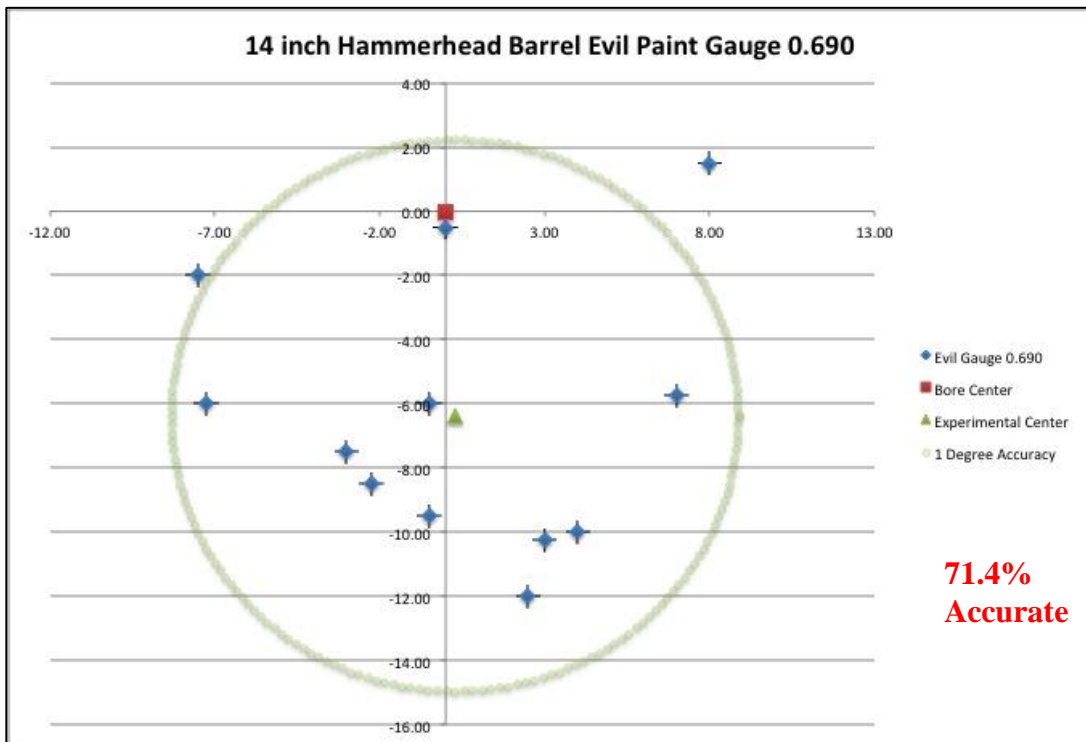

Figure 24: 14-inch Hammerhead Barrel Evil Paint gauge 0.690 Test Data

Figure 23 and Figure 24 show the dispersion of gauge 0.683 and 0.690 Evil paint, respectively, with the 14-inch Hammerhead barrel attached. Figure 23 shows the most accurate combination of all the testing with the 0.683 Evil. This combination was on target 75% of the time, well over the average, and was within close range on every single shot. One thing that this combination did not do that seemed to be prevalent with the Hammerhead barrels was the shots did not tend to yaw or pitch left and right as much. Although the rifling of the barrel allows for the balls to fly on a much flatter flight path, sometimes it could cause the ballistic to want to tail off to one side or another. The spinning of the ball would create lift on one side of the sphere or the other do to the change in flow characteristics, and the larger the force, the more the movement. This yawing motion was fairly unpredictable in most other tests, but the 14-inch Hammerhead barrel with 0.683 Evil paint flew a lot straighter as shown in Figure 23. Since this system was affected by gravity, it was calculated that the system needed to be calibrated 13.3 inches high to be dead center target.

Figure 24 shows the same barrel with the largest paint, the 0.690 Evil. The reason for showing this graph is that Hammerhead contacted us and told us that the larger paint in the size range is more likely to be the most accurate. Unfortunately, paint this large is more rare, and we did not have enough shots to conclusively agree or disagree with their statement. But Figure 24 does show that in the fourteen shots, it had a 71.4% accuracy rate and was definitely a promising combination.

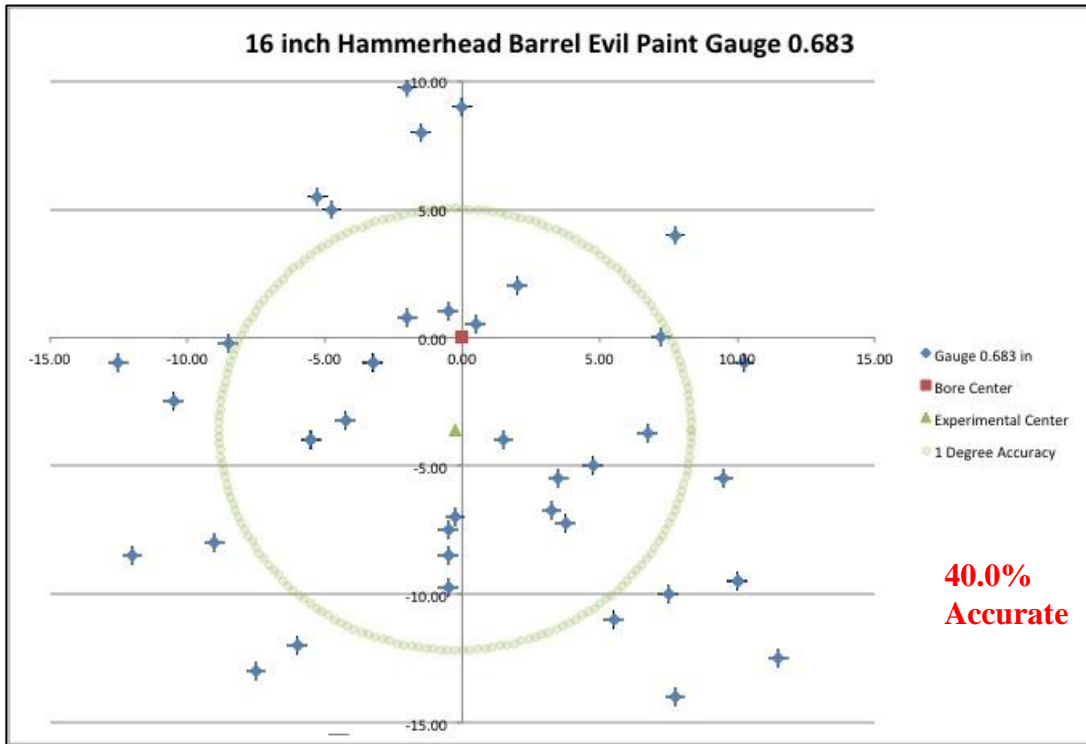

Figure 25: 16-inch Hammerhead Barrel Evil Paint gauge 0.683 Test Data

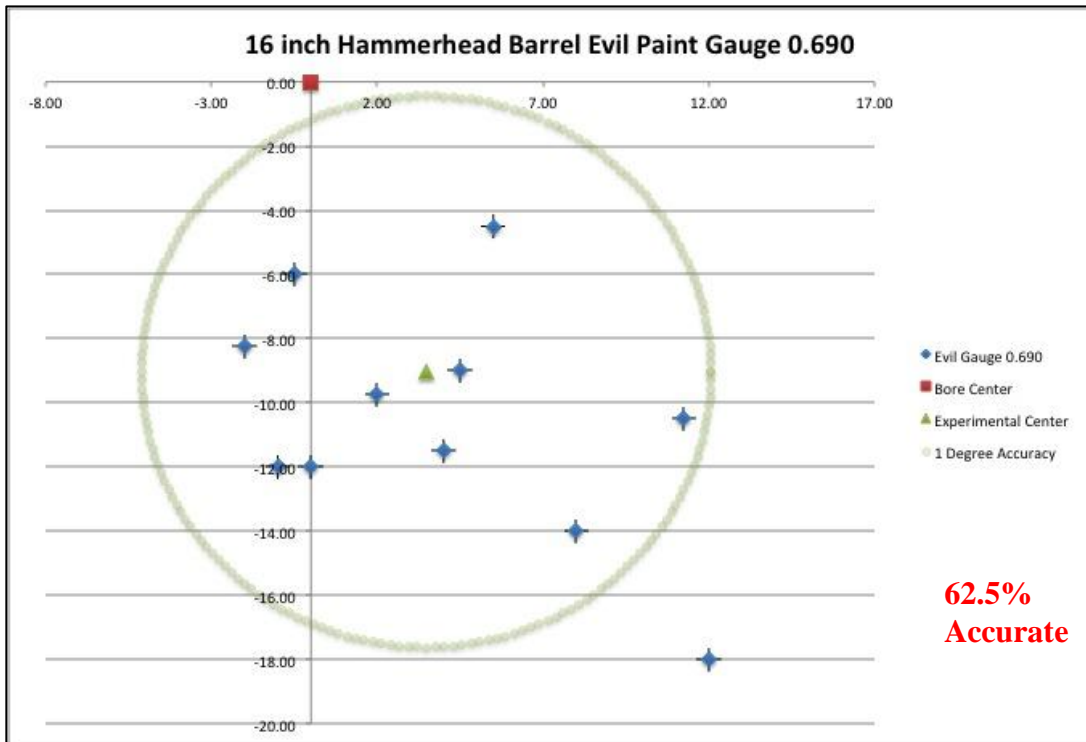

Figure 26: 16-inch Hammerhead Barrel Evil Paint gauge 0.690 Test Data

The graphs in Figure 25 and Figure 26 show the same gauge size as Figures 23 and 24, but with the 16-inch Hammerhead barrel. Figure 25 shows that the combination with the 0.683 Evil ball is very inaccurate. We do believe that the number is uncharacteristically low, and noted that the day this system was tested, there were large winds and some inclement weather. But both graphs show a much lower accuracy than their 14-inch barrel counterparts. One of the main reasons for this is the extra rifling down the barrel. We have concluded that the 16-inch barrel is too much rifling and puts too much spin on the ball, making it travel left and right a lot more than the 14-inch barrel. This idea is visible in Figure 25, where most of the missed shots are not high or low, but left and right of the circle. Most all of the other 16-inch barrel graphs reinforce the same idea.

The accuracy was only one portion of the data that the Air Force Research Lab was interested in. The fire latency was also a big concern our prototype, making sure that it sent and received signals in a reasonable time. This is very important when it comes to firing the system, because if the trigger is not hit at the exact time, the ballistic could miss its mark by a few feet and no one would know. After doing our testing, it was clear though, that the difference in range with the Wi-Fi signal device did not affect the system much at all. The fir signal was received a little faster when plugged directly into the computer, but it was in the microsecond range. This means that the signal being sent over Wi-Fi will not affect the timing of the triggering system.

## **Environment, Health and Safety**

In the C-CAT system, the post pressing issue when it came to health and safety was the fact that this is a live firing device. This system does have a potential weapon attached to it and under no circumstances should that weapon be able to fire unless expressly told to do so by the operator. The main way to avoid any unwanted discharge of the weapon is to remove the trigger and add a keyed safety switch to the circuit in between the relay switch and the electronic trigger board. Since the gun is going to be fired with a computer through the electronic trigger board, there is no need to even have the mechanical trigger on the gun anymore, which eliminates any accidental trigger pulls

by someone who is working on the C-CAT system. Also this keyed switch will be a simple on of circuit break between the relay and the trigger, so a fire command cannot reach the trigger unless the key is turned to the “ON” position. The last form of safety is within the programming itself. The program that operates the motors and motion of the turret system is a different program than what sends the fire signal. This keeps the system from accidentally firing while it is moving into place.

An environmental issue that our system could possibly cause is the ballistic paintballs being shot and left behind on the testing field. The paint used in the paintball is a non-toxic water-soluble substance mixed with a coloring dye to give a visual mark. Though the dye is not food coloring, manufactures practice extreme caution to ensure that the dye used for the coloring in paintballs is no more harmful than food coloring. Some higher-grade paintballs are mixed with cornstarch and metallic flakes to improve the thickness of the substance, which will show a better marking region for testing purpose, but it is all biodegradable materials that make up the ballistic. Some manufacturers even claim that their paintballs are so environmentally friendly that they would be edible for humans. We do not suggest trying to eat them any time soon, but the point is that any animals that were to find them after a test and possibly eat the residue would be in no danger or harm from doing so.

## **Conclusion**

The Munitions Directorate at Eglin wanted a way to fire a ballistic round to help see the accuracy and reliability of their fuze sensors. The Computer Controlled Aiming and Tagging System is a paintball gun based turret system that is controlled electronically to test these sensors. The system, first and foremost, needs to be as accurate as possible, making sure the mark left behind is where the system was supposed to be aiming. The Tippmann A-5 paintball gun is what was chosen for this project. It fit in the budget of the project, but was a little higher end than most off of the shelf paintball guns. Even though it was a little more expensive, it still had some major drawbacks as far as accuracy. The total accuracy of all of the data collection was only 55.8%. This is a very low rate and has a lot to do with a lack of a pressure regulator within the gun itself. This leads to unpredictable and wild shots. Our suggestion for increasing the accuracy would either be

to buy an aftermarket pressure regulator upgrade for the Tippmann or buy a much nicer high-end gun. The former would be cheaper, but not as reliable and would take man-hours to put together. The later would be much more expensive, in the \$800-\$1,000 range, but would have electronic regulators and would result in almost identical shots every time the trigger is pulled, giving the most accurate and predictable shots.

The poor accuracy was not only due to the lack of regulator, but also poor paintballs. The Rap4 G.O.L.F. paintballs are good in theory with the dimpled shell, but in reality they are very unreliable due to the seam that is created in the manufacturing process. The Evil tournament grade paintballs are the best paint to use for this system, since they are relatively heavy and will not be affected as much by wind and other elements, and also have a thick paint, which allows the whole ball to spin together as one piece, which gives a much flatter ball flight. The Evil paint does need to be matched with the right barrel. The Hammerhead 14-inch barrel is a rifled barrel that gives spin to the ball in flight. The spin helps the balls fly straighter, but too much spin can cause yaw to the left or right as seen by the 16-inch Hammerhead barrel. Therefore, the most accurate combination is the 14-inch Hammerhead barrel shooting the Evil paintball that has a gauge of 0.683. This combination was the most accurate, hitting the target 75.0% of the time.

The triggering system does have a few issues. Passing a magnet in between two Hall-Effect sensors fires the electronic trigger that came with the gun system. We were never able to get a full wiring diagram of the trigger board and the Hall-Effect sensors, which made it very tough to figure out how it needed to be wired to shoot. We were able to figure out how to wire it up and program it so that it sends the firing signal, but for some reason, the solenoid would not get the signal and would not fire. Therefore, our system is unable to fire a paintball electronically, which moving forward, would be a first major fix that needs to happen. To show that we do have a firing algorithm in place, we have wired an LED to light up when the gun should fire, and the relay makes a click sound when it completes its circuit as well.

The systems motors and controllers meet and exceed all specifications. The Dynamixel motors not only have the necessary torque to move the system, but also are smart motors. They can be manually moved to any location and know exactly where they

are without having to be calibrated. This is a great feature that keeps the user from having to calibrate the motors after every use because they are self calibrating. The one downside is in this system is the smaller RX-64 motors were used for both the elevation and the azimuth motion. The elevation motor is able to move as fast as necessary, but the azimuth motor is a little slower. Our recommendation is to use the larger EX-106+ motor for at least the azimuth motion. This would allow for faster and smoother motion in the system. The only problem with the EX-106+ motors is they communicate at a different rate than the RX-64 motors and the Arbotix controller, so it is necessary to go into the EX-106+ motors and rewrite their library code so they would be compatible, which we did not have the time to do.

In conclusion, the Computer Controlled Aiming and Tagging System meets all of the required specifications. As soon and the triggering mechanism can be solved, the system would be ready to be prepared to take a next step to the dynamic testing rig.



# Appendix

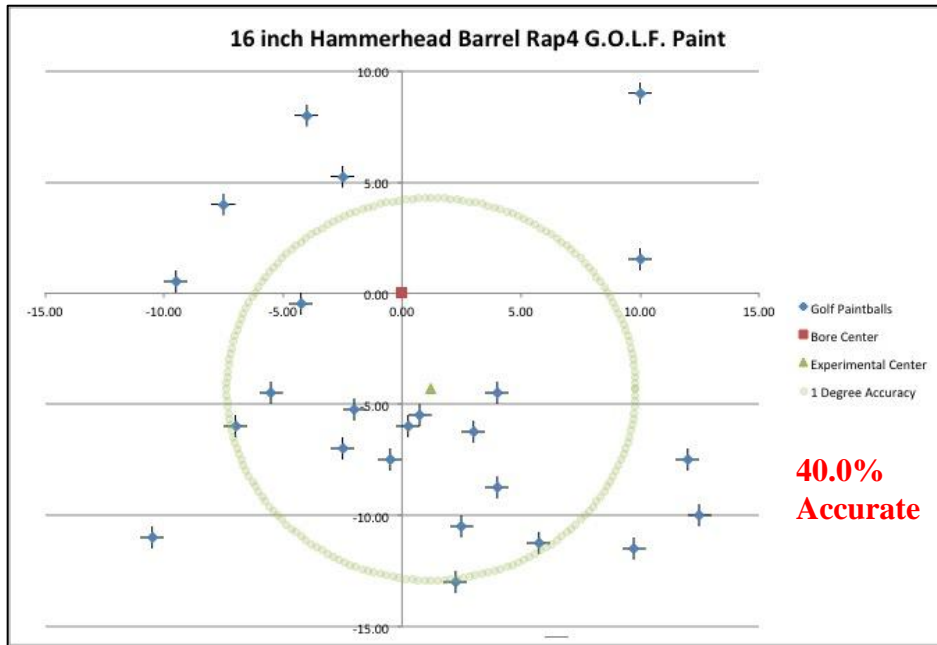

Figure 27: 16-inch Hammerhead Barrel Rap4 G.O.L.F. Paint Test Data

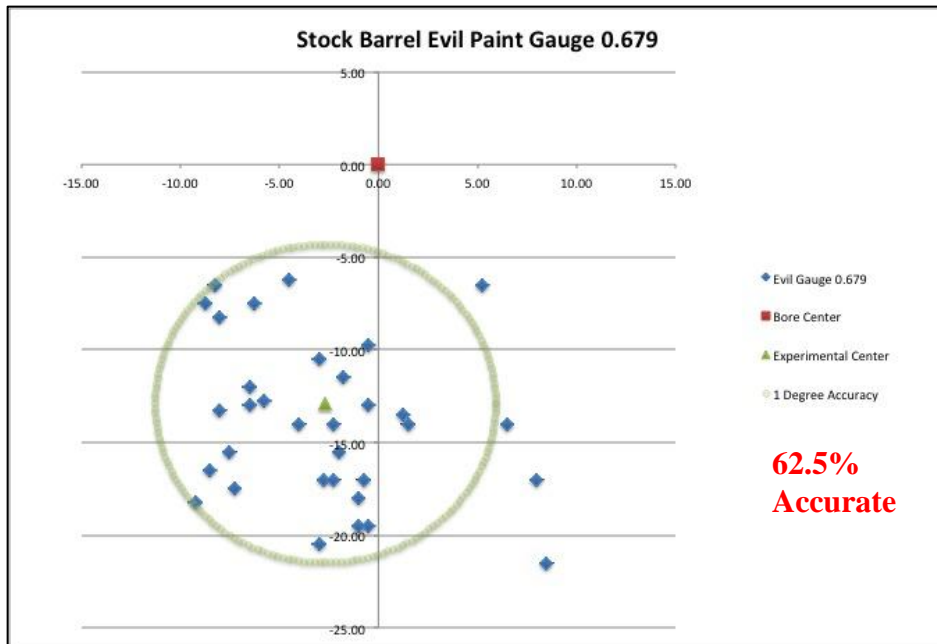

Figure 28: Stock Barrel Evil Paint gauge 0.679 Test Data

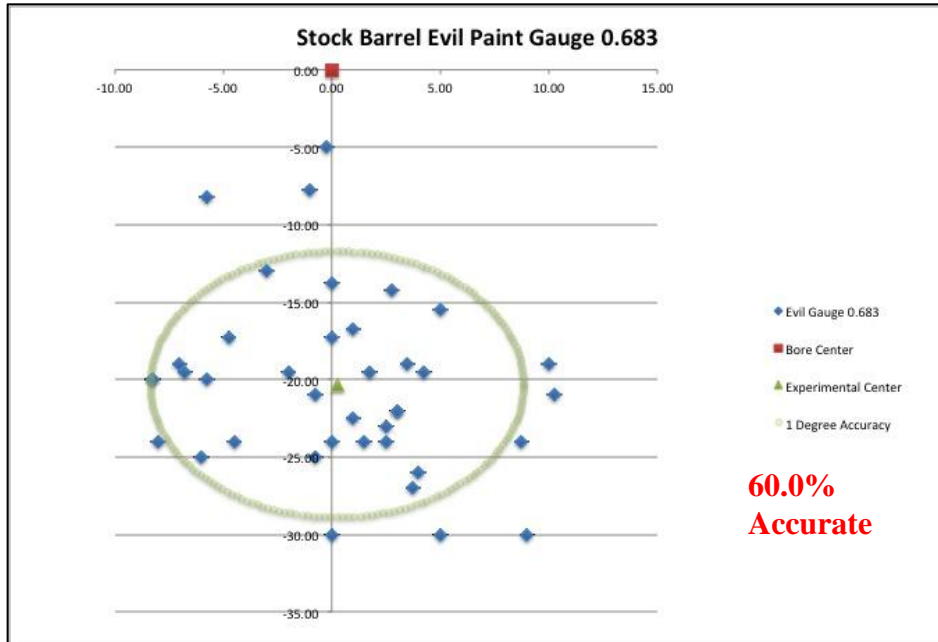

Figure 29: Stock Barrel Evil Paint gauge 0.683 Test Data

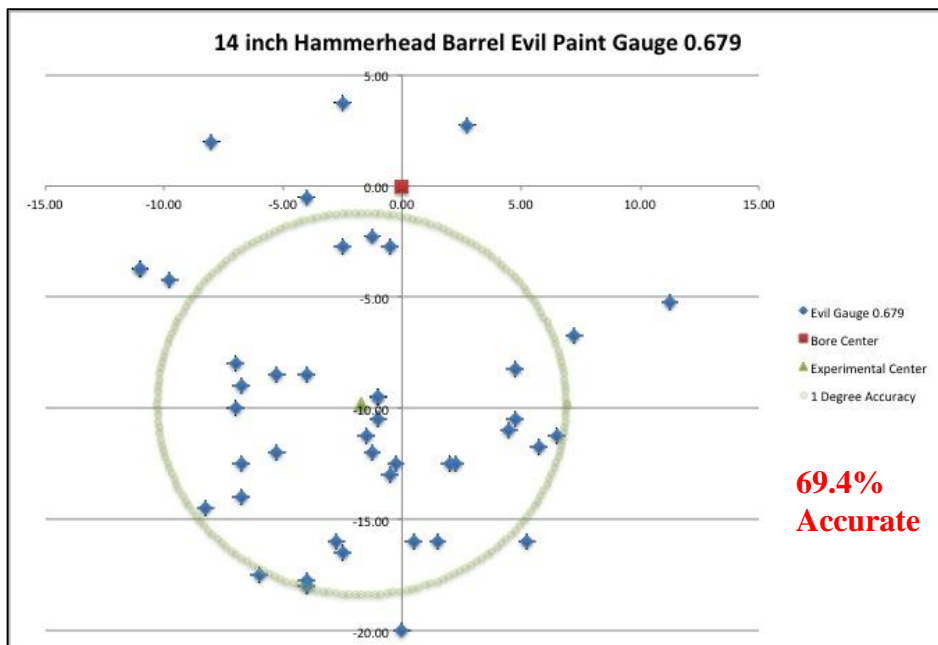

Figure 30: 14-inch Hammerhead Barrel Evil Paint gauge 0.679 Test Data

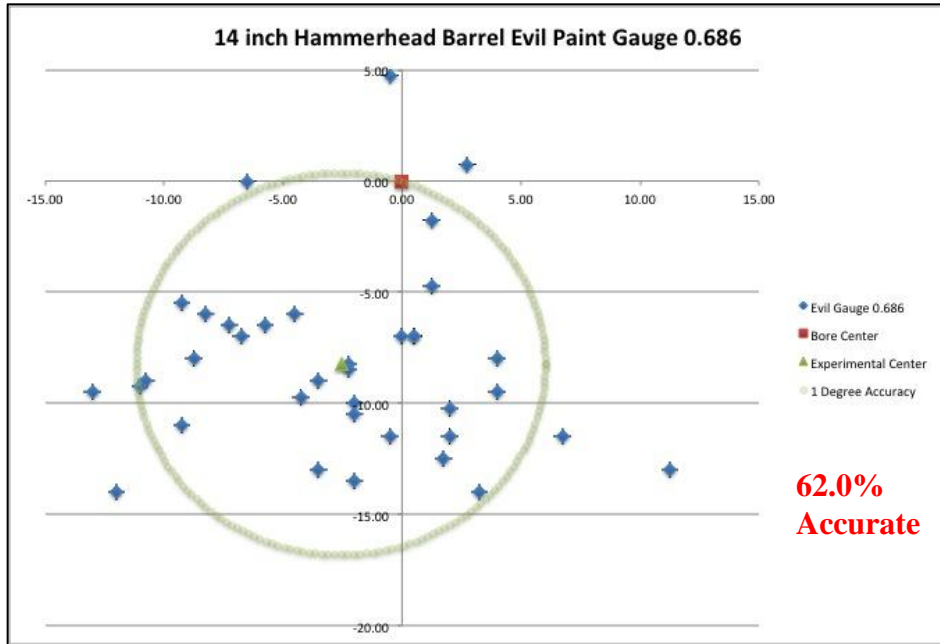

Figure 31: 14-inch Hammerhead Barrel Evil Paint gauge 0.686 Test Data

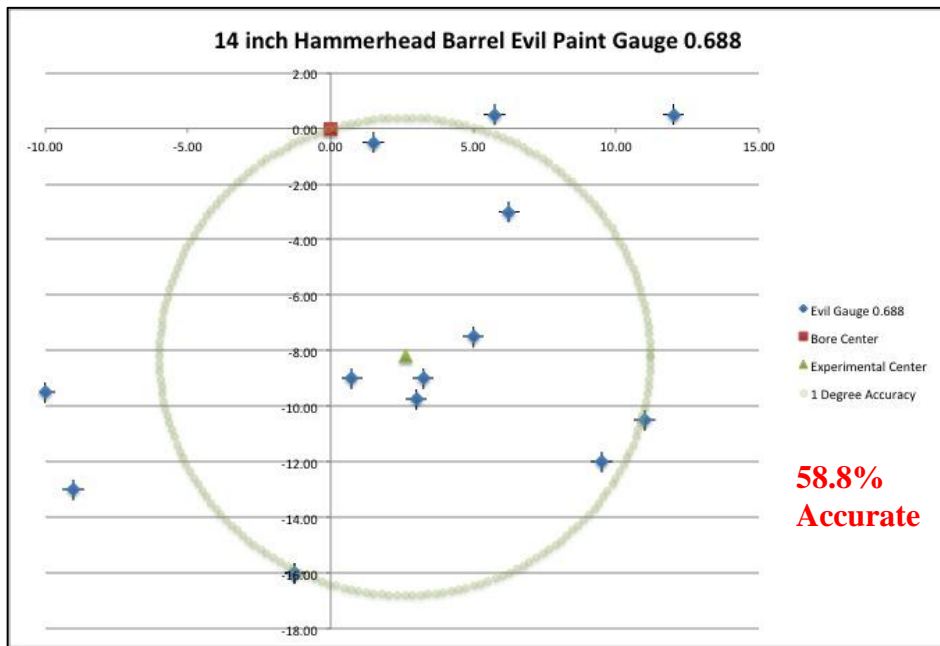

Figure 32: 14-inch Hammerhead Barrel Evil Paint gauge 0.688 Test Data

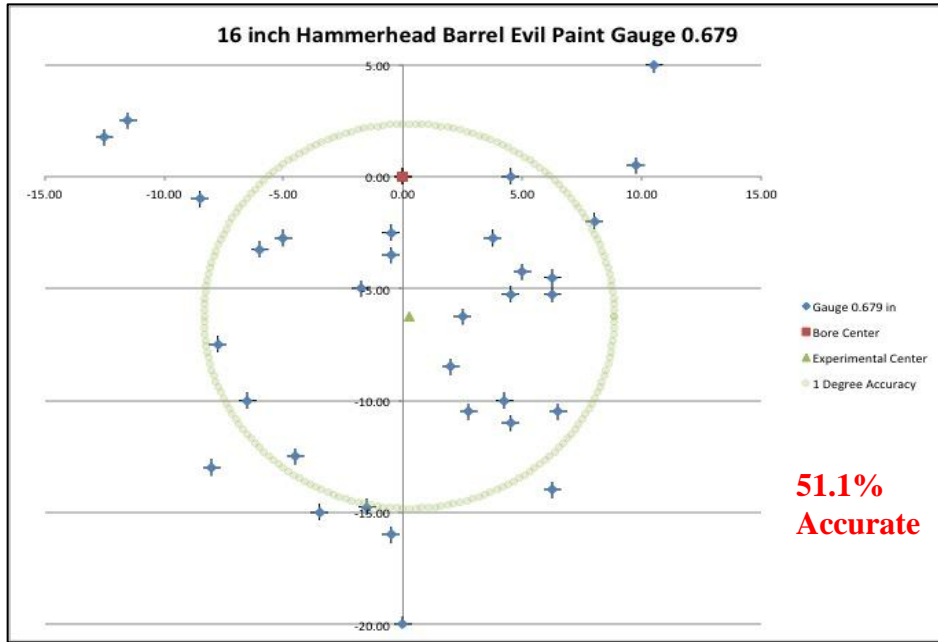

Figure 33: 16-inch Hammerhead Barrel Evil Paint gauge 0.679 Test Data

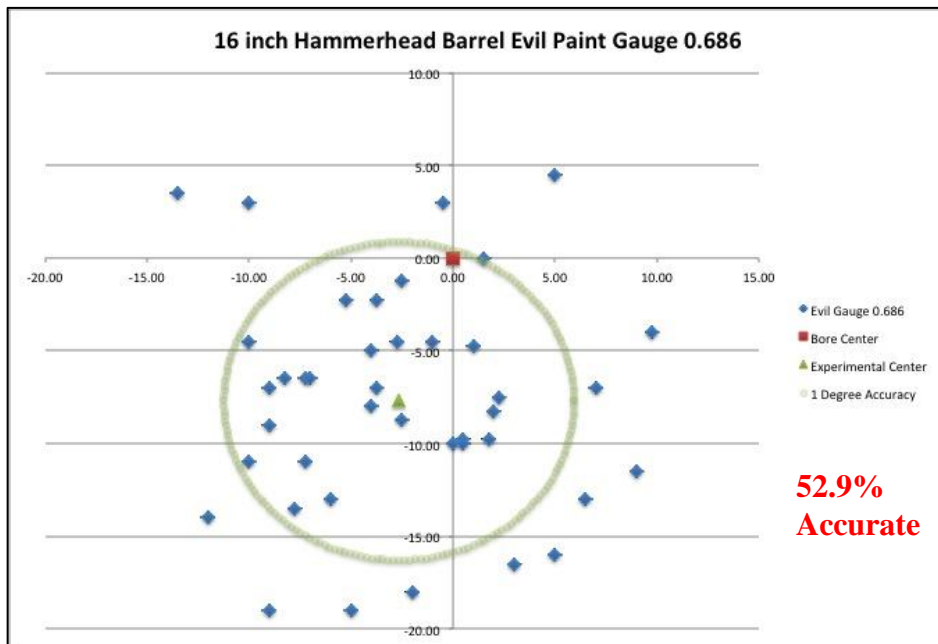

Figure 34: 16-inch Hammerhead Barrel Evil Paint gauge 0.686 Test Data

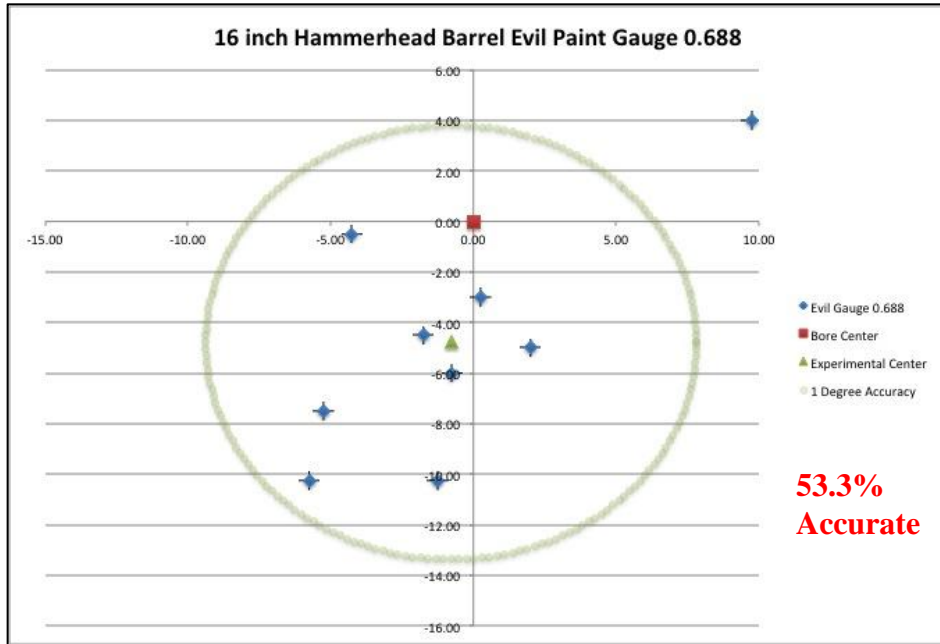

Figure 35: 16-inch Hammerhead Barrel Evil Paint gauge 0.688 Test Data

One-Degree Accuracy Target Calculations:

**Table 9: Example Accuracy Data (Stock Barrel Evil Paint Data Shown)**

0.679		0.683		0.686	
X	Y	X	Y	X	Y
5.25	-6.50	1.00	-16.75	-4.50	-22.00
-1.75	-11.50	-0.75	-21.00	-2.25	-25.00
6.50	-14.00	2.50	-23.00	2.50	-24.50
-4.00	-14.00	5.00	-30.00	2.50	-24.50
8.00	-17.00	10.00	-19.00	-7.25	-19.00
-0.50	-9.75	3.00	-22.00	-3.00	-22.00
-2.00	-15.50	3.00	-22.00	2.25	-23.00
-0.50	-19.50	-3.00	-13.00	2.25	-23.00
-4.50	-6.25	5.00	-15.50	-0.75	-27.00
-8.00	-8.25	-6.00	-25.00	4.75	-14.50
-6.50	-12.00	-0.25	-5.00	4.25	-20.00
-3.00	-10.50	4.00	-26.00	0.50	-13.00
-1.00	-18.00	8.75	-24.00	3.00	-18.50
-5.75	-12.75	-5.75	-8.25	6.50	-24.00
-1.00	-19.50	3.75	-27.00	4.50	-24.00
-0.75	-17.00	-4.50	-24.00	2.00	-15.00
-8.50	-16.50	-8.00	-24.00	3.75	-14.50
-8.25	-6.50	-1.00	-7.75	-11.00	-10.50
-2.25	-14.00	-8.25	-20.00	-3.00	-21.50
-0.50	-13.00	-8.25	-20.00	-0.50	-21.00
1.25	-13.50	1.50	-24.00	-4.00	-4.75
1.50	-14.00	0.00	-13.75	-4.75	-15.00
-8.75	-7.50	2.75	-14.25	-13.00	-21.50
-8.00	-13.25	-5.75	-20.00	-1.50	-24.00
-7.50	-15.50	-2.00	-19.50	-1.50	-27.00
-6.25	-7.50	3.50	-19.00	8.00	-16.50
-2.75	-17.00	-4.75	-17.25	-3.50	-17.50
-1.25	19.50	-6.75	-19.50	-12.50	-20.00
-3.00	-20.50	-0.75	-25.00	-4.00	-27.00
-6.50	-13.00	0.00	-24.00	6.75	24.00
-2.25	-17.00	2.50	-24.00	3.50	-12.50
8.50	-21.50	10.25	-21.00	4.25	-21.00
-7.25	-17.50	1.00	-22.50	-3.00	-17.50
-9.25	-18.25	9.00	-30.00	-3.00	-20.50
miss		-7.00	-19.00	-7.00	-22.00
miss		0.00	-17.25	-12.00	-1.00
miss		1.75	-19.50	-7.25	-20.50
miss		4.25	-19.50	-7.50	-24.00
miss		0.00	-30.00	-4.75	-21.00
miss		miss		-6.00	-18.00
miss		miss		-6.00	-18.00
miss		miss		-6.00	-22.00
miss		miss		-7.25	-25.00
miss		miss		miss	
miss		miss		miss	
miss		miss		miss	
miss		miss		miss	
miss		miss		miss	
Xavg	-2.66	miss		miss	
Yavg	-12.90	miss		miss	
% hit	70.8%	Xavg	0.25	Xavg	-1.99
% accurate	62.5%	Yavg	-20.31	Yavg	-18.58
		% hit	78.0%	% hit	86.0%
		% accurate	60.0%	% accurate	74.0%

## Engineering Drawings

**Table 10: Bill of Materials**

<b>Part #</b>	<b>Part Name</b>	<b>Material</b>	<b>Quantity</b>
1	BLOCK	Al 6061	1
2	BASE DISK	Al 6061	1
3	TURNTABLE	Galvanized Steel	1
4	GRIP BRACKET	Al	2
5	EX-106+ MOTOR		2
6	BACK BRACKET	Al	1
7	TOP PLATE	Al 6061	1
8	BIG TURNTABLE	Galvanized Steel	1
9	MOTOR PLATE	Al 6061	1
10	SUPPORT PLATE	Al 6061	1
11	Q-LOADER	Plastic	1
12	BRACE	Al 6061	2
13	PLASTIC PLATE	Plastic	1
14	GUN MOUNT	Steel	2
15	BOTTLE MOUNT	Al 6061	1
16	BOTTLE	Carbon Fiber	1
17	TIPPMANN A-5		1
18	14" BARREL	Al	1
19	NUT	Steel	24
20	TURNTABLE BOLT	Steel	4
21	SMALL BOLT	Steel	4
22	WASHER	Steel	8
23	LONG BOLT	Steel	4
24	BRACKET SCREW	Stainless Steel	28
25	8-32 SCREW	Stainless Steel	12
26	LONG SCREW	Alloy Steel	4
27	M2.5x13MM	Alloy Steel	16
28	SMALL NUT	Stainless Steel	21
29	½" BOLT	Steel	4
30	MOTOR BRACKET	Al	1

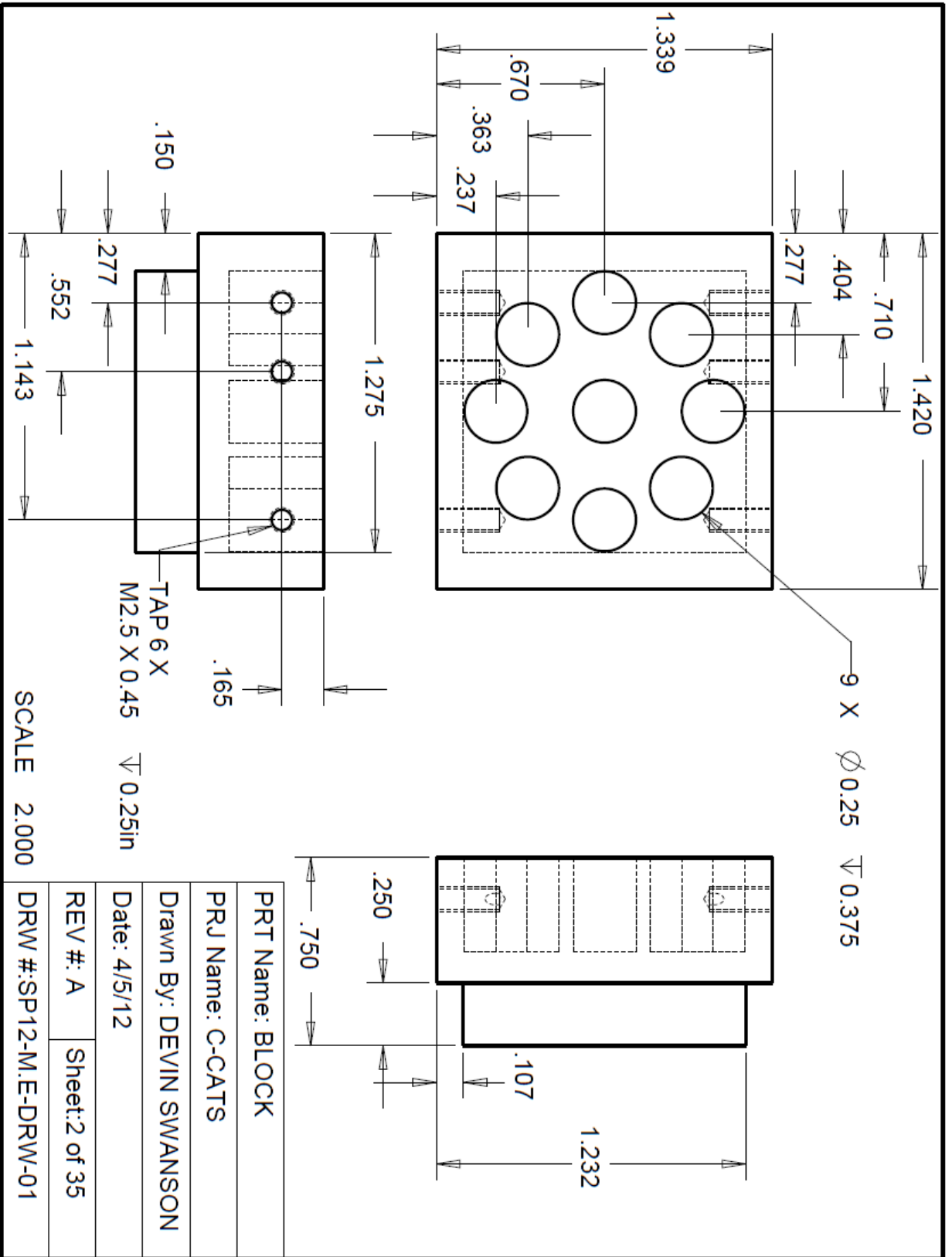



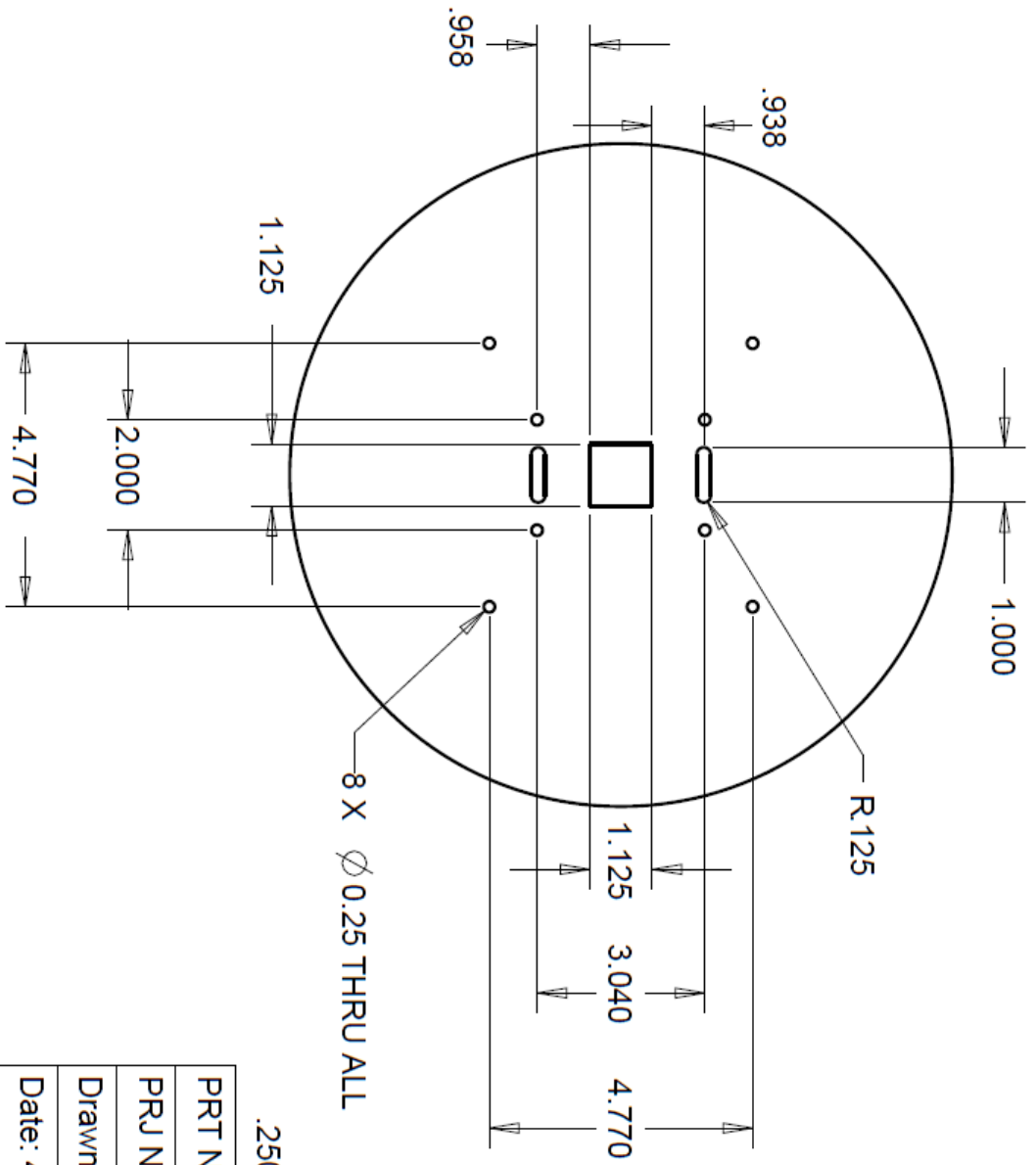

8 X  $\varnothing$  0.25 THRU ALL

R125

1.125 3.040 4.770

.250

12.000

SCALE 0.350

PRT Name: BASE DISK	
PRJ Name: C-CATS	
Drawn By: DEVIN SWANSON	
Date: 4/5/12	
REV #: A	Sheet: 3 of 35
DRW #: SP12-M.E-DRW-02	

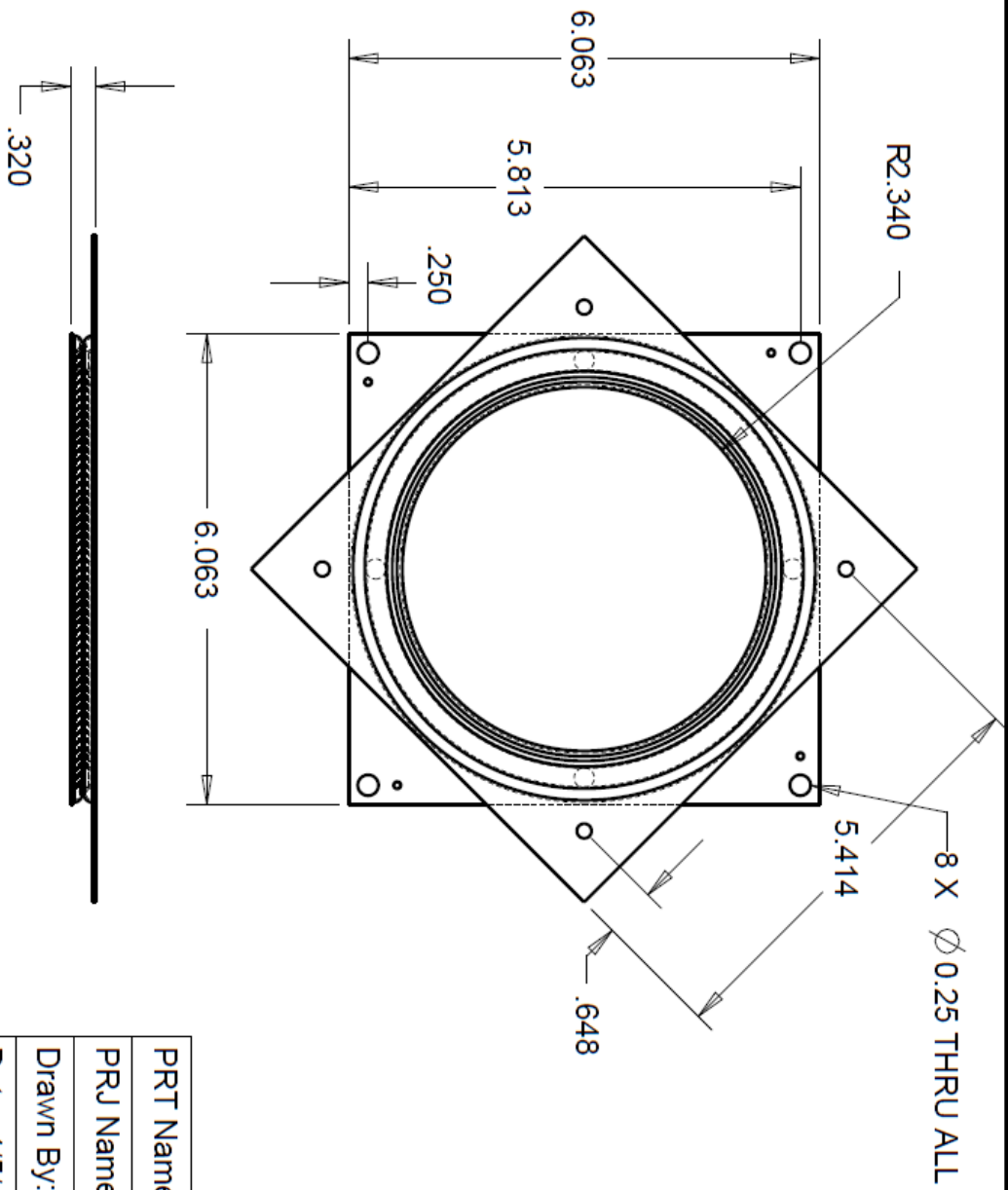

SCALE 0.500

PRT Name: TURNN TABLE	
PRJ Name: C-CATS	
Drawn By: DEVIN SWANSON	
Date: 4/5/12	
REV #: A	Sheet: 4 of 35
DRW #: SP12-M.E-DRW-03	

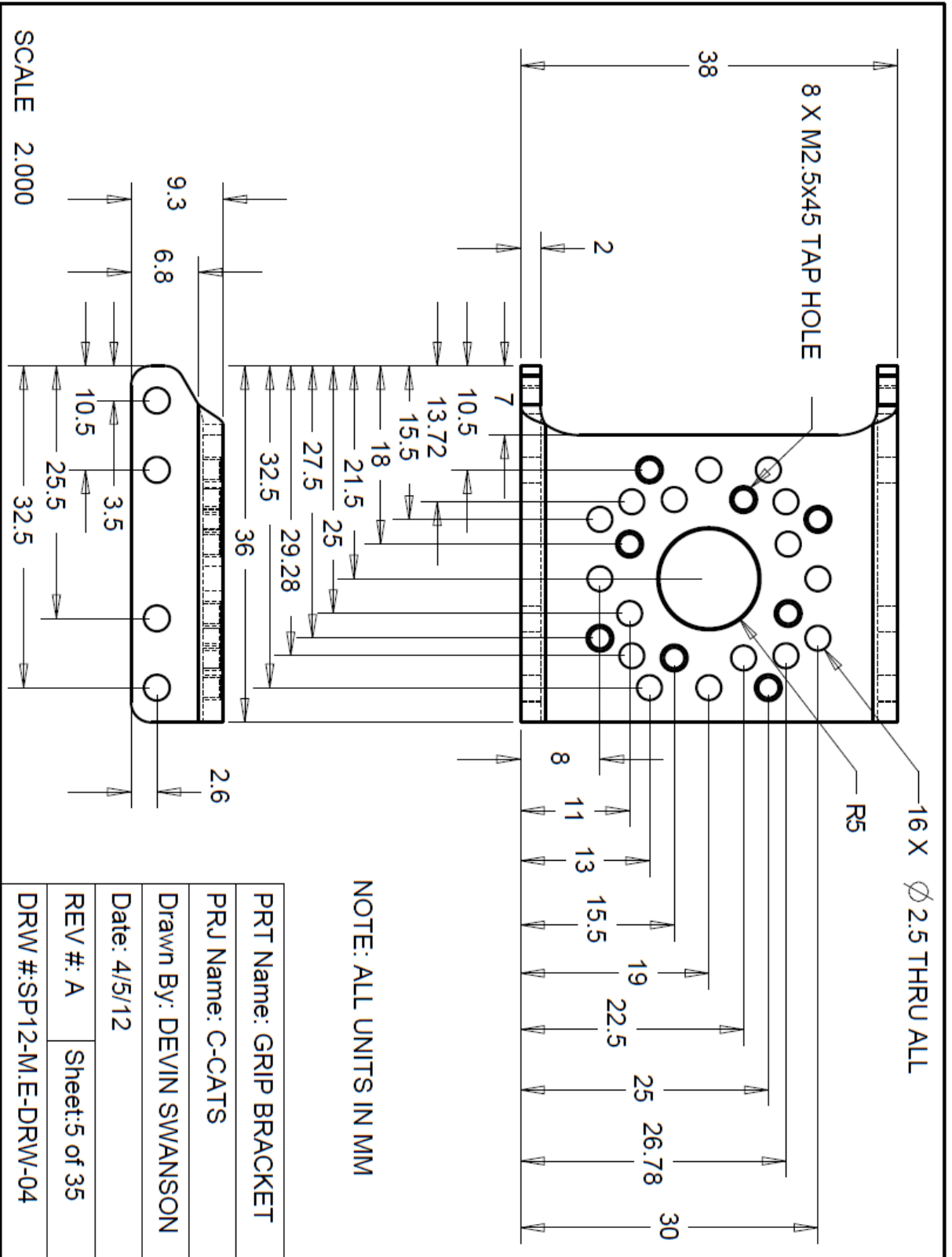

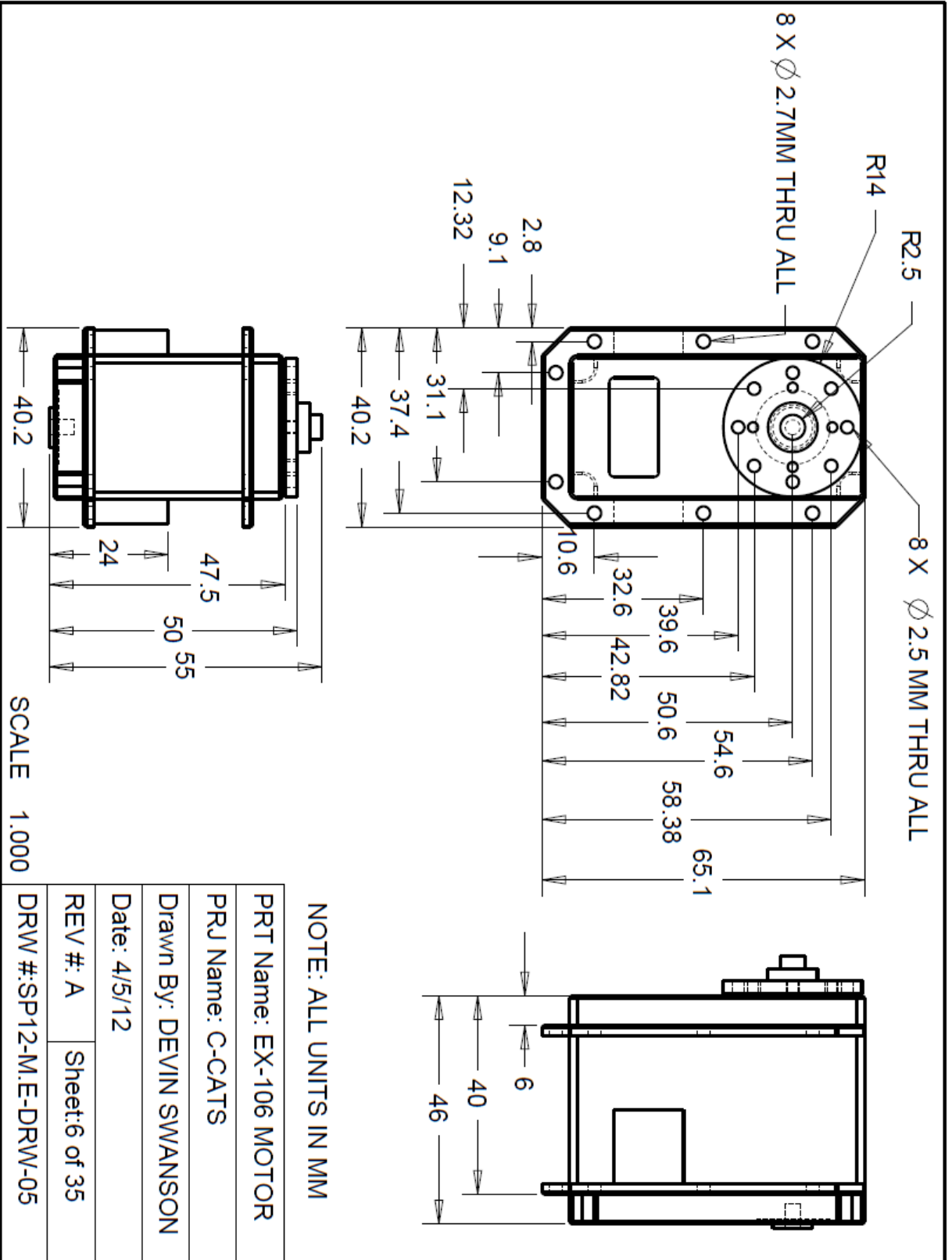

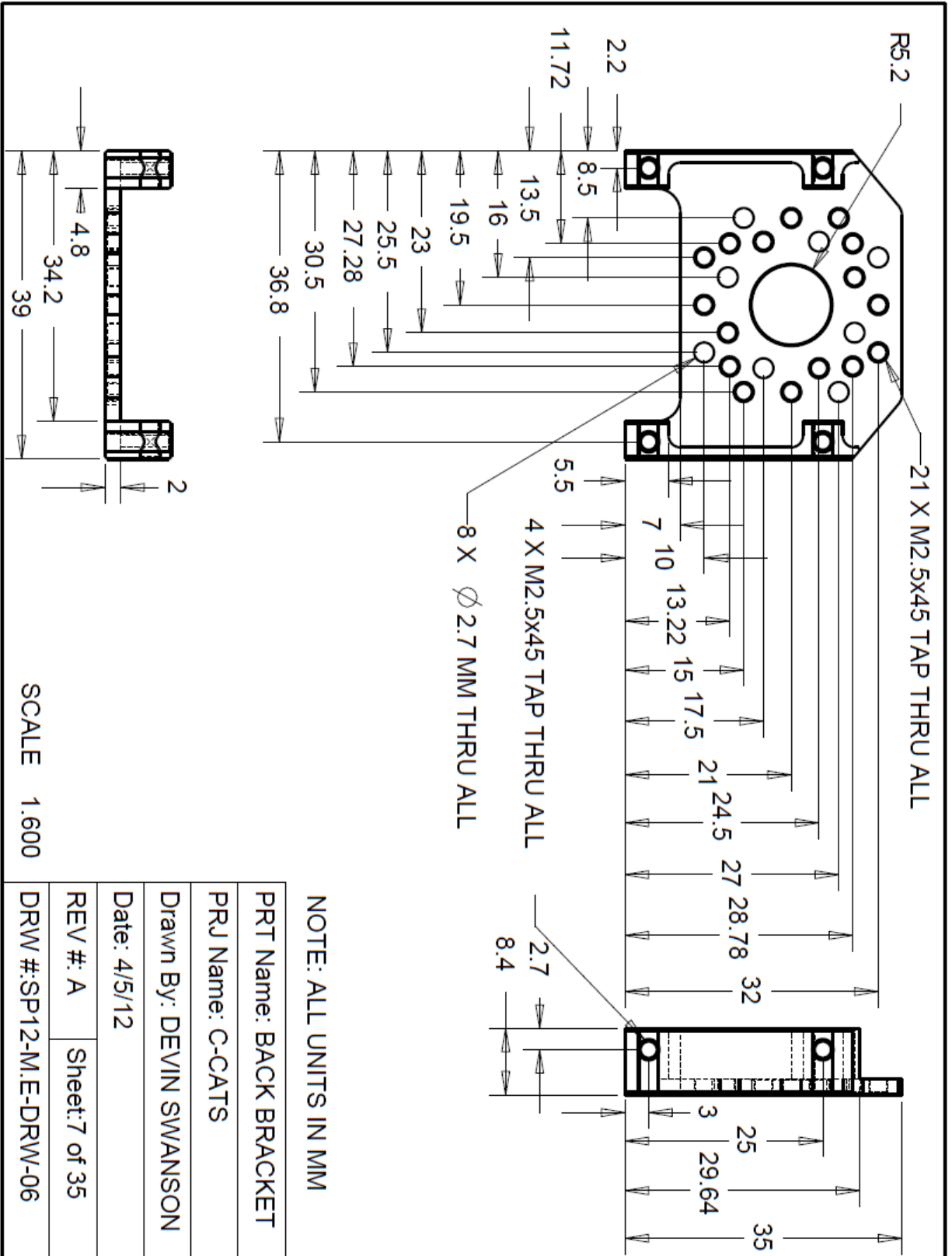

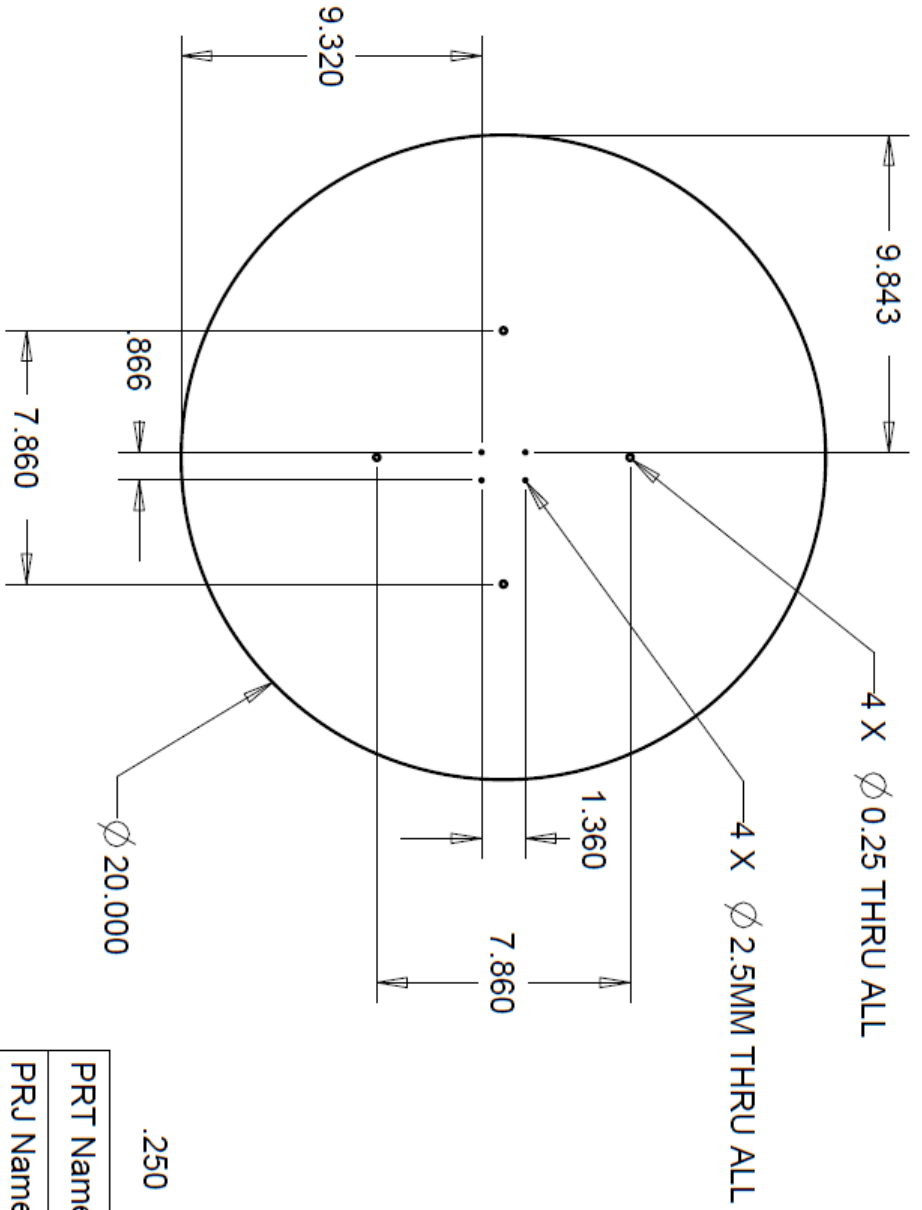

PRT Name: TOP PLATE	
PRJ Name: C-CATS	
Drawn By: DEVIN SWANSON	
Date: 4/5/12	
REV #: A	Sheet: 8 of 35
DRW #: SP12-M.E-DRW-07	

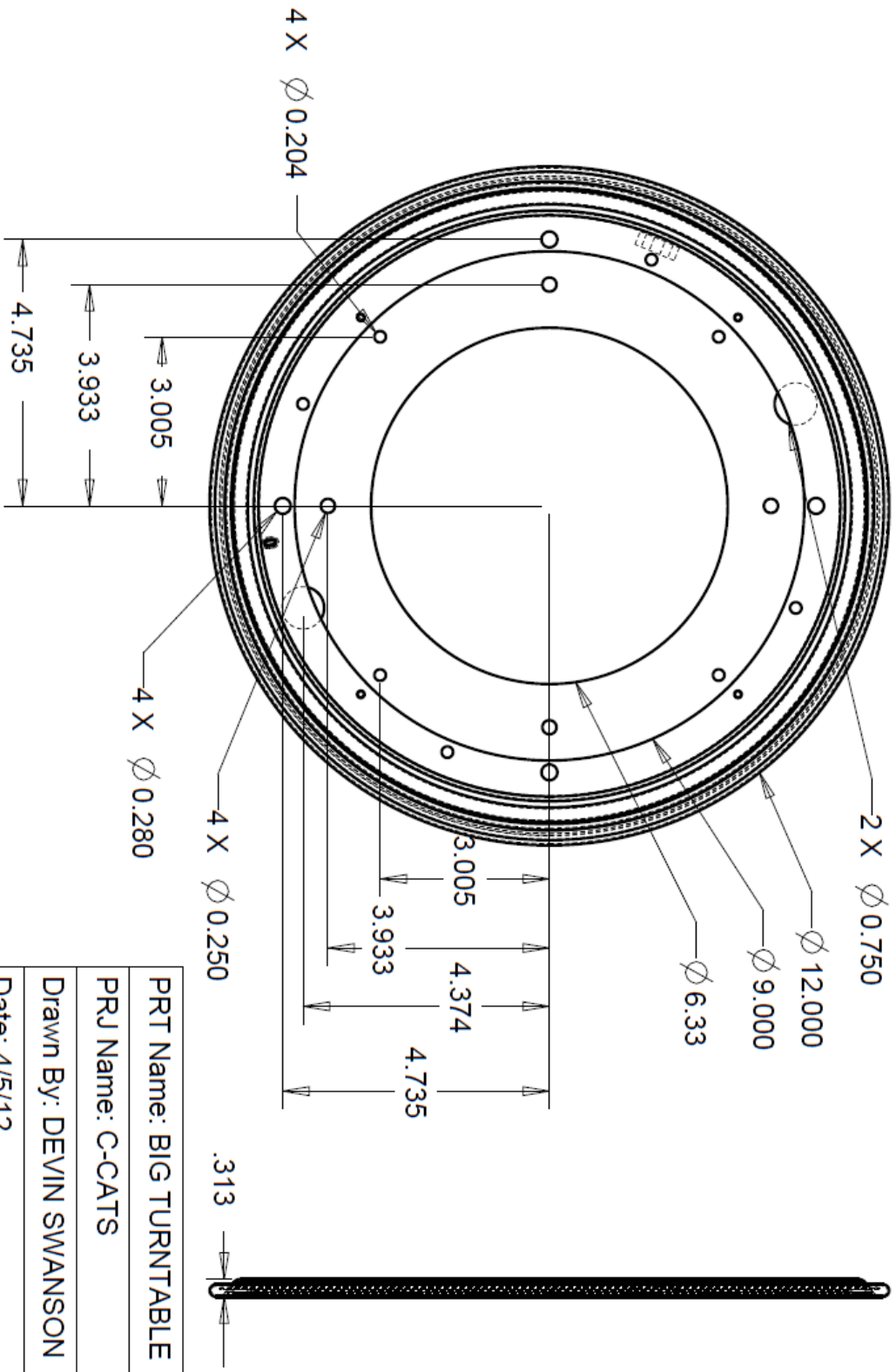

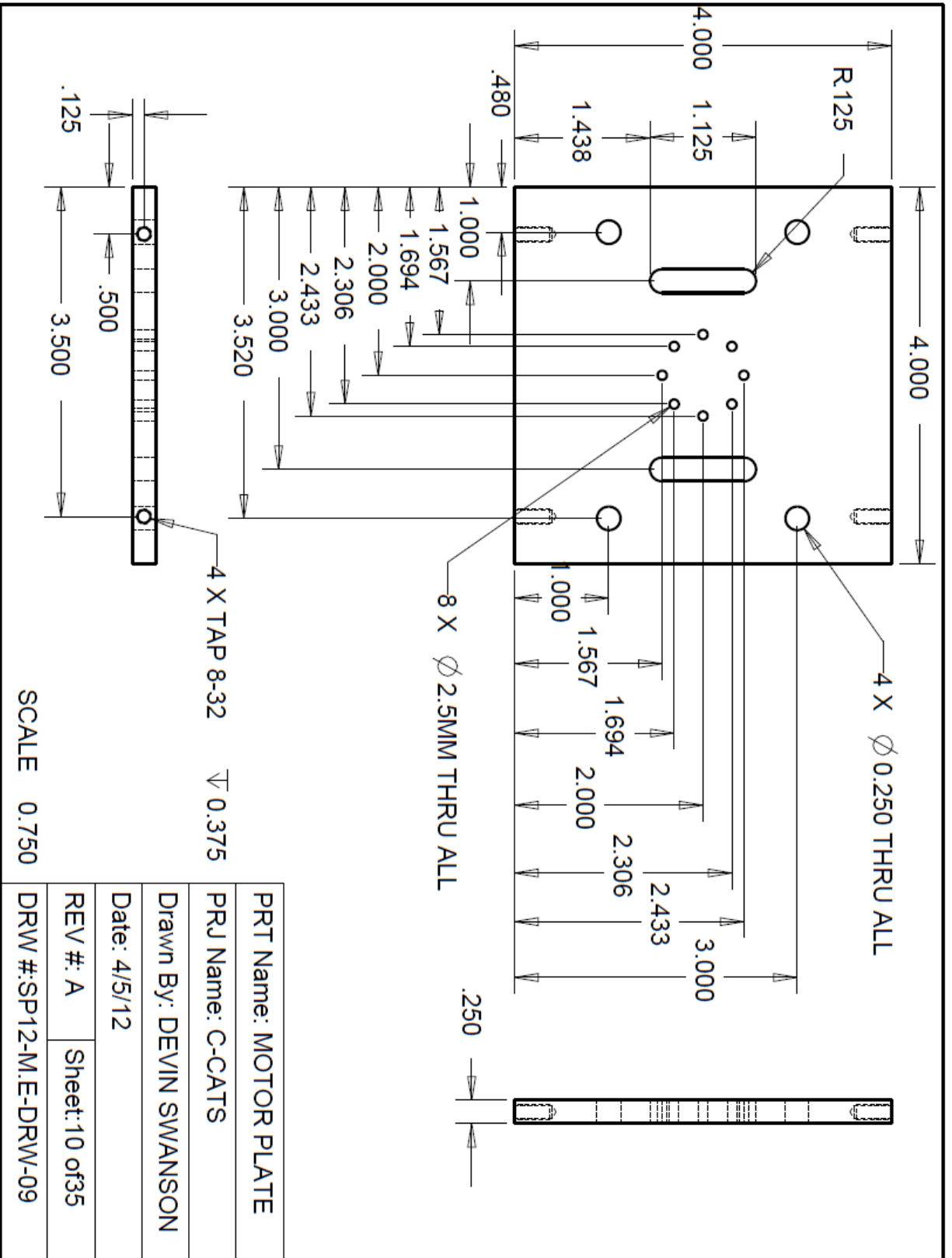



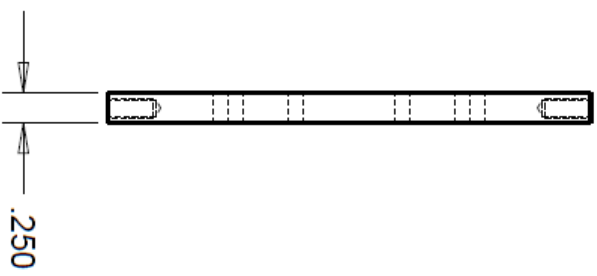
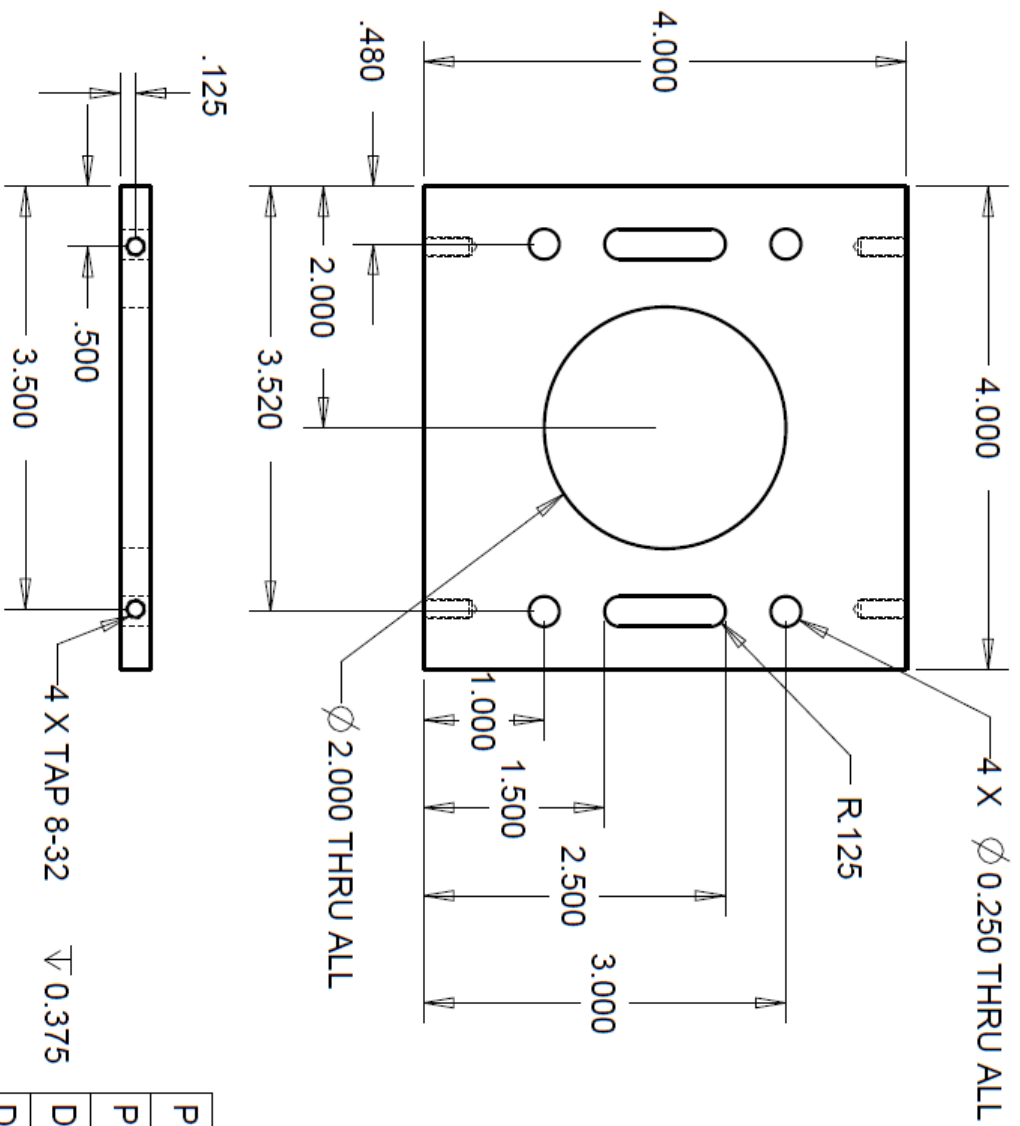

SCALE 0.750

PRT Name: SUPPORT PLATE	
PRJ Name: C-CATS	
Drawn By: DEVIN SWANSON	
Date: 4/5/12	
REV #: A	Sheet: 11 of 35
DRW #: SP12-M.E-DRW-10	

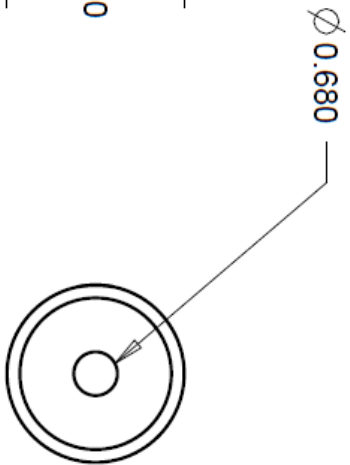
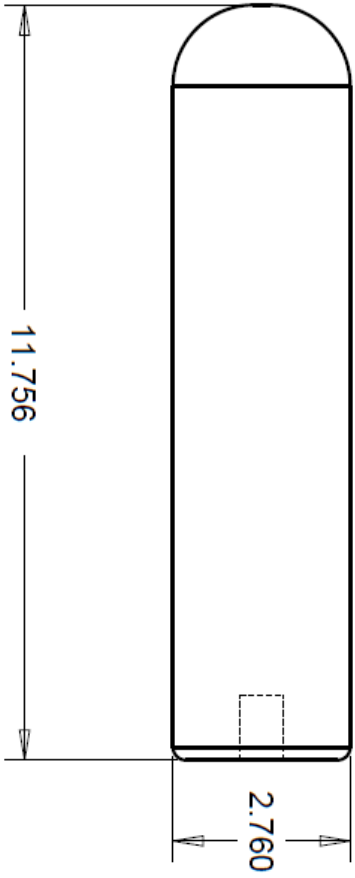

SCALE 0.400

PRT Name: QLOADER	
PRJ Name: C-CATS	
Drawn By: DEVIN SWANSON	
Date: 4/5/12	
REV #: A	Sheet: 12 of 35
DRW #: SP12-M.E-DRW-11	

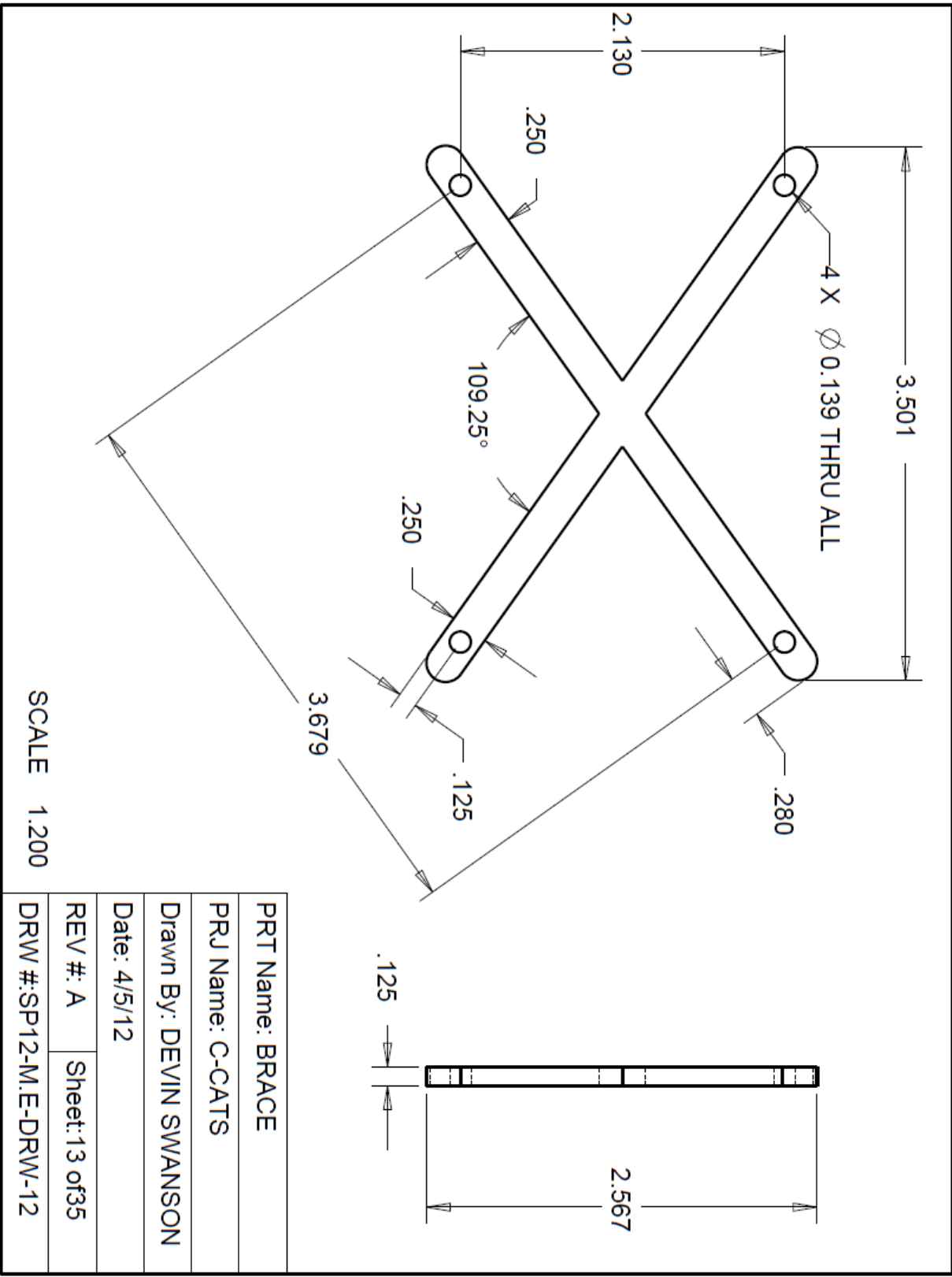

SCALE 1.200

PRT Name: BRACE	
PRJ Name: C-CATS	
Drawn By: DEVIN SWANSON	
Date: 4/5/12	
REV #: A	Sheet: 13 of 35
DRW #: SP12-M.E-DRW-12	

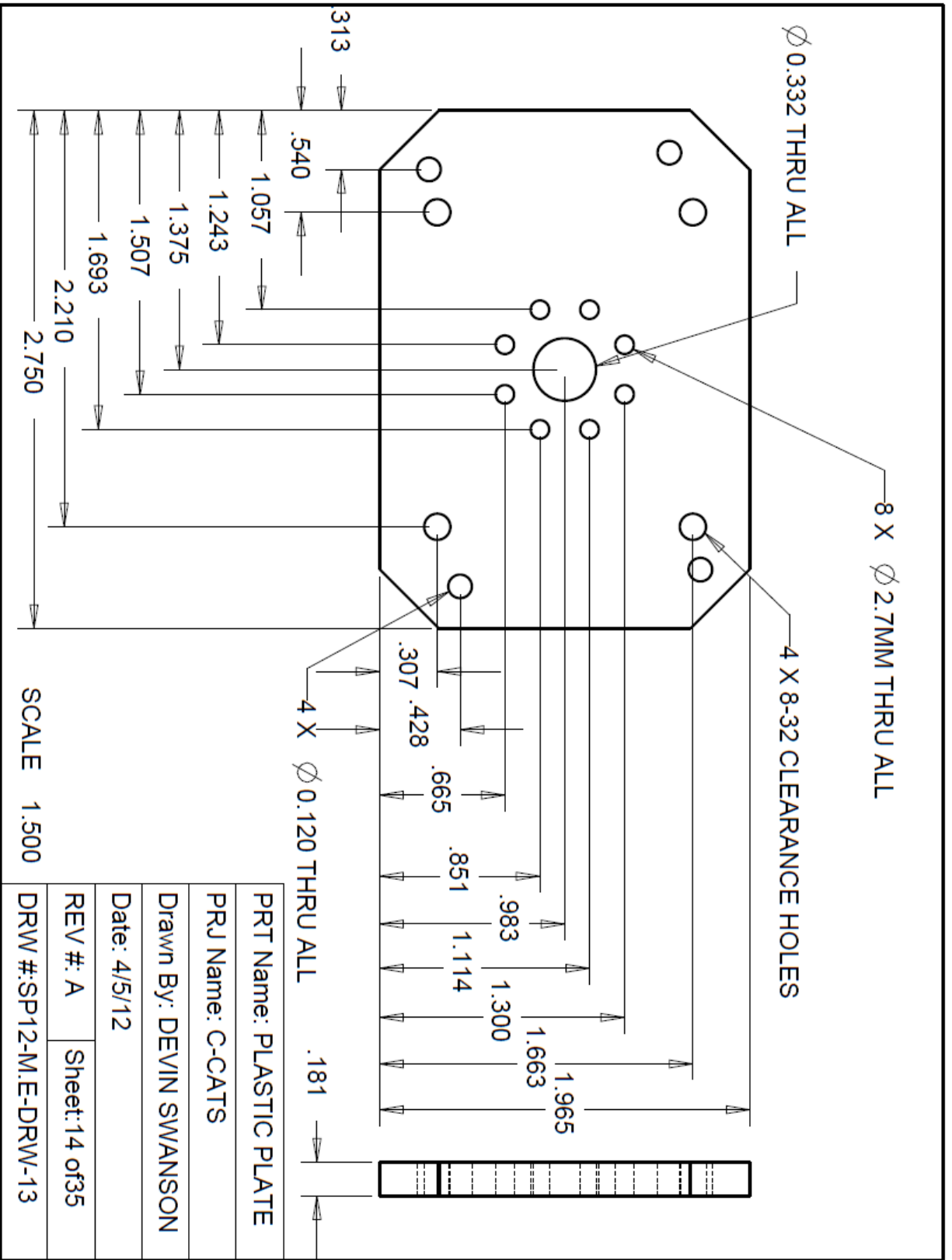

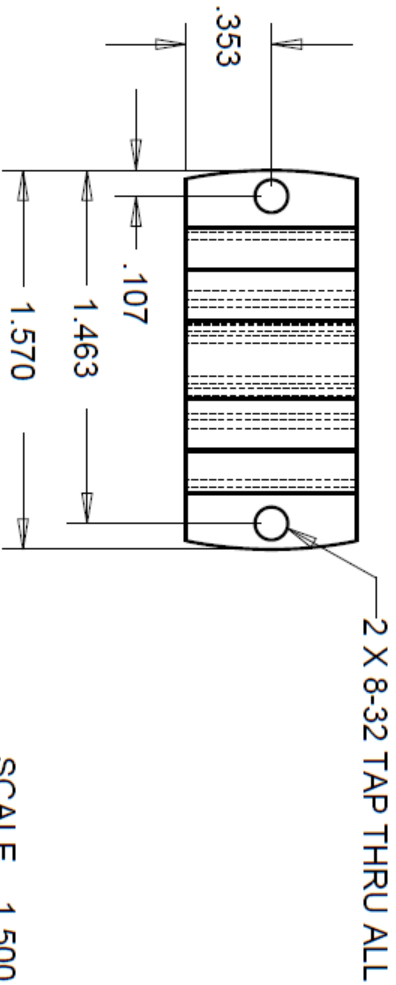
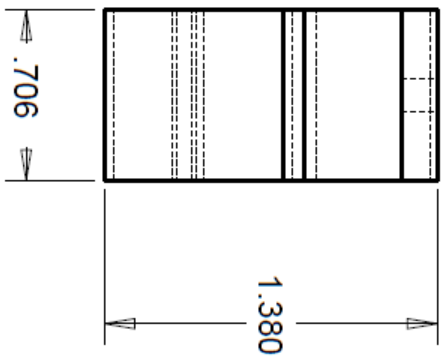
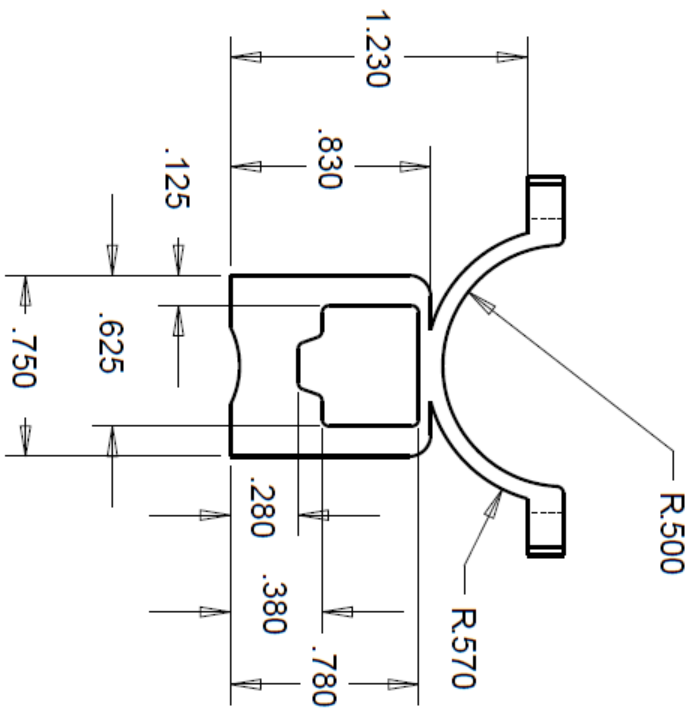

SCALE 1.500

PRT Name: GUN MOUNT	
PRJ Name: C-CATS	
Drawn By: DEVIN SWANSON	
Date: 4/5/12	
REV #: A	Sheet: 15 of 35
DRW #: SP12-M.E-DRW-14	

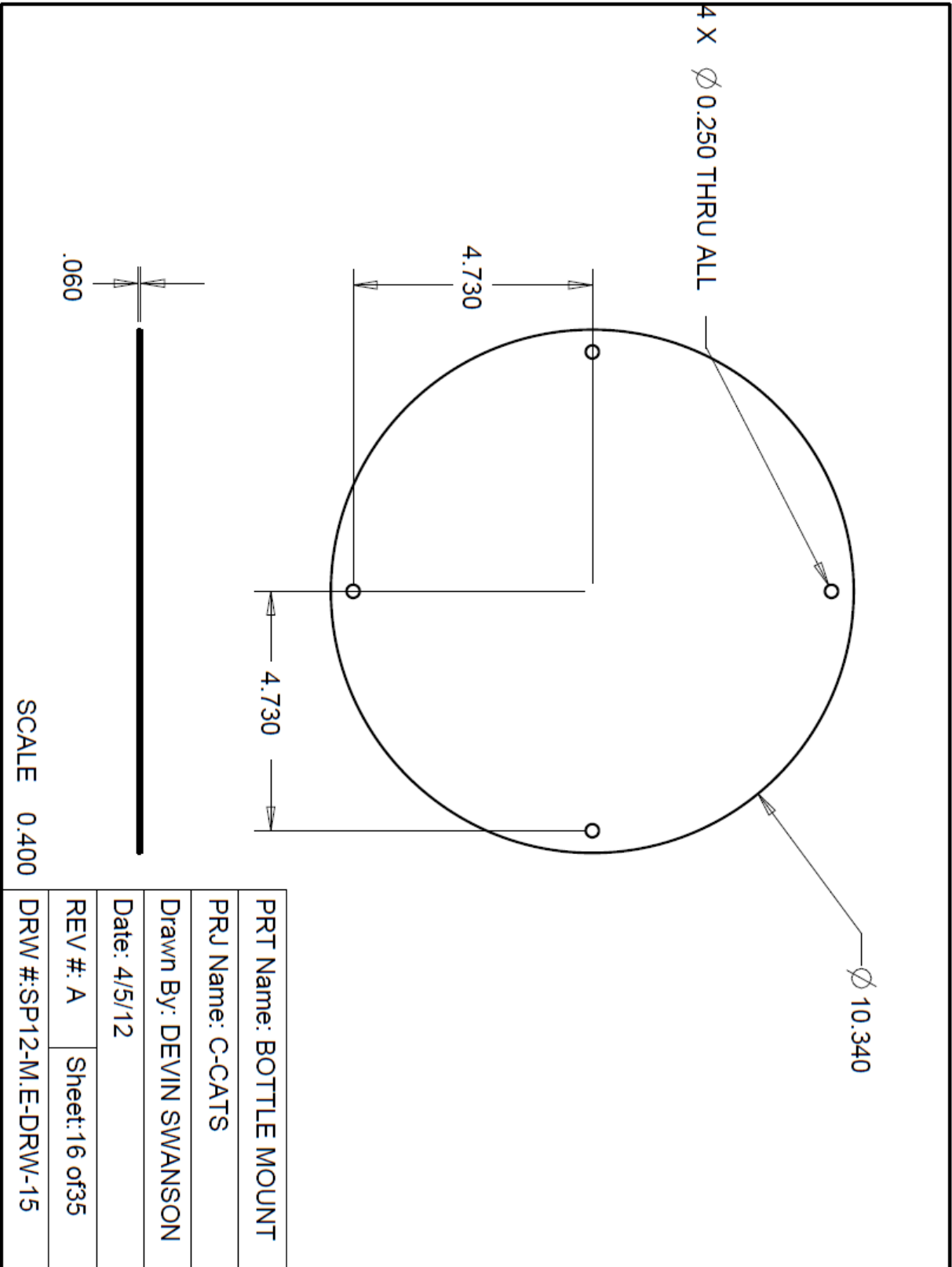

PRT Name: BOTTLE MOUNT	
PRJ Name: C-CATS	
Drawn By: DEVIN SWANSON	
Date: 4/5/12	
REV #: A	Sheet: 16 of 35
DRW #: SP12-M.E-DRW-15	

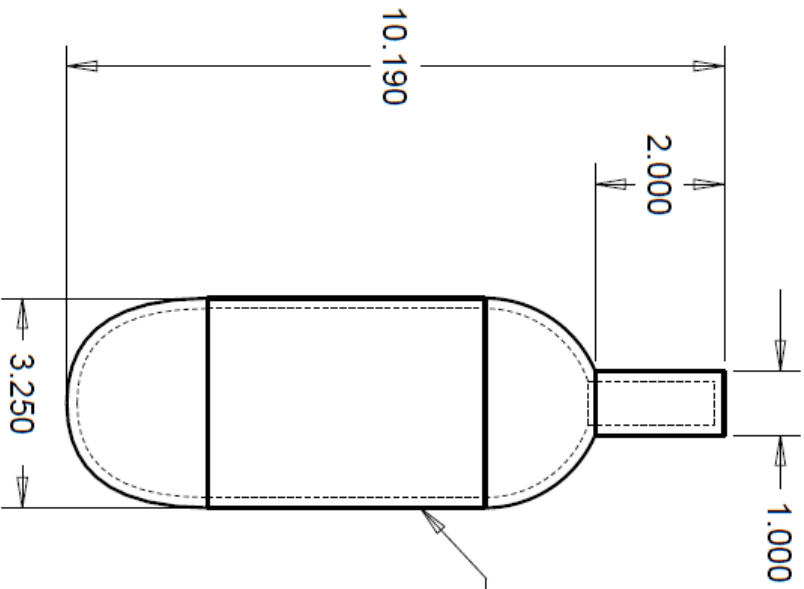
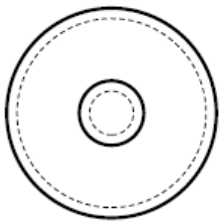

SHELL THICKNESS ~ 0.160

SCALE 0.400

PRT Name: BOTTLE	
PRJ Name: C-CATS	
Drawn By: DEVIN SWANSON	
Date: 4/5/12	
REV #: A	Sheet: 17 of 35
DRW #: SP12-M.E-DRW-16	

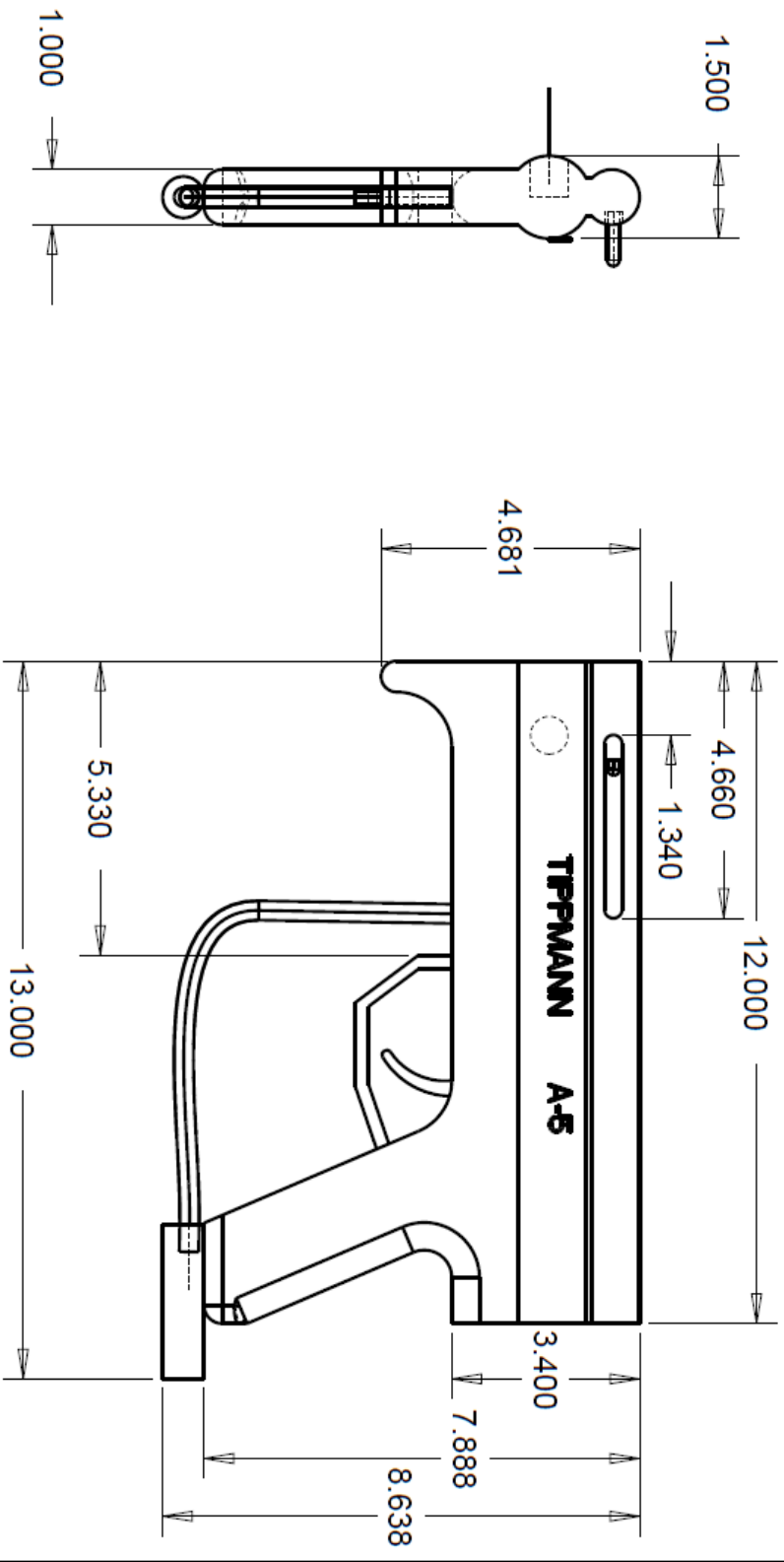

SCALE 0.350

PRT Name: TIPPMANN A-5	
PRJ Name: C-CATS	
Drawn By: DEVIN SWANSON	
Date: 4/5/12	
REV #: A	Sheet: 18 of 35
DRW #: SP12-M.E-DRW-17	



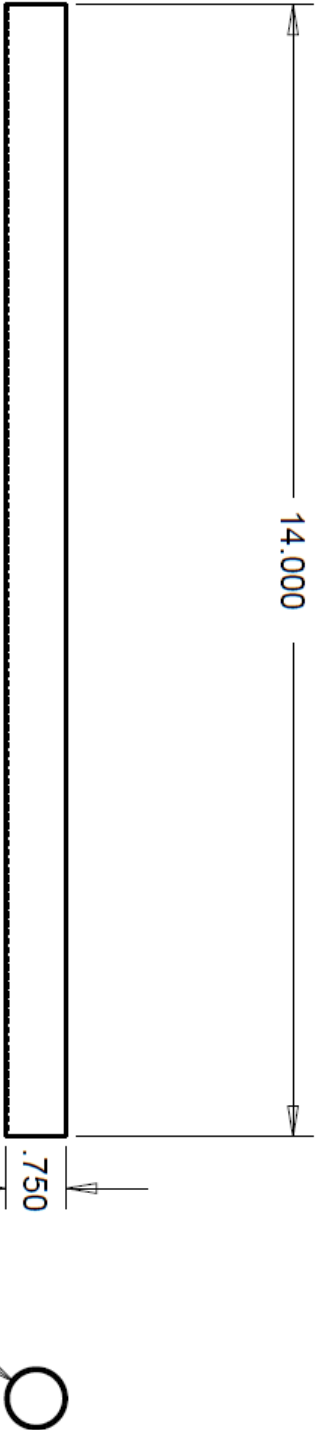

PRT Name: 14" BARREL	
PRJ Name: C-CATS	
Drawn By: DEVIN SWANSON	
Date: 4/5/12	
REV #: A	Sheet: 19 of 35
DRW #: SP12-M.E-DRW-18	

SCALE 0.500

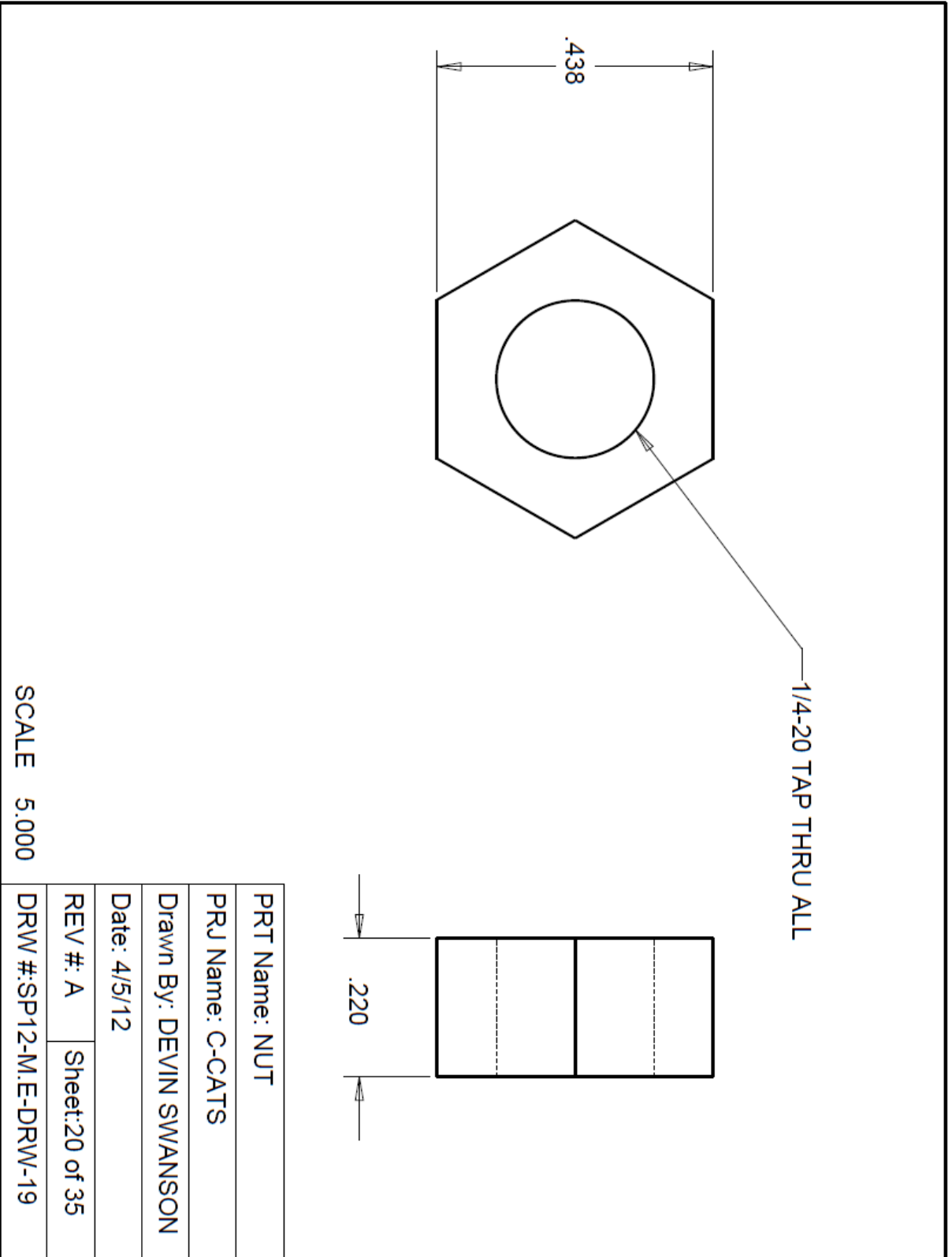

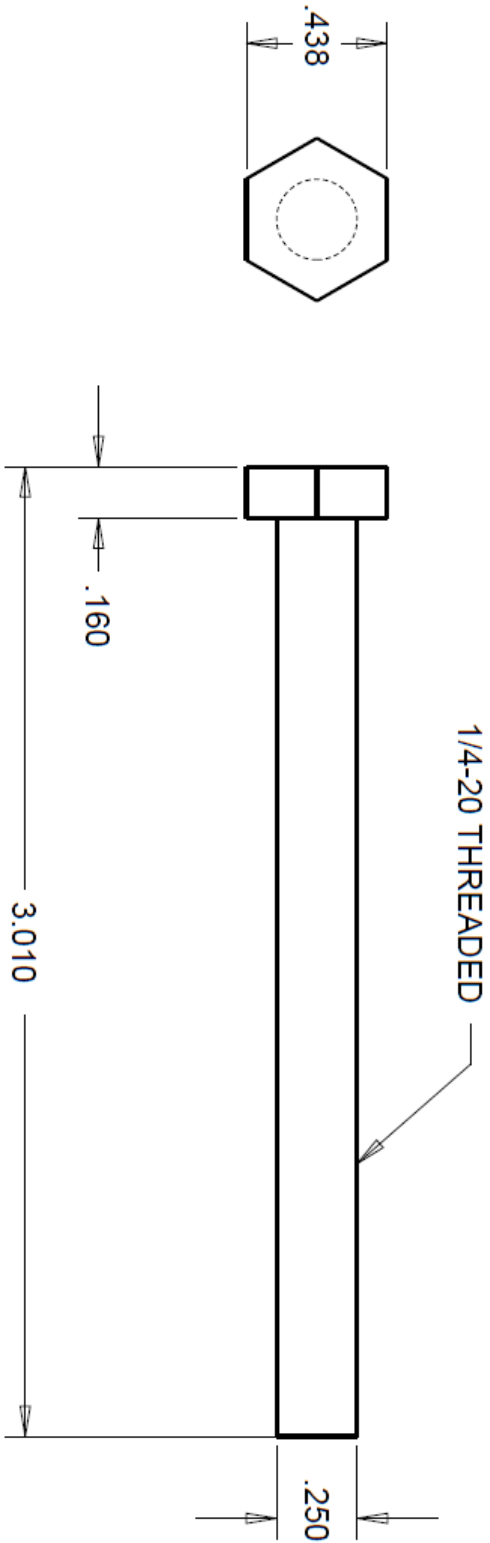

SCALE 2.000

PRT Name: TURNTABLE BOLT	
PRJ Name: C-CATS	
Drawn By: DEVIN SWANSON	
Date: 4/5/12	
REV #: A	Sheet: 21 of 35
DRW #: SP12-M.E-DRW-20	

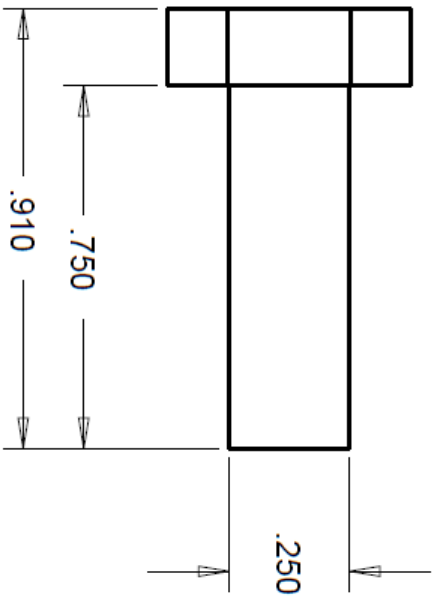
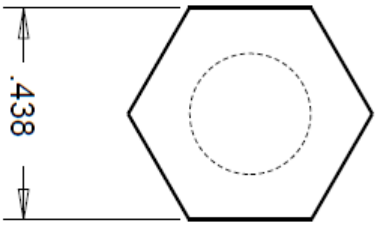

PRT Name: SMALL BOLT	
PRJ Name: C-CATS	
Drawn By: DEVIN SWANSON	
Date: 4/5/12	
REV #: A	Sheet: 22 of 35
DRW #: SP12-M.E-DRW-21	

SCALE 3.000

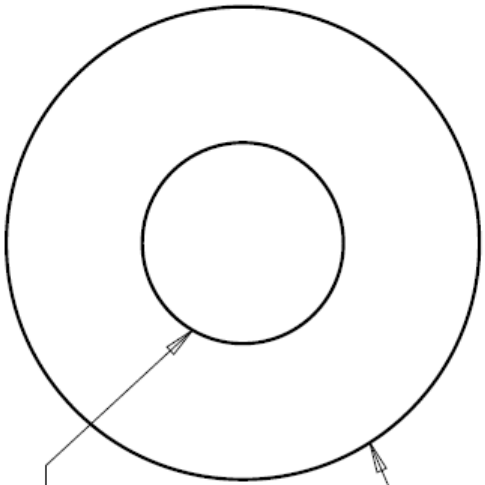

$\varnothing$  0.320

$\varnothing$  0.740

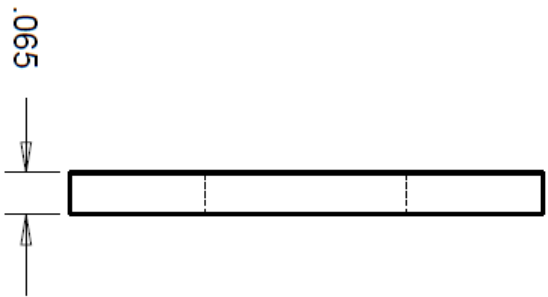

.065

SCALE 4.000

PRT Name: WASHER	
PRJ Name: C-CATS	
Drawn By: DEVIN SWANSON	
Date: 4/5/12	
REV #: A	Sheet: 23 of 35
DRW #: SP12-M.E-DRW-22	

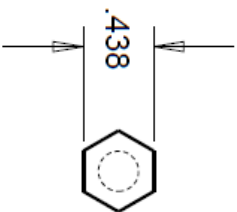
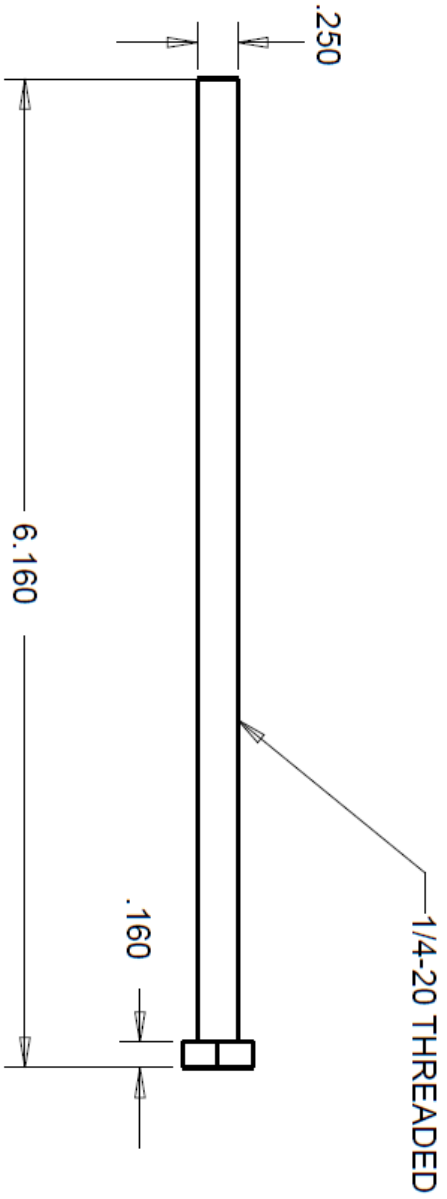

SCALE 1.000

PRT Name: LONG BOLT	
PRJ Name: C-CATS	
Drawn By: DEVIN SWANSON	
Date: 4/5/12	
REV #: A	Sheet: 24 of 35
DRW #: SP12-M.E-DRW-23	

M2.5x45 THREADED

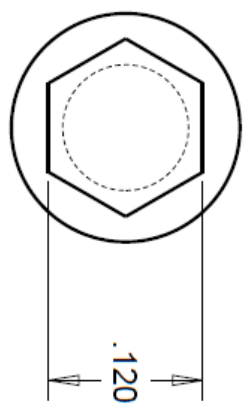
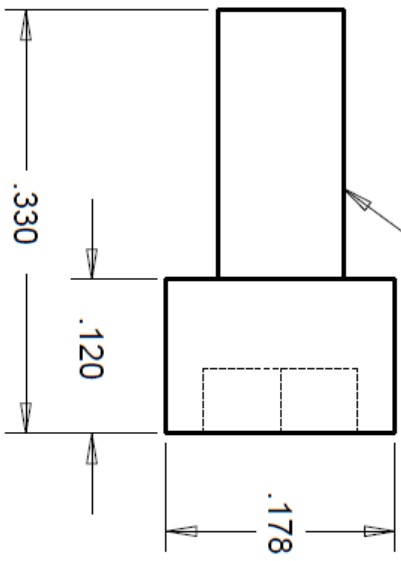

SCALE 8.000

PRT Name: BRACKET SCREW	
PRJ Name: C-CATS	
Drawn By: DEVIN SWANSON	
Date: 4/5/12	
REV #: A	Sheet: 25 of 35
DRW #: SP12-M.E-DRW-24	

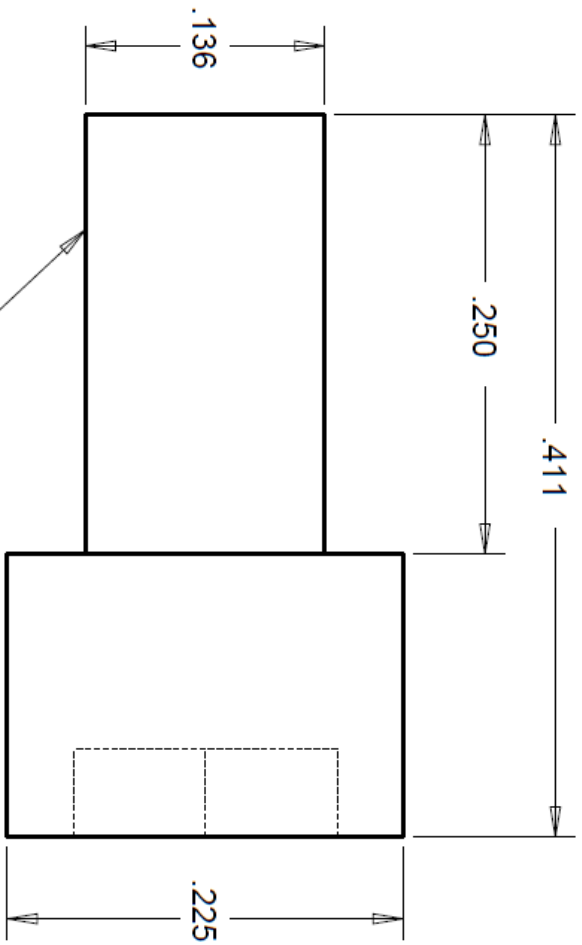

THREADED 8-32

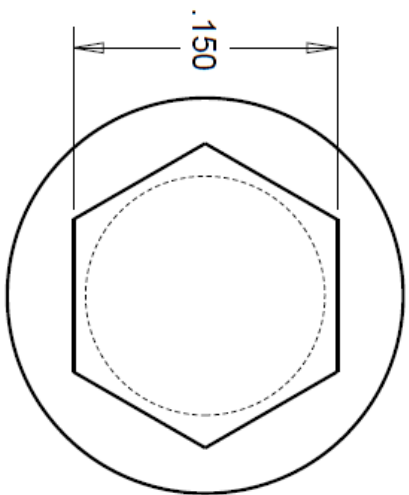

PRT Name: 8-32 SCREW	
PRJ Name: C-CATS	
Drawn By: DEVIN SWANSON	
Date: 4/5/12	
REV #: A	Sheet: 26 of 35
DRW #: SP12-M.E-DRW-25	



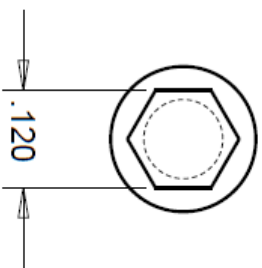
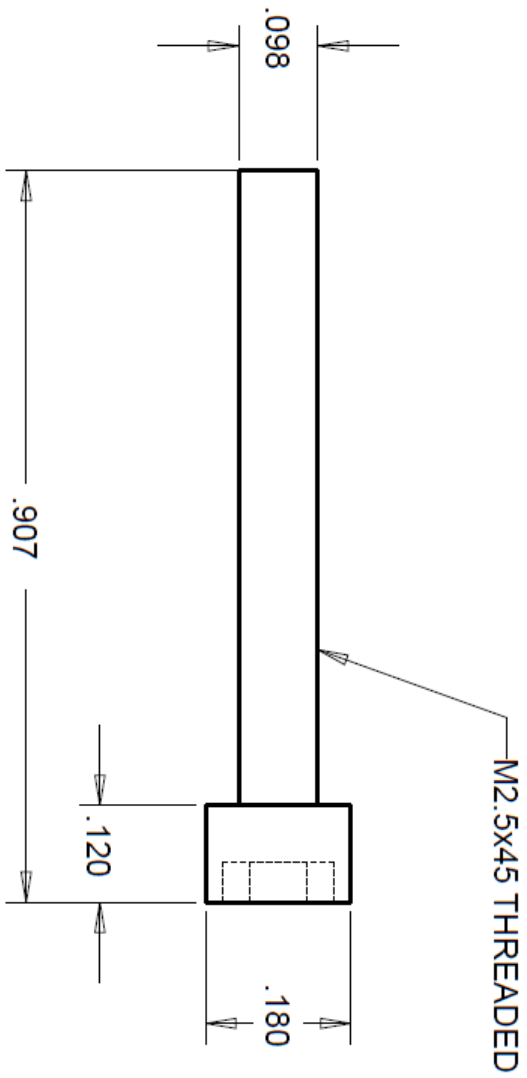

SCALE 5.000

PRT Name: LONG SCREW	
PRJ Name: C-CATS	
Drawn By: DEVIN SWANSON	
Date: 4/5/12	
REV #: A	Sheet: 27 of 35
DRW #: SP12-M.E-DRW-26	

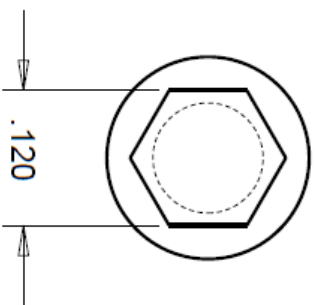
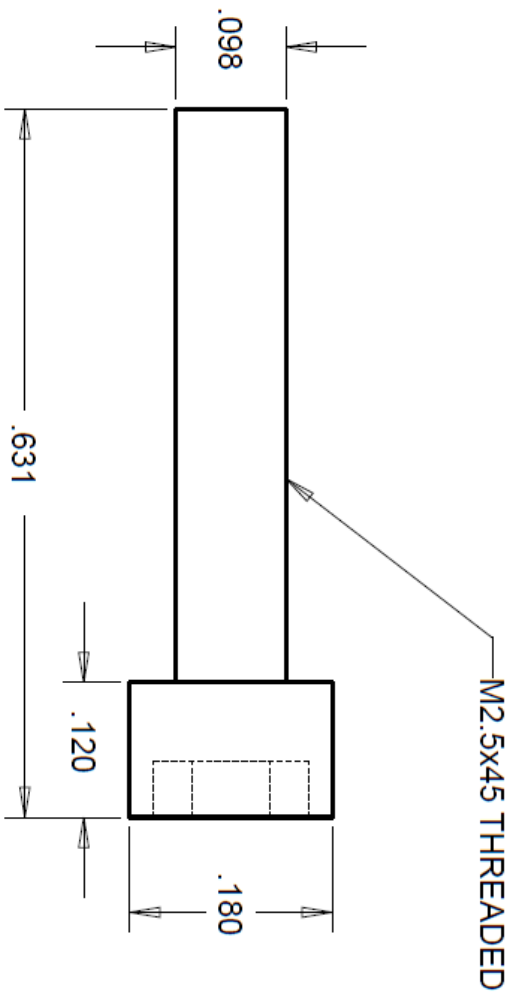

SCALE 7.000

PRT Name: M2.5 X 13MM	
PRJ Name: C-CATS	
Drawn By: DEVIN SWANSON	
Date: 4/5/12	
REV #: A	Sheet: 28 of 35
DRW #: SP12-M.E-DRW-27	

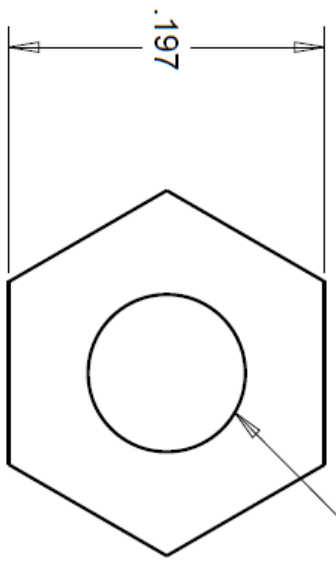

M2.5X45 TAP THRU ALL

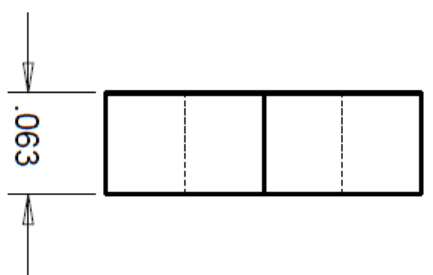

SCALE 10.000

PRT Name: SMALL NUT	
PRJ Name: C-CATS	
Drawn By: DEVIN SWANSON	
Date: 4/5/12	
REV #: A	Sheet: 29 of 35
DRW #: SP12-M.E-DRW-28	

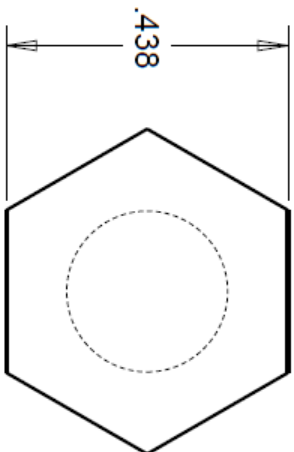
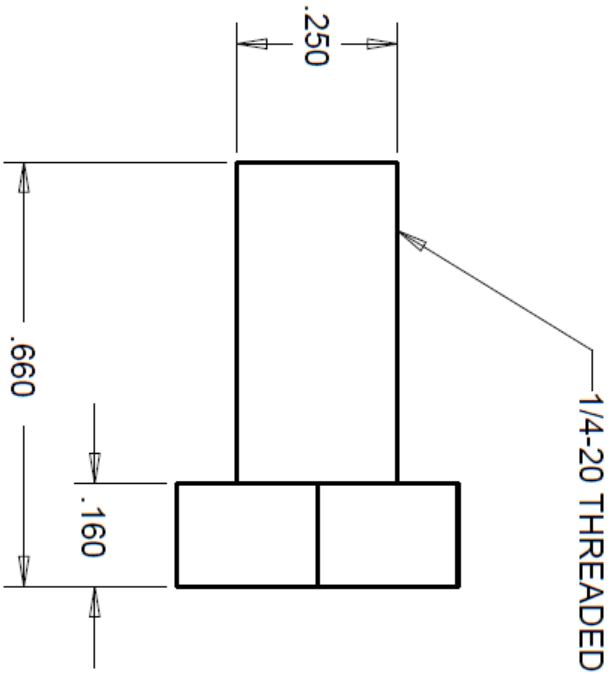

SCALE 4.000

PRT Name: 1/2" BOLT	
PRJ Name: C-CATS	
Drawn By: DEVIN SWANSON	
Date: 4/5/12	
REV #: A	Sheet: 30 of 35
DRW #: SP12-M.E-DRW-29	

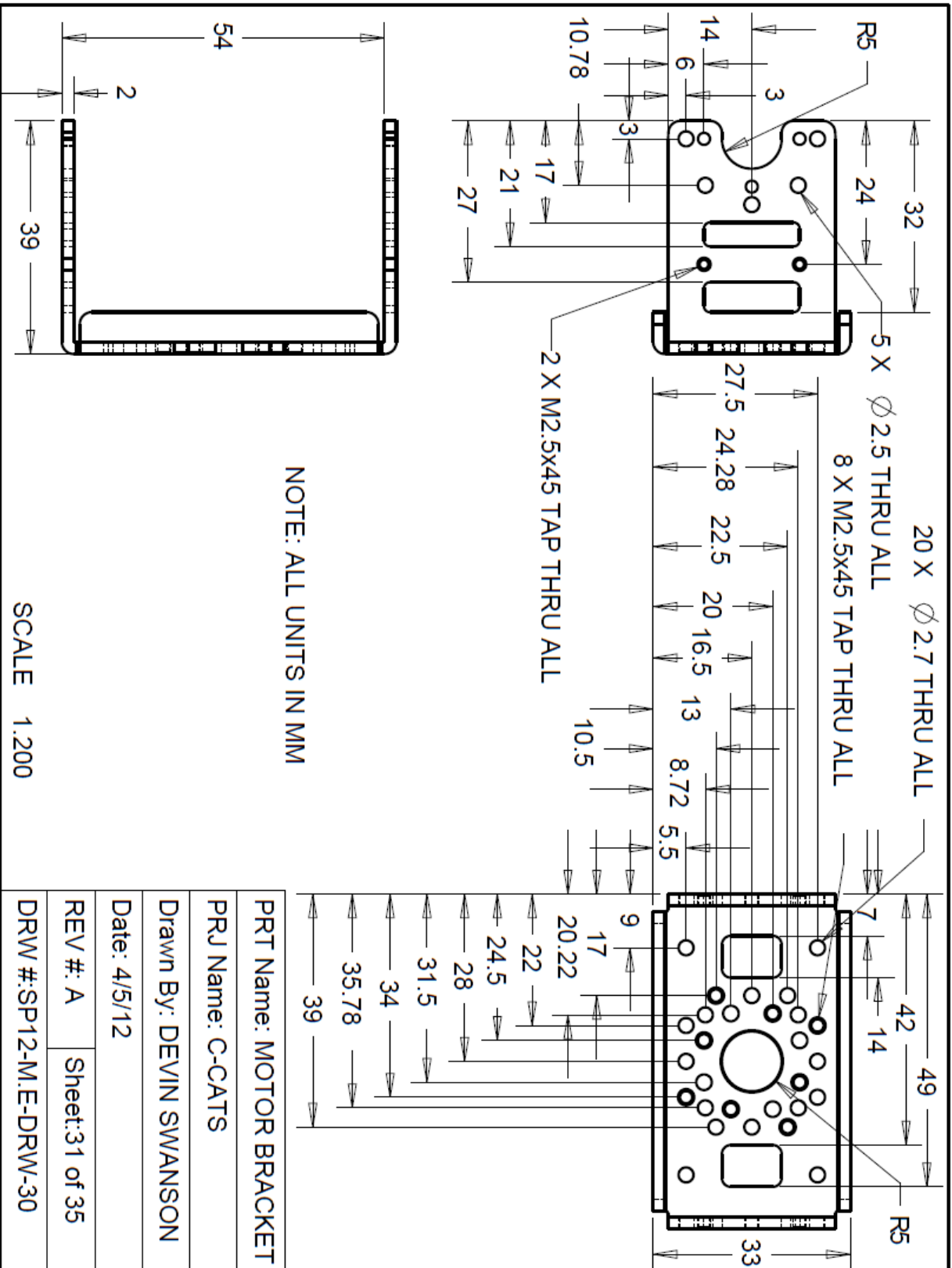

PRT Name: MOTOR BRACKET	
PRJ Name: C-CATS	
Drawn By: DEVIN SWANSON	
Date: 4/5/12	
REV #: A	Sheet: 31 of 35
DRW #: SP12-M.E-DRW-30	

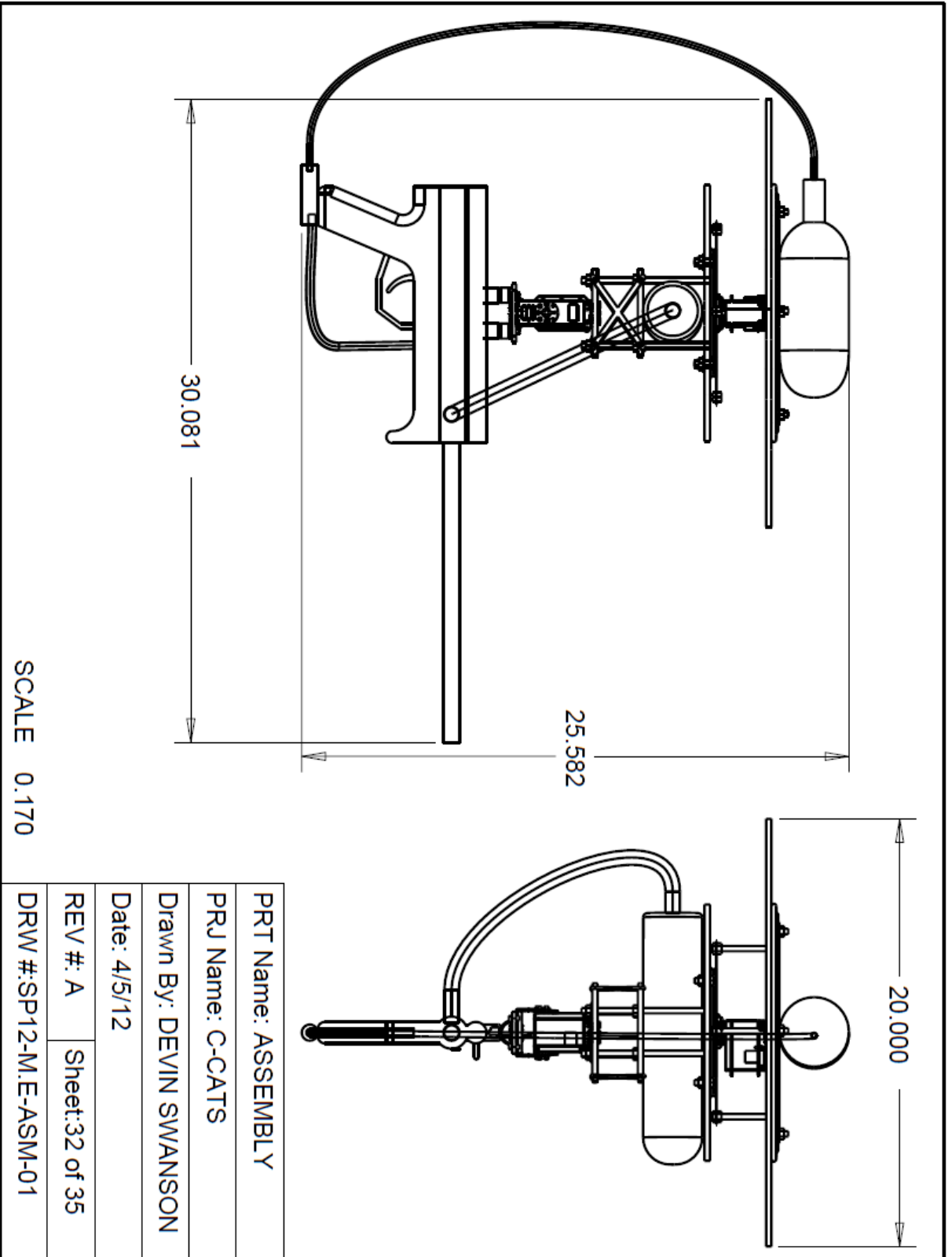

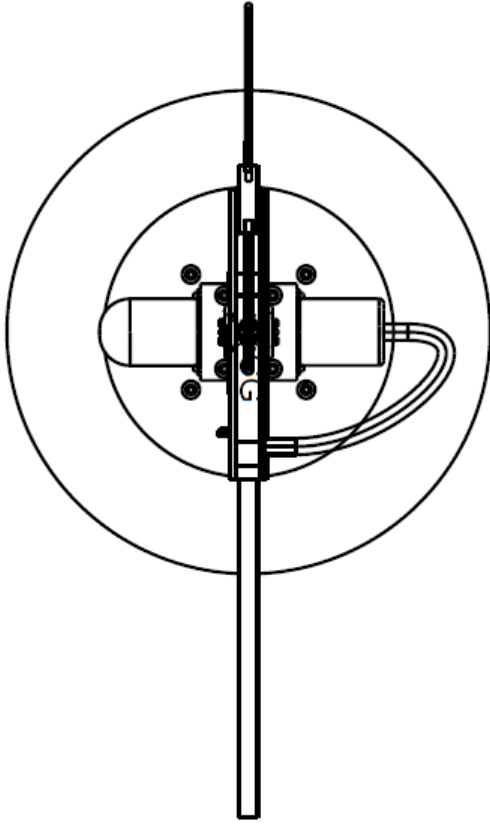
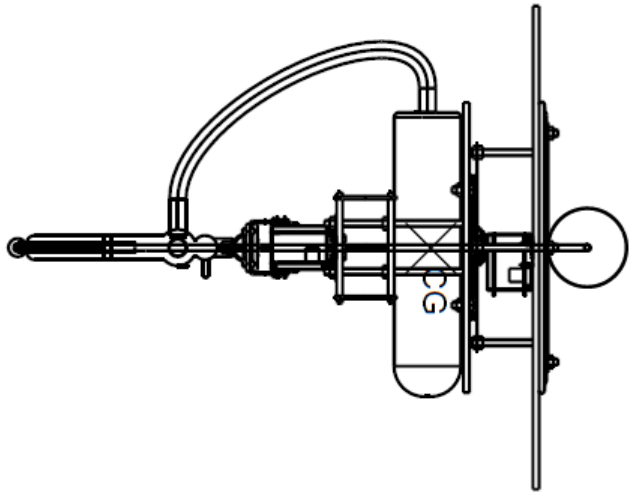
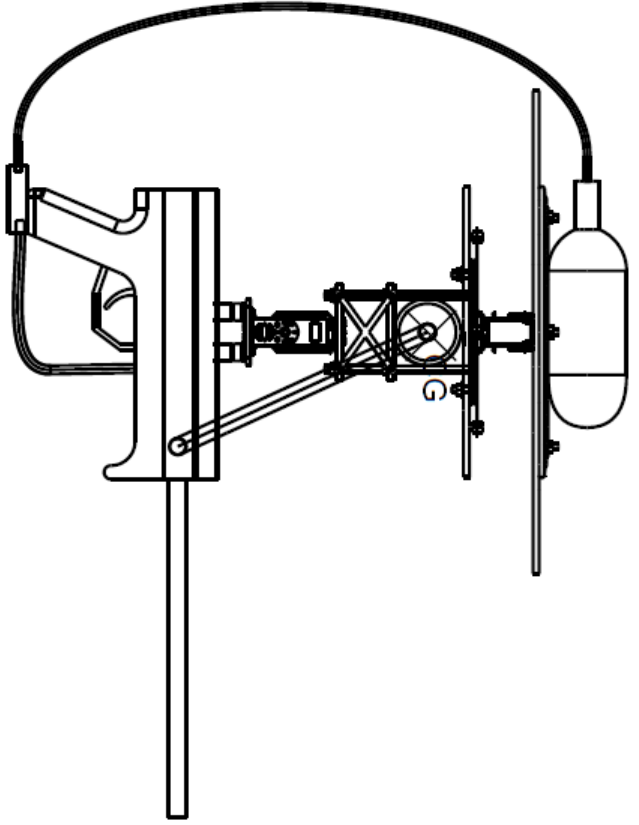

SCALE 0.150

PRT Name: ASSEMBLY C.G	
PRJ Name: C-CATS	
Drawn By: DEVIN SWANSON	
Date: 4/5/12	
REV #: A	Sheet: 33 of 35
DRW #: SP12-M.E-ASM-02	

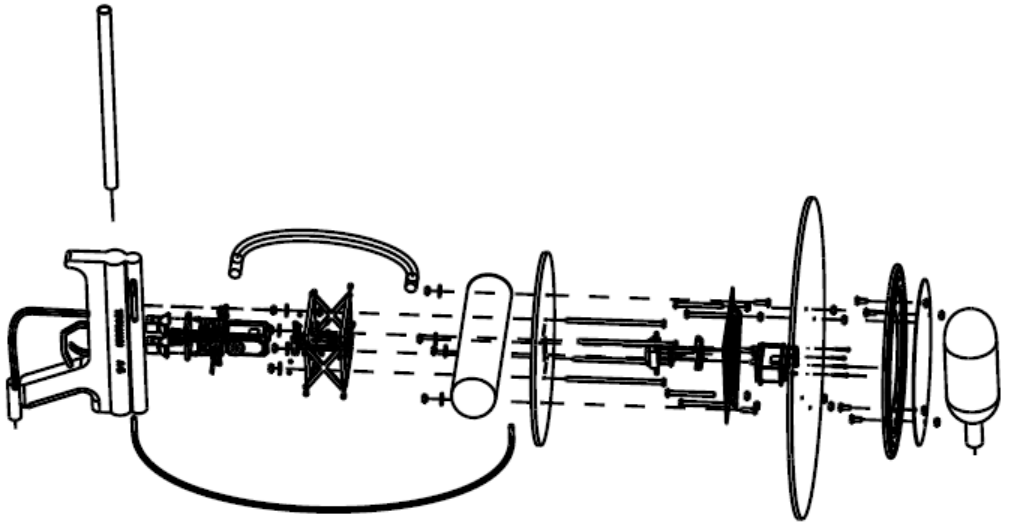

SCALE 0.100

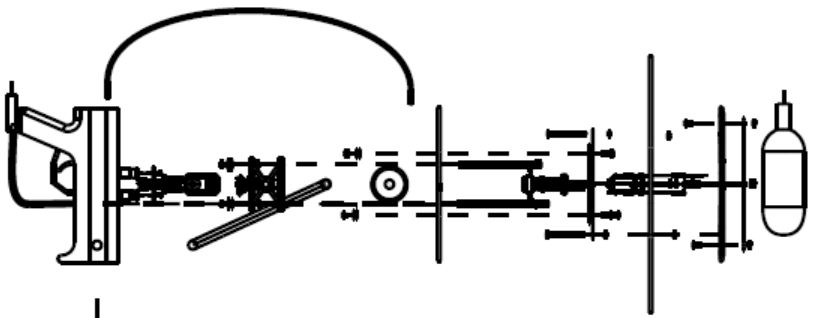

SCALE 0.080

PRT Name: EXPL0DE	
PRJ Name: C-CATS	
Drawn By: DEVIN SWANSON	
Date: 4/5/12	
REV #: A	Sheet: 34 of 35
DRW #: SP12-M.E-EXP-01	



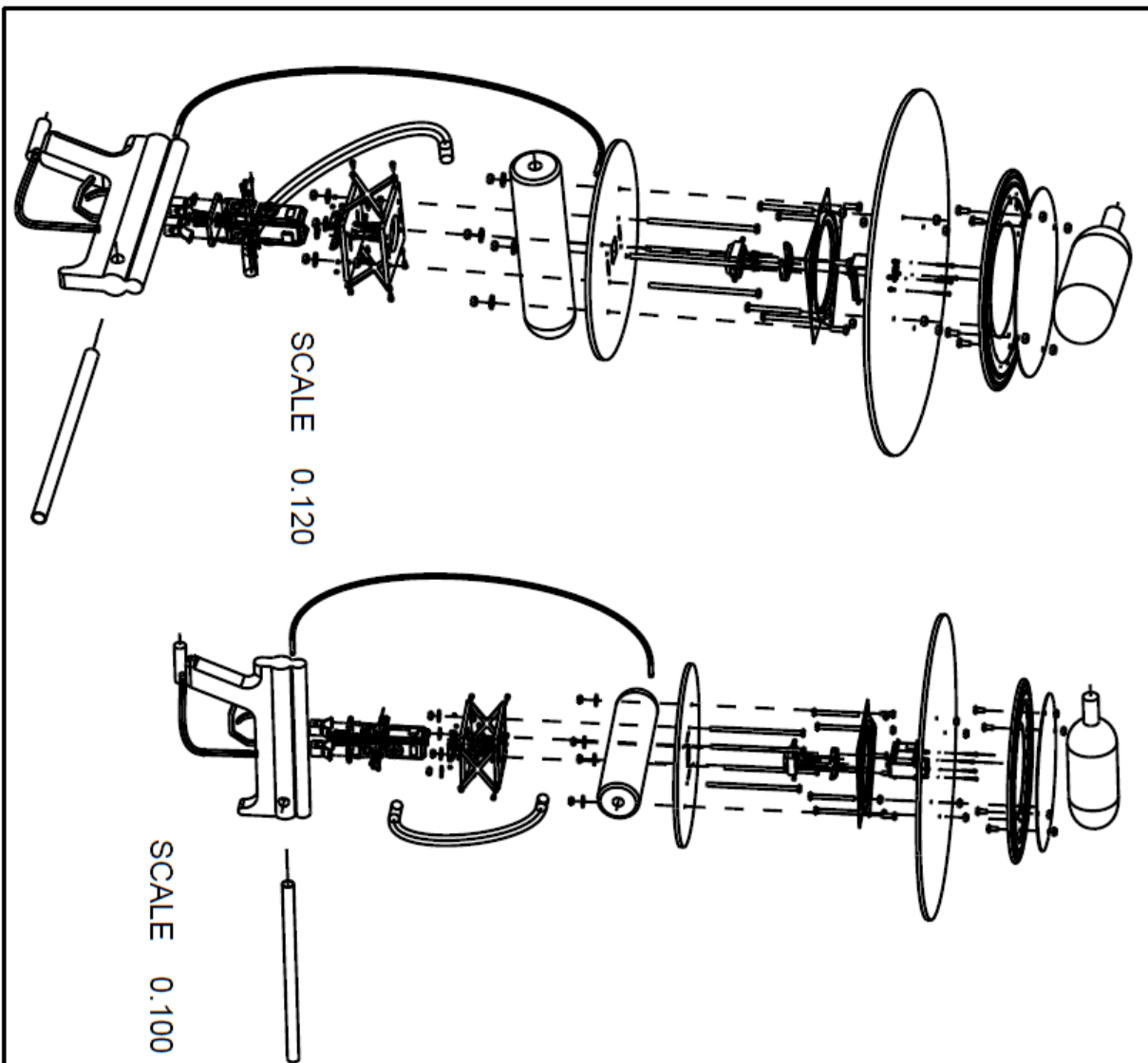

PRT Name: EXPLODE 2	
PRJ Name: C-CATS	
Drawn By: DEVIN SWANSON	
Date: 4/5/12	
REV #: A	Sheet: 35 of 35
DRW #: SP12-M.E-EXP-02	

## References

"Dynamixel Series Servos." *Trossen Robotics*. Web. 29 Mar. 2012.

<<http://www.trossenrobotics.com/c/robotis-dynamixel-robot-servos.aspx>>.

Hyman, Barry I. *Fundamentals of Engineering Design*. Second ed. Upper Saddle River, NJ: Prentice Hall/Pearson Education, 2002. Print.

"Loctite Adhesives Products." *Loctite Threadlocker Blue 242 from Loctite Adhesives*.

Web. 29 Mar. 2012.

<[http://www.loctiteproducts.com/p/t\\_lkr\\_blue/overview/Loctite-Threadlocker-Blue-242.htm](http://www.loctiteproducts.com/p/t_lkr_blue/overview/Loctite-Threadlocker-Blue-242.htm)>.

"Mechanical Metallurgy", G. E. Dieter, 3<sup>rd</sup> Edition, McGraw Hill Book Company, 1986

## Biographical Sketch

Alan Delgado:

Broderick Epperson:

Broderick Epperson is a sixth year senior mechanical engineering student at Florida Agriculture Mechanical University from Jacksonville, Florida. While attending Florida A&M University as a pre-engineer major, Broderick was selected for Dean's List numerous times and other academic honors. During his undergraduate career as a mechanical major, he found an increasing interest in fluid mechanics, heat transfer of materials and fluids and propulsion systems (i.e. jets and rockets), which inspired him to seek an internship in the industry of HVAC (heating ventilation air conditioning). After graduation, Broderick Epperson is planning to seek employment in a newly established design and building construction company, and in the future he hopes to branch off and start his personal design build company.

Devin Swanson:

Devin Swanson is from Ponte Vedra Beach, Florida. He has lived in Florida his whole life and has lived in several cities from Key West to Jacksonville and places in between. He graduated from Allen D. Nease high school in Jacksonville where he participated in football, track, and ROTC. After high school he went to Embry Riddle Aeronautical University in Daytona Beach, FL. There he did ROTC for three semesters while majoring in Aerospace Engineering. After not acquiring a scholarship Devin moved back to Jacksonville and finished his A.A degree at the Florida Community College of Jacksonville, where he was now majoring in mechanical engineering. Devin transferred to Florida State University in 2008 and is currently finishing up his Bachelors of Science degree in mechanical engineering and will be graduating in the spring of 2012.

Parker Brunelle:

Parker Brunelle is 23 years old and grew up in Snellville, Ga. He graduated top of his class out of high school and was one of the top recruited baseball players in the nation. He attended Florida State University on a baseball scholarship from Fall 2007 to

Spring 2012. Parker made the Dean's List eight times, was a four-year baseball letterman, and went to the College World Series twice. His senior season he received the honor of All-Atlantic Coast Conference Academic Team. He had an offer to play professional baseball with the Boston Red Sox, but will begin his career in engineering instead. He will be working for Enercon out of Kennesaw, Ga. starting in May.