



# Miniature Modular Rack Launcher Combo



**Senior Design Group 3**

**Casey Brown**

**Cyril John**

**Keith Kirkpatrick**

**Bryan Rickards**

# Overview

- Problem Statement
- Product Specifications
- Concept Generation
- Final Design
- Project Status
- Parts Received
- Potential Issues
- Gantt Chart

# Problem Statement

- Design and develop a Bomb Rack Unit (BRU) that is attached to the Tigershark UAV capable of housing and launching a cylindrical payload.
- BRU must contain an electrical box which will allow space for an electrical team to design and integrate an electrical interface to control in-flight operation of the BRU.
- Provide budget analysis for BRU
- Design and construction of a prototype

# Tigershark UAV Platform

## Specifications:

- Wing span 21 feet
- Propulsion - 372cc two stroke
- 20 gallon fuel tank
- Empty airframe weight - 150 lbs.
- Gross take off weight - 300 lbs.
- Payload capacity – 50 lbs.
- One hard-point location per wing for launcher attachment

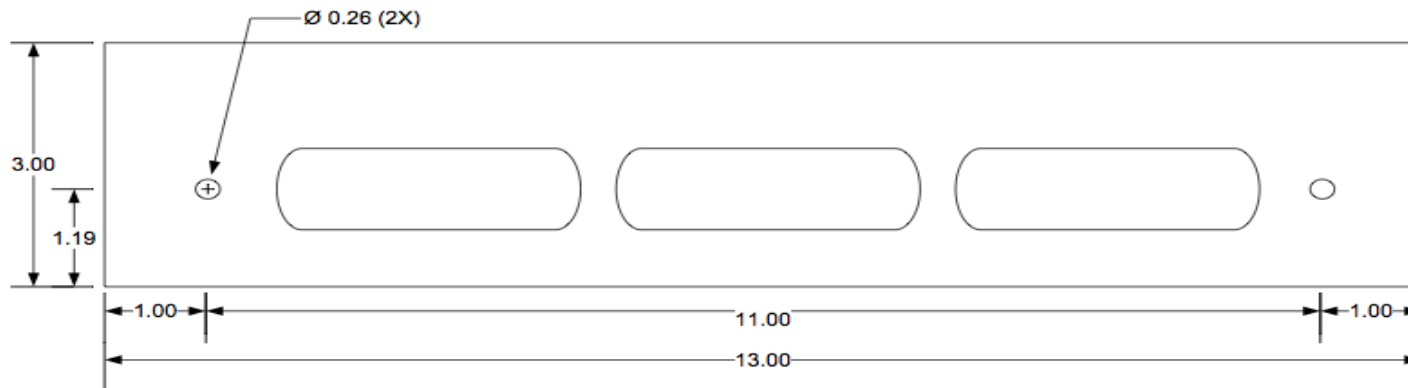

Made from 1" thick Aluminum  
Tolerance +/- 0.05"

# Constraints

- BRU must not exceed 5 lbs.
- Capable of holding a payload that is 10lbs
- Operation in temperature range -20 to 60 degrees C and during rain exposure
- Retain payload during aircraft maneuvers up to 2GS lateral load and 1G landing shock.

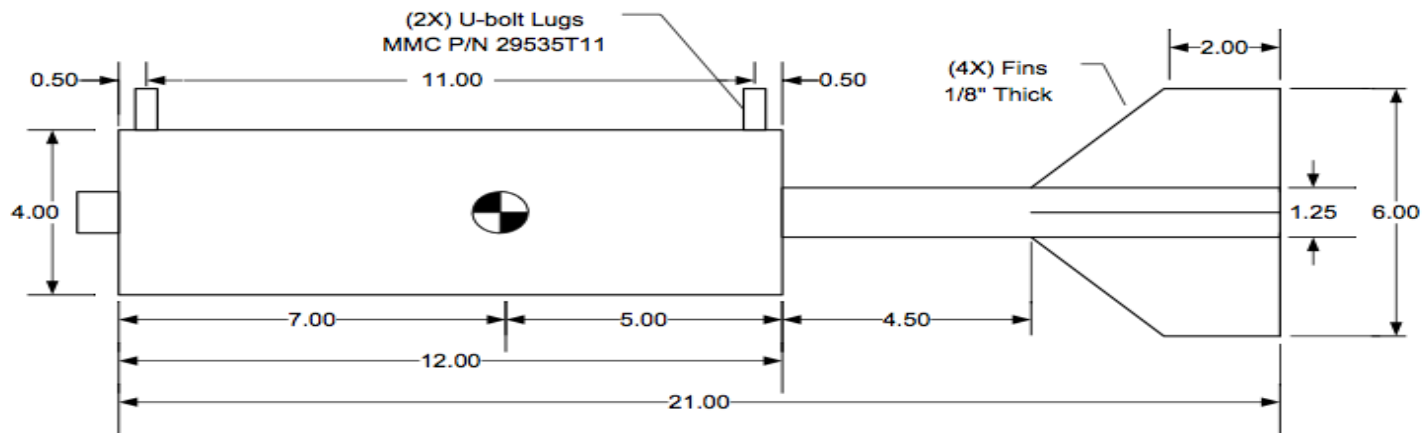

Weight = 10lbs  
Tolerance +/- 0.125"

# Concept Generation

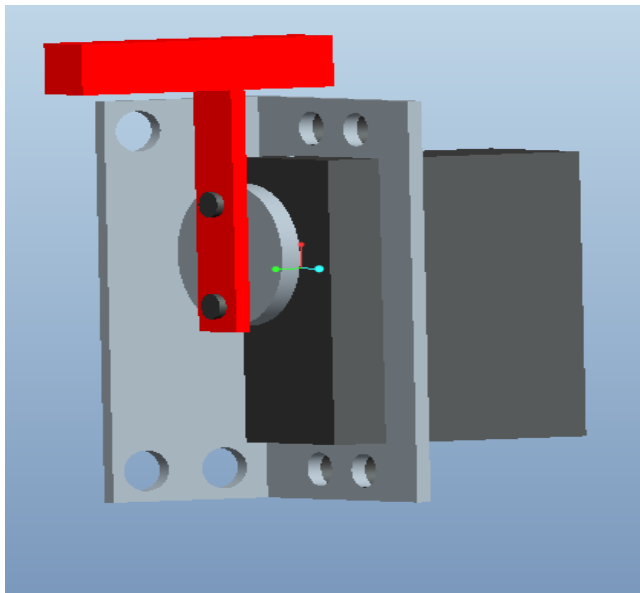
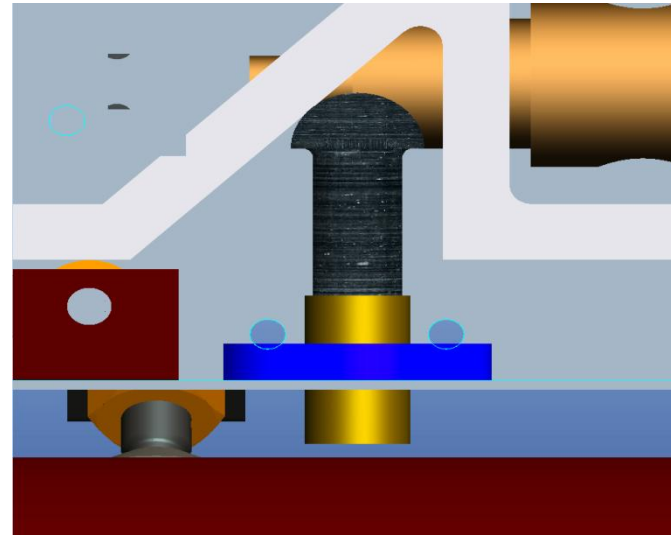
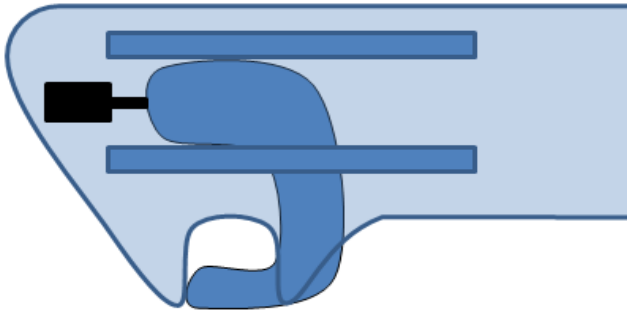

# Final Design

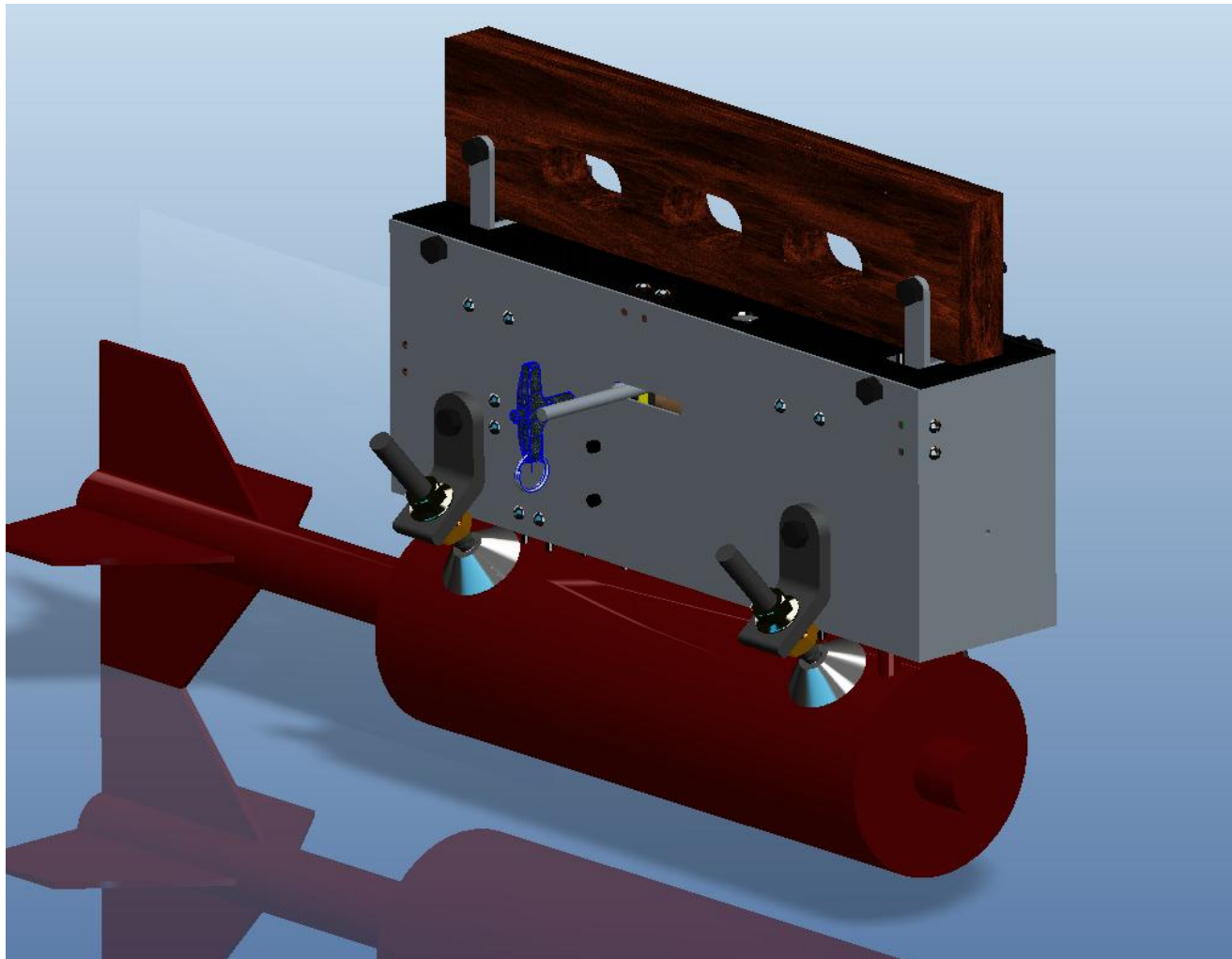

# Final Design

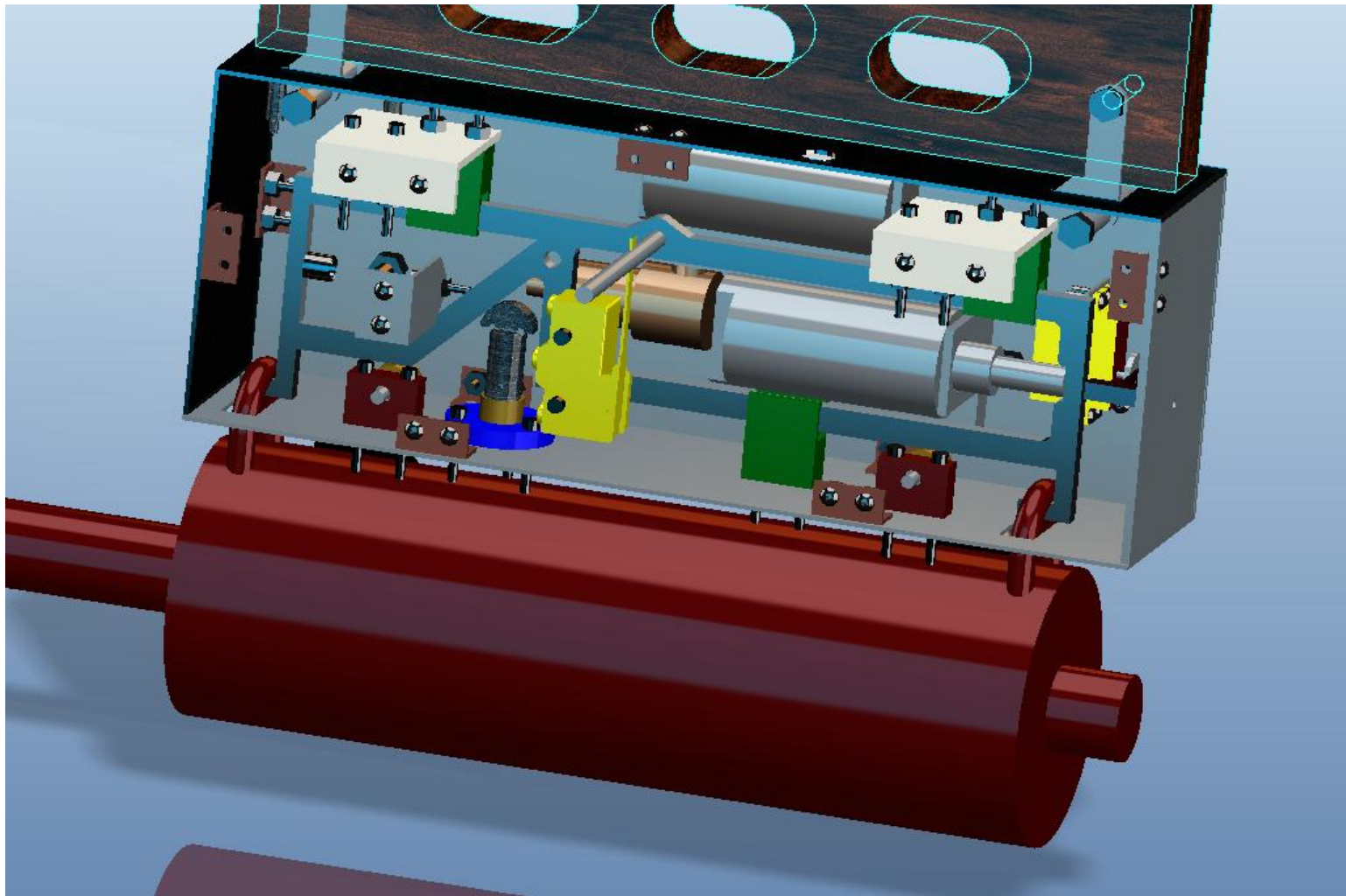



# Final Design

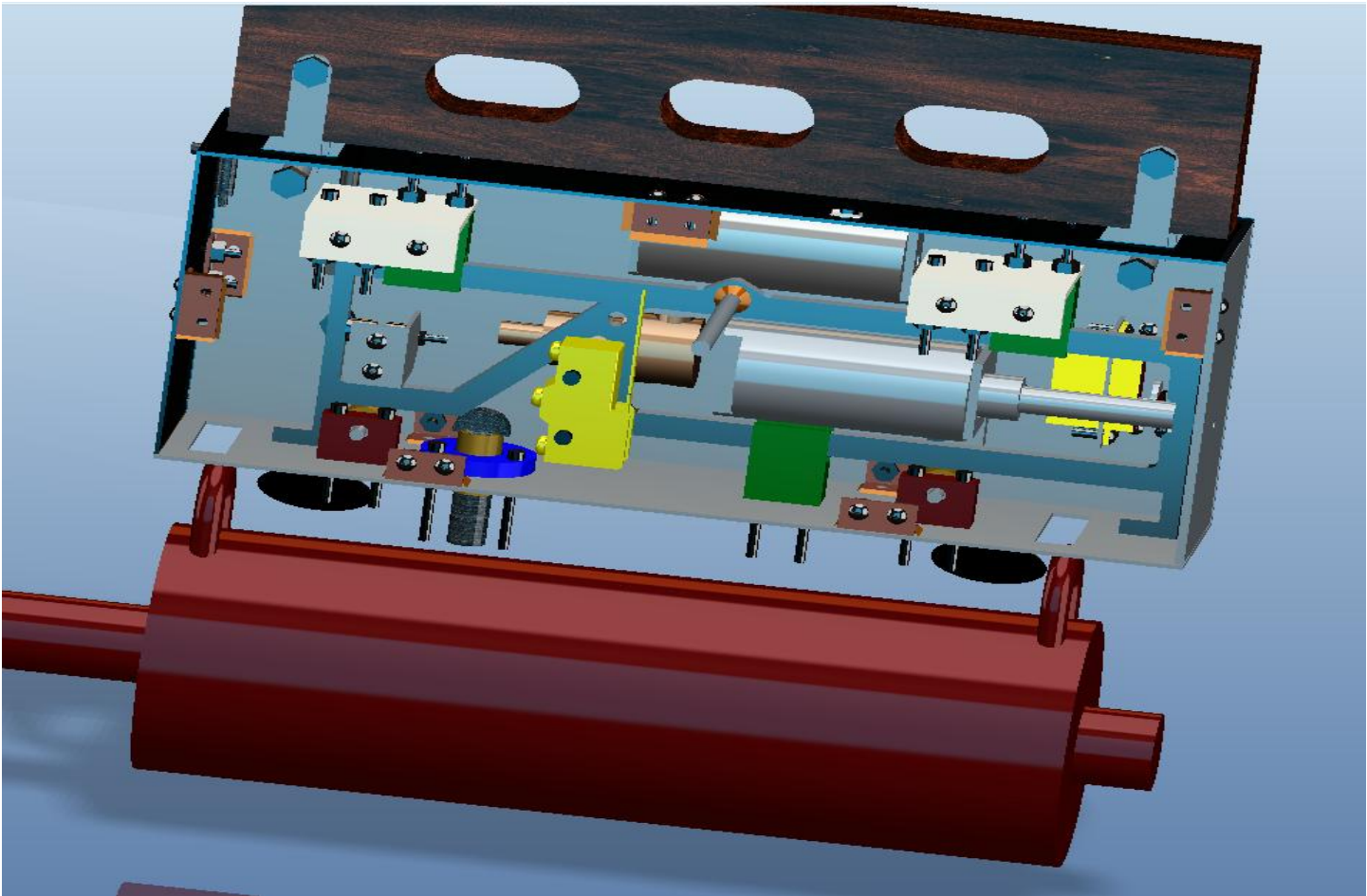

# Project Status

- Majority of parts have been received
- Submitted Purchase Orders
  - Raw Materials
  - Air Storage Tank
  - Solenoid Valve
  - Exhaust Valve
- Once raw materials received, submit part drawing to machine shop

<b>Purchase Items</b>					
<b>Part</b>	<b>Vender</b>	<b>Part Number</b>	<b>Price</b>	<b>Quantity</b>	<b>Total Price</b>
Air Cylinder	McMaster	6498K211	\$33.42	1	\$33.42
Air Tank	Clippard	AVT-24-4	\$16.82	1	\$16.82
Check Valve	McMaster	3208K22	\$14.74	1	\$14.74
Regulator	McMaster	99045K48	\$34.80	1	\$34.80
Solenoid	cylval	SA31NC	\$40.80	1	\$40.80
Exhaust Valve	McMaster	4149T41	\$35.55	1	\$35.55
Guide_roller	Grainger	1ZGT7	\$48.25	4	\$193.00
Ejector_bushing	McMaster	6377K114	\$20.27	2	\$40.54
Ejector_spring	Grainger	1NCT2	\$7.69	1	\$7.69
Pushspring	McMaster	9657K48	\$6.29	1	\$6.29
Servo	Futaba	FUTM0513	\$125	1	\$124.98
Limit Switch	McMaster	7090K37	\$7.91	1	\$7.91
RBF PIN	McMaster	90293A139	\$17.98	1	\$17.98
6-32 lock nut	Grainger	3HDT6	\$2.83	1	\$2.83
6-32x 1/2 screw	Grainger	1MU14	\$2.29	1	\$2.29
6-32x 1 1/2 screw	McMaster	91251A157	\$6.98	1	\$6.98
Leveling Foot	McMaster	2531k61	\$7.30	4	\$29.20
air connector	omega	OM-AIR-C24250418-5PK	\$5.50	2	\$11.00
air hose	omega	TYUTH95-1418-50-TRBL	\$21.00	1	\$21.00
female connector	omega	OM-AIR-C24260418-5PK	\$11.50	1	\$11.50
90deg elbow	omega	OM-AIR-C24470418-5PK	\$8.25	1	\$8.25
<b>Raw Material</b>	onlinemetals				\$102.54
<b>Total</b>					<b>\$770.11</b>

# Parts Received

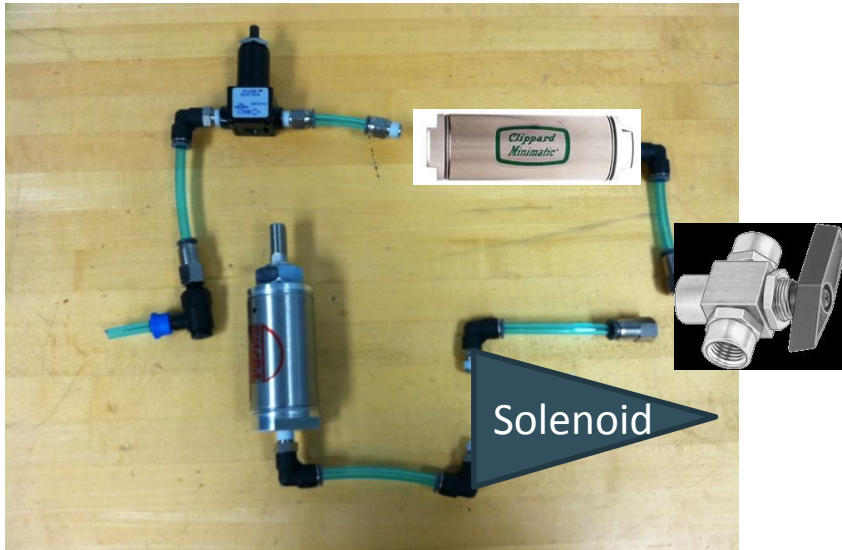

Pneumatic System



Servo Motor



Roller Bearing



Sway Brace

# Potential Issues

- Receiving remaining parts
- Proper machining
- BRU overweight
- Parts with incorrect dimensions
- Pneumatic system failure
  - Hook Release
  - Ejector
- Time constraint

<b><u>Material Weight</u></b>	
<b>Assembly</b>	<b>Total</b>
Hook Eject	1.0191
Mech Safety	0.0944
Ejector	0.1606
Pylon Attach	0.0574
BRU Casing	0.9515
Push Spring	0.0156
Pneumatic System	0.4213
Sway Brace	0.8803
Other	1.2808
<b>Total</b>	<b>4.881</b>

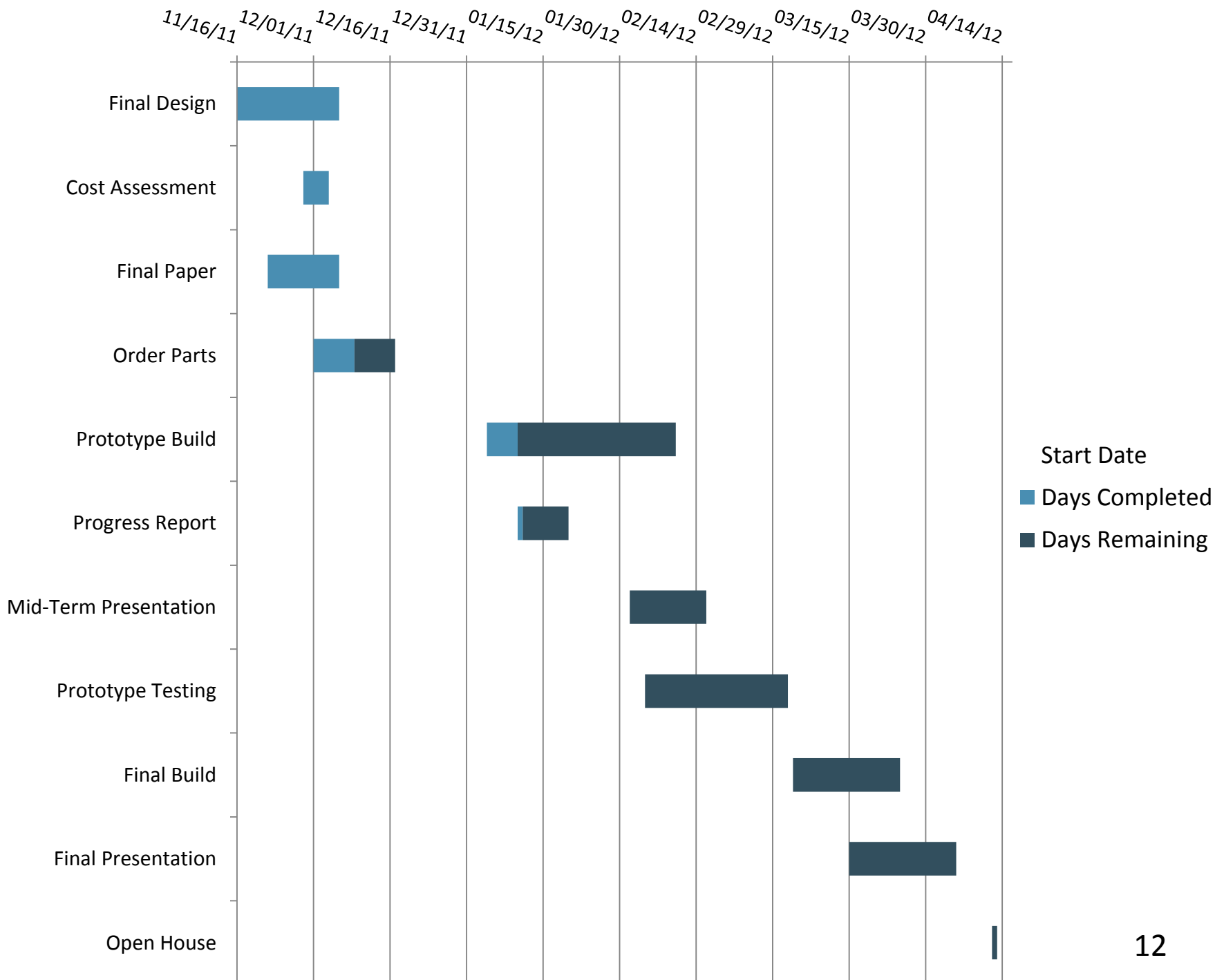



# Questions ????

