

FINAL REPORT

EML 4551C – Senior Design– Fall 2012 Deliverable
Team 10 – CISCOR Autonomous Ground Vehicle
December 11, 2012

Team Members:

Donald Alex
Tye Buckley
Richard Komives
Cesar Mize

Department of Mechanical Engineering, Florida State University, Tallahassee, FL

Project Advisors

Dr. Chiang Shih

Department of Mechanical Engineering

Dr. Kamal Amin

Department of Mechanical Engineering

Reviewed by Advisor(s):

Dr. Oscar Chuy

Department of Mechanical Engineering, CISCOR

Dr. Emmanuel Collins

Director, CISCOR



Table of Contents

Acknowledgments	3
CISCOR Introduction	4
Project Introduction	5
Project Scope	6
Background	7
Locomotion Mechanisms Introduction	8
Locomotion Actuator Designs	13
Mounting Material Selection	33
Cost Analysis	34
Safety Considerations	35
Environmental Considerations	36
Conclusion	37
References	38
Appendix A	39
Appendix B	46
Appendix c	49

Acknowledgments

We would like to thank the Center for Intelligent Systems, Control, and Robotics (CISCOR) for not only providing our vehicle platform but also providing us with all the necessary funding and resources for this project.

We would also like to recognize and thank our project advisors Dr. Oscar Chuy and Dr. Emmanuel Collins for their countless support and advisement throughout this semester.

CISCOR Introduction

The Center for Intelligent Systems, Control, and Robotics (CISCOR) uses engineering knowledge from the Mechanical and Electrical & Computing Engineering fields to develop new systems and implement technological innovations in the area of Intelligent Systems, Control, and Robotics. Their designs are used to solve practical problems in both industrial and governmental applications. CISCOR represents a cooperative approach for conducting interdisciplinary research in the automated systems area across two departments (Mechanical and Electrical & Computer) in the College of Engineering and the FSU Department of Computer Science. The Center's goal is to provide a means for the State of Florida to achieve national prominence in the area of automated systems and to assume a leadership role in the State of Florida's technology of the future. Established in 2003, CISCOR has become a leading center in Florida for the development and implementation of technologies related to Intelligent Systems, Control, and Robotics ("CISCOR").

Project Introduction

CISCOR has future projects which could make valued use of an autonomous off-road vehicle. No such vehicle currently exists in their inventory. Thus, CISCOR has tasked Senior Design Group #10 with modifying an existing off-road vehicle so that it can be autonomously operated. The vehicle for this project is a Polaris 550 Sportsman provided to the design team by CISCOR. To successfully complete this project, the resulting vehicle must be able to duplicate human-rider locomotion while being controlled solely through computers. The vehicle must also provide mounts and protection for the various sensors that will be utilized by CISCOR to gain data about the vehicle's environment. An additional constraint from the project sponsor is that the vehicle must remain human-rider operable in case of a failure of the computer controlled systems. The design should not excessively deviate from the capabilities of the original vehicle and should remain aesthetically pleasing. The resulting vehicle has been named **Gas Operated Land Intelligent All-Terrain VeHicle** or G.O.L.I.A.T.H.

To fully automate the operation of the GOLIATH, four basic locomotion systems must be altered to include a computer-controlled input. These systems consist of Steering, Braking, Throttle, and Gear Shifting. These designs must be rugged enough to withstand stresses and debris encountered in an off-road environment, while still maintaining the ability to reproduce human-rider like operation of the vehicle. These designs must also be very accurate due to the vehicles intended use as a research tested. Each locomotion system was tested for distance of travel required, force required, and reasonable response time for function. These values and the overall project constraints were used to design feasible systems to automate the locomotion. Input from the design group and the project sponsor was used to determine the final designs for each system. These designs, and their component selection are described in detail in this report.

Project Scope

Currently there is no off road vehicle platform for autonomous research and design in CISCOR's inventory. Therefore this team was tasked with modify an existing all-terrain vehicle (ATV) to be capable of full autonomous movement by designing, researching and manufacturing components to allow unmanned locomotion control.

Background

The increased use of autonomous vehicles both in the private and public sector has grown dramatically in the past forty years. The wide platform usage of these autonomous vehicles makes them a favorite among the defense sector and plays an integral part in today's battlefield. However, the battlefield is not the only place where these autonomous vehicles are used. Today, many commercial vehicles are more intelligent and responsive. Many modern cars now have the ability to adapt to terrain and different weather conditions automatically, which in turn relates to the autonomous functionality of an autonomous vehicle.

An autonomous ground vehicle (AGV) is a vehicle that operates while in contact with the ground and without an onboard human presence. AGVs can be used for many applications where it may be inconvenient, dangerous, or impossible to have a human operator present. Generally, the vehicle will have a set of sensors to observe the environment, and will either autonomously make decisions about its behavior or pass the information to a human operator at a different location who will control the vehicle through radio communication or other teleportation devices ("DARPA LAGR").

Most recently, autonomous research and development has significantly grown. Researchers and institutions are finding innovative ways to have these vehicles compute and respond to different environments and scenarios. At CISCOR, researchers hope to advance the field of autonomous intelligence by developing cutting edge technology and algorithms in this field.

Locomotion Mechanism Introduction

There are four main locomotion controls on GOLIATH: Steering, Braking, Gear Select, and Throttle. In order to achieve unmanned movement, all four components must be retrofitted with devices to actuate the desired response. Figure 1 illustrates the four locomotion controls on GOLIATH. Each locomotion mechanism is denoted as a subsystem.

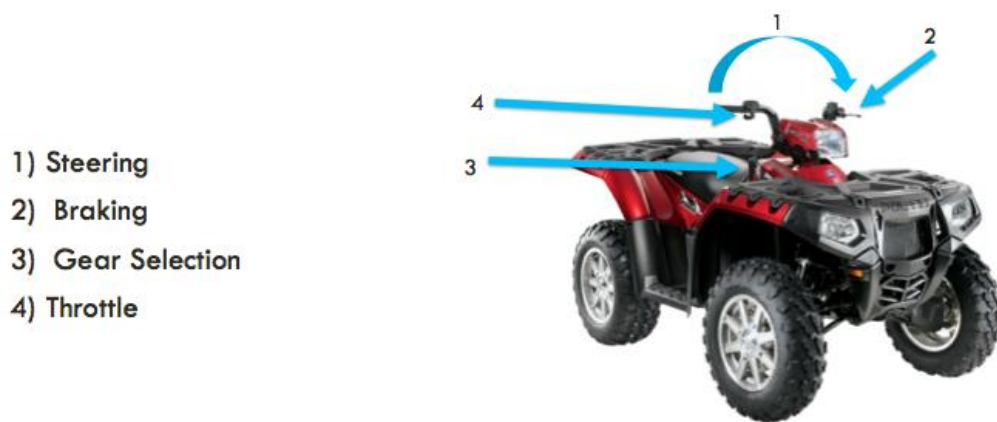

Figure 1 – Illustration of the locomotion controls on GOLIATH

Steering – Steering is the largest and most complex of all the subsystems. Multiple components go into the total assembly of this subsystem with many more micro-systems to each component. On GOLIATH, the steering motion is assisted by an auxiliary Power Steering Unit (PSU) that reduced the force required to turn the steering column. This feature is usually found on much larger vehicle and thus makes this a unique feature for an autonomous ground vehicle of this size. Figure 2 illustrates the steering component on GOLIATH.



Figure 2 – Steering Mechanism

The specifics of GOLIATHS steering characteristics are as followed:

Turning range: 162 degrees

Turning force required at end of handlebar: 32 lbf

Braking – The braking mechanism on GOLIATH works much like that of a bicycle brake system. When braking, a user pulls on the brake lever that engages the brakes. The brake lever however does not pull on a pull string much like that in a bicycle brake system but instead the lever pushing on a cylinder which pushes brake fluid across the braking system. The master cylinder is what actually activates the brakes in this system. Figure 3 illustrates the braking component on GOLIATH.



Figure 3 – Braking Mechanism

The specifics of GOLIATHS braking characteristics are as followed:

Braking travel range of lever: 1.85 in.

Force required to activate brake lever: 32 lbf

Gear Select – Gear selecting on GOLIATH is very straightforward. There is a single lever arm that can be pushed or pulled on to selected the different gear positions (Park, Reverse, Neutral, Low, and High). Figure 4 illustrates the gear select component on GOLIATH.



Shift Arm

Figure 4 – Gear Select Mechanism with arrow point to shift arm

The specifics of GOLIATHS gear select characteristics are as followed:

Force Required to shift gears: 30 lbf

Total travel of lever arm: 4.1 in.

Distance between different gears: max of .5 in.

Throttle – Throttle actuation on GOLIATH is also very straightforward. The throttle actuator is located on the right handlebar and is actuated by the right thump. If a user wishes to accelerate, he pushed on the throttle lever and the vehicle accelerates forward. Figure 5 illustrates the throttle component on GOLIATH.



Figure 5 – Throttle Mechanism

The specifics of GOLIATHS throttle characteristics are as followed:

Total throttle lever travel: 45 degrees

Force required to actuate throttle: 8 lbf at 2 cm from axis of rotation

Locomotion Actuator Designs

Braking

To meet our goal of automating all the locomotion systems of the ATV, a braking system must be devised that allows a computer input to precisely control the amount of braking force applied to the vehicle. Like the other locomotion systems on the ATV, the braking system requires accurate operation, fast response times, and the system must not be designed in such a way as to render the ATV inoperable by a human rider. Other factors, such as cost, simplicity, and aesthetics, factored into the final design of the autonomous braking system.

Design Selection

The current braking system operates by having the rider of the vehicle depress a hand-lever located on the left handlebar. This lever pivots about a pin on the handle bar and the rotating motion of the lever causes a piston in the master cylinder to be depressed. The depression of the piston inside the master cylinder pressurizes the fluid in the brake lines, causing the calipers located at all four wheels to engage the brake pads. To accurately determine the braking force being applied to the vehicle, the pressure of the fluid inside the braking lines must be known. The position of the piston in the master cylinder relative to its rest position can also be used to infer a braking force. The project advisor requested that the final system be able to record and report both data points.

Multiple designs were evaluated that met the basic requirements for successfully automating the braking system. One of these designs used to a linear actuator to directly depress the brake piston, obviating the need for the brake lever. Another design used the same method, but included another brake cylinder, spliced into the existing brake lines. This effectively created a parallel braking system. The final design concept and the one which was eventually selected with the project advisors approval is a design in which the linear actuator acts upon the brake-lever so as to depress the brake piston in much the same manner as the existing system is currently operated by a human rider. The decision matrix that was used to select this design is located in the appendix. Figure 6 illustrates this design.

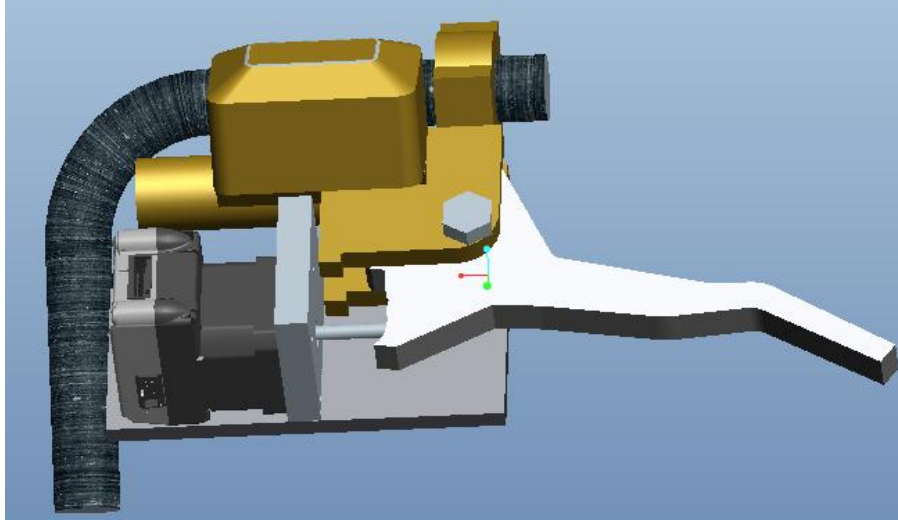

Figure 6 - Final Braking System Design

The CAD model above shows a linear actuator mounted in front of the existing braking system on the handlebars of the ATV. This actuator acts upon a protrusion of the brake-lever causing it to pivot about the pin and depress the brake piston. This design meets the specified requirements for the locomotion systems of the ATV and does not interfere with the operation of the existing braking system by a human rider. This model does not show the method for measuring the brake line pressure, which will be mounted in a different area.

Component Selection

The most important component in this system is the linear actuator which will be used to rotate the brake-lever. It is this component which the entire system, excepting the method for measuring the brake line pressure, will be designed around. For the actuator to be mounted in the desired location in front of the handlebars, the actuator must be of a small size so as to not interfere with other vehicle components mounted inside the handlebars which included the vehicles headlight. The mount on the front of the handlebars is in a very visible location to observers of the vehicle, which makes the aesthetics aspect of the design more prominent than other possible braking system designs. The current design is also significantly exposed to any dust, debris, or moisture which may be present in the environment. To enhance the aesthetics of the design and to combat damage due to debris, a plastic housing which encases a significant portion of the design will be used. This housing will be easier to design and will be

more aesthetic the smaller it is, thus reinforcing the need for a small linear actuator. The housing is not shown in the CAD model above to make other components of the model clearer.

The actuator used in this system must also fit the criteria for strength and accuracy. The force need to depress the brake piston through its maximum travel was determined by measuring the force exerted on the brake lever at a certain distance, and then converting this force through the use of moment arm equations into a force directly acting upon the brake piston. After the calculations using Equations 1 in Appendix C, this force was determined to be ~ 35 lbf. To provide a small margin of error, it was determined that an actuator with a minimum of 50 lbs. of thrust force would be required to directly depress the piston. The final design does not utilize the actuator directly acting upon the piston, but instead uses the portion of the brake-lever acted upon as a moment-arm to then depress the piston. This means that the actuator will actually require less than the 35lbf. to depress the piston. The actuator used in the braking system was also required to have some manner of measuring its displacement during operation. This is achieved with actuators using either a potentiometer or a type of encoder. After discussion with the project advisor, it was determined that a potentiometer would not be sufficient to achieve this constraint due to the high probability of failure after repeated uses. Thus, some type of encoder, preferably one integral to the actuator, would be needed to provide position feedback. The actuators which include encoders are much more expensive than those with more limited means of positional feedback. This was taken into account during the search for an adequate model, and every effort to find a sufficient, cheap actuator was made.

Due to safety concerns, and the effective operation of the vehicle in unknown terrains, the braking system must also be able to develop full braking force in a short amount of time. This reduces the chances of collision with objects which are not detected by the sensors until they are in close proximity to the vehicle. The response time of the system is dependent upon the total displacement of the linear actuator that is required for the maximum braking force to be applied and the speed of the actuator.

Finally, due to limitations imposed by the power supply from the operation of the vehicle itself, and the power consumption from the many other components of the final autonomous vehicle, the actuator must be operable with an input voltage no higher than 24 VDC. Using these criteria, the M-Drive 17 linear actuator manufactured by Schneider Electric, shown below, was chosen.



Figure 7 - Linear Actuator

This actuator features an internal 512 line magnetic encoder which allows for a resolution of 2048 steps per revolution of the actuators drive motor. This actuator is able to generate more than 50 lbf. of thrust, exceeding the strength constraint determined earlier. The range of input voltage for this actuator falls between 12 and 48 VDC, encompassing the necessary low voltage range. Using the high load scenario of 50 lbf. of thrust and the travel length necessary to achieve full braking force, the system will develop full braking force in less than one second from receiving the command signal. This actuators command and control systems were sufficiently compatible with the other systems of the autonomous vehicle. After presented with the technical specifications and the price, the project advisor approved the procurement and use of the actuator for the braking system.

The actuator also filled the required small size constraint. Shown in Appendix B, the rough dimensions for this actuator are 2.3" x 2.2" x 1.7", which is easily mountable in the space in front of the handlebars without interference with existing vehicle components.

This actuator features a screw with a flat end which will be placed against a surface on the brake lever. The revolution of the screw by the actuator causes the end of the screw to displace relative to the actuator, causing the screw to force the brake lever to rotate.

While the linear actuator will possess an encoder to provide feedback about the operation of the braking system, the project advisor desired to have another, redundant feedback system that would be more accurate. This will be achieved by connecting a pressure transducer to the brake lines so that the pressure developed in the lines, which directly leads to the braking of the vehicle, can be measured. The transducer will be mounted on the brake line between the brake master cylinder and the distribution valve which allows the brake fluid to activate the brakes on all four wheels simultaneously. After discussion with the project advisor, it was determined that the criteria for selection of the pressure transducer was that it must be accurate, have a fast response time, be cheap, and produce a voltage output to determine the measured pressure. The use of a pressure gauge with a visual dial would not be necessary to achieve this portion of the system and would drastically increase the price of the transducer. Due to this item being more common and less critical to the overall operation of the braking system, an additional constraint to procure the item from a company on the previously approved procurement list if at all possible was added.

To begin selection of the transducer, the range of pressures developed in the brake lines during operation must be measured. Due to the fact that very little flow of the brake fluid occurs in the brake lines during operation, the static pressure of the fluid is the only necessary measurement. This was done by connecting the existing brake line to a small, analog pressure gauge and determining the maximum pressure that developed when the brake piston was fully depressed. This was approximately 730 psi. Using this pressure reading, and the other criteria, the companies listed as per-approved for procurement were checked for applicable products. It was determined that the PX309-1KG5V from Omega Engineering sufficiently met all the criteria. The selected transducer is shown in figure 8.

HOW TO ORDER PX309 SERIES WITH 0 TO 5 Vdc OUTPUT

0 to 5 Vdc Output
0-1 to 0-10,000 psi
0-70 mbar to 0-690 bar



To Order Visit omega.com/px309 for

RANGE		1.5 m CABLE CONNECTION	MOUNTING CONNECTION
bar	psi		
ABSOLUTE PRESSURE			
0 to 0.34	0 to 5	PX309-005A5V	PX
0 to 1	0 to 15	PX309-015A5V	PX
0 to 2.1	0 to 30	PX309-030A5V	PX

Figure 8 - Pressure Transducer

The selected transducer has the required voltage output, with a range of 0 to 5 VDC and has a range of pressure from 0 to 1000 psi. The transducer will work with the liquids like that found in the brake lines. This transducer has an accuracy of $\pm 0.25\%$ of the static pressure and a response time of under a millisecond. The actuator will be connected to the existing brake lines using a 1/8" flare tee commonly used on brake lines and an adapter from the brake line tee to the NPT threads of the transducer. This will cause minimal interference in the normal operation of the braking system. After presented with the technical specifications and the price, the project advisor approved the procurement and use of the pressure transducer for the braking system.

The correct mounting of the autonomous braking system features complex geometries determined by the limited space, the angles of the handlebars relative to the braking master cylinder, and the need to account for the arcing motion of an object pivoting around a fixed point.

The actuator is mounted vertically on a base plate connected to the existing master braking cylinder with bolts. The actuator will be allowed to rest on this plate, since forces in the vertical direction will not develop during operation of the system. The actuator will be constrained from lateral movement by connection to a vertical plate connected to the base plate. The four threaded holes shown in the figure displaying the linear actuator dimensions will be used to connect the actuator to the vertical plate. The four bolts used to make this connection will also resist any torqueing or motion of the linear actuator perpendicular to its travel. The existing brake handle does not possess a convenient place for the linear actuator to act upon, so a new brake handle will be manufactured with an altered geometry to best achieve smooth travel during operation of the autonomous system. These components of the braking

system will not be enclosed by the plastic housing which will protect the actuator, and thus will need to be able to resist rust and corrosion. The pieces may also require modifications after the initial manufacture to better fit the vehicle. To ensure that the pieces are cheap, easily machine-able, and corrosion-resistant, aluminum was chosen as the material to use for their manufacture. None of the designed pieces would be thicker than 0.45" or large in any dimension than 12" making procurement of the basic stock from any metal provider very fast, reducing lead time and price. The geometry of the initial design is simple to enable fast manufacture using water-jetting so that the mounting components can be fit-checked, and then adjusted if needed.

Ongoing Work

Currently the major system components are in procurement and the material for constructing the mounts is already acquired. Fit-checks are being conducted of the various system components utilizing laser-cut 2D renderings of the components in ABS. These fit-checks are then used to modify the existing Pro-Engineer models in the final design.

Work for the Spring Semester

As components of the system are delivered, more precise fit-checks of the mounting components are possible and the model is continuously updated to retain accuracy. After mounting of the final braking design, the operation of the design will be measured to ensure compliance with the desires of the project advisor.

Steering

In order to make the ATV fully autonomous, a steering system must be designed that allows for full computer control. Our steering system must be able to utilize its full range of motion, it must be able to withstand all feedback from the terrain, and the motor output must be powerful enough for any terrain and speed. The system must also be designed in such a way that allows for full user control when necessary. When assessing possible designs we also took into account other factors, such as cost, lead time, simplicity, and reliability.

Design Selection

The steering system of the ATV works by having a user turn the handlebars clock-wise or counter-clockwise. Attached to the handlebars is the steering column. The lower portion of the steering column is then connected to the power steering unit (PSU). When the user turns the handlebars, which turns the steering column, a torque sensor in the PSU determines which direction the steering column is turning and activates a brushless motor to aid in steering the vehicle. A secondary steering column extrudes from the bottom of the PSU which connects to linkages and tie-rods which physically makes the wheels turn. A basic drawing of the PSU and connected steering columns is show in Figure 9.

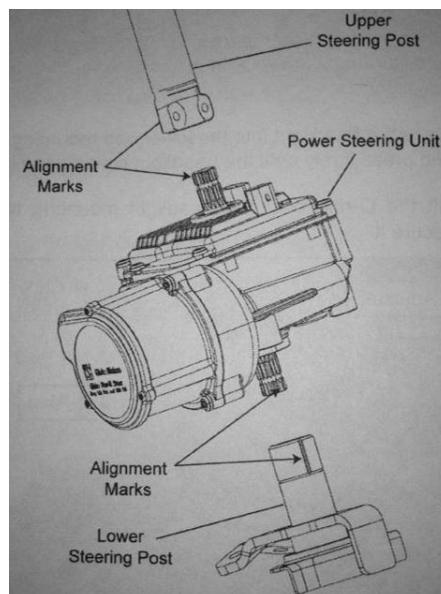

Figure 9 – Globe Motors power steering unit on GOLIATH

Before considering any design possibilities, it was important to determine two important parameters involved with the steering system. These two parameters went along with the goals that we had set previously. We had to determine the full range of motion of the steering column (in degrees) and torque required to turn the steering column (in Nm). The range of motion was found simply using a protractor and graph paper. The torque required was found by attaching spring scales to the end of the handlebars and determining the force in kg needed to turn the wheels. Using Equation 1 in Appendix C, the max torque was calculated to be 14Nm.

Initially, three main designs were presented to actuate the steering system. The first design involved adding a third handlebar to the front of the steering column. This third handlebar would then be attached to a block which slid along a linear track. A linear actuator would move the block forward and back to steer the vehicle. We felt that this design was insufficient because it limited the range of motion of the steering system. The second design was to mount a motor in front of the steering column. This motor would have a block connected to its shaft with two arms protruding from it that would connect to a similar block rigidly mounted to the steering column. This design also limited the range of motion of the steering system. The final design also mounted a motor in front of the steering column. Using pulleys and a timing belt, the motor would turn the steering column. This design, of the three, was the one that we selected because it met all goals required of it. During the process of motor procurement, a discovery was made that halted all progress we were making in that direction. A serial number and company name was read from a decal on the PSU. After researching the company who builds the PSU, Globe Motors, a call was made to their engineering department to determine whether or not the PSU had enough power to steer the vehicle on its own and whether or not it was programmable in any way. This discovery led us to completely halt all progress on the previous design and switch direction towards working with the PSU.

Component Selection

While speaking with Dennis Mueller, an engineer at Globe Motors, we found out that the current PSU was able to output approximately 60N*m of torque. This torque rating is almost four times the calculated requirement to steer the vehicle. This meant that the current PSU could easily steer the ATV on its own. The only issue with the current PSU was that the only sensor in use was a torque sensor. This meant that even if the PSU could be programmed, there would be no feedback. Feedback from the system is necessary for the ATV to be able to determine its location. This led to a second conversation with Dennis at Globe Motors to explain a bit more about what we are trying to do and if any other options are available to us. Dennis informed us of a different PSU the company offered. This PSU, like the original, was

run by a brushless motor and a torque sensor. This PSU fortunately differed in two areas. This PSU was able to be programmed and was built with an embedded absolute encoder. This absolute encoder would allow the system to always know the angle of steering, even after the system has been shut down and restarted. The programming protocol was told to be J1939. This is a common vehicle communication protocol used in most automobile designs. What enhanced the prospect of this solution was that we were informed that this design has been used previously for making ATVs autonomous. Currently, Globe Motors is working on over 100 units for the military and has already sent out units to over 10 universities in the nation. The final issue that allowed us to officially select this design option was that this PSU was specifically designed for the Polaris 550 EPS. This meant that it has the exact mounting profile as our current PSU. This will cut out manufacturing time completely and greatly reduce installation time.

Ongoing Work

Currently, we are in the process of discussing with Dennis how to communicate with the PSU. We know the communication protocol but we are trying to determine exactly what type of code needs to be sent to the PSU. Once that is determined, we are hoping to place an order with Globe Motors, hopefully before the end of the semester. The current pricing of the unit is approximately \$2000. This price is slightly higher than the cost of previous designs. The added cost has been determined to be worthwhile because of the proven reliability of the unit. The lead time is approximately 1.5 months, so we are hoping to get the new PSU delivered by late January or early February.

Work for the Spring Semester

Once the new PSU is received, we will begin the removal of our current PSU. Full removal and installation documentation has already been acquired. After mounting, code will be written for the unit that will allow for testing to ensure full compliance with all requirements set by our project advisor.

Gear Select

In order to have full autonomous motion of the ATV (GOLIATH), we must implement a mechanism to control the gear or drive selection. Specific measurable objective must be met in order for full control. The mechanism must be able to have full range from first to last gear, Park to High-forward, while having the ability to stop at each gear in between. Along with being able to perform this operation with accuracy and repeatability, the system must also overcome the force required to move the gear selector. Other, more general factors, such as cost, durability, and aesthetics will be implemented in our final design.

Design Selection

The Polaris Sportsman EPS 550 comes with five different gear selections: park, reverse, neutral, low-forward, and high-forward, in order from the driver to the front of the ATV. To select different gears the rider pulls/pushes on the shift arm till the correct gear is selected. There is a digital feedback to let the rider know what gear they are in. Shown in figure 10, the shift arm is mounted about a pivot joint. The arm is coupled to the motor gear input selection by a connecting rod.

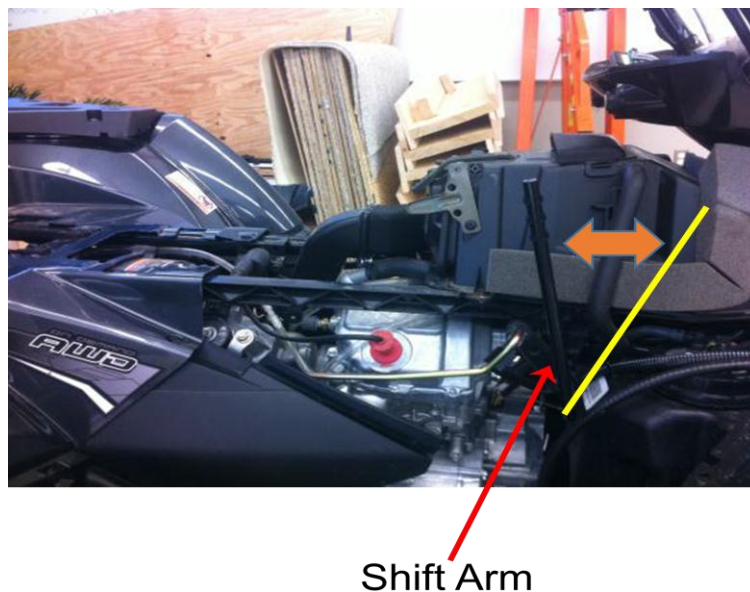

Figure 10 - Shift Arm Location and Motion

Two main design options were assessed, both of which could accomplish all gear locations. One option was a servo directly mounted to the motor. This eliminated moving parts simplifying the process. Mounting options were one of the biggest limiting factors with this design. Also, another constraint was placed on the project by our advisor which required the vehicle to still be able to perform standard user operation. This eliminated a servo mounted design option. The second and selected design was to use a linear actuator to perform the required motion. The actuator can be placed in line with the shift arm, and when activated, could locate the shift arm to the specified location. GOLIATH has an aluminum plate located in the front that would allow for the linear actuator to be mounted in-line with the shift arm. In order to still permit user interaction, the coupler from the linear actuator will be designed to allow for a quick disconnect. By using a linear actuator design with a coupler link, all of the criteria for complete control of the shifting mechanism are satisfied. The design mount and location is illustrated in the figure below.

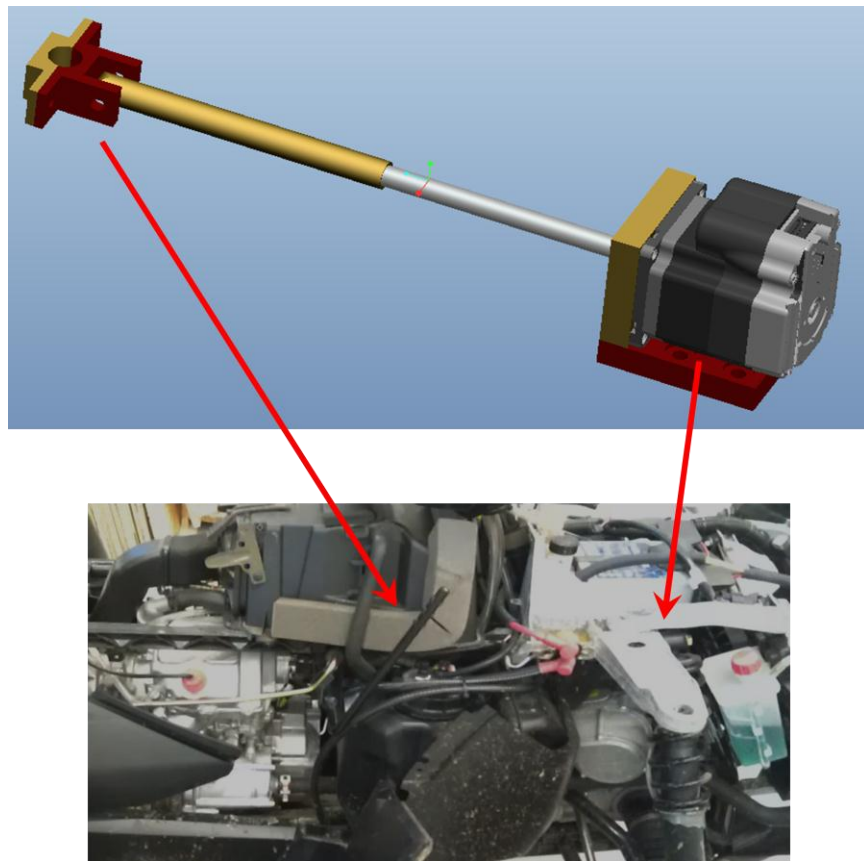

Figure 11 - Mounting Design and Location

Component Selection

After the design concept of using a linear actuator to select the different gears of GOLIATH was chosen, an actuator was selected that met very specific design criteria. Some of the requirements are solely due to performance specifications while others are due to design choices by the team.

Due to their high importance, performance specifications were the main driving force behind the selection of the linear actuator. One of the main specifications is the actuator needs to be able to overcome the 30 pound-force required to move the shift arm between the locations. This force was found by using a mass spring scale with a specific spring constant. By connecting the springs to the shift arm and measuring the displacement of the spring required to move the shift arm, a total force required for movement could be calculated. In addition to the force requirement, the actuator must have a total travel of at least 4 in with the ability to stop at different locations. From park to high-forward the shift arm travels a distance of 4 in. Gears from park to low-forward are separated by 0.75 in each while 1.5 in separates low-forward to high-forward.

Other criteria placed on the selection process by the team, included an accuracy requirement of 0.01 in along with a total time from park to high-forward of 5 sec. Also, for programming purposes a location feedback is need. The location need to be transmitted by a non-contact encoder. One of the final things considered in the selection process is the actuator must be heavily resistant to vibrations. Dust and debris effects were considered and will be avoided by the use of a housing to encompass the actuator.

In addition, due to the performance ability of GOLIATH and the components that it will have to support, the power supply is limited to a maximum of 24 VDC. Thus the linear actuator must be able to perform all of its required specification with the allotted 24 VDC.

Using these criteria, the team selected the M-Drive 23 non-captive linear actuator by Schneider Electric. This actuator is shown in figure 12.



Figure 12 – Schneider Electric M-Drive 23 Linear Actuator

The M-Drive 23 by Schneider Electric is capable of producing up to 200 lbs of thrust. The non-captive shaft has a specified 7.5 in total length, which encompasses the required 4 in of travel. With the selected thread option of 0.001 in per step and running at a speed of 2000 step per second, the M-Drive 23 can complete the required 4 inches in 2 sec, theoretically. The M-Drive can operate at 24VDC, complying with the power output from GOLIATH. A 512 line magnetic encoder allows for 51200 steps per revolution.

As depicted in the figure 12, the shaft will have a threaded end, UNC ¼-20 thread, which will serve as the mount for the coupler link. The coupler will serve as a connecting rod from the linear actuator to the shift arm. By not rigidly connecting the actuator and shift arm, a user could easily disconnect the two if power were loss to the system and resume normal operation. Figure # shows how the coupler will be connected to the shift arm.

Coupler Design

One main specification for the coupler is that it needs to be able to handle the motion of the shift arm. Because the shift arm is located about a pivot point, the motion of any point along that arm is a two dimensional planar motion. The coupler must then be able to transform the two degrees of freedom output of the shift arm to the one degree of freedom input from the actuator. This can be accomplished by combining multiple joints with different degrees of freedom. By joining a slider joint and a pivot joint,

we are able to translate two degrees of freedom into one. Therefore, when the linear actuator is in motion the pivot joint will account for the angle of the shift arm and the slider joint will account for the change in height of the connection point.

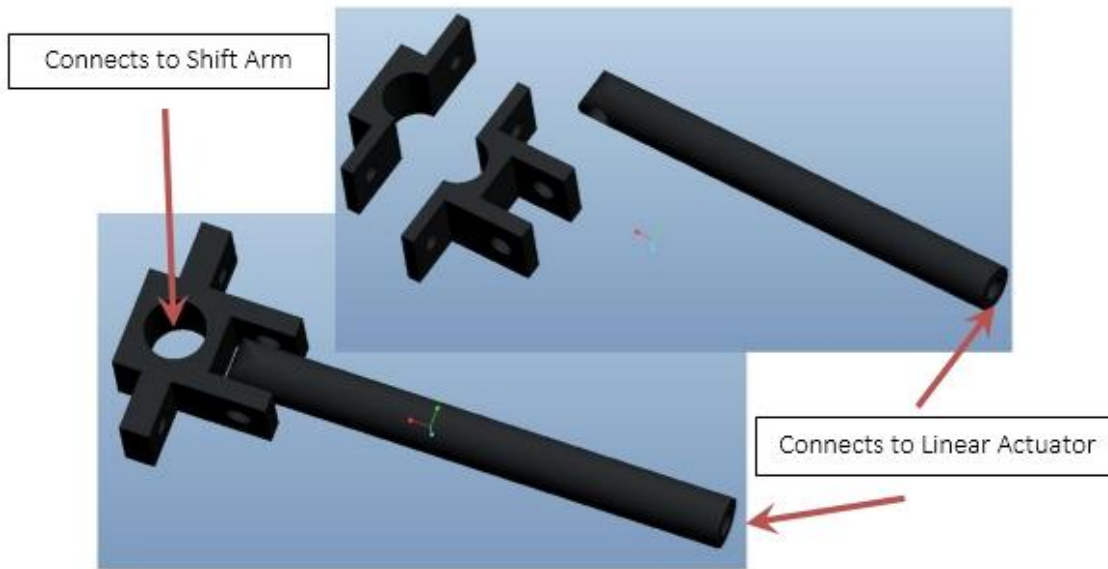

Figure 13: Coupler from Actuator to Shift Arm

Mounting Design

In order to mount the linear actuator to the metal arm, shown in figure 13, a simple L-shaped bracket will be used. Four screws will mount the actuator to the bracket. This will limit the actuator from slipping back and forth while under the forces required to move the shift arm. A strap will be used to hold the actuator on the mount. This was decided by the team for several reasons. One is the multiple communication ports that we need to have access to. Another reason is the simplicity of removing the actuator if necessary. Due to minimal forces in the vertical direction, it was determined that the four mounting screws and strap would suffice in holding the linear actuator in place during operation. Figure 14 shows the mounting configuration for the linear actuator.

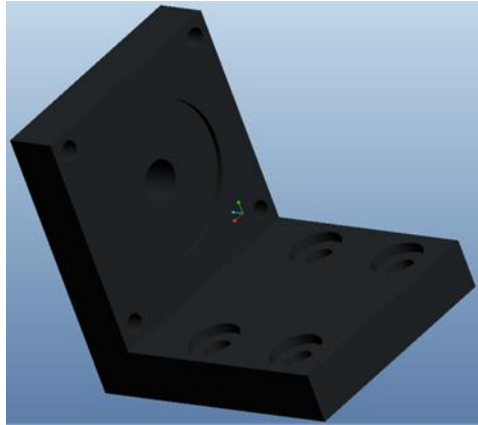

Figure 14 - L-Shaped Bracket for Actuator

Ongoing Work

Currently, to date, we have already received the M-Drive 23 Linear actuator. All of the components have been modeled and approved. After dimensioning is complete, diagrams will be submitted to the machine shop for fabrication. Material for the mount is in stock, which leaves only ordering aluminum for the coupler. The lead time for the aluminum rod and coupler joint is around 3 days. With the aluminum being ordered the week of December 9 and the drawings submitted, all parts should be completed and ready by January 1.

Work for the Spring Semester

Due to already having the actuator and mounting process being simplified, installation, programming, and testing will be taking place during the spring semester. This places the group exactly on track if not slightly ahead of the Grantt Chart schedule. By being ahead of schedule we can make sure the mounts are flush and operate flawlessly. It is definitely foreseeable that the shifting system will be completed on time.

Throttle

In order to have full autonomous motion of the ATV (GOLIATH), we must implement a mechanism to control the throttle. Specific measurable objective must be met in order for full control. The mechanism that will be used to control the throttle must utilize the whole range of throttle capabilities of the ATV. In other word, the system must be able to accelerate from zero to its top speed of roughly 60 mph. Furthermore, the system must be accurate and responsive. We would like the system to be able to be able to have the accuracy to specify the exact speed it so desires. The response time of this system is also to be considered. The system must meet or exceed the response time of a human actuating the throttle mechanism. Other, more general factors, such as cost, durability, and aesthetics will be implemented in our final design.

Design Selection

To accelerate on the Polaris Sportsman 550 a user utilizes a thump throttle lever located on the right handlebar as depicted in Figure 15. When exploring initial design concepts, the group came to the conclusion that simplicity was key in designing a system to actuate the throttle. We also considered in our design selection the ability to have the throttle actuator system seamlessly be able to be user driven without disconnecting of components. That is, a user can mount onboard GOLIATH and actuate the throttle without any modification to the unmanned actuator throttle system.



Figure 15 – Factory installed throttle actuator mechanism

With all these design considerations, the following is the final throttle actuator design for GOLIATH. This throttle actuator system will mimic a rider's thumb pushing on the throttle. This will be done by mounting a high torque stepper motor with the output shaft turning a mechanical arm. This mechanical arm will be coupled to a slider that will push the throttle lever when the stepper turns. Figure 16 illustrates this design. This design not only allows for a user to directly manipulate the throttle freely but also satisfies all measurable objectives when coupled with the Schneider Electric 23 M-drive stepper motor.

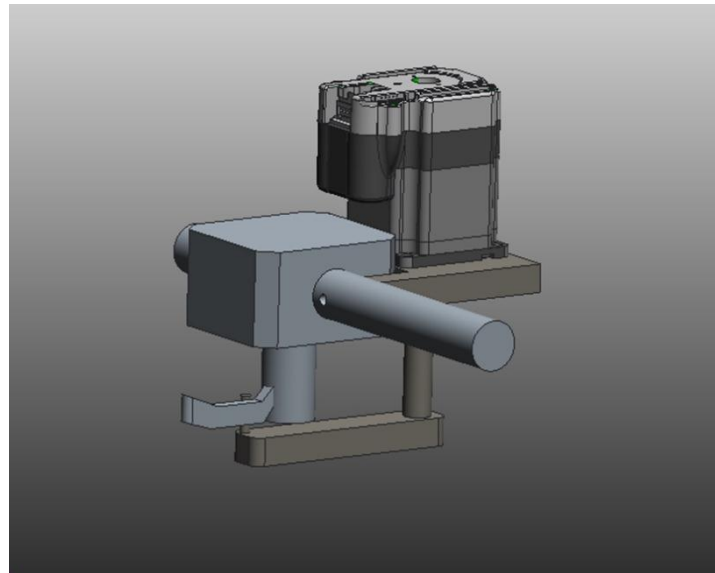

Figure 16 – Throttle actuator for unmanned locomotion

Component Selection

After the design concept of using a stepper actuator to actuate the throttle mechanism of GOLIATH was decided upon, a stepper motor was selected that met very specific design criteria. Some of the requirements are solely due to performance specifications while others are due to design choices by the team.

Due to their high importance, performance specifications were the main driving force behind the selection of the stepper motor. One of the main specifications is the actuator needs to be able to overcome and hold the .84 Nm required to actuate the throttle mechanism. This numerical value was computed by calculating the torque at the center of the throttle lever using a spring mass system and a

perpendicular distance. Equation 1 in Appendix C was used for this. This torque was found by using a mass spring scale with a specific spring constant. By connecting the springs to the shift arm and measuring the displacement of the spring required to move the throttle arm at a known distance from the center.

Accuracy was also a major criteria for motor selection. Due to the relative small angle produced as the throttle travels from 0 to max, which is roughly 40 degrees, the motor must have a large resolution to allow such small travel and still maintain accuracy.

In addition, due to the performance ability of GOLIATH and the components that it will have to support, the power supply is limited to a maximum of 24 VDC. Thus the stepper motor must be able to perform all of its required specification with the allotted 24 VDC.

Using these criteria, the team selected the M-Drive 23 stepper motor by Schneider Electric. This motor is shown below in figure 17.



Figure 17 – Schneider Electric M-Drive 23 Stepper Motor

This motor provides the following specification as they relate to the throttle manipulation:

Holding torque: 1.60 Nm

Resolution: 51,200 steps per revolutions

Speed: Operating limits from 0-4000 RPM's

Mounting Design

The mounting design for this locomotion component is very simple. The mount will be directly bolted onto the handlebar by two M5 screws. The mount will be placed perpendicular to the throttle assembly and will not affect any factory installed components of GOLIATH. Figure 18 illustrates the mount for the M-Drive motor.

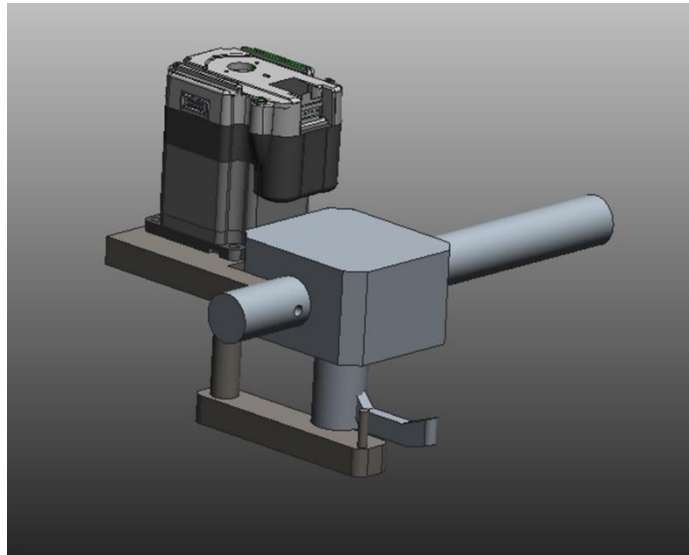

Figure 18 – Mounting for stepper motor. Manufactured parts are shown in dark brown coloring

Ongoing Work

Currently, to date, the 23 M-Drive stepper motor is next in line to be ordered. All mounting material is in stock and mounts are ready to be machined. The lead time for this motor will take at most three weeks. The motor will arrive at the start of spring semester which is right on schedule. Mount and installation should be done no later than mid-January.

Work for the Spring Semester

Mount, install and test stepper motor.

Mount Material Selection

For selection of mounting material, careful consideration was taken to account for the life span of this project and also the environments at which this project will operate in. We want to maximize the reliability of all aspects of this project, thus we want to select material that will not fail under any operating circumstance. Also, we considered that the material selected might be exposed to corrosive elements such as water or humidity. After careful research, we concluded that stainless steel was the best option. Stainless steel not only is corrosive resistance but is also stronger than 2024 aluminum (Brandt, Warner). The following figure compares multiple metals in a stress vs. strain graph. Clearly stainless steel is the best material for our application.

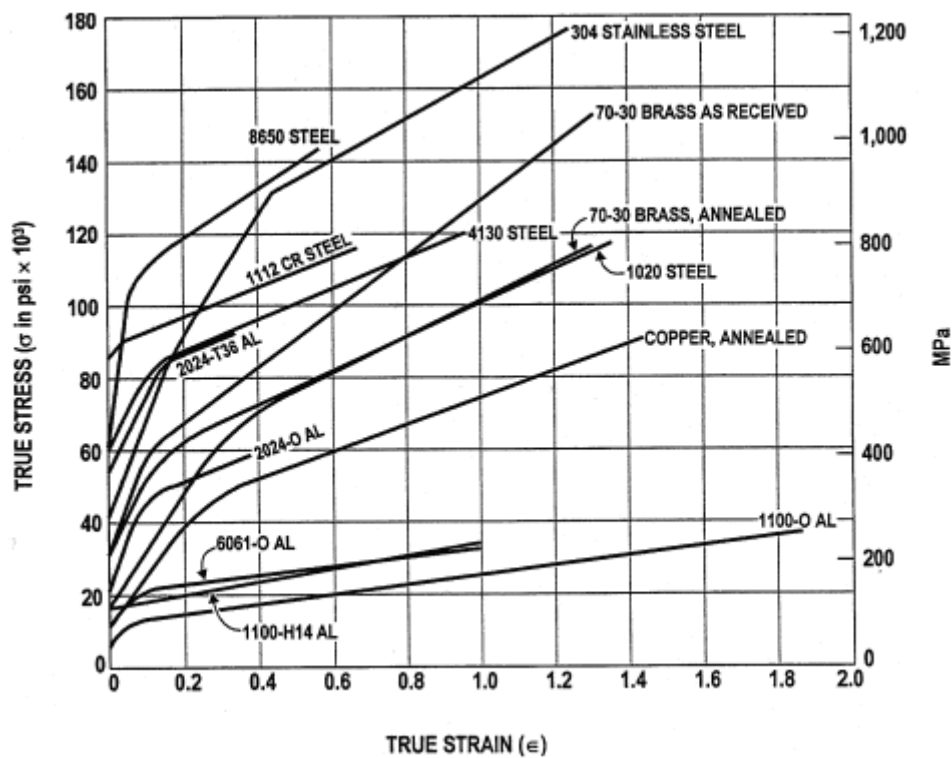

Figure 19 – Stress vs. Strain graph of multiple metals

Cost Analysis

The table below shows the current cost estimate for the completion of this project. The budget for this project is entirely provided by the project sponsor, CISCOR. Our current budget from CISCOR is \$5,000. Our final cost estimate is \$4,175 which is within our budget. Much of the budget will be used to purchase the components to successfully automate the vehicle. A smaller portion will be used to buy the mounting materials, such as aluminum, and the plastic to protect the locomotion components and improve the aesthetics of the overall vehicle. The rest of the budget will be reserved for unanticipated costs that may arise during construction and mounting of the various components during the spring semester.

Components	Cost	Quantity	Total Cost
Throttle Stepper Motor	450	1	450
Gear Shift Linear Actuator	670	1	670
Braking Linear Actuator	590	1	590
Steering Motor	2,000	1	2,000
Brake Line Pressure Transducer	225	1	225
Aluminum Stock (Plate and Rods)	120	n/a	120
Mounting Hardware (Bolts, Nuts, etc.)	40	n/a	40
Plastic (Aesthetics and Casing)	80	n/a	80
Total Cost of Project			\$4,175

Table 1 – Budget breakdown

Safety Consideration

Safety is top priority on this project. With a top speed exceeding 60 mph and a weight of 700 pounds, GOLIATH is no small robot. Mechanical fail safes, electrical kill switches and redundancies have to be implements to ensure the safety of working personnel as well as the safety of GOLIATH. With this in mind, a safety supervisor position was created at the conception of this project in early Fall 2012. The safety supervision will ensure the safety of the project members during the construction and the operation of the vehicle. The safety coordinator will also ensure that non-group members are not endangered during the operation of the vehicle.

The following rules and regulations were implemented from the start of this project:

1. Only authorized personnel can operate vehicle
2. Authorized personnel operating the vehicle must wear appropriate safety equipment
 - a. DOT approved helmet
 - b. Close toed shoes
 - c. Long pants
 - d. Gloves
3. While making modification the vehicle must be in the PARK position with the engine OFF and battery UNPLUGGED
4. All flammable liquid must be kept in SAE approved flammable liquid receptacles
5. All toxic liquids must be disposed of in a safe and legal manner
6. No outside night time operation of vehicle

The following safety mechanisms are to be installed no later than January 15, 2013:

1. Four manual kill switch relays
2. Two remote RF-band kill switch relays
3. One high visibility caution light
4. Mechanical stop plugs on each locomotion mechanism

No unmanned testing will occurring until these parameters are met and safety equipment installed.

Environmental Consideration

Environmental safety is also a top priority for this group. Before purchasing and acquiring our all-terrain vehicle platform, we ensure that the vehicle complied with both federal and state laws for gas emissions. GOLIATH has a 550 cc gasoline powered engine, and thus releases CO₂ gas emissions during operations. However, GOLIATH's manufacture, Polaris claims it has the lowest emissions and green house effects for its class ("Polaris Sportsman 550")

Furthermore, all hazardous liquids are disposed of in safe, dedicated waste receptacles. We follow all local, state and federal laws to ensure proper hazardous waste disposal.

Conclusion

In conclusion, designs for GOLIATH's locomotion mechanism have been finalized. Motors and supplemental components have been ordered. All aspects of this project are proceeded on time if not ahead of schedule. At the end of spring semester, we are very confident that this project will be finalized and ready for delivery to CISCOR.

References

Brandt, Daniel A., and J. C. Warner. Metallurgy Fundamentals. Tinley Park, IL: Goodheart-Willcox, 2009. Print.

"DARPA Learning Applied to Ground Robots (LAGR) Project (Concluded)." DARPA Learning Applied to Ground Robots (LAGR). N.p., n.d. Web. 07 Dec. 2012.

"FAMU-FSU College of Engineering :: CISCOR Center for Intelligent Systems, Control and Robotics." FAMU-FSU College of Engineering :: CISCOR Center for Intelligent Systems, Control and Robotics. N.p., n.d. Web. 05 Dec. 2012.

"Sportsman[®] 550." 2013 Polaris Sportsman 550 Sage Green ATV: Features. N.p., n.d. Web. 07 Dec. 2012.

Appendix A – Engineering Drawing of Parts

Connector Rod

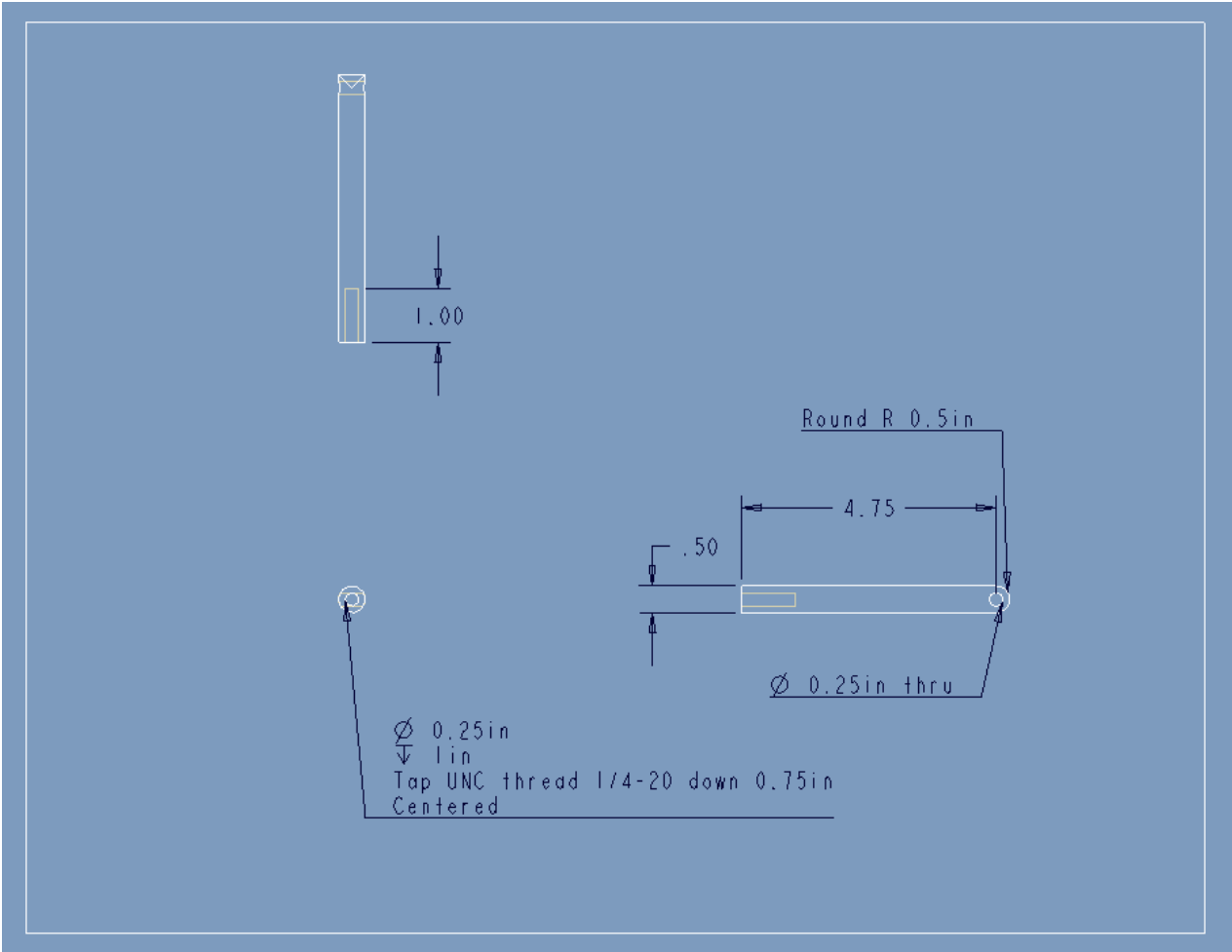

Pin Block

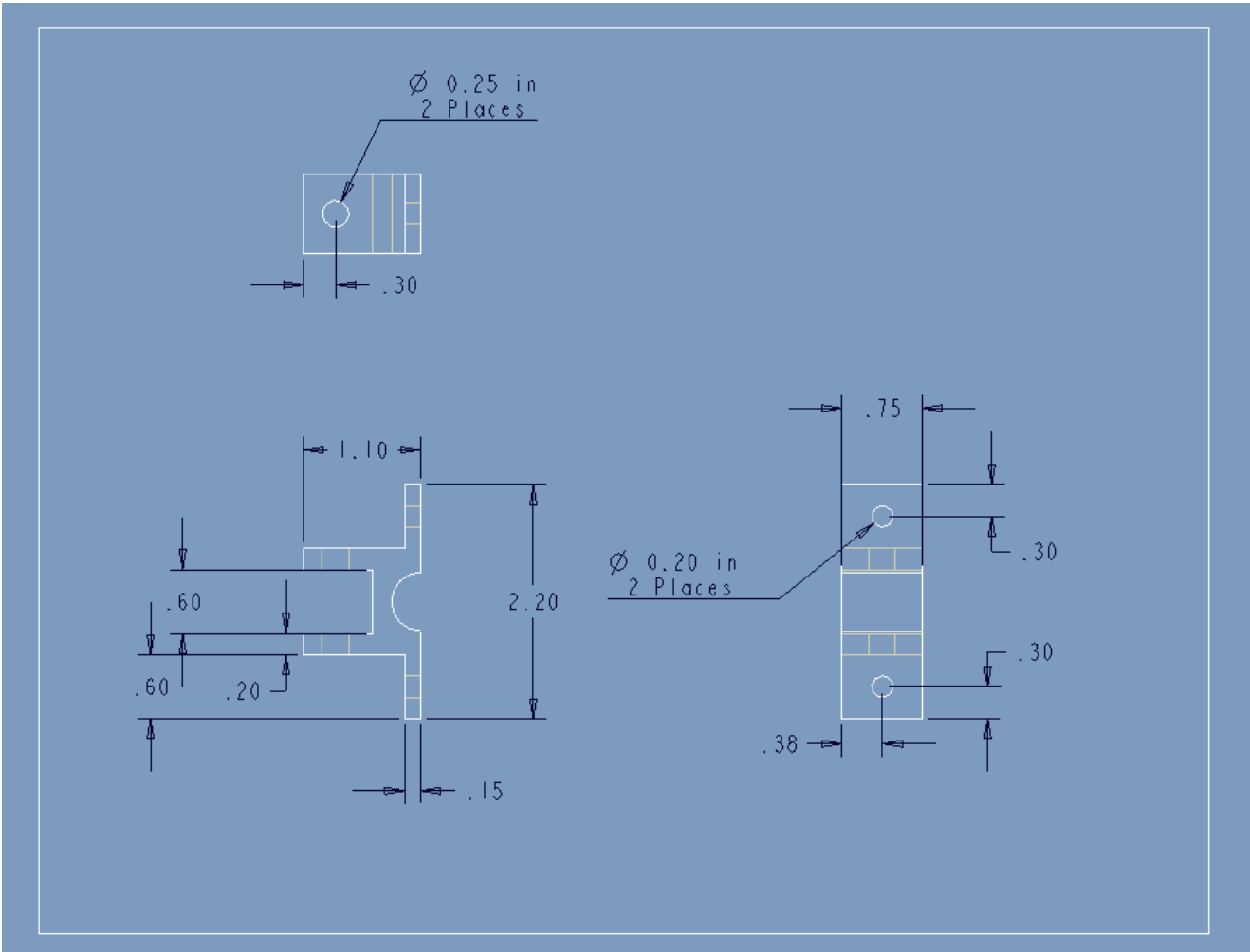

Pin Block 2

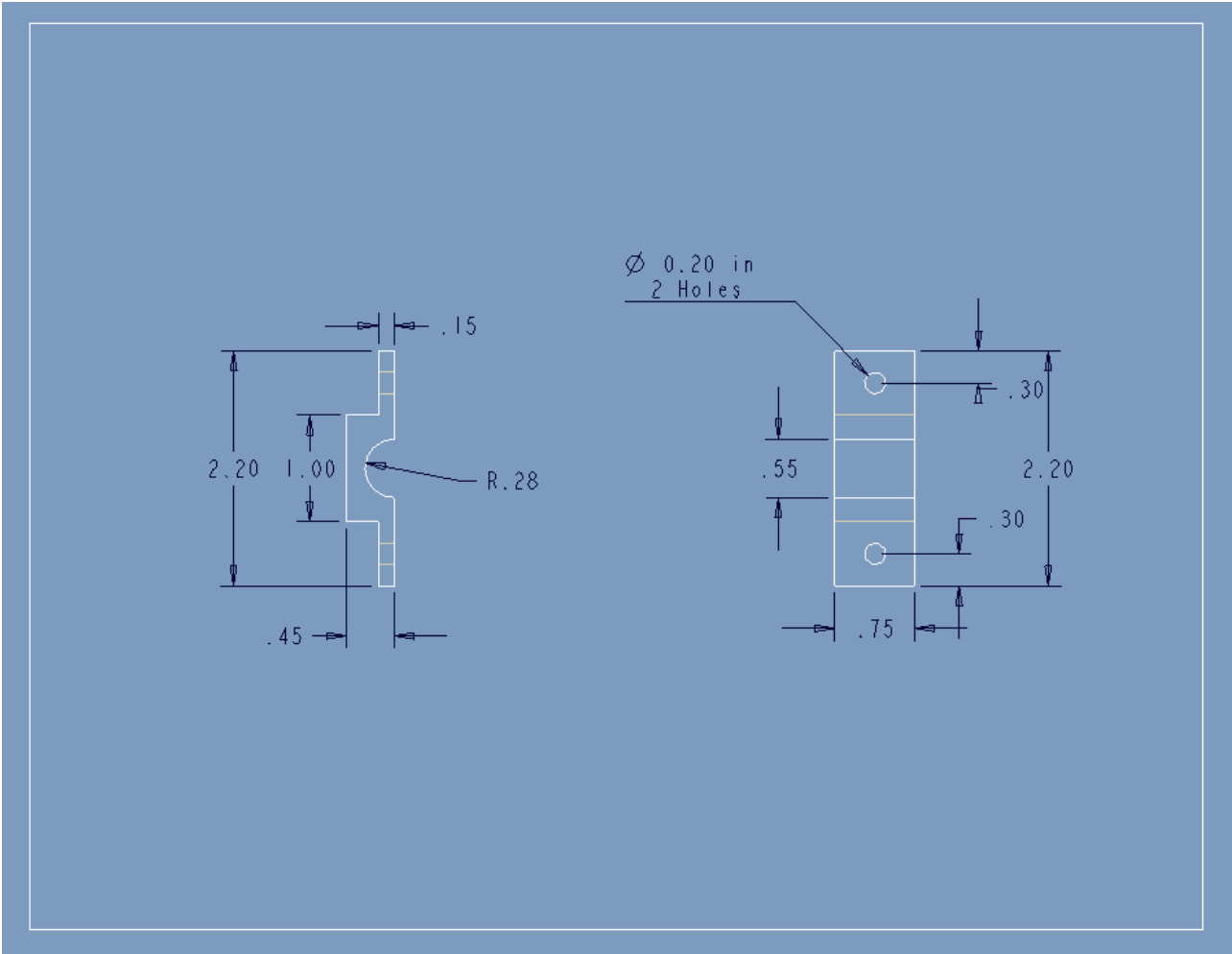

Base Mount

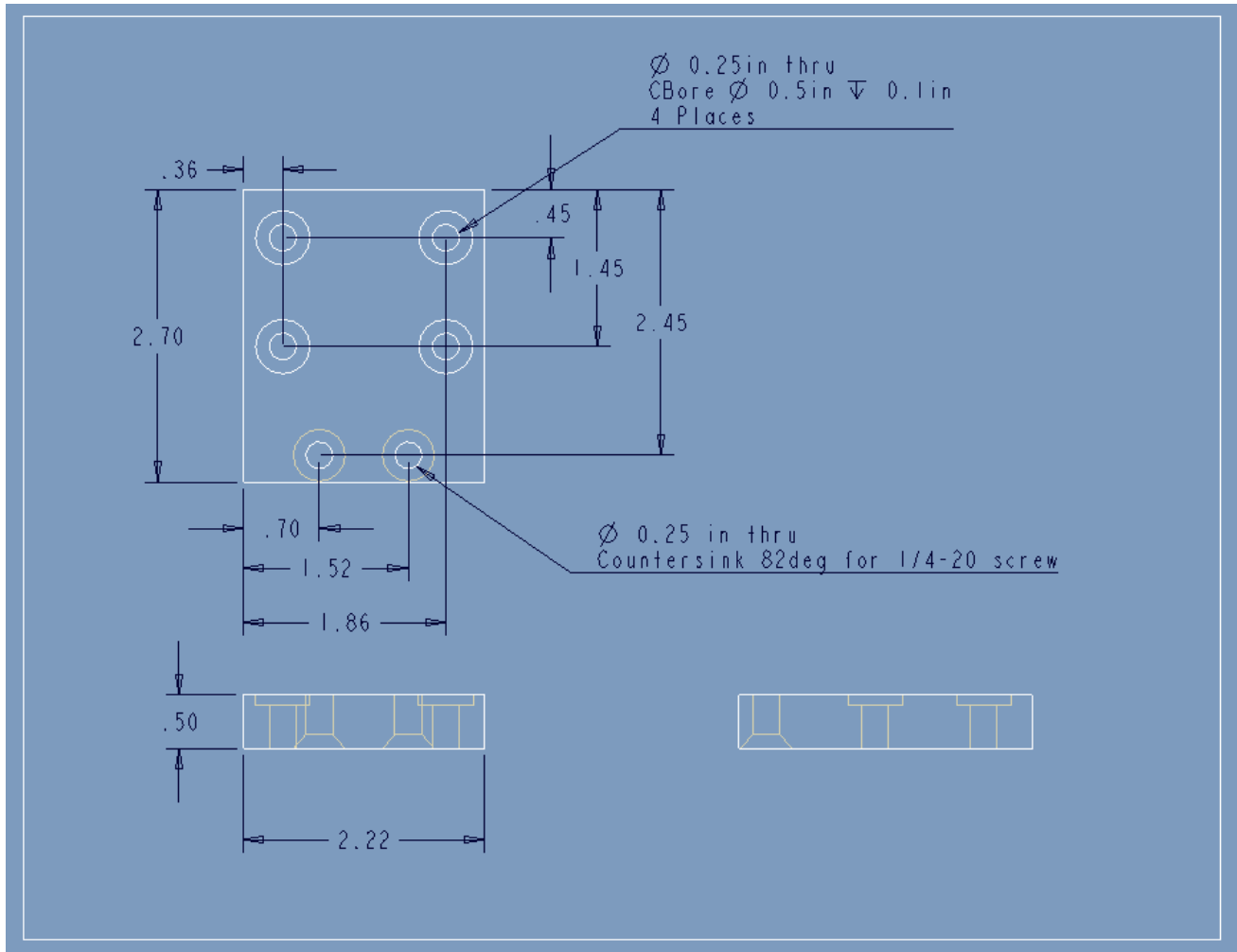

Support Mount

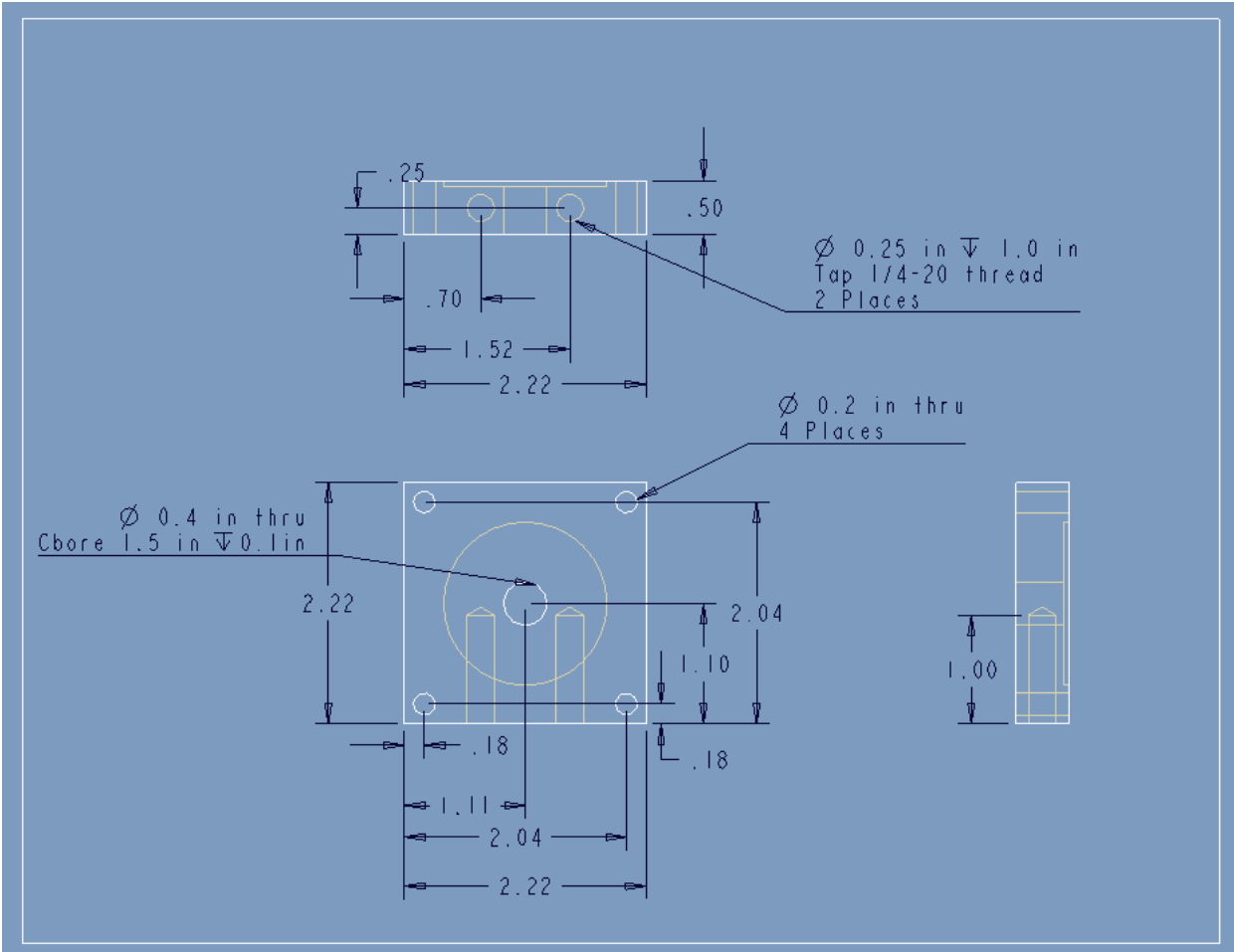

Brake Mounting Plate

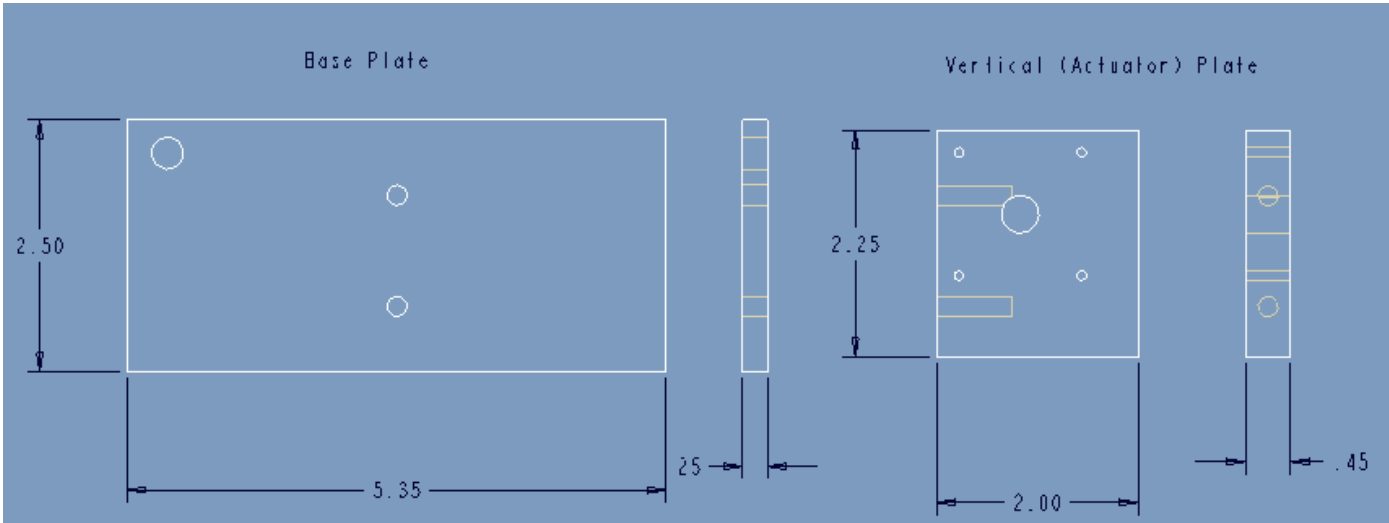

Modified Brake Lever

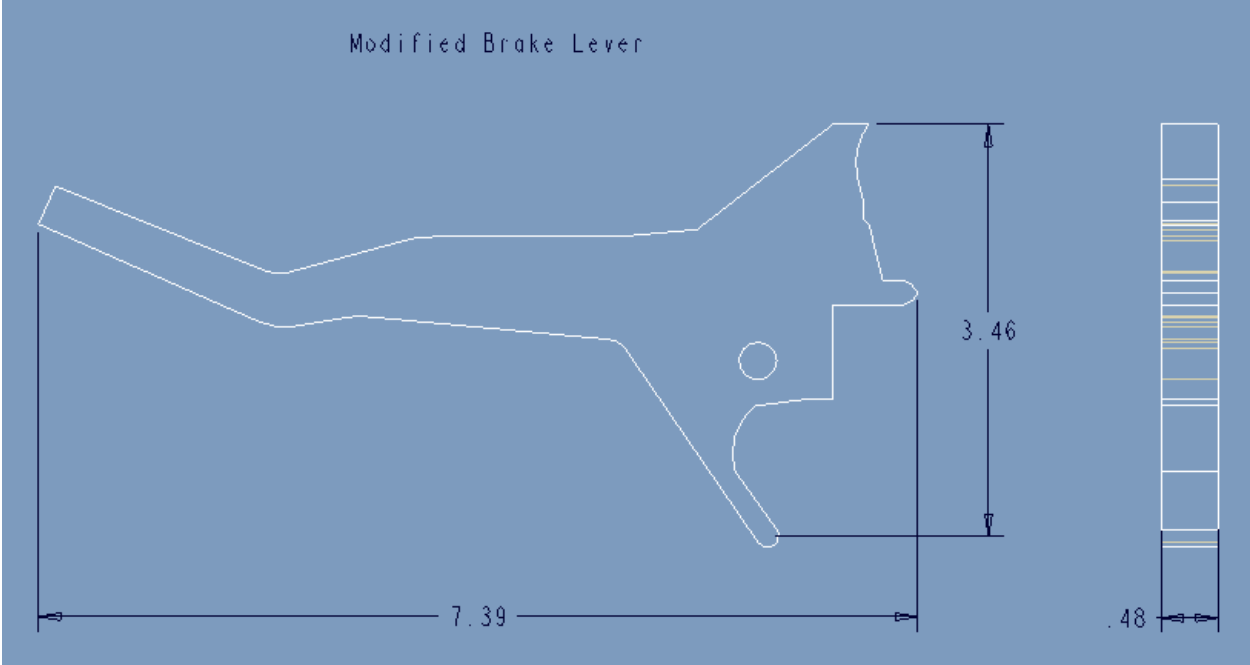

Appendix B – Component Dimensions

Schneider Electric 17 M-Drive Linear Actuator

Dimensions in inches (mm)

Non-captive shaft

Side view

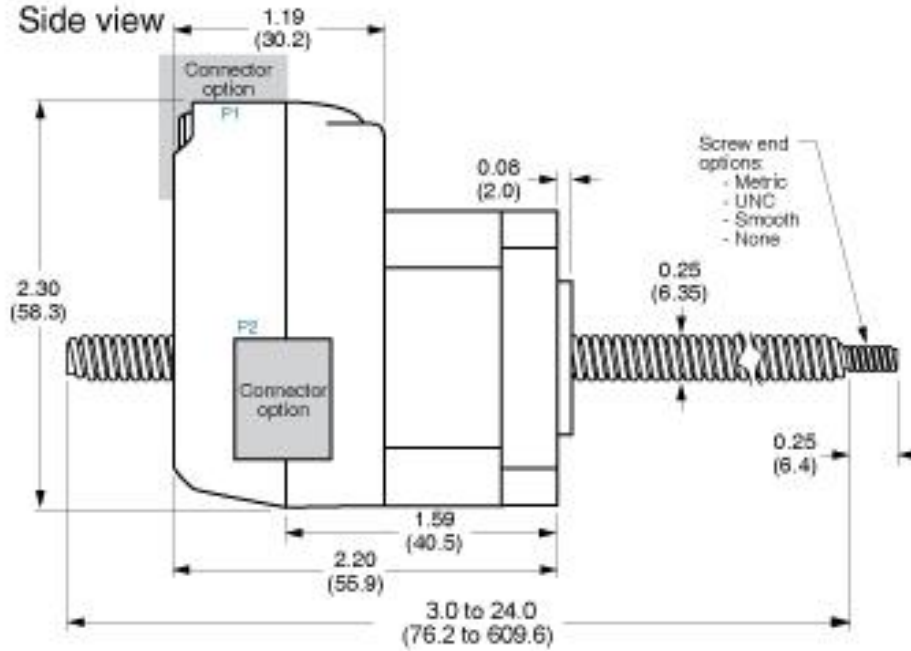

Front view (same for both)

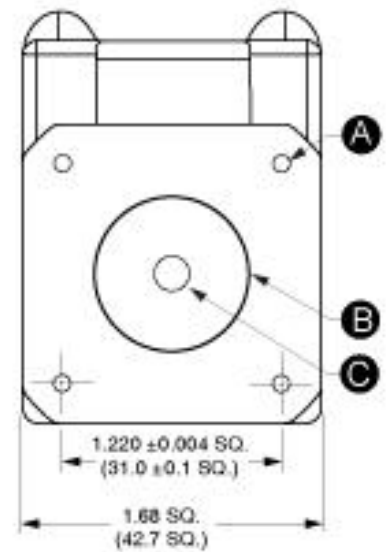

Schneider Electric 23 M-Drive Linear Actuator

Non-captive shaft

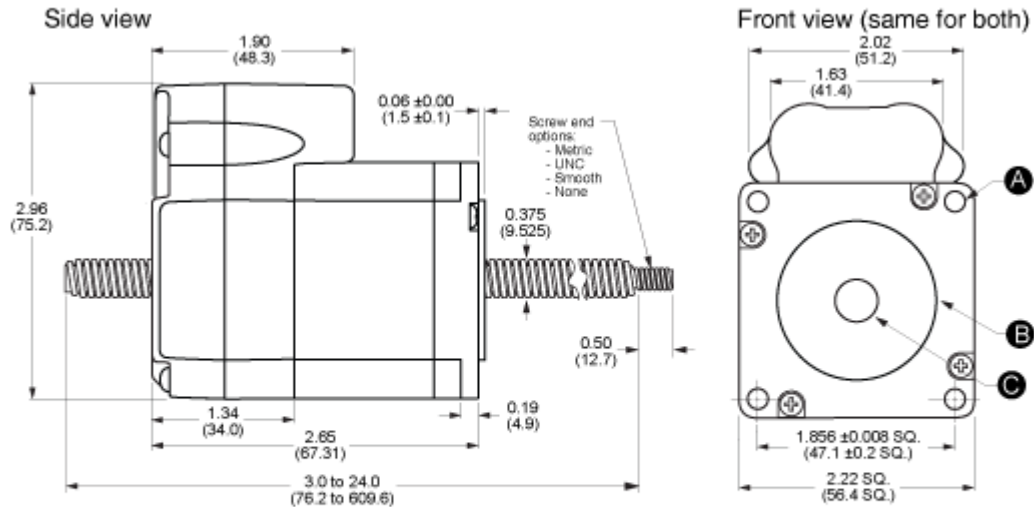

- A** 4X Ø 0.197 (Ø 5.0) THRU
- B** Ø 1.500 ±0.002 (Ø 38.1 ±0.1)
- C** Screw end options, see leadscrew specs

External shaft

Side view

1.90

Schneider Electric 23 M-Drive Stepper Motor

Dimensions in inches (mm)

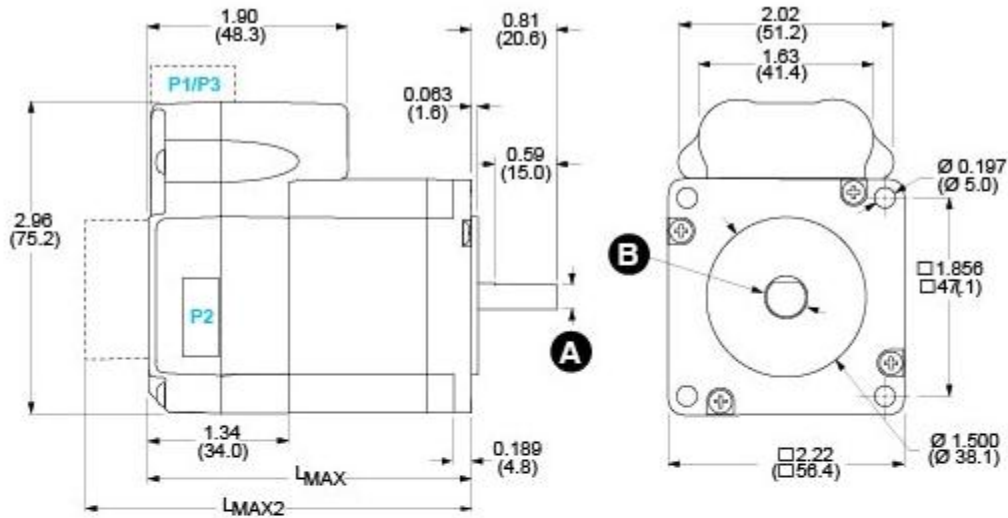

Motor stack length	L _{max} (1)	L _{max2} (2)
Single	2.65 (67.31)	3.36 (85.34)
Double	3.02 (76.71)	3.73 (94.74)
Triple	3.88 (98.55)	4.59 (116.59)
Quad	5.28 (134.15)	5.99 (152.19)

(1) Single shaft or internal encoder.
 (2) Control knob or external encoder.

L_{max2} option

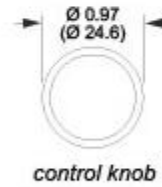

A Single, Double & Triple Length Motors:
 0.230 ±0.004
 (5.8 ±0.1)
 Quad Length Motor:
 0.2756 ±0.004
 (7.0 ±0.1)

B Single, Double & Triple Length Motors:
 Ø 0.2500 +0/-0.0005
 (Ø 6.350 +0/-0.013)
 Quad Length Motor:
 Ø 0.315 +0/-0.0005
 (Ø 8.0 +0/-0.013)

Appendix C – Equations

Equations 1:

Torque = Force * Perpendicular Distance

