

Design for Manufacturing, Reliability, and Economics

EML 4551C – Senior Design – Spring 2013 Deliverable

Team 13: Smart Materials Museum Exhibit Design

Glen Ashworth, Laura Wainikainen, Daniel Roque, and Isaac Piersall
Department of Mechanical Engineering, Florida State University, Tallahassee, FL

Project Sponsor

Challenger Learning Center



Project Advisor:

Dr. William S. Oates, Ph.D.

Department of Mechanical Engineering

Table of Contents

A	<i>Prototype Design and Components to be Manufactured</i>	
A-1	Material Selection	pg. 2
A-2	B.O.M., Blueprints, Design	pg. 3
A-3	Assembly Drawings, Instructions	pg. 8
A-4	Challenges Encountered	pg. 9
B	<i>Design for Reliability</i>	pg. 10
B-1	Safety	pg. 10
B-2	Alignment	pg. 10
B-3	Electronic Components	pg. 10
C	<i>Design for Economics</i>	pg. 11

A Prototype Design and Components to be Manufactured

A-1 Material Selection

- M4010-P1 2 x \$60 = \$120
 - D33 type elongator
 - based on code provided by mike hayes that predicted the tip displacement/angle we choose the size MFC actuator that provided adequate angular displacement
 - operates from -500v to +1500v
- Emco C10, 2 for \$250
 - regulated 1 watt amplifier 0-1000v
 - chosen to provide a safety factor for operating the piezo
- Arduino Uno, 2 x \$30 = \$60
 - inexpensive, and suitable for our application
 - multiple analog to digital inputs and pwm outputs and plenty of additional digital pins for adding switches
- Servos 2 x \$9 /pan-and-tilt \$6, total \$24
 - inexpensive 2D motion generation only needed to be able to move a laser pointer
- photoresistors 4 x \$1.50 = \$6
 - needed to create a laser sensor
- lasers \$20
 - inexpensive low power lasers
- joystick \$15
 - digital pushbutton joystick
 - inexpensive durable construction, meet for arcades
- capacitor \$2 /resistors \$0
 - used to make a RC low pass filter
 - resistors used also as pull down resistors for switches
- arcade buttons 4 x \$2.50
 - inexpensive durable switches
- wood for display \$0
 - inexpensive building material already on hand
- acrylic \$0
 - provided by challenger learning center
 - used to protect display and incase the high voltage components
- helping hands 2 x \$17 = \$34
 - used as an adjustable stand for holding piezos and laser
- epoxy \$25
 - used to glue piezos to stainless steel
 - suggested by mike hayes, used on previous experiments
- 303 stainless steel 2 x \$0
 - 2.2 mm thick
 - leftover material from previous experiments performed by Mike Hayes

A-2 B.O.M., Blueprints, Design

Bill of Materials

	ITEM	DESCRIPTION	QUANTITY	COST	Total Cost
User Interface	Piezoelectric Material	Smart Material Corp	2	\$ 58.00	\$ 116.00
	Laser	5 mW Green	2	\$ 30.00	\$ 60.00
	Power Source	12 V 2A DC	1	\$ 10.50	\$ 10.50
	Laser/Piezo Stand	SE MZ101B Helping Hands	2	\$ 8.00	\$ 16.00
	Microcontroller	Arduino Uno	2	\$ 29.95	\$ 59.90
	Amplifier	EMCO-C10	2	\$ 170.00	\$ 340.00
	Small Mirrors	Micheal's	1	\$ 4.00	\$ 4.00
	Joystick	Arcade Joystick-Short Handle	1	\$ 14.95	\$ 14.95
	Exhibit Stand	Wood	1	\$ 50.00	\$ 50.00
	Exhibit Case	Acrylic	1	Provided by Sponsor	\$ -
Satellite Target	Pan/Tilt Kit	ROB-10335	1	\$ 5.95	\$ 5.95
	Small Servo Motor	ROB-09065	2	\$ 8.95	\$ 17.90
	Target	Craft Materials	1	\$ 10.00	\$ 10.00
	Mock Satellite	Craft Materials	1	\$ 25.00	\$ 25.00
	Photocell (.43" thick)	Jameco Part no. 120299	4	\$ 7.16	\$ 28.64
	Op Amp (LM358)	Jameco Part no. 120862	2	\$ 0.50	\$ 1.00
	Comparator (LM393)	Jameco Part no. 24281	2	\$ 0.50	\$ 1.00
				\$ 760.84	

Figure 1: Bill of Materials

Blueprints

Most of our parts were bought already made. There was no need to manufacture them. However, some parts, such as the pan and tilt kit, stand, and acrylic casing has to be assembled. The following are blueprints for those three items.

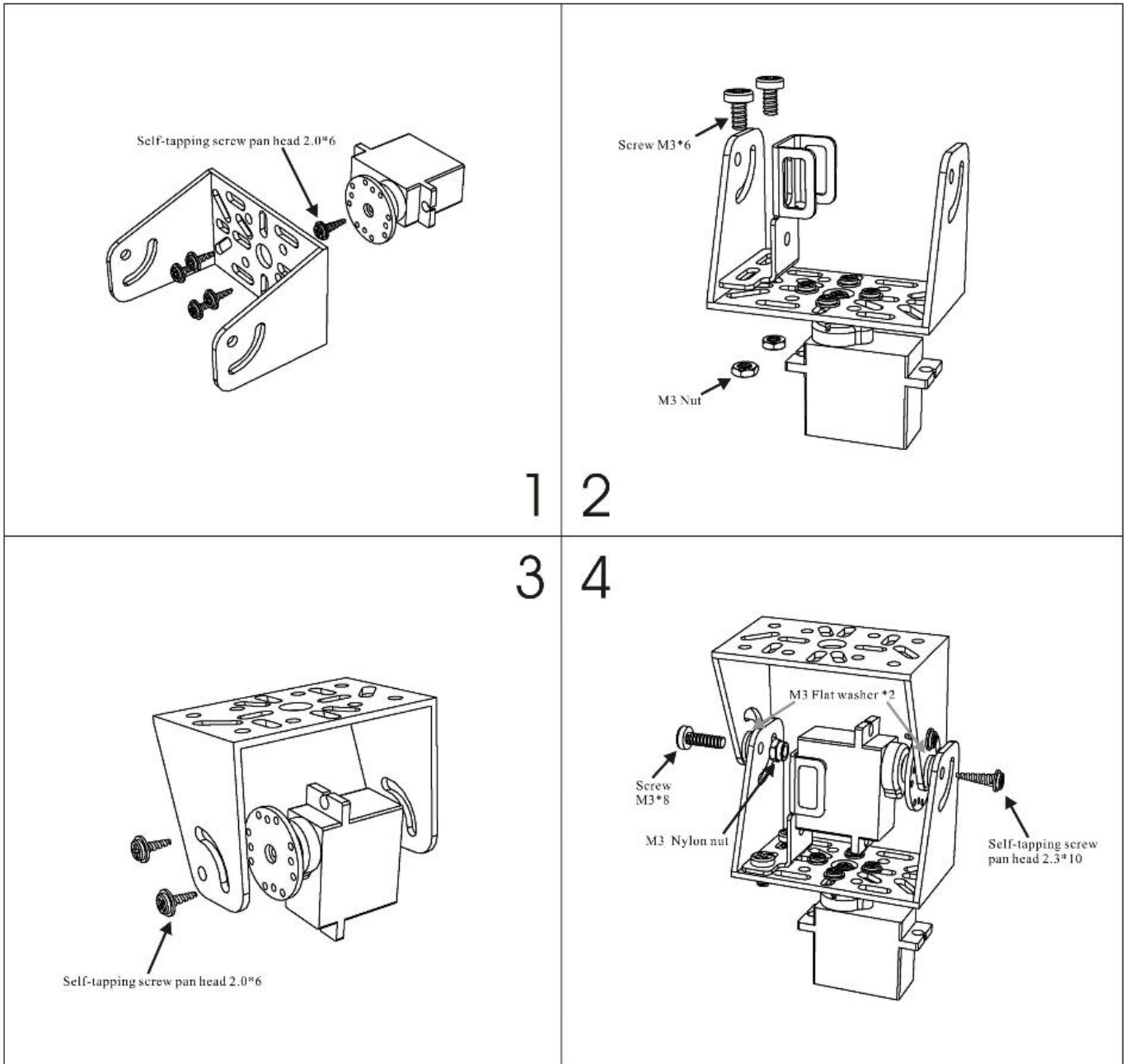
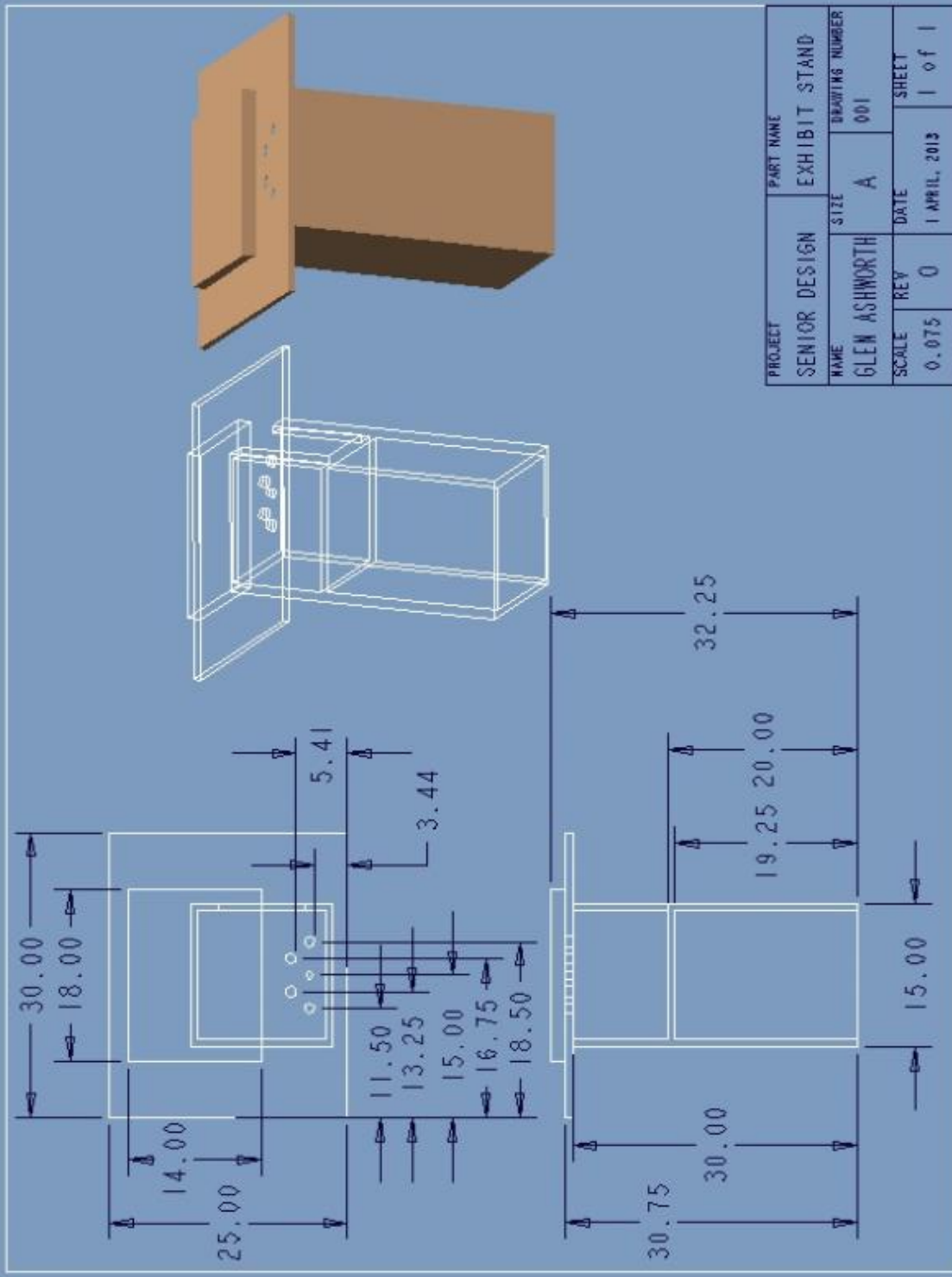

Figure 2: Pan and Tilt Kit



PROJECT	PART NAME		DRAWING NUMBER	
SENIOR DESIGN	EXHIBIT	STAND	SIZE	DATE
NAME	GLEN	ASHWORTH	A	001
SCALE	REV	0	DATE	1 APRIL, 2013
0.075			SHEET	1 of 1

Figure 3: Exhibit Stand

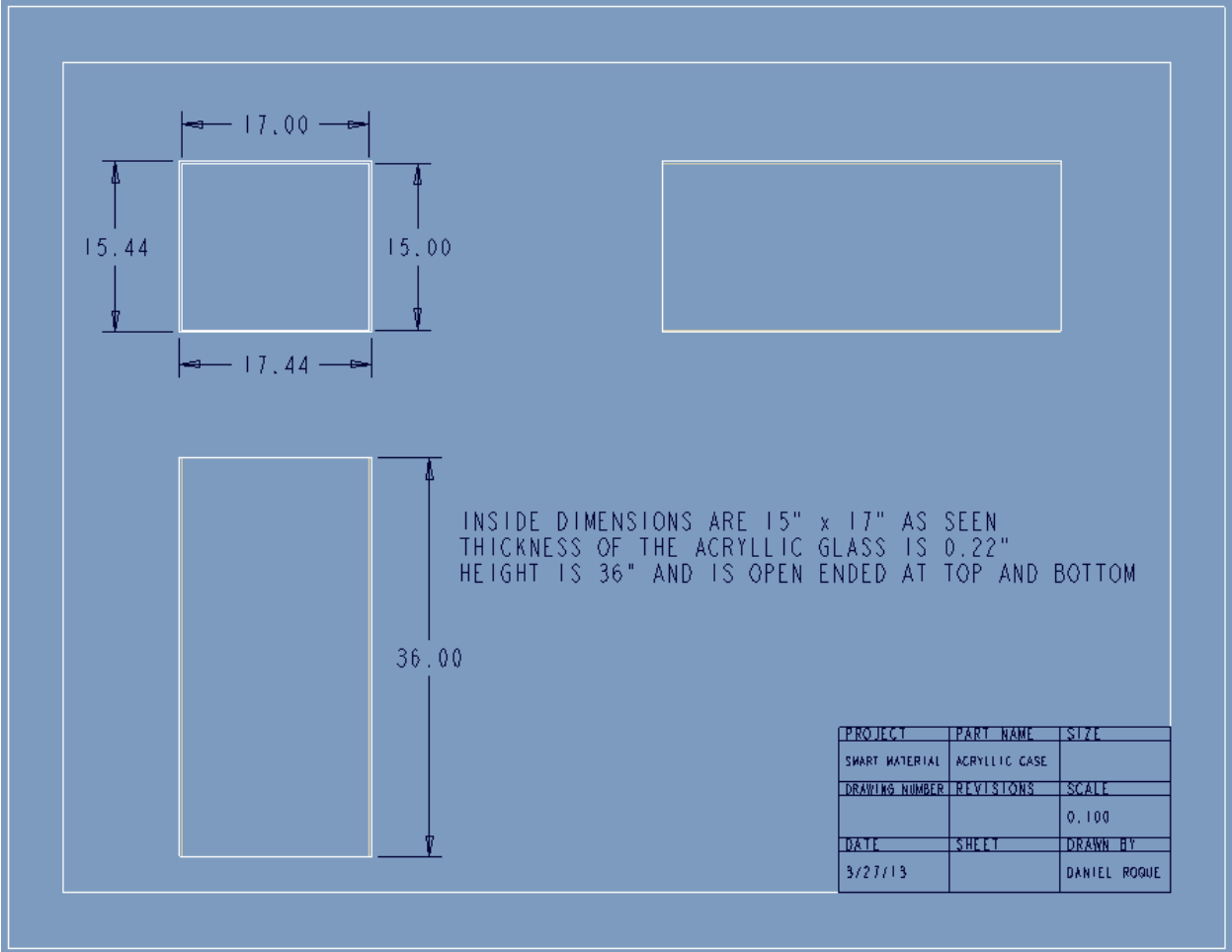

Figure 4: Acrylic Casing

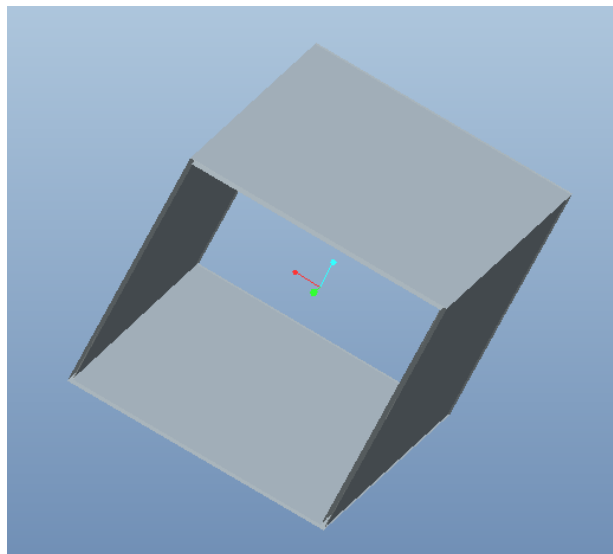

Figure 5: Acrylic Casing

Design

The design, explained briefly, works in the following manner. The user or student controls the voltage that the peizos are given via the joystick. When voltage is provided to the peizos, they bend slightly. A laser which is turned on once the joystick is moved, reflects a laser beam off the small mirrors which are situated on the same thin metal sheet as the peizos. Students will adjust the voltage given so that the reflected laser will hit one of the four photoresistors that are planted on the target above. Once a student hits one of the photoresistors with the laser, a pan and tilt kit adjusts accordingly. This pan and tilt kit is situated inside a mock satellite. After the photoresistor is hit, the mock satellite “adjusts” and another laser is turned on and its projected onto the Florida map.



Figure 6: Lobby View

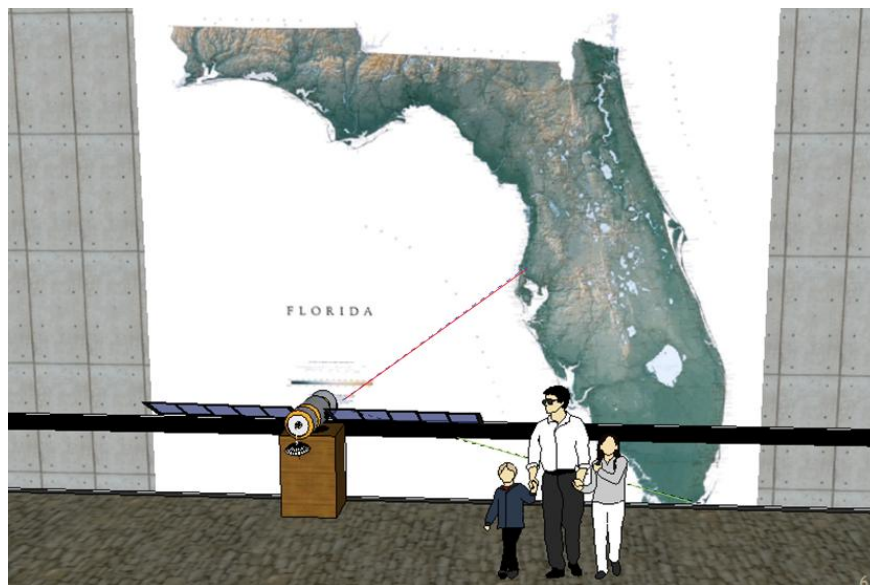

Figure 7: View From Balcony

A-3 Assembly Drawings, Instructions

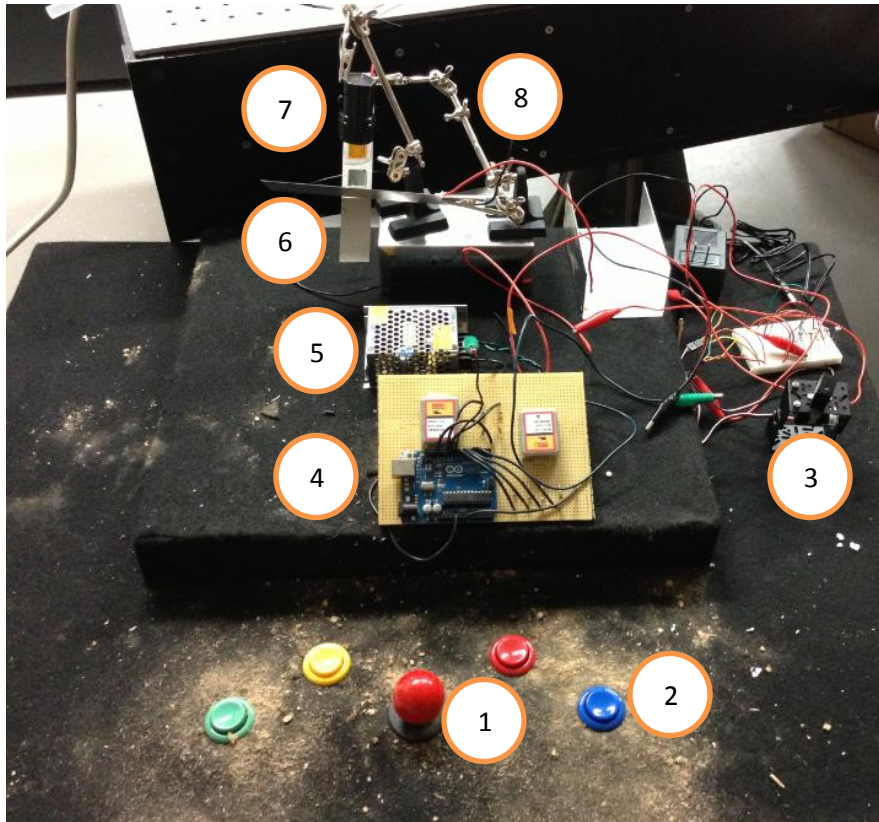

Figure 8: Assembly

Figure 8 is what our stand looks like minus the acrylic casing. Each material has its own respective number which will be identified and explained.

- 1) This is the joystick that provides the voltage to the piezoceramics. Voltage is given in intervals as the user moves it to the left, right, up or down.
- 2) This button will simply provide a demonstration of how the piezos move when given voltage. It is not a part of the interactive design. It is more of a bonus added feature.
- 3) This is our pan and tilt kit. It is activated once a photoresistor is hit with laser.
- 4) This is our arduino. It has the coding which allows the joystick and piezos to work together.
- 5) This is simply our power supply to power our design.
- 6) These are the metal sheets which have the piezos and small mirrors attached.
- 7) This is our laser which will be reflected off the mirrors attached to the metal sheet.
- 8) This is the setup which holds the metal sheets containing the piezos and mirrors.

A-4 Challenges Encountered

One large challenge we faced was positioning the piezoelectric material. The positioning had to be extremely stable and precise; a fraction of a degree or millimeter off drastically changes the final position of the laser. Precise machining of a rigid mounting setup was considered, but this would take considerable time to do and there would be a large chance that any miscalculation or mistake made in the machining or dimensioning process would result in an unusable setup. To avoid the limitations of a traditional rigid mounting setup, an easily movable, adjustable stand was conceived. Luckily, there already existed such a product on the market for a very low cost. The cost was far less than the cost of machining and materials would be for a custom mounting setup. This adjustable stand with multiple degrees of freedom, called “Helping Hands”, is usually used to hold components while soldering. This device worked perfectly for our application, and can easily be adjusted depending upon the final orientation desired.

Another challenge we faced was the lack of an analog output on our Arduino microcontroller. To rectify this, we simply employed the use of a low pass filter. This low pass filter modified the PWM signal from the microcontroller so that it simulated an analog output.

B Design for Reliability

B- 1 Safety

Since this project will be used by the public in the Challenger Learning Center safety played a major role in our design. The project incorporates laser lights and has many electrical components that could be hazardous. To ensure the safety of everyone using this project a limit was put into the coding of both of the arduinos. The first arduino is used to aim the first laser beam at the photocell array. The photocells are approximately 5 mm in diameter so the displacement of the laser light can be limited to a very small window. The second laser will shine across the room onto a large map. This laser was placed high above eye level and the displacement of this laser was also limited so there is no possibility of it shining into a person's eyes. Safety measures were also taken to ensure that all the electrical components were stored away. The electrical wiring is all encased inside the exhibit stand and a vent was installed to prevent overheating.

B-2 Alignment

To receive the proper laser light displacement it is necessary to have the proper alignment of each component upon installation. To do so, a sturdy exhibit stand was designed that will not allow movement of the user interface. The laser, amplifiers, piezoelectric ceramics, and joystick are installed here. The placement of the piezoelectric ceramics is determined to ensure the laser light is reflected toward the photocell array. At the target a second laser is rigidly mounted onto a pan/tilt kit with servo motors for control. This second laser is aimed at the map across the room and its movement is limited with an arduino.

B-3 Electronic Components

The original design used a voltage divider to limit the voltage being fed from the arduino to large (C80) amplifiers. To increase the reliability of the system, the design was changed to incorporate smaller amplifiers (C10) and an RC filter. The RC filters are use do smooth the PWM signal to create an analog voltage. The RC filters are placed between the arduino and the amplifiers. With this design the arduino is capable of powering the C10 amplifiers which will then power piezoelectric ceramics.

C Design for Economics

Our project was very broad in the sense that there was no specific direction in which way to go about our design. Our problem statement was simply to design, build, and test a museum exhibit that incorporated and demonstrated how smart material works. Being that our design was quite open ended; we initially had no idea for what our components would include. As our ideas and design started to be put together, we began to think economically.

We received a grant from NASA along with some funding by Dr. Oates which was greatly appreciated. Once we knew the allotted amount, we began looking for specific components that would perform the requirements we needed as well as fit comfortably within our budget. We took a certain approach to make certain no parts went wasted and we used minimum money.

We were all new to the concept of smart materials and their behavior so we were not entirely sure how they would behave. We had an idea from the research we conducted but we had no means to know if it would work as we planned it to with our design. Therefore we conducted testing with piezoceramics that Dr. Oates already had. We also used some of his components for our testing of the piezos. This was all done with the proper reasoning that if it worked as we intended, then we would go ahead and make the necessary purchases and if it didn't work as we thought, we would then alter our design. Using Dr. Oates's piezoceramics and electrical components, our testing was a success as it all behaved as we figured. Knowing our design would function as we pleased, a bill of materials was put together and purchases were made.

This bill of materials included parts that we would need for our experiment. Again, cost was always a factor throughout the process of our project. We did not include all parts as we decided some parts could very well be built by ourselves. We took matters into our own hand with the construction of the stand where the piezoceramic setup with joystick would be. This proved to be much less costly than having a third party build our stand. An acrylic case was also necessary to enclose our piezo setup. This was quite costly. Therefore, we contacted our project sponsor and they were generous enough to donate it. As mentioned previously, we thought economically in every aspect of our project. No parts went wasted and we were able to assemble it all while falling within our budget.