

**FAMU-FSU College of Engineering**  
**Department of Electrical and Computer Engineering**

**PROPOSAL**

**ECE-ME Senior Design Project**

**Project title: Cosmic Cube**

**Team: #4**

**Team Members:**

**Matt Gibson**, Electrical Engineering (Email: [mrg02d@my.fsu.edu](mailto:mrg02d@my.fsu.edu))

**Cole Gray**, Mechanical Engineering (Email: [cdg10c@my.fsu.edu](mailto:cdg10c@my.fsu.edu))

**Crystal Hill**, Mechanical Engineering (Email: [cxh09@my.fsu.edu](mailto:cxh09@my.fsu.edu))

**Don Lundi**, Electrical Engineering (Email: [drl07c@my.fsu.edu](mailto:drl07c@my.fsu.edu))

**Kenneth Spradley**, Electrical Engineering (Email: [kenneth1.spradley@fam.u.edu](mailto:kenneth1.spradley@fam.u.edu))

**Senior Design Project Instructor:**

**Dr. M. Frank**

**Technical Advisors:**

**Dr. O'Neal**

**Dr. Hollis**

**Reviewers**

**Dr. Perry**

**Dr. Weatherspoon**

## List of Revisions

Date	Revision	Comments
10/12/2012	1	Original Document
10/15/2012	2	Added Acknowledgements
10/16/2012	3	Added References and Statement of Work
10/17/2012	4	Added Formatting/Additional Documentation

## Table Contents

1. Project Executive Summary .....	4
1.1. Project Description.....	4
1.2. The Team.....	4
1.3. Target Market.....	4
1.4. Funding.....	5
1.5. Summary.....	5
2. Introduction .....	6
2.1. Acknowledgements.....	6
2.2. Statement of Problem .....	6
2.3. Operating Environment .....	6
2.4. User Environment.....	6
2.5. Intended Use(s) and User(s) .....	7
2.6. Assumptions and Limitations.....	7
2.6.1. Assumption.....	7
2.6.2. Limitation.....	7
3. Proposed Designs .....	8
3.1. Overview .....	8
3.1.1. Scintillator.....	11
3.1.2. Photo-detector.....	11
3.1.3. Microcontroller/CPU.....	11
3.1.4. Global Position System (GPS).....	12
3.1.5. Wi-Fi.....	12
3.1.6. Structure.....	13
3.1.7. Light Emitting Diode.....	13
3.1.8. Radioactive Isotope.....	13
4. Statement of Work (SOW).....	15
4.1. Task 1: Project Management.....	15
4.2. Task 2: Preliminary Design and Development.....	15
4.2.1. Subtask 1: Identify & Prepare Sensor.....	15
4.2.1.1. Objective.....	15
4.2.1.2. Approach.....	15
4.2.1.3. Test/Verification Plan.....	16

4.2.2. Subtask 2: Identify & Prepare Microcontroller .....	16
4.2.2.1. Objective .....	16
4.2.2.2. Approach.....	16
4.2.2.3. Test/Verification Plan.....	17
4.2.3. Subtask 3: Identify & Prepare Wi-Fi.....	17
4.2.3.1. Objective .....	17
4.2.3.2. Approach .....	17
4.2.3.3. Test/Verification Plan .....	17
4.2.4. Subtask 4: Identify & Prepare GPS.....	17
4.2.4.1. Objective .....	17
4.2.4.2. Approach .....	17
4.2.4.3. Test/Verification Plan.....	18
4.2.5. Subtask 5: Choose Isotope.....	18
4.2.5.1. Objective .....	18
4.2.5.2. Approach .....	18
4.2.5.3. Test/Verification Plan .....	18
4.2.6. Subtask 6: Design & Construct Structure.....	18
4.2.6.1. Objective .....	19
4.2.6.2. Approach.....	19
4.2.6.3. Test/Verification Plan.....	19
4.2.7. Subtask 7: Power Supply Unit (PSU).....	20
4.2.7.1. Objective.....	20
4.2.7.2. Approach.....	20
4.2.7.3. Test/Verification Plan.....	20
5. Risk Assessment .....	21
6. Qualification and Responsibilities of Project Team.....	21
6.1. Qualifications of Matthew Gibson.....	21
6.2. Qualifications of Cole Gray.....	21
6.3. Qualifications of Crystal Hill.....	22
6.4. Qualifications of Don Lundi.....	22
6.5. Qualifications of Kenneth Spradley.....	22
7. Schedule.....	24
8. Budget.....	24
9. Deliverables.....	25
10. References.....	26
11. Appendices.....	27

# **1. Project Executive Summary**

## **1.1. Project Description**

Cosmic radiation is generated by interstellar bodies such as stars when they undergo a supernova event. The rays produced travel throughout the universe, largely unimpeded. Because of the extraordinary power of such cosmic events, the resultant rays are highly energetic. When one of these rays hits Earth's atmosphere, a shower of particles is produced that continues to the surface. Some common particles that make it through our atmosphere are: muons, protons, electrons, and neutrons. By understanding when and where these particles come from, it allows for a better comprehension of the forces that shape our universe.

The cosmic particles that are of interest are moving very fast and are invisible to our eyes, therefore complex methods of detection are required to detect them. The purpose of the Cosmic Cube is to detect these particles during a shower caused by a cosmic event. The Cosmic Cube will convert the invisible particles into electrical signals that can be processed, measured, recorded, and compared. The product also will be designed such that it can easily integrate with others so that more of a particular event can be detected.

## **1.2. The Team**

This team consists of five engineering students. Two of the students are ME majors and have a background in mechanics and structures. The other three students are ECE majors and have a background in electrical systems and programming. Skills possessed by the team include the following: programming, CAD design, troubleshooting, machine work, and power. The team works well together and is determined to be successful. Advising the team are Ph.D.s.' with backgrounds in advanced physics and electrical engineering.

## **1.3. Target Market**

Conventional astronomy is a very popular activity for amateurs and professionals alike. Looking at the moon, stars, and tracking comets is fun for many. Currently, the only instruments capable of detecting cosmic events are only accessible to professionals, thus leaving out the amateur astronomer. The Cosmic Cube will put cosmic ray astronomy within reach of amateurs as well as link amateurs and professionals together. The goal of the Cosmic Cube is to be so accessible that it can be found on the shelves next to conventional telescopes.

The Cosmic Cube will be designed with a wide array of users in mind. In its simplistic form, the Cosmic Cube will detect cosmic events, describe the particles, and engage the user in the operation. For the amateur user, operation will be optimized for table top use and home computer interfacing. Visual indicators will alert the user to events with colors to distinguish the particle.

For the more serious enthusiasts, professionals, and academics, the Cosmic Cube will integrate into a much larger cube that is capable of detecting more events as well as direction of trajectory. The Cosmic Cube will integrate into a 27 channel cube. The basic principle, to detect particles, will be preserved except now origin of the particles can be determined.

Currently, the majority of operational cosmic ray detectors are large scale, big budget projects that require specialists in the field. This product will greatly expand the user base by focusing on ease of use, cost, and appearance. Users won't need a background in physics or engineering, only an interest in science.

#### **1.4. Funding**

Currently, the Cosmic Cube has been given \$750.00 from FSU College of Engineering's ECE department. Additionally, Dr. O'Neal will be providing samples of scintillator, lead-free substitute, and photo-detectors. Dr. Frank has also indicated that there may be additional funding if absolutely necessary. The team is currently seeking donations for the other components to put towards the Cosmic Cube prototype.

#### **1.5. Summary**

To date, nothing exists on the commercial market that can appeal to both the amateur and the professional in cosmic ray astronomy. By simplifying the operation and minimizing the cost while maintaining the usefulness of the collected data, the Cosmic Cube will become not only a popular product but also a useful tool for science. Our team will ensure this level of success by devoting our time to ensuring proper operation while engaging the user in the operation.

## **2. Introduction**

### **2.1. Acknowledgement**

The Cosmic Cube team would like to acknowledge Dr. Ray O’Neal and Dr. Michael Frank. Both professors have been an integral part of the designing process and framework of the overall development of the cosmic cube. Dr. O’Neal, with a background in physics and particle astronomy, helped shape the design and functionality of the cube. Dr. Frank, with a background in computer and electrical engineering, provided insight on how to approach the network of circuitry needed for the project.

### **2.2. Statement of Problem**

There is a need to detect high-energy cosmic rays because although research has been done regarding the subject, the exact origins of these extremely high-energy particles are not exact. Detecting these cosmic ray showers on earth and recording the presence, timing, energy levels, and trajectory can help to link the rays to possible events in space that could have produced these showers on earth. There are cosmic ray detectors already in operation yet this model is meant to be compact and visually stimulating to appease buyers yet still operational to maintain detector functionality.

### **2.3. Operating Environment**

The device can be operated both safely and efficiently in an inside or outside environment.

### **2.4. User Environment**

The Cosmic cube is meant to be an open source project where individuals using the device can develop their own means of translating the data provided by the cube such as event time, particle specie, and event trajectory into something more meaningful to them. The user interface will be very simple and rudimentary. Most likely it will consist of a window depicting the raw data and a means to save the data to the local hard drive or external device. Peer-to-peer style sharing, as opposed to central server based, will be utilized to share recorded event data. In addition there will be multicolored Light Emission Diodes (LEDs) found on the outside cube to indicate which type of particle just passed through the cosmic cube.

## 2.5. Intended Use(s) and User(s)

**Researchers:** Those who want to use the cosmic cube to gather data for studies and projects relating to high-energy cosmic rays. These can be individuals in universities, local high schools, and scientists out in the field.

**Backyard Astronomers/General Public:** Individuals who don't have funding or work for a major company. These are people who have interest in space maybe as a hobby or career pursuit and want to use the cosmic cube to detect high-energy cosmic ray events in their area.

**Special Application Groups:** With the added feature of being able to detect gamma rays the portable cosmic cube segment can be used in aiding with the search for nuclear devices and differentiating between materials and locations that have been contaminated by harmful radioactive material.

## 2.6. Assumptions and Limitations

### 2.6.1. Assumption

The particles that strike the scintillator will be in the range of 1-4GeV range.

### 2.6.2. Limitation

No greater than 30 cm on a given side of the Cosmic Cube.

The time resolution of the device will be no slower than 100 nanoseconds.

A commercial available Cosmic Cube when mass produce would cost approximately \$1000.

### 3. Proposed Design

Contained within this section of the document will be the overview of the Cosmic Cube as well as details that specify the characteristics of each part needed before selection. Across each aspect of the components selection process at least 3 parts were compared in order re-verify that are selection for components were correct. The parts that was selected for this project can be found in the excel graph at the end of each section. With the team selection both **bolded** and indicated with the following symbol (**\*Item #**). The majority of the team's decisions for selection of components were based cost as it was very important aspect of this project, because this product is meant to be affordable for the average consumer.

#### 3.1. Overview

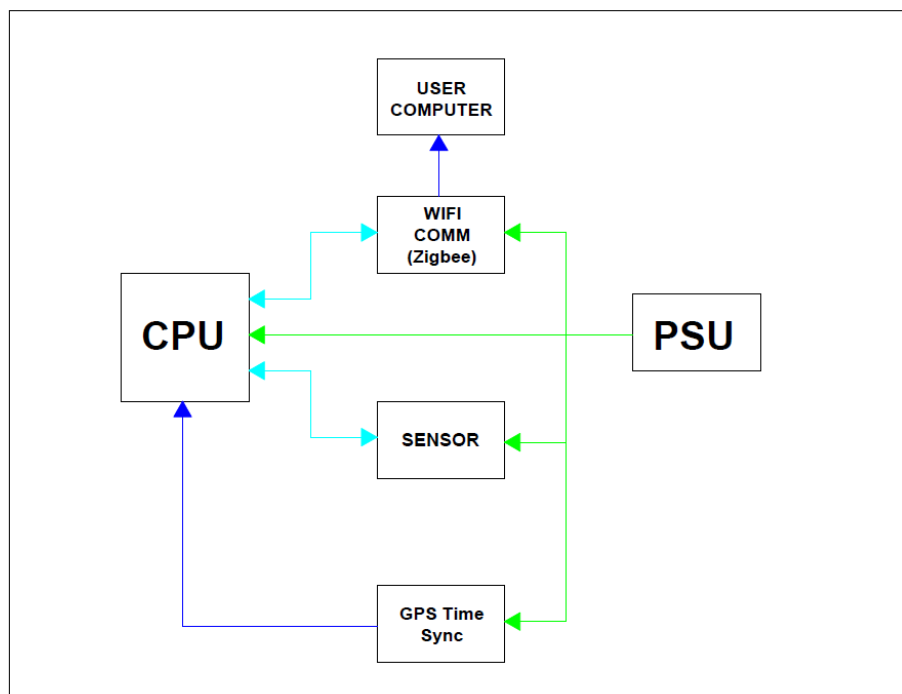



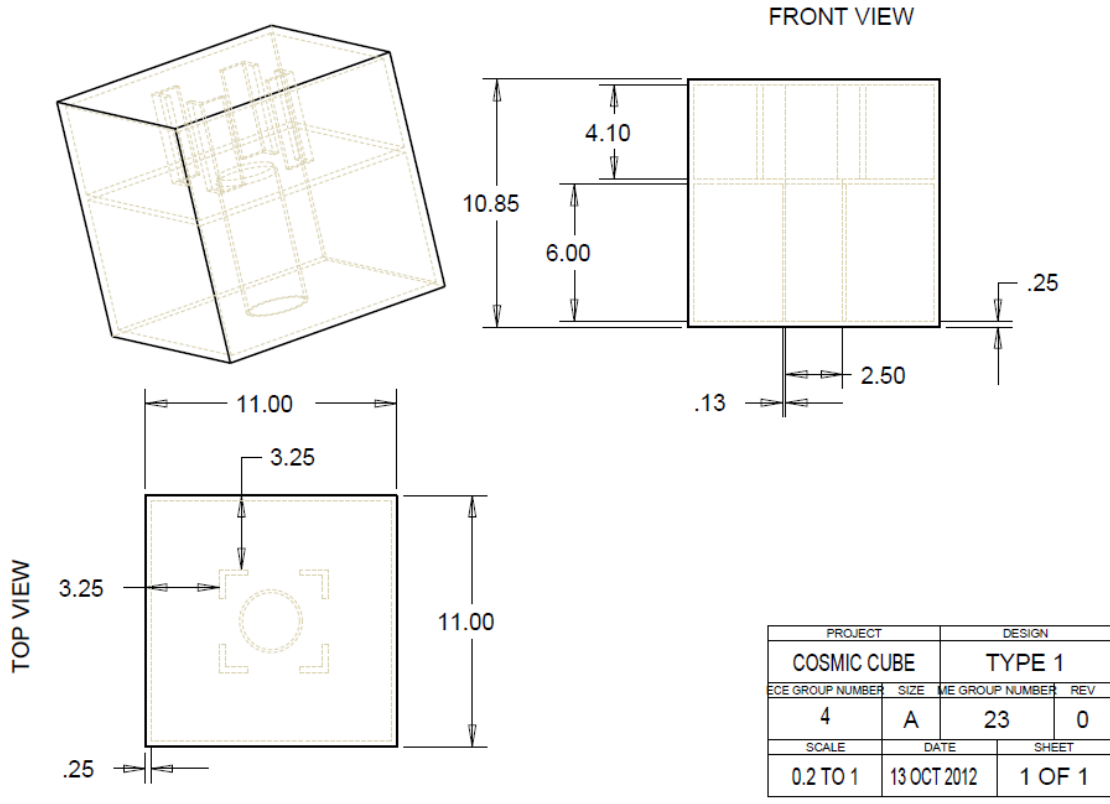
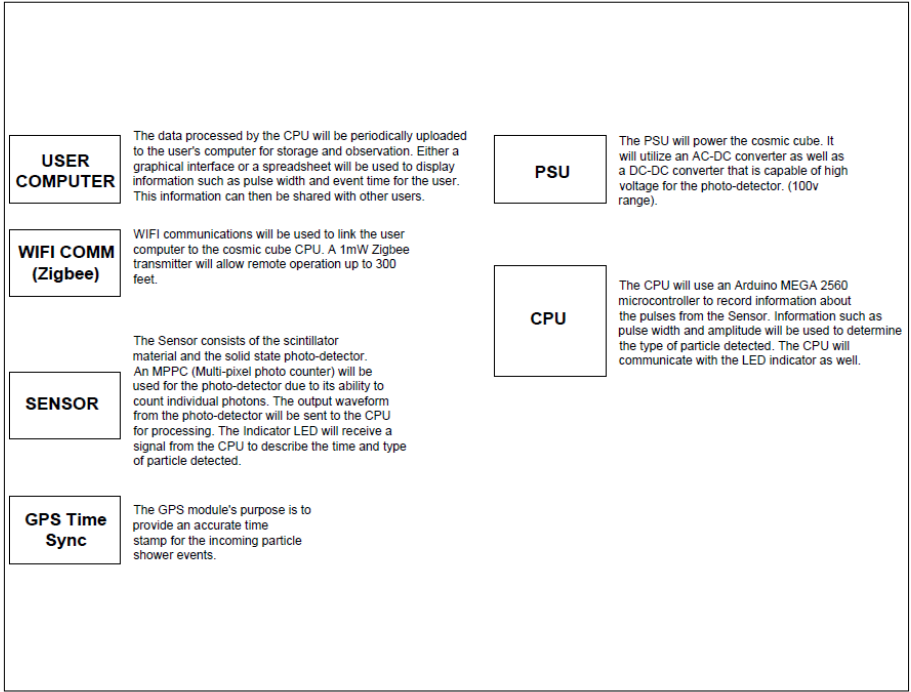

PROJECT		DESIGN	
COSMIC CUBE		TYPE 1	
ECE GROUP NUMBER	SIZE	ME GROUP NUMBER	REV
4	A	23	0
SCALE		DATE	
0.2 TO 1		13 OCT 2012	
		SHEET	
		1 OF 1	

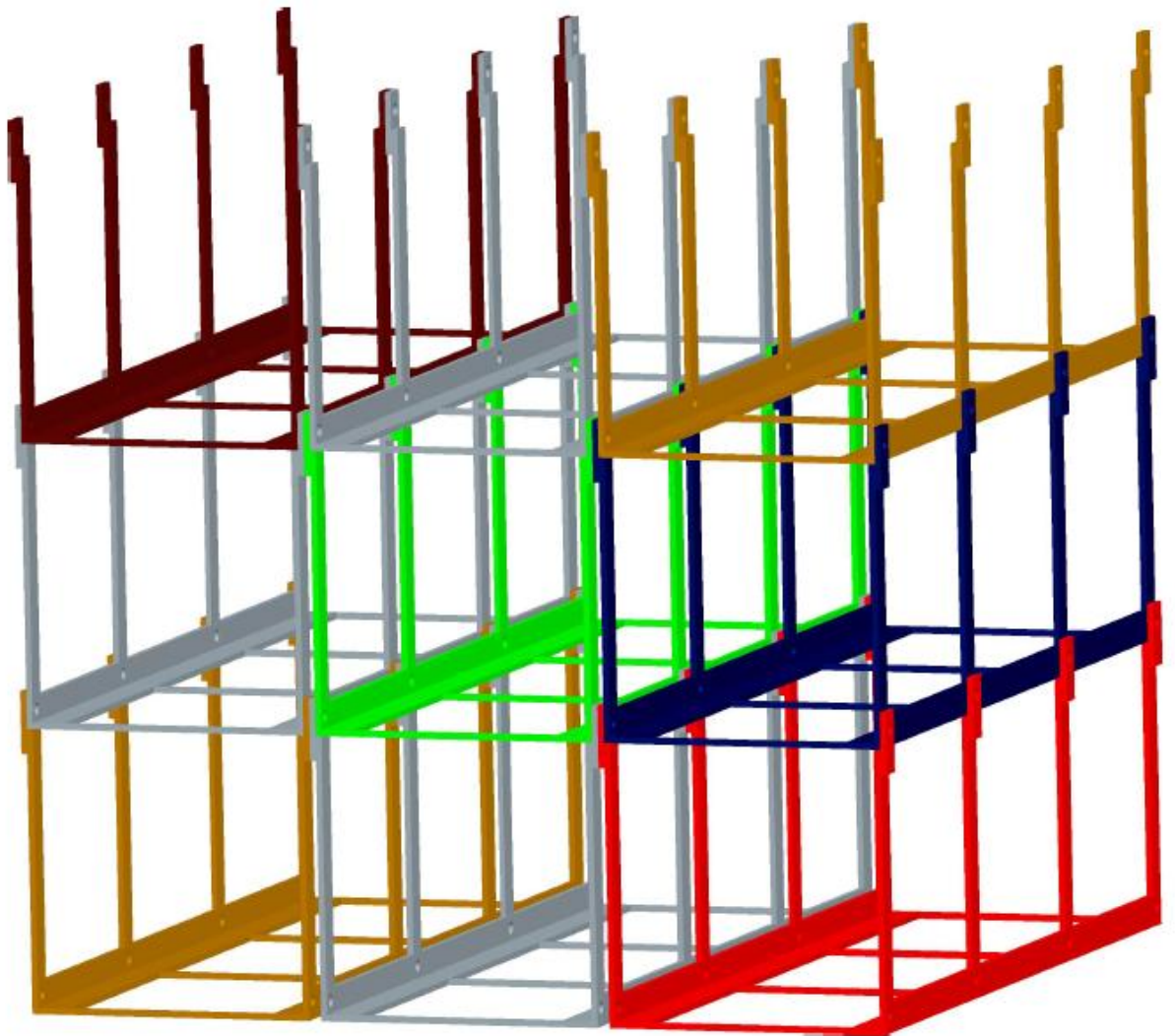

SCALE 0.175

### 3.1.1. Scintillator

The purpose of the scintillator is to convert high energy particles into photons. When the cosmic radiation strikes the dense material on the top of the scintillator material, a mini shower is created. The mini shower travels through the scintillator, depositing energy along the way. The energy from the particle shower causes the scintillator atoms to bump up to a higher energy level. When the scintillator atoms fall back to their previous state, a photon is released. The amount of photons per amount of energy deposited for the scintillator material can be calibrated using a radioactive isotope of known energy.

TYPE	PHOTONS/MeV	WL(nm)	Light Output (%)
EJ204	10400	408	68
<b>*EJ208</b>	<b>9200</b>	<b>435</b>	<b>60</b>
EJ200	10000	425	64

### 3.1.2. Photo-Detector

The purpose of the photo-detector is to turn the photons from the scintillator into an electrical signal that can be measured and processed by the CPU. The type of photo-detector to be selected will be an MPPC (Multi-pixel photon counter). This is a solid state type of detector that is capable of counting actual photons. A standalone photo-detector has an analog output. To be useful for detecting the number of photons, a digital output would have to be created from the analog signal. An MPPC module would be much more suited to this project due to its digital output.

PART #	AREA (mm <sup>2</sup> )	PEAK WL(nm)	PIXELS	COST(\$)
S10362-33-025c	9	440	14400	323.00
S10362-11-100U	1	440	100	144.00
<b>*S10362-11-025U</b>	<b>1</b>	<b>440</b>	<b>1600</b>	<b>144.00</b>

### 3.1.3. Microcontroller/CPU

The microcontroller/CPU will serve as the main hub of the cosmic cube. It will interface directly with the photo-detector, Global Position System (GPS), WI-FI, Personal Computer and possibly a multi-color LED. The microcontroller will receive a pulse or change in voltage values from the photo-detector to signify the detection of photons generated from the cosmic particle striking the scintillation material. The GPS will be used by the microcontroller to help keep both accurate and precise timing data for when the cosmic rays

are detected in a frequency of nanoseconds. Wi-Fi will be used to output the data to the user of the Cosmic Cube's personal computer in a format that is availability to the user for any analysis. In addition the microcontroller will send a signal to a multi-color LED to indicate the type of cosmic particle detected.

Part	Clock Speed (ns)	# of Channels	Memory	Interrupts	Price (\$)
Stratix III	2	272 I/O	144KB	Y	2,895.00
<b>*Arduino Mega 2560 R3</b>	<b>63</b>	<b>54-D-I/O; 16 A-I</b>	<b>256KB</b>	<b>Y-External</b>	<b>58.95</b>
DAQ-2000	25	24-D-I/O;4 A-I;	-	Y	595.00

### 3.1.4. Global Position Systems (GPS)

The GPS module chosen for the design project will be the Resolution T GPS Timing Receiver. The purpose of the GPS is to provide accurate timing data for events recorded by the Cosmic Cube. With an out of the box accuracy of 15ns the Resolution T beats out other GPS timing receivers. Another GPS considered, the LEA-6T, is capable of reaching an accuracy of 15ns but requires additional programming to remove the quantization error. The Resolution T also allows for easy integration into the design of the cube. The GPS comes with accompanying interfacing board with power supply and USB port.

GPS Receiver	Timing Accuracy	Output Frequency	Power Consumption
<b>*Trimble</b>	<b>15 ns</b>	<b>10MHz</b>	<b>350mW</b>
58540A GPS	110 ns	10MHz	15 W
LEA-6T	15-30 ns	10MHz	120mW

### 3.1.5. Wi-Fi

As data is accumulated, the cosmic cube will need to upload to the user's computer. Since we would like this to be able to operate outside of the building (for high speed electron detection), WIFI communications were chosen as the means to link the user computer to the data. This will allow the user to be some distance away from the cosmic cube while it operates as well as potentially allow more than one user to see what the cosmic cube sees.

PART #	Range (ft)	Data Rate (kbps)	COST (\$)
XB24-Z7WIT-004	400	250	25.95
DEV-11287	?	?	84.95
<b>*WRL-08665 (SparkFun)</b>	<b>300</b>	<b>250</b>	<b>22.95</b>

### 3.1.6. Structure

The majority if not all of the electronics will be enclosed inside of the cube itself. The cube size is currently an estimation made on a 2.5” diameter circular sensor that is 6” tall, and the scintillator material being 4” on a side. The cube has two compartments, one which holds all of the electronics including the sensor, and other that holds the scintillator. The sensor will slide into a cylinder in the bottom compartment to help block out light, and the lens will be just high enough so that there will not be any unnecessary pressure from the weight of the scintillator on the lens. To connect the cubes together, the system will have a cubby holes type design, where each cube has a slot it can slide into, and the systems can be expanded upon to add more cubes just by buying more sections and bolting them on.

<b>Possible Ray Scatter Materials</b>		
<b>Material</b>	<b>Density (g/cm<sup>3</sup>)</b>	<b>Price (\$/ounce)</b>
Lead	11.36	\$0.06
Silver	10.49	\$34.60
Bismuth	9.78	\$1.06
<b>Possible Cube Materials (12x12 Plate, 0.25" Thick)</b>		
<b>Material</b>	<b>Weight/Ft<sup>2</sup> (lbs)</b>	<b>Price (\$)</b>
Plastic Acetal	1.8126	\$27.58
Al 6061	3.528	\$28.54
Stainless Steel	10.322	\$96.11

### 3.1.7. Light Emitting Diode (LED)

The cosmic cube will have a visual indicator that will light whenever a cosmic event is detected. A multicolor LED will be used that will flash a different color depending on the type of particle detected. For instance, a muon could be indicated with a “red” flash from the LED. The LED indicator would be placed such that maximum visibility is achieved. Since this project has a commercial product in mind, an LED was decided as a cheap, yet entertaining method of engaging the audience.

### 3.1.8. Radioactive Isotope

The sensor (scintillator plus photo-detector) will require calibration. Radioactive isotopes can be used since they emit similar radiation. A gamma source with known electron voltage, such as Co-60, can be acquired for a reasonable cost and without the need for a special license. Since the scintillator material is given with known photons per electron voltage specification and Co-60 sources are reasonably calibrated, the resulting photons produced from a cosmic event can be compared to our

calibration for use in determining what was detected. The calibration isotope will be left in place so that the cosmic cube can be periodically checked for proper operation.

ISOTOPE	ENERGY (KeV)	Half-Life (years)
<b>*Co-60</b>	<b>1173.2, 1332.5</b>	<b>5.27</b>
Cs-137	661	30.1
Eu-152	1408	13.5

## **4. Statement of Work (SOW)**

### **4.1. Task 1: Project Management**

As the project manager, Kenneth will be responsible for making sure that the team is staying on track with the project schedule found in section 7. He will make sure to hold weekly team meetings so that any engineer on the team can discuss any issues or risk that could slow or stop development progression. During each weekly meeting he will identify and document the current progress of each engineer, update the correlating Schedule/Work Plan and make sure all the milestones are met.

### **4.2. Task 2: Preliminary Design and Development**

#### **4.2.1. Subtask 1: Identify & Prepare Sensor**

##### **4.2.1.1. Objectives**

The Sensor consists of both the scintillator and solid state photo-detector. Before the sensor can be assembled, the scintillator has to be prepared. The scintillator will need to be polished and shielded from visible light. The photo-detector will have to be attached to the scintillator such that contamination is minimized.

##### **4.2.1.2. Approach**

Polishing the scintillator will require using different grades of sandpaper and polishing compounds. Coarse sandpaper will be used first and the grade gradually increased to very fine sandpaper. The final polishing will use a buffing compound. All of the sanding should be done on a very flat surface, such as a lapping surface, to ensure even sanding.

Since the scintillator is sensitive to light as well as cosmic particles, light shielding must be use. Tyvek is a synthetic fiber material that is used in many common applications such as housing and mailing envelopes. Tyvek will be recycled from Priority Mail envelopes and used to wrap the scintillator.

The final part of the sensor is the photo-detector. The photo-detector will need to be attached to the scintillator in a clean environment to minimize contaminates. Optical compound will be used to form a low refractive index interface between the photo-detector and the scintillator. Ideally, a clean room intended for optics would be used for attaching the photo-detector to the scintillator. In the event that a clean room cannot be used, then a moist room with little ventilation will have to be used.

#### **4.2.1.3. Test/Verification Plan**

To test the sensor once assembled, the sensor will be connected to an oscilloscope and the output observed. If everything has been assembled correctly, then very little output should be observed on the oscilloscope. Bad light shielding should show a lot of false activity. Radioactive isotope sources will be placed near the sensor and an output should be observed on the oscilloscope.

### **4.2.2. Subtask 2: Identify & Prepare Microcontroller**

#### **4.2.2.1. Objective**

To prepare the microcontroller to operate and coordinate all the parts of the cosmic cube will take both extensive and in-depth programming. The microcontroller will need to be able to analyze any incoming data from the sensor then both time stamps when the cosmic particle struck the scintillator material and record the amount of energy coming from that particle. After that, output the corresponding data to a laptop or WIFI enabled device for further analysis.

#### **4.2.2.2. Approach**

In order for the microcontroller to be able to complete this objective, the microcontroller will have to be programmed in parts or phases due to the multiple interfaces. The first part to be programmed and interfaced with the microcontroller will be based on a hierarchy of what is the most important part to the least important part needed. The first part will be the sensor making sure that the microcontroller can detect the change in voltage value coming from sensor as well as the magnitude. The next part to be programmed will be the Global Position System (GPS) Chip. The GPS will be programmed because it is significantly important that the data be time stamped to the nearest 100ns because the rate at which cosmic rays strike the scintillator is 100ns. Finally, the WIFI will be programmed and interfaced with the microcontroller. This is because the means by which the data is sent to the user personal computer is not extremely important it is more important that the data is recorded accurately and precisely.



#### **4.2.2.3. Test/Verification Plan**

For verification that each part is working properly embedded in each set of code for each interfaced part will be test code or similarly “Print statement” that will verified where the microcontroller is operating inside the code as well as additional “Test Code” to verify when data is taken, recorded and sent to the user.

### **4.2.3. Subtask 4: Identify & Prepare WIFI**

#### **4.2.3.1. Objective**

The WIFI portion of the Cosmic Cube is to provide a link between the user’s computer and the CPU. As pulses are detected by the sensor, the CPU will process the pulses and output the pulse width, amplitude, and time. This data will be sent to the user via the WIFI link. The WIFI link will require information about the user’s computer be included in the coding that pairs the WIFI, CPU, and user computer.

#### **4.2.3.2. Approach**

When choosing a suitable WIFI module, the following will be considered: Cost, power, and ease of programming. Since the Cosmic Cube will be kept reasonably close to the user computer, a low power and inexpensive WIFI module will suffice. 1mW Zigbee modules are easy to program, relatively cheap, and can work up to 300 ft.

#### **4.2.3.3. Test/Verification Plan**

Once the WIFI link has been setup, it will be tested by attempting to send fictitious data to the user computer. If the user receives the data transmitted, the WIFI link will be determined to be successful.

### **4.2.4. Subtask 4: Identify & Prepare GPS**

#### **4.2.4.1. Objective**

The purpose of the GPS module is to provide a timing sync reference to the microcontroller. The GPS will be used as an absolute reference to real time as appose to a relative clock cycle value.

#### **4.2.4.2. Approach**

The GPS module must fit several criteria to be chosen for the design project. First it must produce a highly accurate timing reference. Cosmic ray showers hitting the cube can occur in quick successions within a time frame of one second. The GPS needs to have an accuracy of 100ns to be able to record timing for each incoming event. Second the GPS needs to be easy to incorporate with the cube design. With limited time and budget for the project having a GPS module that does not require designing an interface board will be beneficial. Therefore the GPS needs to have its own interface board equipped with USB port. This connection will be used for timing data transfer from the GPS. Lastly the Cosmic Cube will be designed with portability in mind. In keeping with this feature the GPS with interfacing module must be fully functional while taking up a limited amount of space.

#### **4.2.4.3. Test/Verification Plan**

To test the accuracy of the GPS the GPS module will be connected to a computer via USB cable. Then using software provided with the GPS module it can be determined how many satellites the GPS is currently communicating with and how within how many nanoseconds of accuracy the GPS time is with real time.

### **4.2.5. Subtask 5: Choose Isotope**

#### **4.2.5.1. Objective**

The purpose of the radioactive isotope is to test the sensor, calibrate the sensor, and provide a constant signal so that proper operation can be checked at will. Choosing the isotope will require examining commonly available sources and comparing the type of energy output. Since the purpose of the Cosmic Cube is to detect particles with energy in the 4GeV range, the isotope chosen should have the highest energy possible.

#### **4.2.5.2. Approach**

A radioactive isotope should be chosen based on cost, half-life, and energy level. Since cost is an issue, it must be considered first. Co-60 is relatively cheap (\$79.00), has a high energy gamma (1332KeV), and a reasonably long half-life (5.3 years).

#### **4.2.5.3. Test/Verification Plan**

The source will be assumed to be of correct type and energy since testing of this type material is well out of the scope of this project.

### **4.2.6. Subtask 6: Design & Construct Structure**

#### **4.2.6.1. Objective**

The portion of the cube that contains the scintillator must have no light entering that area, while still having removable panels. The Electronics being used need to be all enclosed within the cube itself. The cubes must be able to be attached to other cubes or placed in an expandable structure.

#### **4.2.6.2. Approach**

There will be two compartments inside of the cube. The bottom compartment will house the electronics, and the body of the sensor. The top compartment will contain the lens of the sensor, the scintillator, and the deflection material. L-brackets will be used to hold the scintillator and deflection material securely in position over the sensor lens. A rubber gasket can be used around the cube edges to ensure that no light enters the top compartment and gives false readings. The top compartment will be made of polished Aluminum so it will have a reflective interior and exterior. The bottom compartment of the cube will be made of clear Plexiglass. Having the electronics in a clear enclosure would have an appealing look to consumers to see the brains of the cube. In the bottom portion of the cube, there will be a cylinder in the center that the sensor will slide into in order to hold it into place, and minimize cube size.

The cubes will attach to each other through a cubby-hole type design. The cubes will individually slide onto a shelf that can hold one row of three cubes. These sections can then be bolted to the side, or on top of another section in order to add more cubes.

#### **4.2.6.3. Test/Verification Plan**

A bright light source will be shown along all of the edges of the cube to see if the sensor picks up any light detection while the cube is assembled. The cube will also be turned on all sides to make sure all of the components are securely in place.

A cube will be placed in the structure to check for clearances, and stability of the structure. As more portions of the structure are added, it should become more stable as well. A maximum weight limit may need to be determined for the structure.

## **4.2.7. Subtask 7: Power Supply Unit (PSU)**

### **4.2.7.1. Objective**

The power supply needs to be able to power the entire Cosmic Cube. This includes the Arduino CPU, GPS, WIFI, LED, and the Photo-Detector.

### **4.2.7.2. Approach**

A power supply that has multiple outputs that could power all the components would be ideal. Most of the electrical components require 5V. The Photo-diode will likely need a converter, possibly a DC-DC converter, which is capable of providing 100V. The PSU should account for the total current draw of all components yet sized correctly to avoid paying for unnecessary current capacity.

### **4.2.7.3. Test/Verification Plan**

Testing of the PSU will require using a digital multi-meter to check voltage and current.

## 5. Risk Assessment

The cosmic cube segments are designed to be operated either indoor or outdoor between temperature ranges of 27-100 degrees Fahrenheit ((-3)-38 degrees Celsius).

The segments will be resistant to water. However, do not submerge the cube segments in water or expose them to rain, as the user will risk possible electrocution and/or damage the electrical components within the cube.

Do not excessively shake or drop cube segments. The scintillator material incased within the device is very delicate and may fracture or break when struck.

## 6. Qualifications and Responsibilities of Team Members

### 6.1. Qualifications of Matthew Gibson

Matt Gibson is a Senior ECE student. He has built electrical projects all his life relating to power and energy. He is able to solder, design circuit boards using CAD, troubleshoot using oscilloscopes and digital multi-meters as well as utilize design software such as AutoCAD. Matt Gibson has held a job at a local utility for nearly 1.5 years working as an Engineering Intern. He has chosen power as a concentration and plans to go into either the utilities or power plants. Matt Gibson has taken charge of the sensor (scintillator and photo-detector), power supply, and radiation source. Matt Gibson also has earned a math minor.

#### **Responsibilities:**

*Lead Electrical-Computer Engineer (ECE)*

### 6.2. Qualifications of Cole Gray

Cole Gray is a senior in Mechanical Engineering with a minor in physics and mathematics, and is in the Dynamics Systems and Controls track. Cole has always tinkered with things, taking them apart to see how they work, and making things from scratch, which requires good problem solving skills. He recently built a 350 cubic inch motor from the bare blocks and converted into a 1984 Toyota Pickup. He is efficient at working in a team and getting his designated parts done on time, while also giving suggestions on how to better the system. Cole is innovative, and can think outside the box when needed when designing a new product. He can solve problems as they arise in a design, as well as foresee possible future problems with current designs. Cole will

spend as much time as required to get a job done right, as opposed to rushing to finish on time with an unsafe product.

**Responsibilities:**

*Lead Mechanical Engineer (ME)*

**6.3. Qualifications of Crystal Hill**

Crystal Hill is a Mechanical Engineering major. Her main duty is to manage the budget for the project. The qualifications that she has for this position include experience working as a bookkeeper for the Pfeiffer Law Group, where she has been employed for the past 1.5 years. Crystal has also successfully completed courses in Materials Science, Mechanics of Materials, and Engineering Design Methods. These courses are relevant to material selection, structural design, as well as advanced techniques in the engineering design process.

**Responsibilities:**

*Financial Advisor*

**6.4. Qualifications of Don Lundi**

Don Lundi is an Electrical Engineering student at Florida State University. Don has completed related courses dealing in computer architecture, intro into field programmable logic devices, and micro based system design. Don has always shown interest in the field of mathematics at an early age and expanding his educational pursuits into engineering allowed him to apply his love of math into practical facets of his life.

**Responsibilities:**

*Electrical-Computer Engineer (ECE) Assistant*

**6.5. Qualifications of Kenneth Spradley**

Kenneth Spradley a senior electrical engineering student at Florida A&M University (FAMU) slated to graduate in spring 2013. He will serve as the Cosmic Cube's both Team Lead and Lead Programmer. Kenneth has worked as the lead programmer in the Title III Research at FAMU for Dual Autonomous Land & Air Security and Surveillance. He also interned for Ford in the summer of 2012 where he

managed a team of engineers to conduct a Gage Repeatability & Reproducibility on Switch Feel Equipment to confirm the validity of the data received from this extremely sensitive equipment. His extensive studies at the FAMU-FSU College of Engineering include numerous classes that can be applied to the project Digital Logic, Microprocessors, Field Programmable Logic Devices (FPLD) and Digital Communication.

**Responsibilities:**

*Team Leader*

*Lead Programmer*

## 7. Schedule

*\*See page 29\**

## 8. Budget

	<b>Total Hours</b>	<b>Hourly Rate</b>	<b>Total</b>
<b>Personnel</b>	(31 Weeks)		
Matthew Gibson (EE)	372	\$30.00	\$11,160.00
Cole David Gray (ME)	372	\$30.00	\$11,160.00
Crystal Hill (ME)	372	\$30.00	\$11,160.00
Don Lundi (EE)	372	\$30.00	\$11,160.00
Kenneth Spradley (EE)	372	\$30.00	\$11,160.00
		Subtotal:	\$55,800.00
		Fringe Benefits (29%)	\$16,182.00
		<b>Total Personnel Cost:</b>	<b>\$71,982.00</b>

<b>Expenses</b>	<b>Cost</b>	<b>Quantity</b>	<b>Total</b>
Scintillator Material (EJ-208)	\$500.00	1	\$500.00
Photo Detector (S10362-11-025U)	\$144.00	1	\$144.00
Microcontroller (Arudino Mega 2560 R3)	\$58.95	1	\$58.95
Wi-Fi Shield (Arduino DEV - 11287)	\$84.95	1	\$84.95
GPS (Trimble Receiver 52664-45)	\$108.72	1	\$108.72
Radioactive Isotope (Cobalt 60)	\$79.00	1	\$79.00
LEDs	\$6.58	1	\$6.58
Plexiglass (3/16"x12"x48")	\$24.99	1	\$24.99



Aluminum Plate (3/16"X12"X48)	\$47.65	1	\$47.65
Lead Plate (1/8"X12"X12")	\$47.91	1	\$47.91
Angle Aluminum (1/8"X4')	\$9.69	1	\$9.69
<b>Total Expenses:</b>			<b>\$1,112.44</b>

<b>Overhead Costs</b>		
Total Direct Costs	Personnel+Expenses	\$73,094.44
Overhead Costs	45% of Direct	\$32,892.50
Equipment		0
<b>Total Project Cost</b>		<b>\$105,986.94</b>

## 9. Deliverables

Below is a list of deliverables that will be turned in at the completion of the Cosmic Cube design project. This list is subject to change while the project is ongoing.

- User's Manual
- 1 cube segment complete with
  - Enclosure
  - Scintillator
  - Solid-state Photodiode
  - GPS Module
  - DAC board
  - Wi-Fi Module
  - Power Supply
- Design schematics
- All codes files developed for microcontrollers

## 10. References

- ELGEN-Scintillator specifications
- Hamamatsu-Photo-Detectors
- <http://hardhack.org.au/book/export/html/2>, Cosmic Ray Detectors
- <http://www.arduino.cc/>
- Burr, K.C.; Gin-Chung Wang; , "Scintillation detection using 3 mm × 3 mm silicon photomultipliers," Nuclear Science Symposium Conference Record, 2007. NSS '07. IEEE , vol.2, no., pp.975-982, Oct. 26 2007-Nov. 3 2007 doi: 10.1109/NSSMIC.2007.4437179 URL:  
<http://ieeexplore.ieee.org.proxy.lib.fsu.edu/stamp/stamp.jsp?tp=&arnumber=4437179&isnumber=4437154>
- [http://www.onlinemetals.com/merchant.cfm?pid=724&step=4&showunits=inches&id=233&top\\_cat=1](http://www.onlinemetals.com/merchant.cfm?pid=724&step=4&showunits=inches&id=233&top_cat=1)<http://www.indexmundi.com/commodities/?commodity=lead>
- <http://www.kjmagnetics.com/proddetail.asp?prod=D61AD-P>
- [http://freckleface.com/shopsite\\_sc/store/html/polycarbonatesheetthreesixteenthsinchthick.html](http://freckleface.com/shopsite_sc/store/html/polycarbonatesheetthreesixteenthsinchthick.html)
- [http://us-dc1-order.store.yahoo.net/cgi-bin/wg-order?ysco\\_key\\_event\\_id=&ysco\\_key\\_store\\_id=yhst-5570599764068&sectionId=ysco.cart&yscoc=wuuB4p4mAUcrpzx4\\_P7PiyThp7Kk049oBx8yp8A1iV1lrdwKpd13USrMQbqUAGo6J0OboWX6SS9c5t6p5WVvaZnb\\_nF9hi.8ZOQ242b4KifJj4hwqnA8BU1nPV1MZFAS7W47uPmrzY9DIEw--&yscos=7k.oPKgmAUdJpIOzq3ulaghCA7vkbqZM26kS84sGYWwgK0BDO6aCCjx.Fnqrp7DPHusgg8QM.QHCFEo9GJGFwIBl\\_fOtoikwFvFe6e4PTQDhr5JSp4Q7f.gVuhnql.3K8IyPR7ylWmyAcQ--&yscob=a7WG0JAmAUf980peHYeQ\\_8oFCw32faNnW5Zq9uk3Z0g2l\\_rt.PQxhM8PBv4sX78RzOrc8QbNbJPNm4I7Zs1ovfmuXQ\\_yoVQkP2ZA2axYemkXhc3w6wH1ObXzItD7NcJZdQ--](http://us-dc1-order.store.yahoo.net/cgi-bin/wg-order?ysco_key_event_id=&ysco_key_store_id=yhst-5570599764068&sectionId=ysco.cart&yscoc=wuuB4p4mAUcrpzx4_P7PiyThp7Kk049oBx8yp8A1iV1lrdwKpd13USrMQbqUAGo6J0OboWX6SS9c5t6p5WVvaZnb_nF9hi.8ZOQ242b4KifJj4hwqnA8BU1nPV1MZFAS7W47uPmrzY9DIEw--&yscos=7k.oPKgmAUdJpIOzq3ulaghCA7vkbqZM26kS84sGYWwgK0BDO6aCCjx.Fnqrp7DPHusgg8QM.QHCFEo9GJGFwIBl_fOtoikwFvFe6e4PTQDhr5JSp4Q7f.gVuhnql.3K8IyPR7ylWmyAcQ--&yscob=a7WG0JAmAUf980peHYeQ_8oFCw32faNnW5Zq9uk3Z0g2l_rt.PQxhM8PBv4sX78RzOrc8QbNbJPNm4I7Zs1ovfmuXQ_yoVQkP2ZA2axYemkXhc3w6wH1ObXzItD7NcJZdQ--)
- <http://trl.trimble.com/docushare/dsweb/Get/Document-550777/>
- [http://trl.trimble.com/docushare/dsweb/Get/Document-221342/ResolutionT\\_UG\\_2B\\_54655-05-ENG.pdf](http://trl.trimble.com/docushare/dsweb/Get/Document-221342/ResolutionT_UG_2B_54655-05-ENG.pdf)

## 11. Appendices

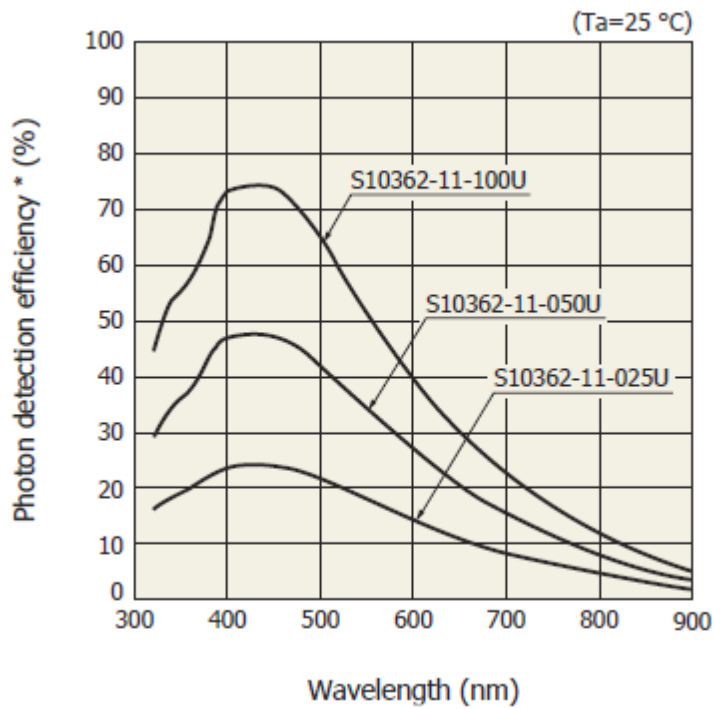
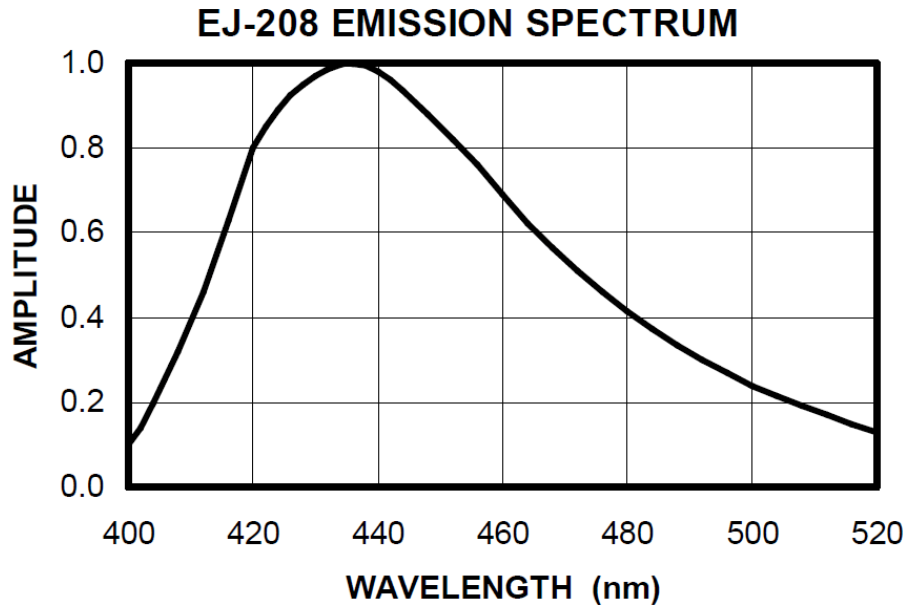

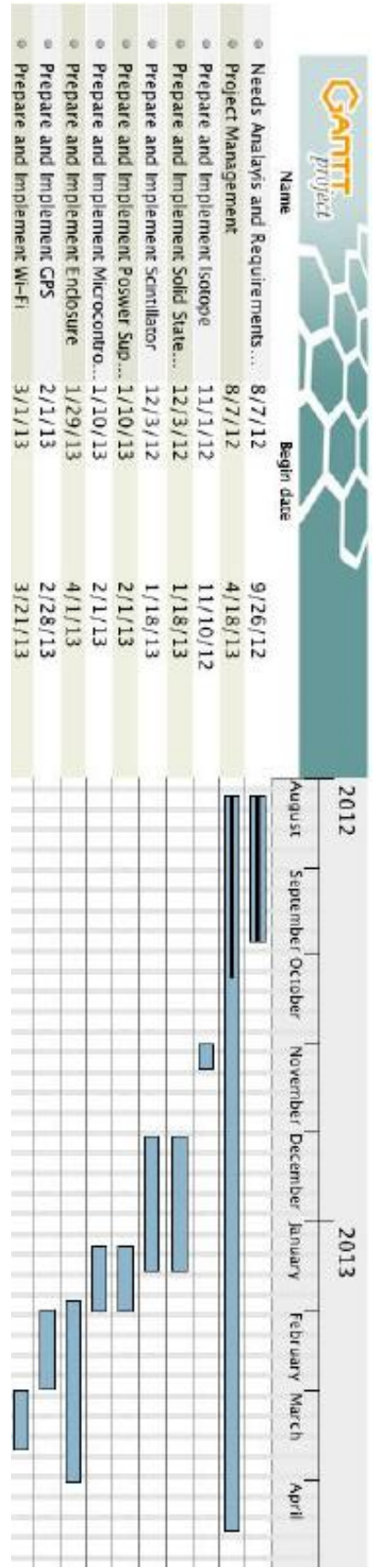



# Arduino™ MEGA 2560

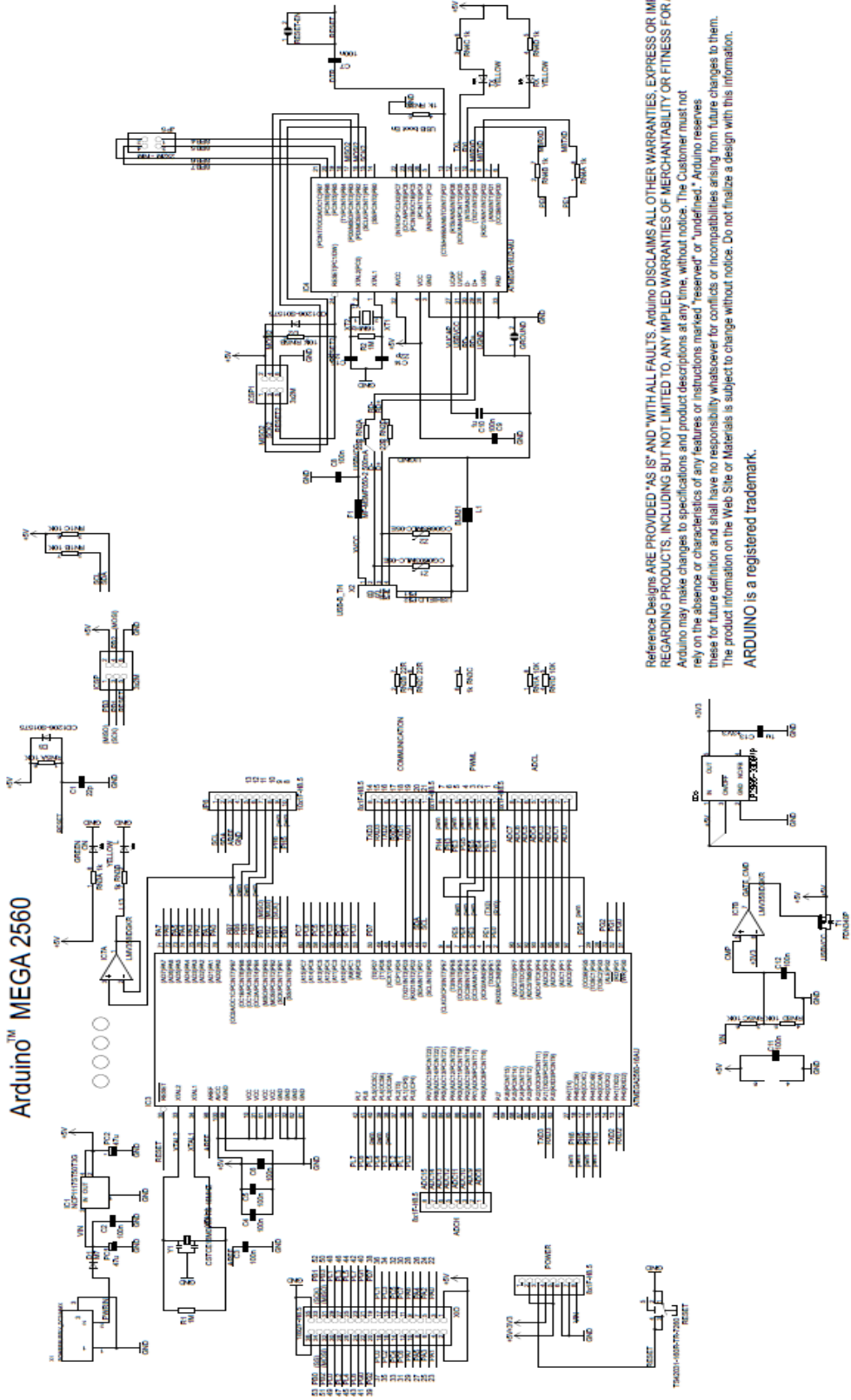

Reference Designs ARE PROVIDED "AS IS" AND "WITH ALL FAULTS. Arduino DISCLAIMS ALL OTHER WARRANTIES, EXPRESS OR IMPLIED, REGARDING PRODUCTS, INCLUDING BUT NOT LIMITED TO, ANY IMPLIED WARRANTIES OF MERCHANTABILITY OR FITNESS FOR A PARTICULAR PURPOSE. Arduino may make changes to specifications and product descriptions at any time, without notice. The Customer must not rely on the absence or characteristics of any features or instructions marked "reserved" or "undefined". Arduino reserves these for future definition and shall have no responsibility whatsoever for conflicts or incompatibilities arising from future changes to them. The product information on the Web Site or Materials is subject to change without notice. Do not finalize a design with this information. ARDUINO is a registered trademark.