



E-BIKE CHARGING & DOCKING STATION

PROJECT PROPOSAL & STATEMENT OF WORK

BRYAN CASTRO
JUSTIN JOHNSON
SEVE KIM
JACOB KNOBLAUCH
BILAL RAFIQ

INTRODUCTION

Problem Statement

- Efficient Systems, LLC is a startup company looking to expand their bike sharing system to the United States.
- Design and build a charging and docking station that users can easily access with minimal interaction.
- The stations will be used by companies for private shared use of their Efficient System E-bikes.



MECHANICAL COMPONENT SELECTION

Breakdown

- Material Selection
 - Structure and Housing
- Security System
 - Clamping Device
 - Locking Mechanisms
- Additional Features
 - Orientation of Bike
 - Guiding Track
 - Orientation of Station

Material Selection

Stainless Steel

- Alloyed with chromium to protect against corrosion
- High reflectivity and stains easily
- Heavy
- Aesthetically pleasing
- Difficult to paint
- Easy to weld, form, and drill
- Very expensive



Material Selection

Aluminum Alloy

- Naturally non-corrosive
- Strong mechanical properties
- High reflectivity and can be painted
- Its lightweight
- Deteriorates faster
- Slightly more expensive than other metals

High Performance Plastics

- Polyurethanes and epoxy resins
- Hard to form and mold for our design
- Expensive due to customization



Material Selection

Hot Rolled or Cold Rolled Steel

- Has most of the same mechanical properties of galvanized steel
- Corrosive
- Non corrosive paint can be applied but wears quickly



Material Selection

Galvanized Steel

- Zinc Coated for protection against corrosion
- Strong and Hard, durable
- Cheaper and abundant
- Easy to weld, form, and drill
- Not aesthetically pleasing but is non-reflective and can easily be painted





SECURITY SYSTEM

Placement of Latching Device

Tires

- May cause damage
- Further from the charging module
- Not as secure

Seat

- Its removable
- Low clearance

Bike Frame

- Handle Bars
- Front
- Back
- Middle

Clamping Device

Electro-magnetic Lock

- Low running cost, same power consumption as a conventional light bulb
- Easy to design and implement
- Needs constant power to operate

Extended Gripper

- Needs 2 actuators to accomplish the 2 degrees of movement
- Needs to be customized
- Can become complex and expensive

Clamping Device

Four Bar Robotic Claw Arm(2 DOF)

- Made by DAGU
- Aluminum design can easily be modified
- Only needs one motor
- Cheap and meets extension(7 cm) and spacing requirements(1 ft)
- End effectors need to be modified to fit onto the round part of the bike frame
- Claw arm needs a mechanism to lock it into place



Locking Mechanisms

Ratchet Gear Device

- Uses lever to lock into place
- Uses the grooves to lock which can wear faster
- Needs an additional actuator to remove lever

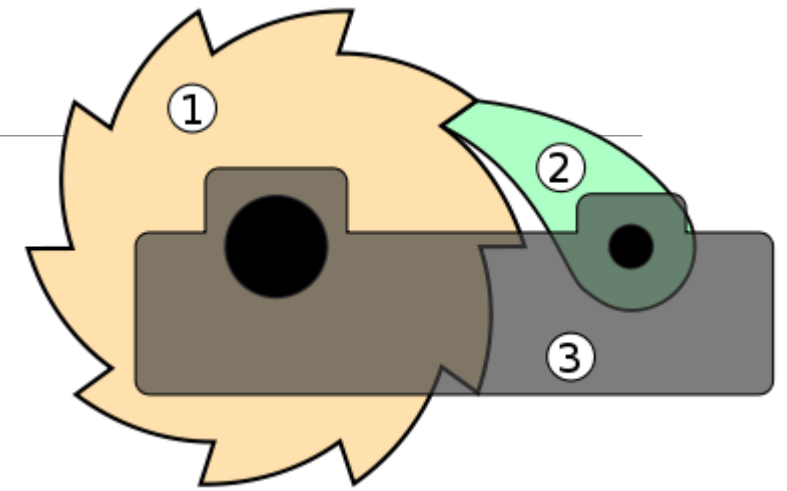

Worm Gear

- Cannot be back driven
- Strong and durable housing
- Uses a gear motor



Motors

Brushless DC motor

- Need additional gears to lower rpm

Servo motor/Stepper motors

- Need micro-controller to control
- Too complex for the design

Gear motors

- Ideal for the worm gear
- Available in all types of ratings needed
- Higher rpm, the lower the torque
- Will be chosen depending on locking time



Additional Features

Orientation of Bike

- Facing front
 - Back wheel vulnerable to theft
 - Easy access when returning
- Facing back
 - Easy access when leaving
 - Back wheel secured

Guiding Track

- Track ensures alignment against charging/locking module
- Funneled opening to assist user
- Seat aligner

Orientation of Station

- Right angled against main line
- Modular design

Prototype Design

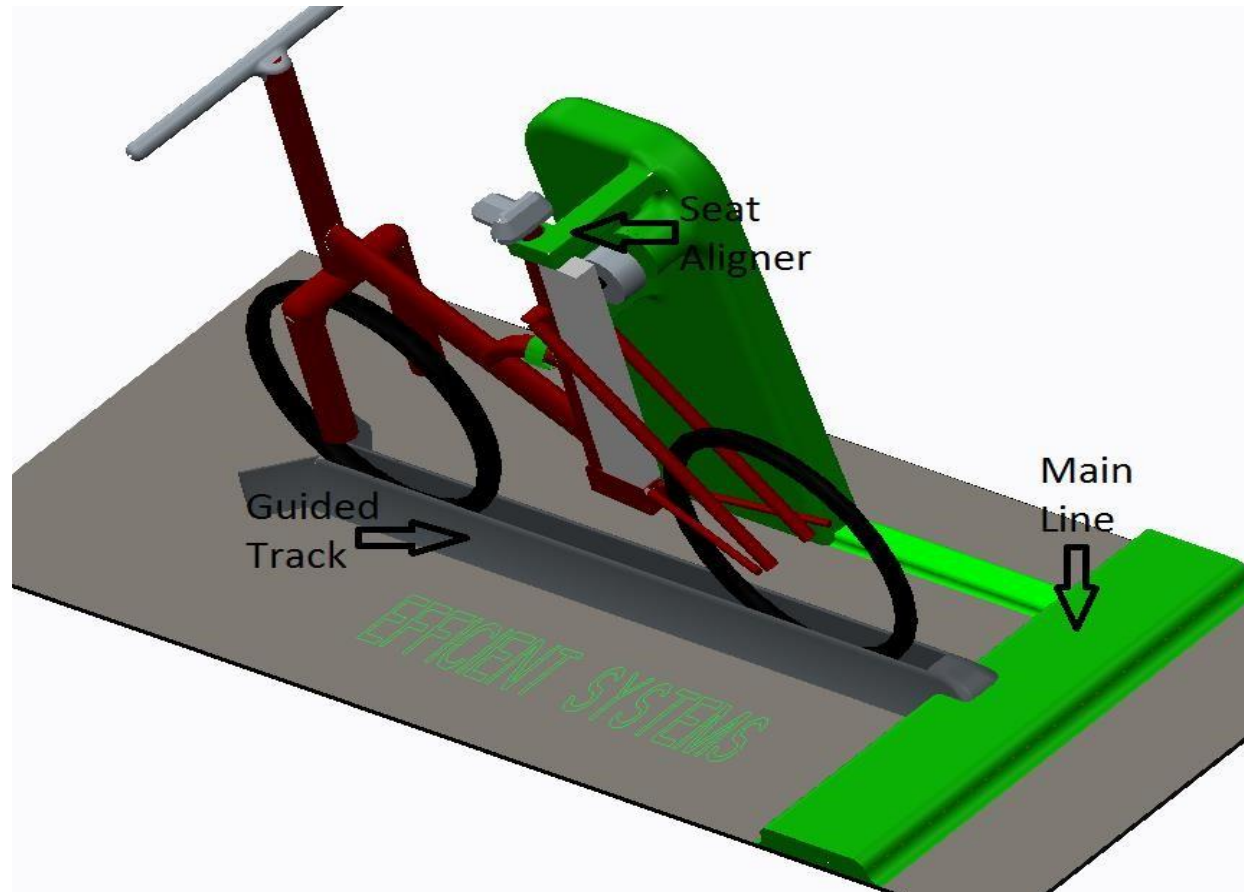

Summary of Component Selection

- Galvanized Steel
- Four Bar Robotic Claw Arm(2 DOF)
- Worm Gear
- Gear Motor
- Facing Back
- Funneled Track
- Seat Aligner
- Right Angled
- Modular Design

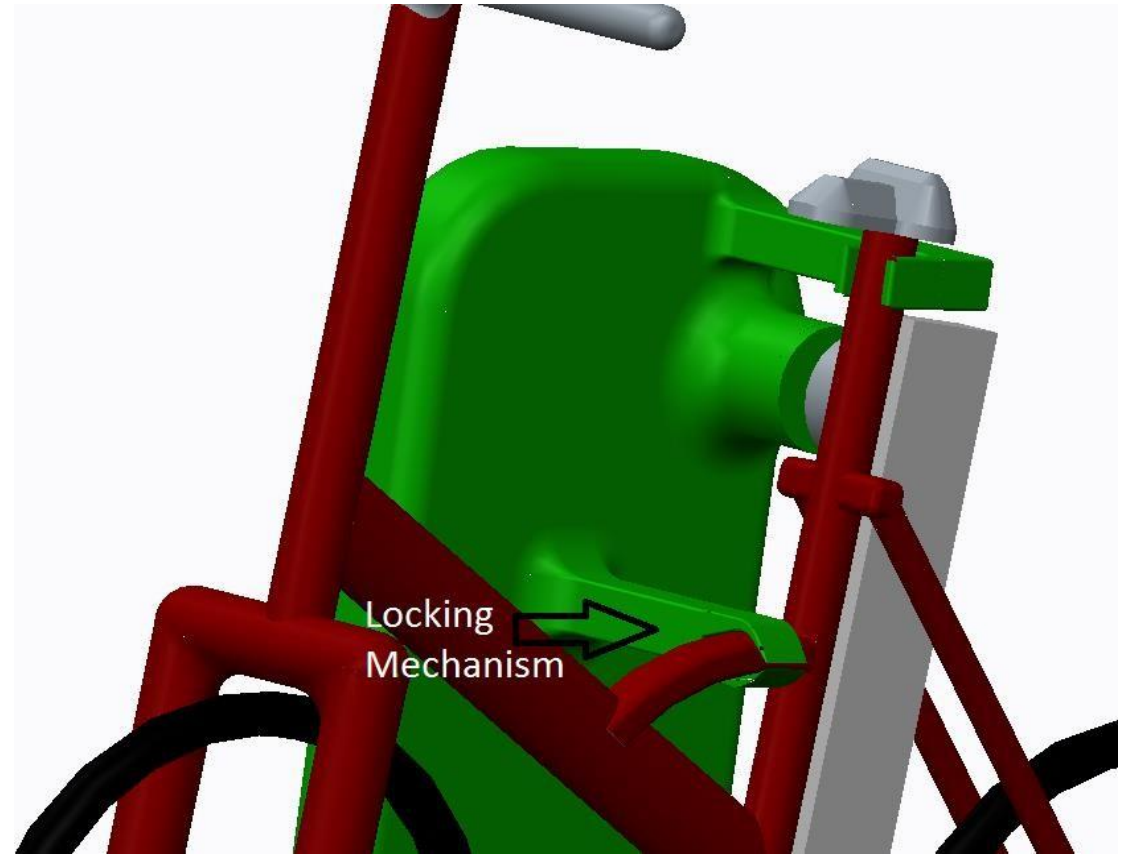

Test Plan

- Stress Test

- FEA (Finite Element Analysis) will be conducted
 - Housing Structure
 - Seat aligner
 - Four Bar Robotic Claw Arm(2 DOF)
 - Worm Gear set
- Gear Motor

- Security Test

- Four Bar Robotic Claw Arm
 - Locking Capability
 - Seat Aligner
- User Friendliness
 - Funneled Track
 - Seat Aligner
 - Modular Design
 - Mold and transform to fit various areas

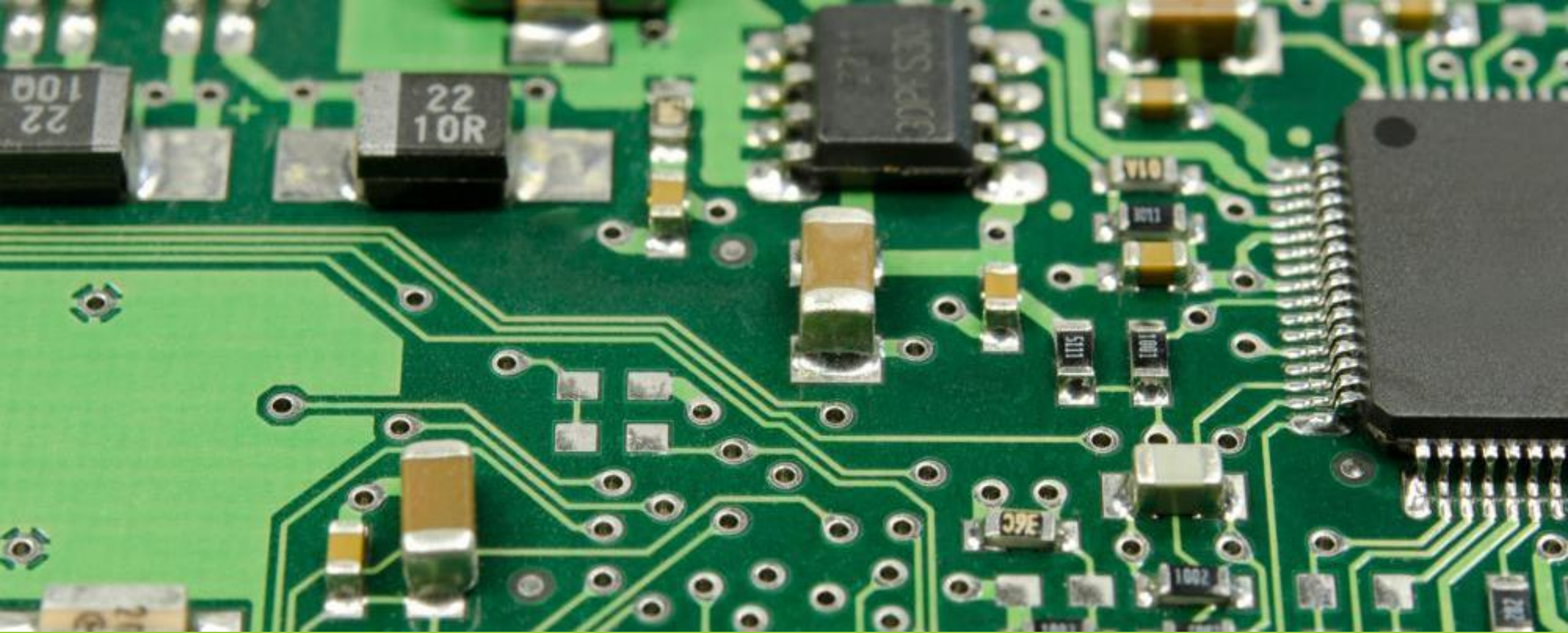

ELECTRICAL COMPONENT SELECTION

ELECTRICAL OVERVIEW

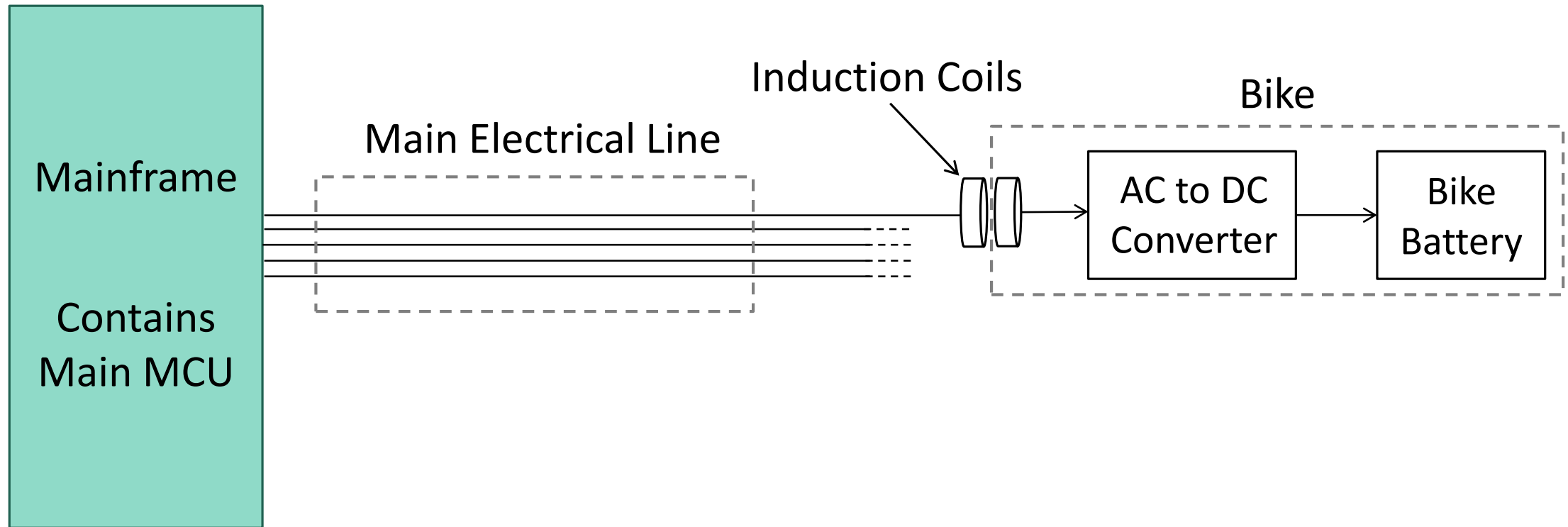

MAINFRAME

- Central hub connecting all of the bikes, supplying power and locking each station
- Single microcontroller with network capabilities
- Will interface with website for picking up bikes
- Chosen for simplicity and cost efficiency

MAINFRAME MICROCONTROLLER

The tentative Mainframe MCU to be used will be the Microchip SBC65EC:

- Built-in Ethernet connector
- 96 KB Flash, 3936 Bytes SRAM, and 64 KB EEPROM
- Default web server uses less than one-third of the available Flash and SRAM
- 32 user-programmable I/O pins, 12 user-programmable 10-bit A/D converters



MAIN ELECTRICAL LINE

- Single housing to hold all electrical lines
 - Power
 - LEDs
- 12 American Wire Gauge (AWG) housing wire will be used
- Can be set up in multiple configurations:
 - Line, bike perpendicular or angled
 - Circular

INDUCTION COIL

- Various coil sizes to be tested:
 - 70mm, 100mm 120mm
- 22 American Wire Gauge (AWG) “Magnet Wire” will be used
 - 7Amp rating
- Larger size means more efficiency, bulkier
- May need to operate in resonance for higher efficiency
- Can be used as transformer to step down voltage
- Assuming efficiency of at least 70%, a turn ratio of 2:1 to 3:1 will be needed



AC/DC CONVERTER

- Input to be converted from 110V 60Hz AC to 36V DC
- May need additional step-down before/after induction coils
- Best option for simplicity is to have converter within bike adapter
 - Seamlessly go from AC input to DC output

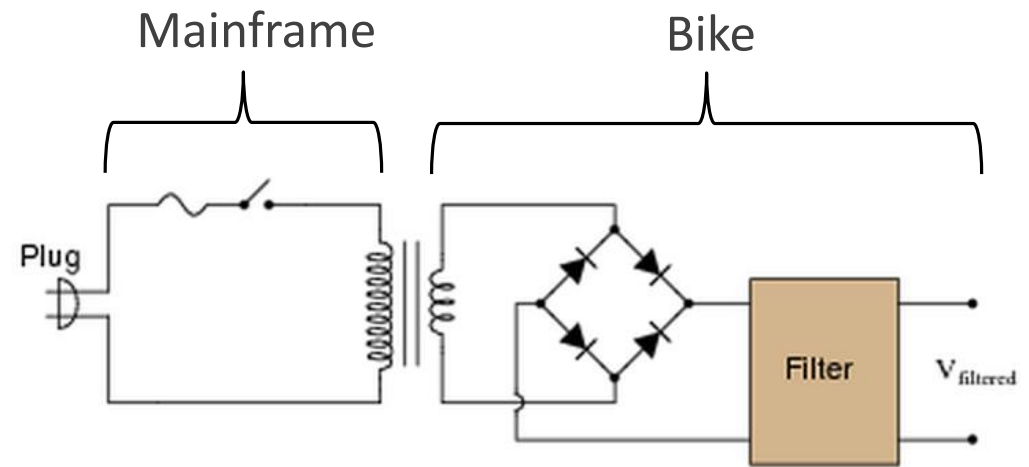

PROJECT PROPOSAL

Bike Microprocessor

- Arduino Uno R3
 - 14 I/O pins
 - 32 KB Flash, 2KB SRAM, 1KB E²PROM
 - 16 MHz clock speed
- Most likely over-specified, may eventually downgrade to cheaper MCU or FPGA
- Needs RF transmitter module for communication with mainframe

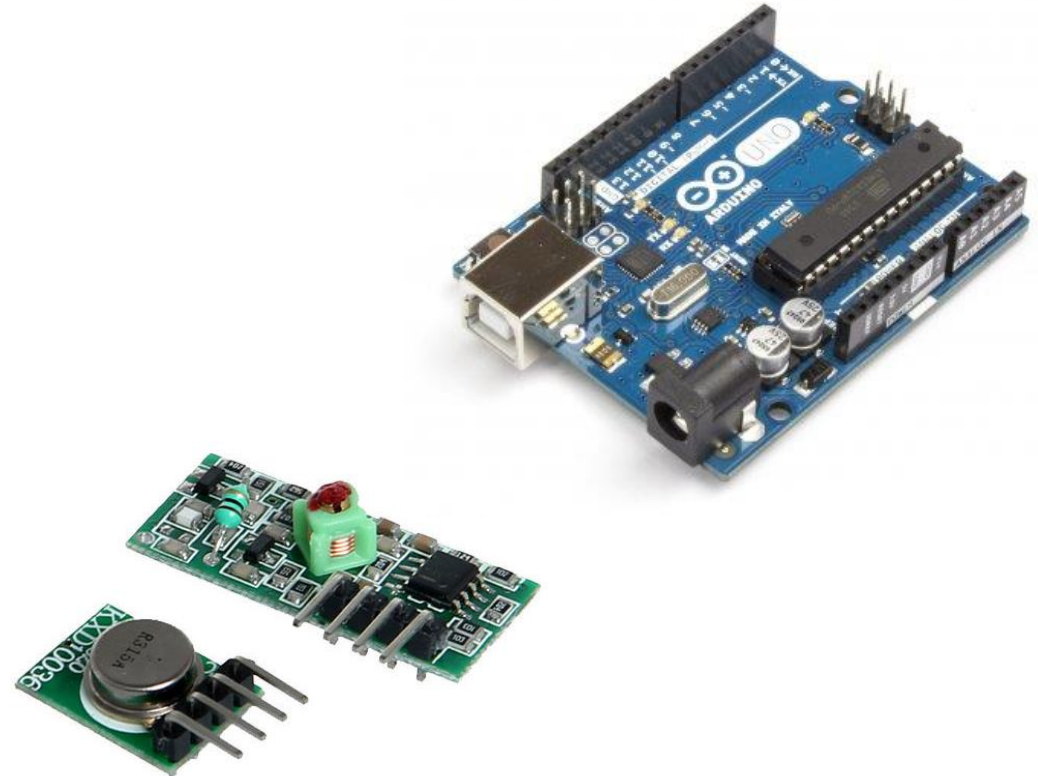

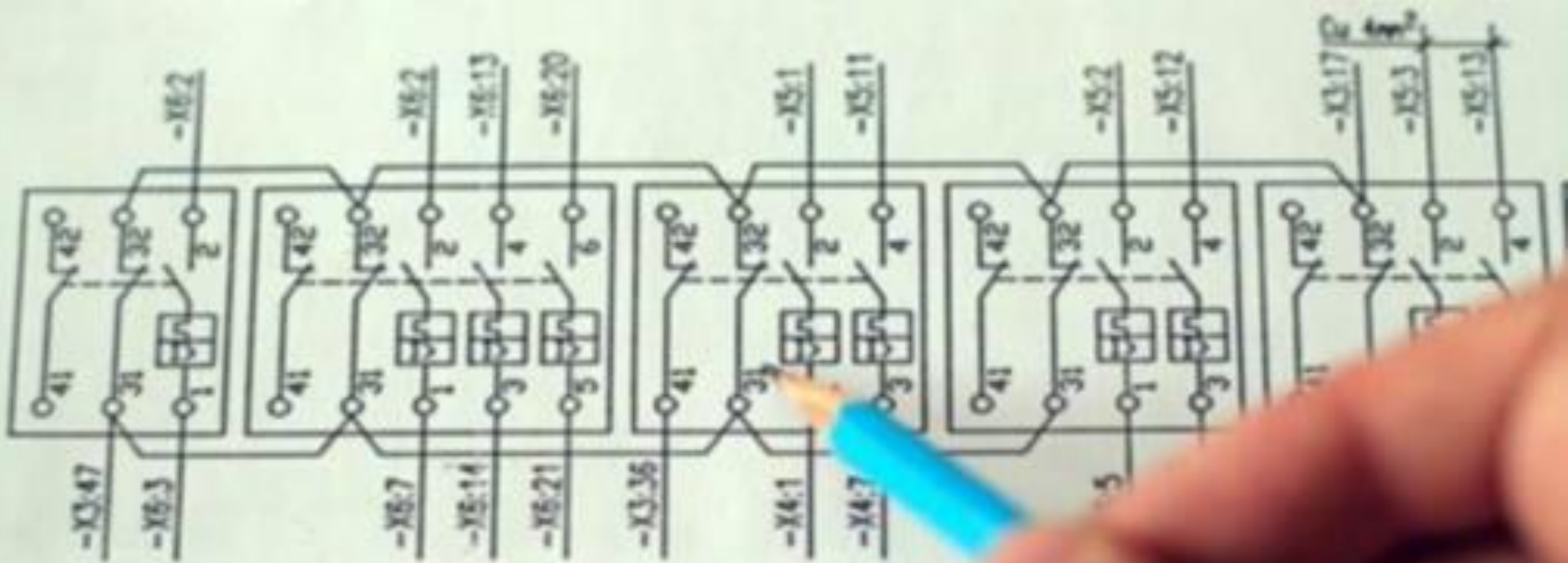

STATEMENT OF WORK

Design and Implementation

Microcontroller (Main/Bike MCU)

Objectives

- Regulate AC current for inductance
- Power efficiency
- Mind the size of components needed to fit
- Enough I/O Ports
- Steady power fed to inductance charger

Approach

- Top-level design and implementation
- Calculate specifications for induction system

Design and Implementation

Microcontroller (Main/Bike MCU)

Test/Verification Plan

- Test individual modular design
- Analyze time efficiency and response to components
- Adapts well with other selected components

Outcomes

- Fully operational with all components and creates one cohesive system
- Most efficient design possible
- Provides system checks to improve security
- Receives and gives status of battery, lock, and docked bike

E-Bike Signal

Rf Transmitter

Inductance Adapter Component

Battery Status

Charging Station Board

Power Supply

Rf Receiver

Lock

Inductance component

Microcontroller

Digital Output

Digital Input

LED Display

User Interface

Charging status

Charger

Charging Circuit

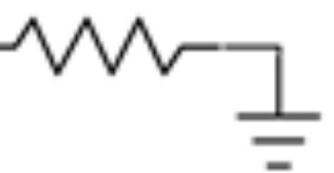

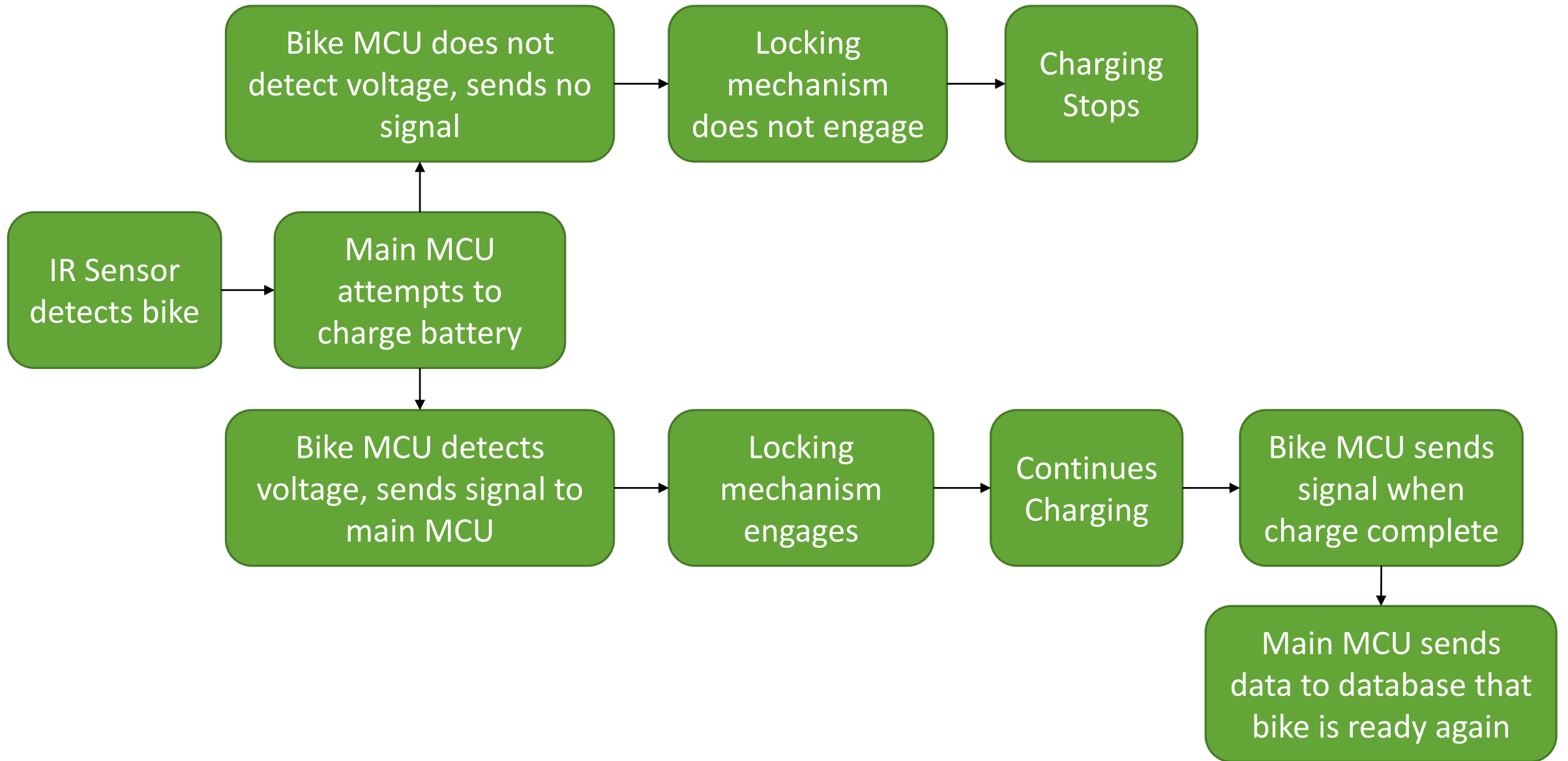

Design and Implementation

AC/DC Converter

Objectives

- Provide AC current for inductance
- Power efficiency
- Mind the size of components needed to fit

Approach

- Verify voltage has small enough variation for battery

Design and Implementation

AC/DC Converter

Test/Verification Plan

- Test input and output waveform
- Test rectifier circuit to be able to withstand given standard voltage and current (~40V & ~3A)
- Test and verify the most efficient yielded results for a converter circuit

Outcomes

- Most efficient design possible
- Inductance system has an input alternating current

Design and Implementation

Inductance Charging

Objectives

- No metal to metal contact
- Proper voltage transformation
- Fully charge as fast as possible
- Fit system in given area
- No damage shall result

Approach

- Design inductance coils and system circuit
- Calculate specifications for induction system
- Calculate efficiency
- Create a small induction system

Design and Implementation

Inductance Charging

Test/Verification Plan

- Test different inductance coil designs
- Analyze efficiency and safety
- Verify design fits in appointed area
- Test for damage caused by weather and irregular movement

Outcomes

- Fully operational inductance system
- Most efficient design possible
- Charging in less than 4 hours
- Weather-resistant components

Prototype Design

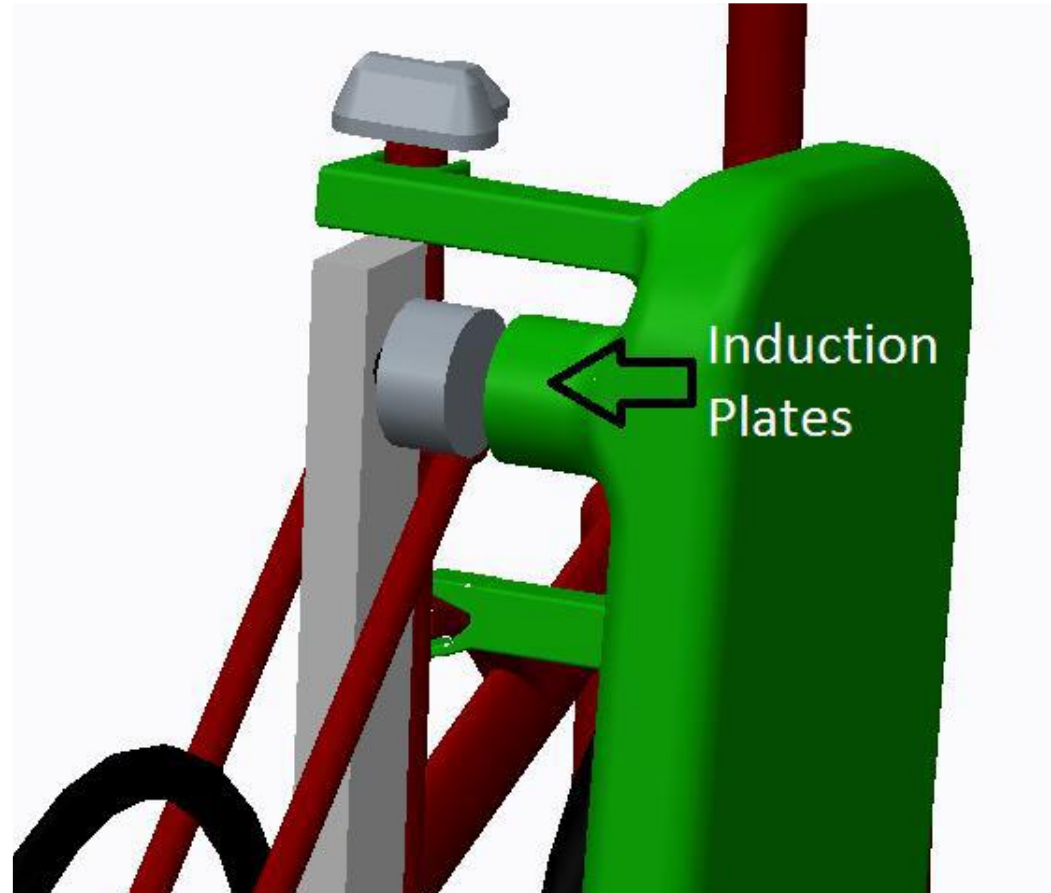



RISK ASSESSMENT

LOSS OF E-BIKE(S)

RISK

- E-bike station will be entirely automated
- Security from theft of bikes is major
- Cost of electric bikes are the majority of cost for the entire system.

SOLUTION

- Strong locking mechanism that can't be tampered with.
- Multiple authorization checks to verify bike is unlocked.
- Preventing users from creating a "false" docked status.

DAMAGE TO STATION

RISK

- E-bike station placed in a very accessible area.
- Prone to vandalism & general improper usage.
- Locking mechanism, induction charger, wiring, and housing could be dented or broken

SOLUTION

- Resilient material to provide protection against and deformation
- Welding, joints, and structure tested intensively under high stress.

POWER SYSTEM FAILURE

RISK

- Power outage
- Power supply to the station cut off
 - Locking security compromised
 - Potentially prevent charging from occurring

SOLUTION

- Locking mechanism toggles to state where it remains locked if no power signal is received.
- Microcontroller program instruction saved to static memory to ensure charging and docking properly work.

COMPONENT FAILURE

RISK

- Locking system fails
- Wires in main line housing short circuit
- Frequent maintenance might be required

SOLUTION

- Electrical components selected for design based on review and reliability
- Strong and durable component selection
- Acquiring overall reliable components not susceptible to failure.

OVERCOMPLICATED DESIGN

RISK

- Too complicated for the user
- Physical limitation to automatic locking and charging
- Fail to provide seamless user interface.

SOLUTION

- The project has made this the first priority to find a solution that is as user-friendly as possible
- This is clear before every design decision that is made
- Consider user testing from volunteers to assure easy usage and the seamless design.

Schedule



E-Bike Charging and Docking Station Project Schedule

Castro, Kim, Johnson, Knoblauch, Rafiq

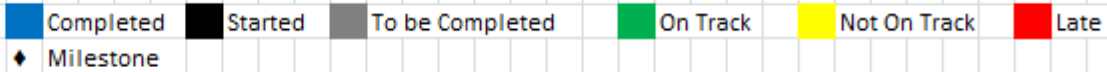

Task Name	Duration	Start	End	Sep-14					Oct-14				Nov-14				Dec-14				Jan-15				Feb-15				Mar-15				Apr-15				May-15				Jun-15			
				1	8	15	22	29	6	13	20	27	3	10	17	24	1	8	15	22	29	5	12	19	26	2	9	16	23	2	9	16	23	30	6	13	20	27	4	11	18	25	1	8
1. Code of Conduct Agreement	7 days	9/5/14	9/12/14	[Gantt bar: Started (black) from 9/5/14 to 9/12/14, On Track (green) from 9/5/14 to 9/12/14, Completed (blue) from 9/5/14 to 9/12/14 with a Milestone diamond at 9/12/14]																																								
2. Project Management	7 months	9/5/14	4/20/15	[Gantt bar: Started (black) from 9/5/14 to 4/20/15, On Track (green) from 9/5/14 to 10/1/14, To be Completed (grey) from 10/1/14 to 4/20/15]																																								
2.1 Duty Assignments				[Gantt bar: Started (black) from 9/5/14 to 9/12/14, On Track (green) from 9/12/14 to 10/1/14, Completed (blue) from 9/12/14 to 9/12/14]																																								
2.2 Sponsor Meetings				[Gantt bar: Started (black) from 9/5/14 to 9/12/14, On Track (green) from 9/12/14 to 10/1/14, To be Completed (grey) from 10/1/14 to 4/20/15]																																								
2.3 Advisor Meetings				[Gantt bar: Started (black) from 9/5/14 to 9/12/14, On Track (green) from 9/12/14 to 10/1/14, To be Completed (grey) from 10/1/14 to 4/20/15]																																								
3. Needs Analysis and Req. Specifications	15 days	9/11/14	9/26/14	[Gantt bar: Started (black) from 9/11/14 to 9/18/14, On Track (green) from 9/11/14 to 9/18/14, Completed (blue) from 9/11/14 to 9/18/14 with two Milestone diamonds at 9/11/14 and 9/18/14]																																								
3.1 Written Report	7 days	9/11/14	9/18/14	[Gantt bar: Started (black) from 9/11/14 to 9/18/14, On Track (green) from 9/11/14 to 9/18/14, Completed (blue) from 9/11/14 to 9/18/14]																																								
3.1.1 Sponsor needs/wants				[Gantt bar: Started (black) from 9/11/14 to 9/18/14, On Track (green) from 9/11/14 to 9/18/14, Completed (blue) from 9/11/14 to 9/18/14]																																								
3.1.2 Prepare Document				[Gantt bar: Started (black) from 9/11/14 to 9/18/14, On Track (green) from 9/11/14 to 9/18/14, Completed (blue) from 9/11/14 to 9/18/14]																																								
3.2 Group Presentation	5 days	9/21/14	9/26/14	[Gantt bar: Started (black) from 9/21/14 to 9/26/14, On Track (green) from 9/21/14 to 9/26/14, Completed (blue) from 9/21/14 to 9/26/14]																																								
4. Components Research/Selection	56 days	9/15/14	11/13/14	[Gantt bar: Started (black) from 9/15/14 to 9/22/14, On Track (green) from 9/15/14 to 10/13/14, To be Completed (grey) from 10/13/14 to 11/13/14, Completed (blue) from 11/13/14 to 11/13/14 with a Milestone diamond at 11/13/14]																																								
4.1 Induction Charging				[Gantt bar: Not On Track (yellow) from 9/15/14 to 10/1/14, On Track (green) from 10/1/14 to 10/13/14, To be Completed (grey) from 10/13/14 to 11/13/14]																																								
4.2 Locking Mechanism				[Gantt bar: Not On Track (yellow) from 9/15/14 to 10/1/14, On Track (green) from 10/1/14 to 10/13/14, Completed (blue) from 10/13/14 to 10/20/14, To be Completed (grey) from 10/20/14 to 11/13/14]																																								
4.3 Housing				[Gantt bar: Not On Track (yellow) from 9/15/14 to 10/1/14, On Track (green) from 10/1/14 to 10/13/14, Completed (blue) from 10/13/14 to 10/20/14, To be Completed (grey) from 10/20/14 to 11/13/14]																																								
4.4 Microcontrollers				[Gantt bar: Not On Track (yellow) from 9/15/14 to 10/1/14, On Track (green) from 10/1/14 to 10/13/14, To be Completed (grey) from 10/13/14 to 11/13/14]																																								

Budget Estimate

A. Personnel			
Engineer	Hours	Hourly Pay	Total Pay
Bryan Castro	348	\$30.00	\$10,440.00
Seve Kim	348	\$30.00	\$10,440.00
Bilal Rafiq	348	\$30.00	\$10,440.00
Justin Johnson	348	\$30.00	\$10,440.00
Jacob Knoblauch	348	\$30.00	\$10,440.00
		Personnel Subtotal	\$52,200.00
B. Fringe Benefits		29% of Personnel	\$15,138.00
C. Total Personnel			\$67,338.00

Budget Estimate

D. Expenses			
Item/Description	Quantity	Price/Unit	Total Price
Galvanized Steel Sheet (32 ft ²)	1	\$130.00	\$130.00
Four-Bar Robotic Claw Arm	1	\$50.00	\$50.00
Worm Drive Gearbox	1	\$60.00	\$60.00
81 RPM Gear Motor	1	\$25.00	\$25.00
Microchip PIC Ethernet Board w/ RS232 & Web-Based Configuration	1	\$72.00	\$72.00
Arduino UNO	1	\$18.50	\$18.50
22 AWG Copper Magnet Wire (1 lb, 507 ft)	1	\$16.50	\$16.50
14 AWG Copper Wire (25 ft)	1	\$14.00	\$14.00
LED R/Y/G	1	\$2.75	\$2.75
		Expenses Subtotal	\$388.75
E. Total Direct Costs		Personnel + Expenses	\$67,726.75
F. Overhead Costs		45% of Direct Costs	\$30,477.04
G. Total Project Cost			\$98,203.79

Summary

Mechanical components have been carefully selected for our design proposal

- Materials
- Locking mechanisms
- Additional features

Electrical components have been designed for efficiency and reliability

- Mainframe and bike controllers
- Electrical lines for power and LEDs
- Induction coils