

**FAMU-FSU College of Engineering**  
**Department of Electrical and Computer Engineering**

**SYSTEM-LEVEL DESIGN REVIEW**

**EEL4911C – ECE Senior Design Project I**

Project title: E-BIKE CHARGING AND DOCKING STATION

Team #: 7

Student team members:

- **Seve Kim**, Computer engineering (Email: [sk10j@my.fsu.edu](mailto:sk10j@my.fsu.edu))
- **Jacob Knoblauch** Computer engineering (Email: [jmk12h@my.fsu.edu](mailto:jmk12h@my.fsu.edu))
- **Bryan Castro** Electrical engineering (Email: [bzc10@my.fsu.edu](mailto:bzc10@my.fsu.edu))
- **Bilal Rafiq** Mechanical engineering (Email: [bdr11b@my.fsu.edu](mailto:bdr11b@my.fsu.edu))
- **Justin Johnson** Mechanical engineering (Email: [jj11d@my.fsu.edu](mailto:jj11d@my.fsu.edu))

Senior Design Project Instructor:

**-Dr. Mike Frank -Dr. Hellstrom -Dr. Tung**



Submitted in partial fulfillment of the requirements for  
EEL4911C – ECE Senior Design Project I  
November 14, 2014

# Executive Summary

The E-Bike charging and docking station being designed by Team 7 is intended to charge the electric bicycle provided by Efficient Systems LLC. and lock it securely with minimal user involvement. The overall design of the station has been modified, since the last proposal, after discussions with the project sponsor and careful re-evaluation of the project's subsystems. The new design still fulfills the goals and requirements of the project, while making the station more efficient and user friendly. The bike will still be placed in the station rear wheel first due to various factors, such as reducing the complexity of the design.

The major subsystems that have been modified include: structure, locking mechanism, and communication. The structure of the station was changed from being positioned on the right side of the bike to being positioned directly behind it. The new structure design provides a more sleek and aesthetically pleasing look for the station. The locking mechanism was changed from a gripper arm to an electromagnetic lock. In terms of communication, it was decided to use an RFID in order to communicate the bike's presence and ID with the main controller of the station. Also, a speaker was added to the design in order to provide the user with a form of audio communication on whether or not the bike is being correctly stationed.

This project is intended to be an innovative solution to solving the design problem provided by Efficient Systems LLC. The design will provide an efficient method for wirelessly charging the E-Bike's battery, automatically locking the bike, and operating through minimal user input. The system-level design review encloses all the details and a full analysis of the project design.

# Table of Contents

|  |    |
|--|----|
| Executive Summary .....                                      | 2  |
| Table of Contents .....                                      | 3  |
| 1 Introduction.....  | 5  |
| 1.1 Acknowledgements .....                                   | 5  |
| 1.2 Problem Statement.....                                   | 5  |
| 1.3 Operating Environment. ....                              | 5  |
| 1.4 Intended Use(s) and Intended User(s) .....               | 7  |
| 1.4.1 Intended Use(s). ....                                  | 7  |
| 1.4.2 Intended User(s). ....                                 | 7  |
| 1.5 Assumptions and Limitations .....                        | 7  |
| 1.5.1 Assumptions .....                                      | 7  |
| 1.5.2 Limitations.....                                       | 8  |
| 1.6 Expected End Product and Other Deliverables.....         | 8  |
| 1.6.1 Electric Bicycle Induction Charging Adapter (1).....   | 8  |
| 1.6.2 Electric Bicycle Charging and Docking Station (1)..... | 8  |
| 2 System Design.....   | 9  |
| 2.1 Overview of the System.....                              | 9  |
| 2.2 Major Components of the System.....                      | 10 |
| 2.2.1 Structural Material.....                               | 10 |
| 2.2.2 Overall Design of Structure.....                       | 10 |
| 2.2.3 Electro-Magnetic Lock.....                             | 10 |
| 2.3 Subsystem Requirements.....                              | 10 |
| 2.3.1 Structural Material.....                               | 11 |
| 2.3.2 Overall Design of Structure.....                       | 11 |
| 2.3.3 Electromagnetic Lock.....                              | 11 |
| 2.4 Performance Assessment.....                              | 12 |
| 2.4.1 Structural Integrity .....                             | 12 |
| 2.4.2 Aesthetic Appeal.....                                  | 13 |
| 2.4.3 Electromagnetic Performance.....                       | 14 |
| 2.5 Design Process.....                                      | 14 |
| 3 Design of Major Components/Subsystems .....                | 15 |
| 3.1 Mechanical Components .....                              | 15 |
| 3.1.1 Structural Material. ....                              | 15 |
| 3.1.2 Overall Design of Structure.....                       | 15 |
| 3.1.3 Electromagnetic Lock.....                              | 19 |
| 3.2 Electrical Components.....                               | 21 |
| 3.2.1 Induction Coils.....                                   | 22 |
| 3.2.2 Induction Cores.....                                   | 22 |
| 3.2.2 AC/DC Converter.....                                   | 22 |
| 3.2.3 Microcontroller.....                                   | 23 |

|         |  |    |
|---------|--|----|
| 3.2.3.1 | Networking.....                                      | 23 |
| 3.2.3.2 | RFID Reading/Writing.....                            | 23 |
| 3.2.3.3 | Microprocessor Interfacing.....                      | 24 |
| 3.2.4   | User Interface.....                                  | 24 |
| 3.2.5   | Electrical Lines.....                                | 24 |
| 4       | Schedule.....  | 24 |
| 5       | Budget Estimate.....                                 | 25 |
| 6       | Overall Risk Assessment.....                         | 28 |
| 6.1     | Technical Risks.....                                 | 28 |
| 6.1.1   | Hardware Risks.....                                  | 28 |
| 6.1.1.1 | Hardware Risk 1: Electromagnetic Lock Failure.....   | 28 |
| 6.1.1.2 | Hardware Risk 2: RF-ID Failure.....                  | 29 |
| 6.1.1.3 | Hardware Risk 3: Induction Plate Misalignment.....   | 30 |
| 6.2     | Schedule Risks.....                                  | 30 |
| 6.2.1   | Schedule Risk 1: Component Availability.....         | 30 |
| 6.2.2   | Schedule Risk 2: Component Delivery Time.....        | 31 |
| 6.2.3   | Schedule Risk 3: Technical Support Availability..... | 32 |
| 6.2.4   | Schedule Risk 4: Illnesses.....                      | 32 |
| 6.2.5   | Schedule Risk 5: Change of Design.....               | 33 |
| 6.3     | Budget Risks.....                                    | 34 |
| 6.3.1   | Budget Risk 1: Additional Support Costs.....         | 34 |
| 6.3.2   | Budget Risk 2: Unexpected Component Costs.....       | 35 |
| 6.3.3   | Budget Risk 3: Budget Mismanagement.....             | 35 |
| 6.4     | Summary of Risk Status.....                          | 35 |
| 7       | Conclusion.....                                      | 36 |
| 8       | References.....                                      | 37 |
|         | Appendices .....                                     | 38 |

# 1 Introduction

## 1.1 Acknowledgements

The design team gives salutations to Fabio Vargas and Maximo Mendoza, owners of Efficient Systems, for their contribution through monetary means as well as close mentorship and guidance, technical help and advice, and unrelenting support. The team is also grateful for both the ECE and ME project advisors, Dr. Michael P. Frank and Dr. Eric Hellstrom respectively.

## 1.2 Problem Statement

The design team was assigned the task of designing and building a charging and docking station for the Efficient Systems electric bicycle. The e-bike has already been developed and primitive charging and docking station was put into place. The problem with the primitive station design was that it required an excessive amount of user interaction. Said interaction being the need to manually plug a power source into the e-bike battery and use a manual lock to secure the e-bike. This creates a problem for the user in the sense of not being user-friendly and creating an inconvenience for the on-the-go commuter. The new design eliminate this problem by making the station for the e-bike to be an easy-to-use and quick way of charging and docking your e-bike. The station base will rear wheel orientated with a streamline design of an all inclusive, charge, lock, and dock in one centralized hub. When the rear wheel is backed into the station nook, a few processes take place. The structure design of the station allows the bike to be held steady and in place for an easy dock and undocking. The locking aspect is accomplished by an electromagnet on the underside of the station that will connect to the back wheel hub. The station will include an induction subsystem set up adjacent to the e-bike battery that will provide the e-bike charging.

## 1.3 Operating Environment

The environment to which this station will be operating and tested in will be outside in our current location of Tallahassee, FL. The climate which will allow testing of the station will most likely be late winter to early spring, so that there is a good range of high and low temperatures. Of course the stations will have to withstand the environment year round and the station will have to adapt to changing locations and altering conditions. The average high and low temperatures as well as average precipitation are given in the chart below:



Fig. 1.3: Monthly Averages of Temperature (°F) and Precipitation (in)

So the station will have to withstand a minimum temperature of roughly 35°F and a maximum temperature of roughly 95°F. The station will have to withstand rain at most for precipitation in our given conditions. The IP Code (International/Ingress Protection Marking) will be used for testing the liquid level of protection of the station. Specifically the station will have to meet the standards of IP4, which means it will be able to withstand a splash of water from any direction without having any harmful effects. The test duration will be 5 minutes with 10 L of water per minute at 80-100 kPa. The housing of the station base will be enclosed in a galvanized steel.

The material will be put under a series of stress analyses to simulate any forces that the station will incur.

## **1.4 Intended Use(s) and Intended User(s)**

### **1.4.1 Intended Use(s)**

The scope of the design project that was assigned includes the use of the station in the following processes: docking, locking, and charging the Efficient Systems electric bicycle. These intended uses will be applied to the designing and building of the station. As stated previously, the stations will be placed in a semi-public environment that will be accessible to the intended users. Currently, the presented scenario will be a company that owns Efficient System e-bikes and will make them accessible to their employees.

### **1.4.2 Intended User(s)**

The intended users of the station will generally be owners of the e-bikes. These users could vary in age, computer competency, and nationality. For children to teens to use the station, the station will have to be easy enough to put into place. On the other hand there are elderly citizens that might not be as competent when it comes to computer usage or maybe a foreign speaker that can't comprehend English, so the system will have to be as intuitive to use as possible.

## **1.5 Assumptions and Limitations**

### **1.5.1 Assumptions**

- All source components must meet the requirements to ensure minimal operation commitments:
  - The RFID tags attached to the e-bike will be sensed from a range of 100m when docked into the station.
  - The station structure housing will enclose all power and electrical components and efficiently protect from environmental constraints.
  - The station structure will include vertical support beams to improve stability and stress strength.
  - The main line wires will have a provided enclosure to and from the station to the source of power.
  - Inductive coils will need a large enough core to supply an efficient transfer of power.
  - The electromagnetic lock will have the capability to withstand 800 lbs (363 kg) of force.
- In order for the charging subsystem of the bicycle to work via induction, there must be an AC current flowing through the subsystem.
- The

### 1.5.2 Limitations

- The station must provide an automatic locking mechanism. (REQF-01)
- The station must be able to charge the battery (rated at 36V and 8 or 14A) within 3-4 hours by induction. (REQF-02)
- The station must have a user interface including LEDs and speaker. (REQF-03)
- The station must be capable of operating in temperatures approximately as high as 110 degrees Fahrenheit (43 C) and as low as 20 degrees Fahrenheit (-7 C). (ENVR-01)
- The electromagnetic has a strong enough force to harm the user, so the location of the lock on the station and on the bike will have to be considered for safety.

## 1.6 Expected End Product and Other Deliverables

### 1.6.1 Electric Bicycle Induction Charging Adapter (1)

This item is an adapter to the electric bicycle in order to enable inductive charging from the station to the e-bike battery. This eliminates the need for manual interaction from the user when placing the e-bike into the station. The adapter will have a 3D-printed casing to enclose the induction coil, core, AC/DC converter, RFID, and wires. The adapter will have a large surface area so when the bike is aligned with the station-side inductive plate, there is a clean juxtaposition of the inductive plates. The adapter will include the following items:

- Bike-side induction component (1)
- 3D-Printed housing (1)
- Battery-side plug (1)
- RFID tag(1)

### 1.6.2 Electric Bicycle Charging and Docking Station (1)

The charging and docking station will provide a seamless way for users to park their e-bikes and secure them safely while they charge at the same time. The provided end product will be fully operation of the exact specifications and requirements. The station unit comes complete with the following items:

- Station-side induction component (1)
- RFID Sensor (2)
  - User RFID sensor (1)
  - E-bike RFID sensor (1)
- 800 lb Electromagnetic lock



## 2 System Design

### 2.1 Overview of the System

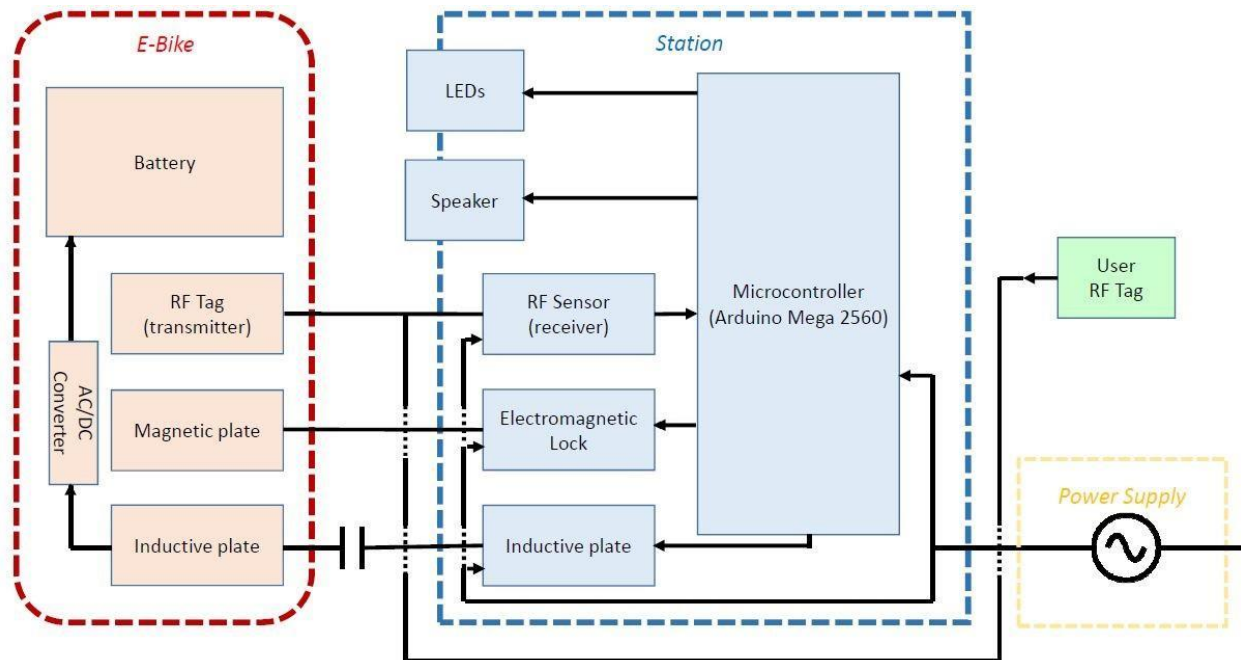

Fig. 2.1: Station Top Level Overview Design

The diagram above shows the internal system of the charging and docking station as well as the hardware components on the user, e-bike, and power source side. The station operates in the following manner:

- State 1: "Bike in use"
  - The Speaker, Lock, and Inductive plate are inactive when the RF Sensor does not sense the RF tag is not present. In short, if the e-bike is not in the station, nothing will operate.
  - The red LED will be lit to signify the bike is away from the station and in use.
- State 2: "Bike docked & charging"
  - Once the e-bike is brought into the proper docked position in the station, a few things will occur:
    - The Arduino Mega 2560 microcontroller will set the lock, and charge via inductive plate after it receives a signal from the RF Sensor that it has connected with the e-bike RF tag.
    - Before the electromagnetic lock turns on and connects to the magnetic plate on the bicycle, the speaker will notify the user, "Please keep hands and arms away from the station". This ensures the safety of the user is taken into consideration.

- The Arduino Mega 2560 microcontroller will set the inductive plate to start charging the bicycle across plate-to-plate and will convert the AC power to DC and charge the battery.
- The yellow LED lit up will indicate the e-bike is charging. While the e-bike is charging, the bike will not be able to be removed by a user.
- State 3: “Bike Ready”
  - Once the e-bike is fully charged, the green LED will light up.
  - The user will have his own RF Tag to notify the station to unlock the bike from the station.
  - This will disengage the electromagnetic lock and allow the user to take the e-bike.

## 2.2 Major Components of the System

### 2.2.1 Structural Material

The material was carefully chosen against the environmental and budget constraints. Galvanized sheet metal will be utilized as the main material for the entire charging and docking module. To reinforce the structure, steel rods will be utilized to build the internal frame to provide extra strength.

### 2.2.2 Overall Design of Structure

The station has been designed to provide the sensation of a sleek and modern appeal. The electric bikes are an innovative way of solving transportation issues while also reducing carbon emissions to the environment. The design was focused on communicating that message to the users. For marketing purposes, the design of station will be focused on providing the user with images and confidence that this is a modern day technology. Technology has always been appealing to people and the design of the station will communicate that feeling to the users.

### 2.2.3 Electro-Magnetic Lock

After carefully re-evaluating multiple options for locking and docking the bike, it was chosen to return back to a previous solution that had been dismissed. Electromagnetic locks are the easiest means to lock and unlock the bike with minimal user interaction. Previous designs involved too much reliability on the user to lock the bike which could pose an issue where the user might dock and not properly lock the bike leaving it susceptible to theft.

## 2.3 Subsystem Requirements

This section specifies detailed requirements (including quantitative specifications/constraints) on all of the major subsystems. Particularly important to include here are interface specifications (power requirements, digital signal/protocol specs, etc.) that designers of the other subsystems that interact with a given subsystem need to be aware of.

### **2.3.1 Structural Material**

Galvanized steel metal is resilient against weathering and provides the strength needed to keep the structure intact. The Gauge sizes for the sheet metal are used to describe the thickness but as the gauge increases, so does the costs. The gauge size was tested under FEA(Finite Element Analysis) to find the optimum gauge needed with also allowing a safety factor of 4. A factor of safety was not provided by the sponsor but it was concluded that the overall structure should be capable of withstanding greater forces that the station might encounter. Also the hardness of the sheet metal is also dependent on the gauge and will be tested after the thickness is selected to ensure it means the requirements. The forces used to run the FEA analysis were taken from a research that was conducted to observe the average human pulling and pushing force. The average male can provide a pulling force from a static position of about 200 lbf and less for a female. So the upper limit that will be tested to provide a factor of safety of 4 will be 800 lbf [2].

### **2.3.2 Overall Design of Structure**

The structural design needs to be sleek and deliver the message that this is an innovative technology. The forming to get the unique design of the structure will be difficult and tedious. Also while bending galvanized steel, the zinc coating can crack where the pressure has been applied making susceptible to corrosion. Since the projected plan is to paint the station green, the paint will be selected to have corrosive resistive properties to compensate for those areas needed.

### **2.3.3 Electromagnetic Lock**

The locking device needed to sustain a hold of greater than 200 lbs while also unlocking and locking in the most convenient and quickest way possible. The previous design incorporated levers or moving arms that would latch onto some part of the frame of the bike. The main issue was that the tolerances for attaching the bike were so small that the user would have to place the bike the exact spot or the locking device would not function correctly. The main focus of this project is to lock and unlock with minimal user input which our previous failed to meet. Switching to a electromagnetic lock eliminated most of the reliability for the user to properly place the bike and allowed for a quicker lock to unlock state and vice versa. Also the EM lock used should be sufficiently strong to hold up against theft and other outside forces. To meet a factor of safety of 4 the rated force should be 800 lbf. The lock should also consume power under 100 watts to keep the operating cost low. Also during power failure, the EM will attain its power from a backup power source that will be discussed later in risks.

## 2.4 Performance Assessment

Various components need to be tested to meet certain requirements and specifications. Each component will be tested to for its performance based on certain requirements that need to be met.

### 2.4.1 Structural Integrity

The structure was tested for stress using Finite Element Analysis(FEA) on Creo Parametric 2.0. The maximum force that the structure will endure is 800 lbf which will be applied in two directions. The first direction simulates if a force is applied to the station at a side force. The gauge used is 15(1.80 mm) and the selected material in the software is steel. The simulation is results for this situation is shown below in figure 2.4.1 A. The lighter blue indicates small stresses whereas the darker reds describe greater stresses. The simulation shows an even distribution of stress with no areas of concentration. This was almost consistent for every gauge size larger than the one chosen.

*Figure 2.4.1 A: Applied Force to the Side*

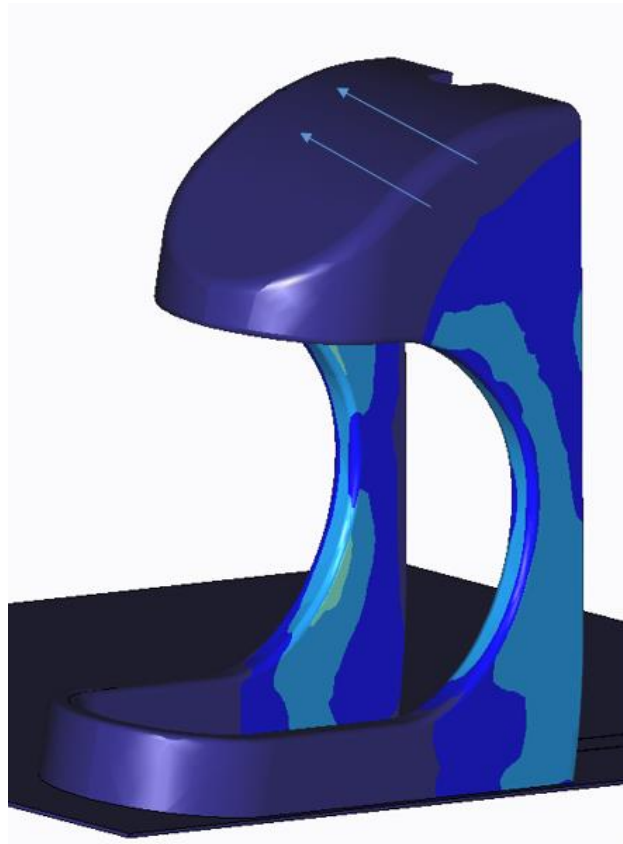

The next configuration of forces deal with the situation of a force to be applied in the front direction. Figure 2.4.1 B below shows the simulation results of 800 lbf being applied. The simulation shows stress concentrations where it was expected. The same stress concentrations

occurs with the force applied in the opposite direction. Also as the gauge size increases the stress does diminish but area of stress concentration is still of concern. A smaller gauge will pose a bigger issue and will dent easier. This poses a new issue that needs to be acknowledged and dealt with the best solution possible. Steel vertical support beams will be utilized as a frame to ensure that the structure does not fail at those points. These steel beams will be approximately 1 inch thick and will be anchored to the ground where the station will be installed.

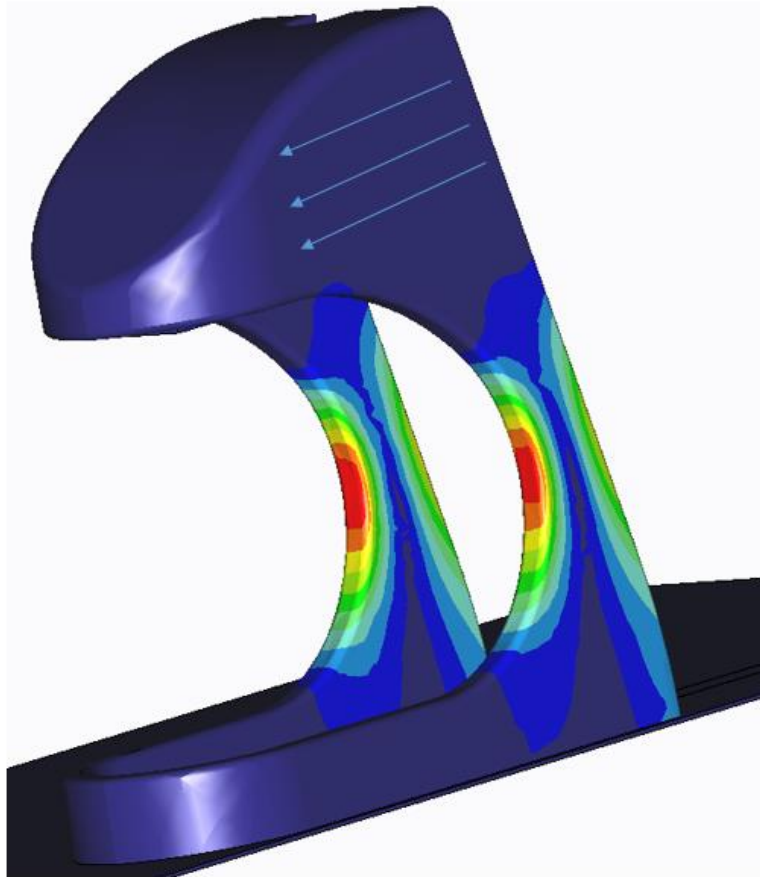

### 2.4.2 Aesthetic Appeal

The design will be evaluated for its aesthetic appeal by conducting a survey to rate the appearance on a scale from 1 to 10. A corresponding word or phrase will be noted for how the surveyors feel towards the design in response to viewing the design for the first time. Many of the surveyors thus far have given an approval and attributes to its modern appearance.

### 2.4.3 Electromagnetic Performance

The electromagnet chosen for the design must meet the minimum requirement of 800 lbf and also the power supplied must be low enough to not have a high operating cost. The power consumption of a standard electromagnet can be calculated to ensure it stays under 100 watts.

$$P = I * V \quad I = 0.25 \text{ Amperes} \quad V = 24 \text{ Volts}$$

$$\text{Power Consumed} = 6 \text{ watts}$$

The power consumption is well below and should pose an issue. However the orientation of the placement of the lock is critical to achieving the EM locks optimum force. The lock was chosen to attach at a 45 degree angle to better distribute the forces along the contact and as well as the reaction forces throughout the station

## 2.5 Design Process

While the different configurations and styles were considered, there were a few specific attributes the station had to have. Since it will be outdoors and in a parking lot or near buildings, the overall station had to be compact and still retain its form during certain conditions of weathering and human interaction. Also, the design was carefully chosen to implement a locking feature with minimal input from the user. The least amount of input would simply be to guide the bike into a slot or contraption to lock. The design encompasses this feature with the use of an electromagnet to attach to a plate that will be bolted to the bike rack behind the seat. The stations charging capabilities will be achieved by using an induction coil inside the station. After the user has successfully placed the bike in position and the EM lock has been activated, the induction plate will actually extend out to the bikes induction plate to increase the power transfer efficiency. This will be implemented by using a rail system with a low speed and low torque motor. In addition, the station will communicate various visual and sound indicators to express when the bike is ready to be used or not and to also notify the user if they have not properly placed the bike for the lock feature.

The station will also need to have networking capability in order to communicate the status of the bikes to the main server which acts as the primary user interface. Each bike will have the ability to interface with other bikes in the set of stations in order to send their individual status to the station with networking capability. In order to unlock the bike, an RFID tag can be swiped on the reader, or the user can reserve a bike through the website that networks with the station. All of these systems will be controlled and monitored through the use of a microcontroller on each bike, and the stations will be connected by an electrical line for power and communication.

## 3 Design of Major Components/Subsystems

### 3.1 Mechanical Components

#### 3.1.1 Structural Material

The galvanized sheet metal will be purchased from a vendor in the city of Tallahassee. The steel support beams for the frame will also be purchased from these same vendors. The sheets will be provided as in figure 3.1.1. The steel will need to be cold worked an order to shape the metal for the unique design. This will be done at the machine shop as well as any fabrication or drilling needed.

*Figure 3.1.1: Commercial Galvanized Sheet Metal*

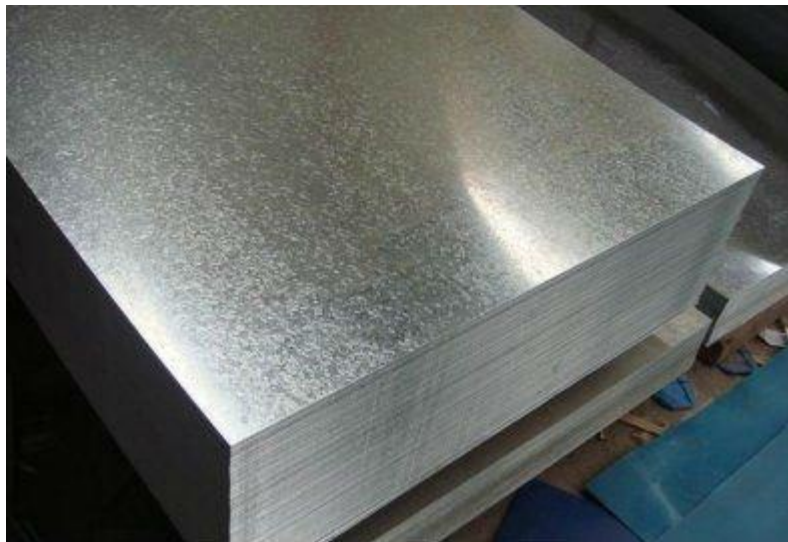

#### 3.1.2 Overall Design of Structure

The virtual design of the station was created on PTC Creo Parametric 2.0 because of its flexibility of creating parts that are unique in geometries. The overall size of station is shown with comparison to a 6'1" ft manikin in figure 3.1.2 A. The station has a relatively low profile which allows for a low center of gravity making the station stronger during torque loads on or near the top of the station. In figure 3.1.2 B the station shown from the front view indicates the space needed to fit the pedals inside the station. The station size is roughly 1.06 m tall and the total square footage of sheet metal needed is around 1.4  $m^2$ .

*Figure 3.1.2 A: Side View With 6'1" Mannequin*

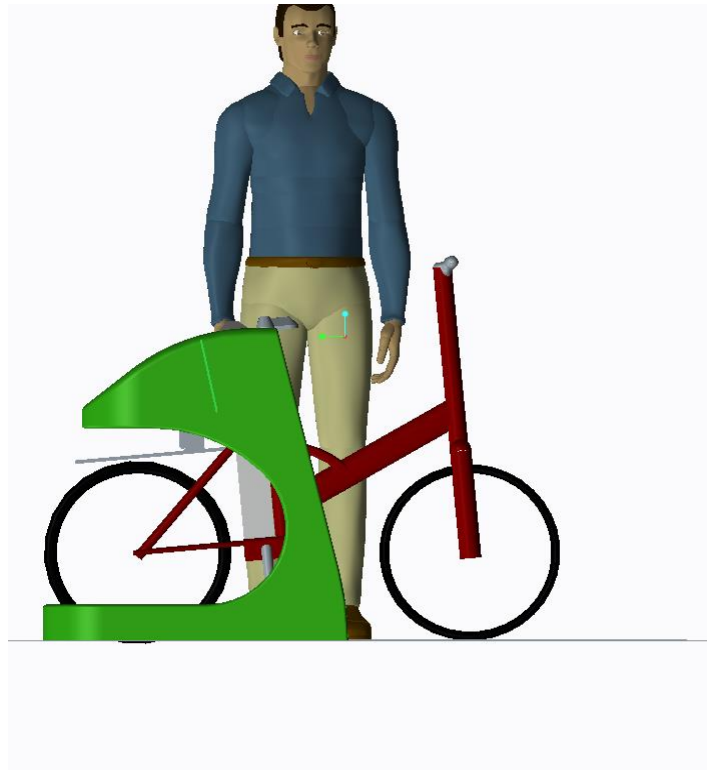
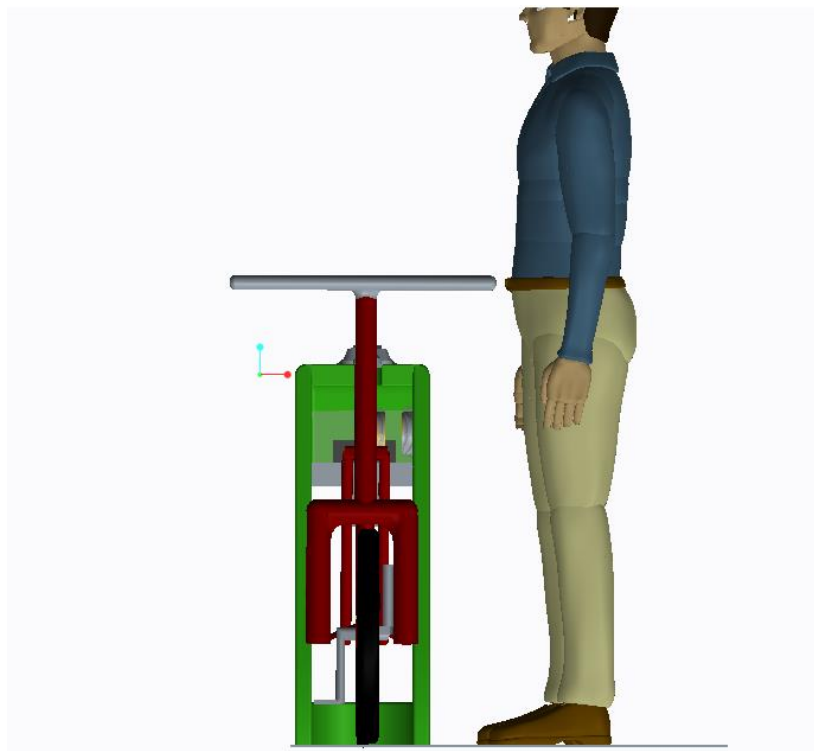

Figure 3.1.2 A: Front View With 6'1" Mannequin





In figure 3.1.2 C, the stations internals are hidden and are placed in a compartment. The internals, this includes the housing for the electrical components, the EM lock, and any wiring needed to distribute power to any of the sources, will all be enclosed in the region where the electrical component housing is located. The opaque region before the storage compartment will be a latched door that can be locked and unlocked using a standard key. This will be utilized in the situation of the station malfunction and also will make the installation of the components easy to access. The induction plate in its non extended state is also seen in the figure. Also the seat will fit into a slot that will assist the user in guiding the bike into the correct orientation for the EM lock to make full contact.

*Figure 3.1.2 C: Close Up View of Station Components*

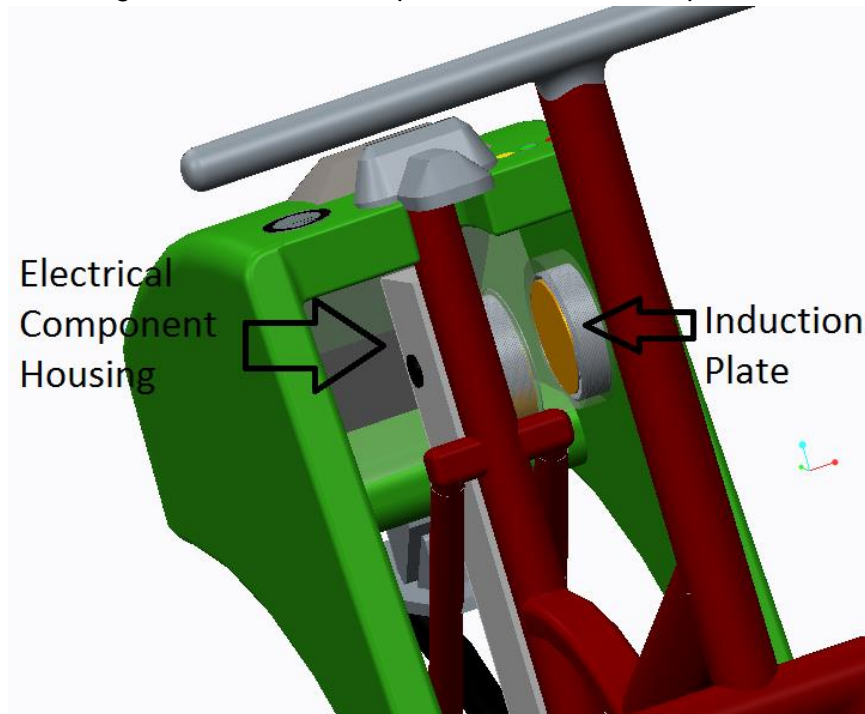

In figure 3.1.2. D the top view of station displays all of the key features the user will utilize to assist and communicate to them. The RFID sensor will be located near the seat aligner to bring the bikes RFID chip close to the sensor to identify the bike to the users RFID. A speaker to the left will communicate to the user when they have not yet placed the bike properly to lock it into place. It will also communicate directions to the user if they help understanding the steps to complete the process of locking or unlocking the bike. The LED indicators will display green for when the bike has been unlocked and ready to use, red for when the bike has successfully locked or still locked, and finally yellow if the bike is out of service. The red light will blink and as well as the speaker will communicate to the user to identify and fix the issue. Finally the guiding strip will assist the user to bring the bike in at the correct orientation for the docking feature to begin.

*Figure 3.1.2 D: Top View of Station*

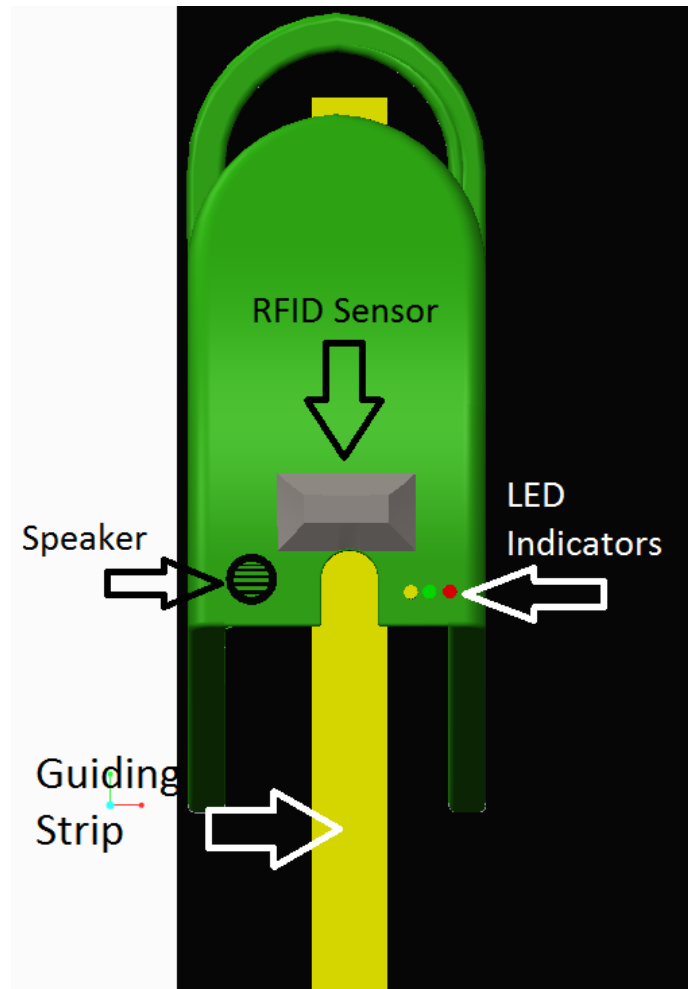

During the locked state, the induction plate on the station side will be driven out to the induction plate on the bike side. This will increase the efficiency greatly because magnetic power dissipates at a proportion of  $\frac{1}{R^3}$ . Therefore the closer they are, they better the power transfer. In figure 3.1.2 E, the induction plate can be seen fully extended almost making contact with the bike induction plate. To achieve this extension, the iron core will be attached to a mount that has threads to be driven by a stepper motor that has an extended threaded rod. The stepper motor will be controlled and activated by the main microcontroller and will be tested to find the exact output to deliver the induction plate to the correct length. Figure 3.1.2 F shows the type of threaded rod attachment that will be used. It is a 28 cm rod but can be found in various sizes [5]. Since speed will not be an issue of extending the plate. The stepper motor will be selected to carry a high torque due to the weight of the iron core and coils.

*Figure 3.1.2 E: Induction Plate Extended*

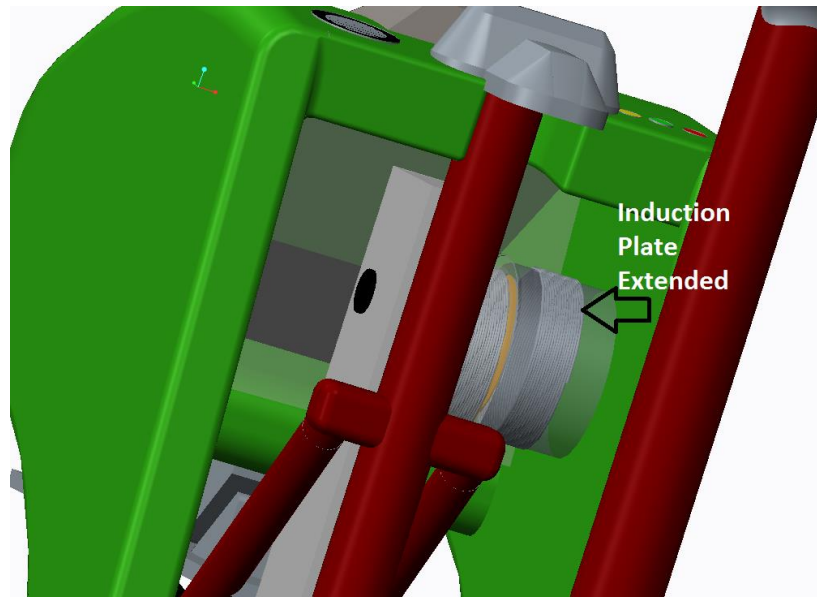

Figure 3.1.2 F: Stepper Motor With Threaded Rod Attachment



### 3.1.3 Electromagnetic Lock

The EM lock chosen had to have a few key features for it to be suitable for our requirements. The lock has to be made out of non corrosive material to be able to withstand weathering conditions and to be reliable during heavy wind conditions. The rating for the EM lock chosen was 800 lbf because of the price not being to drastically high compared to the 600 lbf EM locks. Also the EM lock has a very low power consumption which is ideal for our design. The FPC-

SS800-G EM lock is the model that has been selected to purchase at this moment. The selected EM lock can be seen in figure 3.1.3 A accompanied with its simple circuit diagram in figure 3.1.3 B. The purchase does not include a plate but the plate can be bought separately and needs to be modified to fit the area where the plate will be bolted. It will be bolted to the basket carrier on the back side of the bike. The placement of the metal plate and the stations electro magnet can be seen in figure 3.1.4 C.

Figure 3.1.3 A: Electro magnet



Figure 3.1.3 B: Circuit Diagram

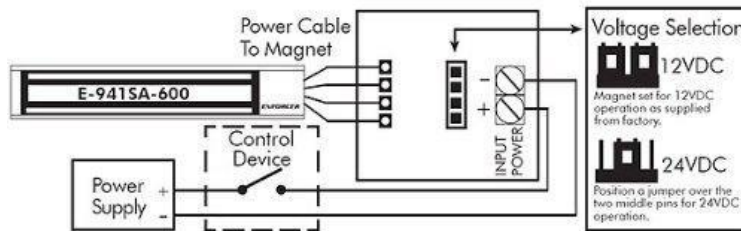
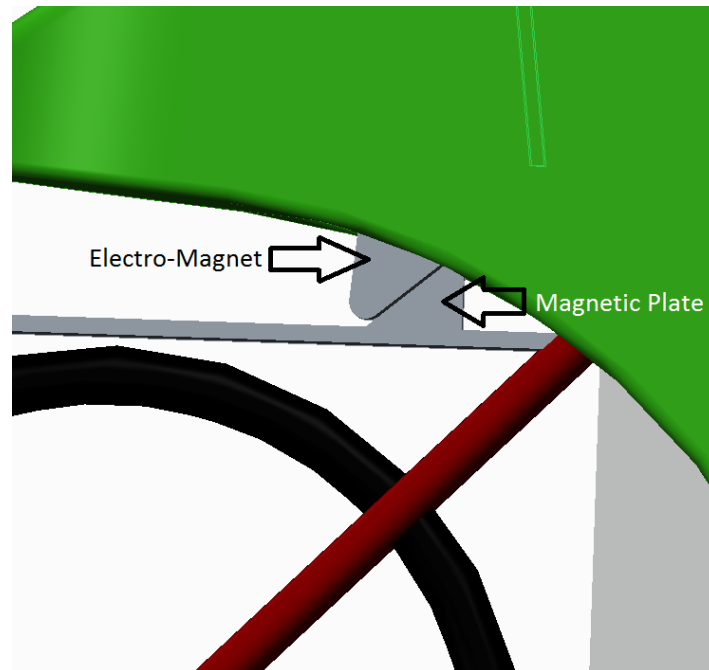
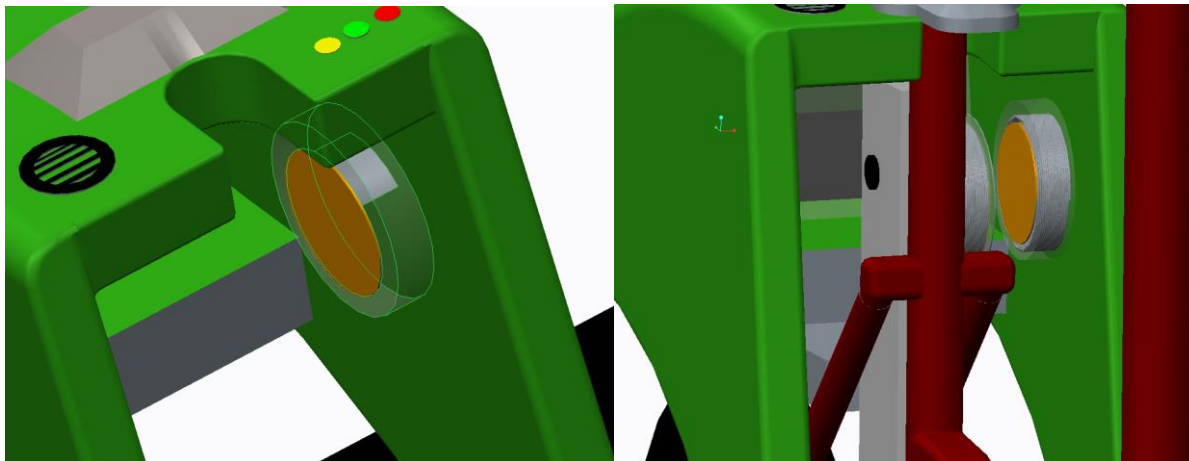

Figure 3.1.3 C: Contact Between Plate and EM



As shown in figure 3.1.3 C the EM and magnetic plate will both be angled at a 45 degree angle. This will ensure to the user when to stop guiding the bike in and when the two plates have made contact. If the plates were flat instead, the main force from the EM would than be relying on friction force instead of only the magnetic force which would decrease the force drastically. Instead it has been chosen to be angled instead of vertical because the bike rack can still be utilized while the plate on the bike side is angled.

## 3.2 Electrical Components



*Fig. 3.2.1: (Left) Station-side induction plate  
(Right) Bike docked in station with both plates together*

### 3.2.1 Induction Coils

The method chosen for charging the bike was induction due to it not needing metal-to-metal contact. This both improves user-friendliness and allows the electrical components to be covered, protecting them from damage and corrosion.

The bike-side induction coil will be integrated into the battery casing on the opposite side of the charging port. The coil will then be connected to the AC/DC converter and then connected in parallel to the charging port. The station-side induction coil will be housed on the inside of the enclosure and will be extended by a motor to meet with the bike-side inductor. The smallest possible distance between the two coils will be needed to achieve an ample power efficiency.

### 3.2.2 Induction Cores

In order to attain the efficiency needed to charge the bike battery through induction, ferromagnetic cores will be used for each of the coils. The plates as a whole will be the maximum size that is possible to fit within the space on the side of the battery. The total circular area available is approximately 95mm. As such, the core will be a disk 80mm in diameter, which leaves a cross-sectional area of 15mm for the wrapping of wire, which, assuming a wire gauge of 14 AWG, will allow for approximately 100 turns of wire. Theoretical calculations show that at least roughly 25 turns are needed in order to provide the needed power to the secondary coil.

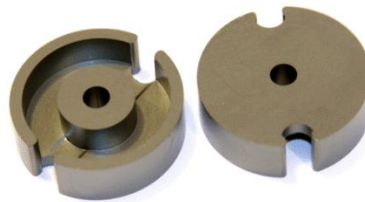

*Fig. 3.2.2: Example set of cores that could be potentially used for the induction coils*

### 3.2.2 AC/DC Converter

Because the battery runs on DC and the induction coils must run on AC, an AC/DC converter is needed. An AC/DC converter typically consists of a rectifier circuit to convert the input signal into an all-positive signal, then a filter circuit to smooth the voltage to a constant value. However, because the converter that comes with the bike battery also appears to cut off the power supply and monitor the capacity of the battery, designing a circuit with similar functionality would be beyond the scope of the project. Attempting to design one's own circuit could also lead to damage of the battery or even the bike. As such, the provided AC/DC converter will be used, but will be incorporated into a 3D-printed case for the battery.

### 3.2.3 Microcontroller

The main functionalities that are needed for the microprocessor on the station are networking capability, RFID reading and writing, interfacing with microcontrollers on other stations, and general control of outputs for the station including sending power and controlling the LEDs. The microcontroller chosen that fulfills all of these tasks is the Arduino Mega 2560 Rev3, which features enough ports to drive all of the aforementioned signals at once, as well as plenty of



memory and processor speed to handle the computations in a timely manner.

*Fig. 3.2.2: (Left) Arduino Mega 2560 Rev3; (Right) Arduino UNO Rev3*

Because the station as a whole needs only one microcontroller with networking capabilities, the other microcontrollers will have much fewer ports used and less memory required, and thus an Arduino UNO Rev3 should be suitable for each of the other stations. These microprocessors will have only the RFID module and the general ports for outputting the power to the bike and LEDs.

### 3.2.3.1 Networking

The station as a whole needs to be able to interface with an external website for communication of the status of the bikes in the station. The website will be the user's main method for renting a bike (the other method being using an RFID tag), and when a user rents a bike through the web interface, a certain bike will be unlocked assuming one is available. Furthermore, the bike station needs to send to the website when a bike has been undocked or docked in order to update the master status of all of the bikes. As such, the Arduino Mega will be equipped with an Ethernet Shield to connect to and transfer and receive information to and from the website, which should allow the microprocessor to accomplish all networking needs.

### 3.2.3.2 RFID Reading/Writing

Each bike will be assigned their own unique ID in order to track which bike is rented out, which is being returned, and in the case of damage or theft of the bike, a history of the previous renters. In order to accomplish this, the Mifare MFRC522 RFID Reader/Writer module will be added to the Arduino Mega. This module is able to both read and write RFID tags, the latter of which may be useful for resetting the ID of each bike to a new value when it is docked as an additional security measure.

Furthermore, RFID tags can come in nearly any shape or form, making them easy to fit into the specific needs of the design. For instance, the planned RFID tag for the bike is a sticker that can be attached below the seat of the bike and that can be read when the bike seat gets close to the



RFID scanner on the station. The user tags can come in whatever form they would like and could be available in an assortment for them to select.

### 3.2.3.3 Microprocessor Interfacing

Since only one microprocessor will have networking capability, each of the connected stations will need to be able to interface with it to send and receive data on the status of their respective bikes. This will be done using an SPI bus so that communication can be done in both directions.

### 3.2.4 User Interface

A user interface of some sort will be implemented in the final design to provide the user with information of the status of the station and bike. The current design implements a simple set of three LEDs that show whether the bike has been rented out, the bike is in the station but is charging, or the bike is fully charged and ready to be undocked.

### 3.2.5 Electrical Lines

As stations are added to a system, the new stations will need to communicate with the existing ones, so a transmission line will be run between the stations. These lines will connect a central power line to each of the individual induction coil lines, and communication lines will run between adjacent stations. The main power line will be of a larger wire size, such as 10AWG for a system with 5 or fewer total bikes, and the communication lines will be 20AWG or smaller since there will be very little current load on those wires.

## 4 Schedule

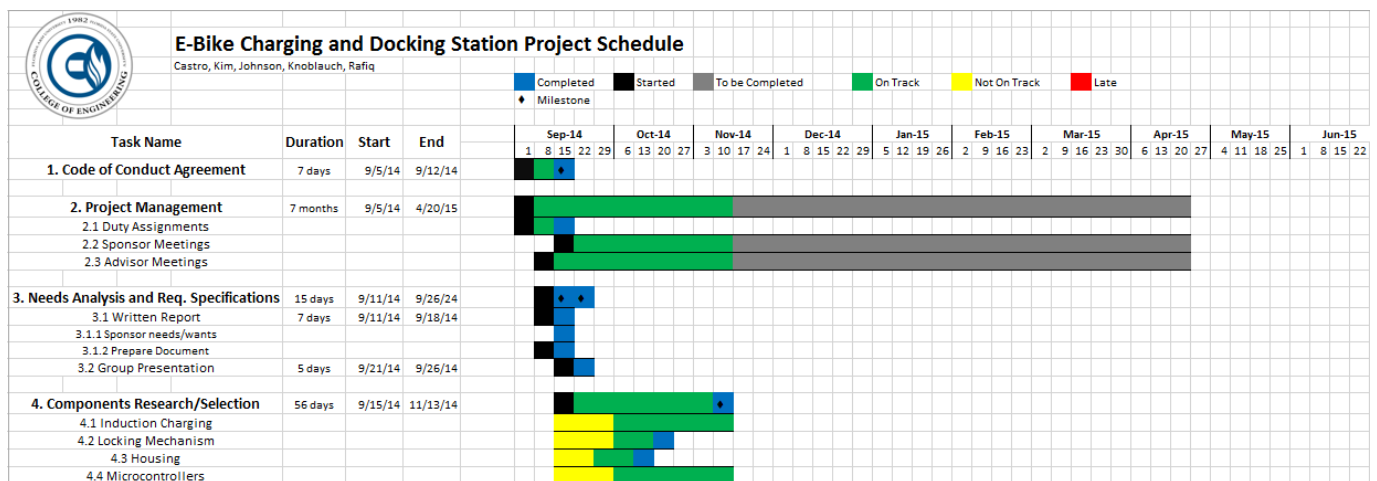



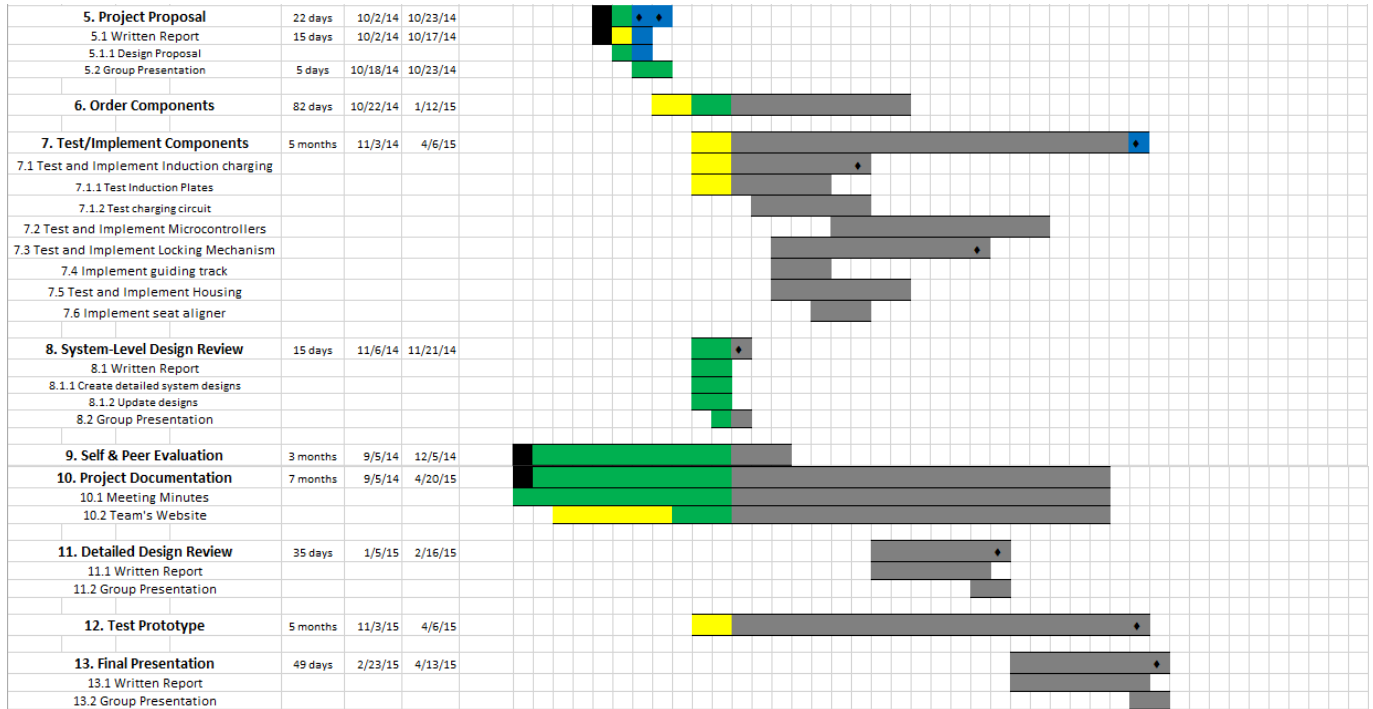

Any tasks that fall behind schedule will be addressed by coming together as a group and focusing on the given tasks. The quickest and most efficient method to get on track will be established as a group and all subtasks will be divided equally amongst each other. Early completion of tasks will be capitalized on by concentrating on any tasks that are behind or starting on another task with an approaching end date. Also, the tasks with the highest priority will be taken into consideration first.

## 5 Budget Estimate

### Original Budget:

| A. Personnel    |       |            |             |
|-----------------|-------|------------|-------------|
| Engineer        | Hours | Hourly Pay | Total Pay   |
| Bryan Castro    | 348   | \$30.00    | \$10,440.00 |
| Seve Kim        | 348   | \$30.00    | \$10,440.00 |
| Bilal Rafiq     | 348   | \$30.00    | \$10,440.00 |
| Justin Johnson  | 348   | \$30.00    | \$10,440.00 |
| Jacob Knoblauch | 348   | \$30.00    | \$10,440.00 |

|   |                 |                             |                    |
|---|-----------------|-----------------------------|--------------------|
|   |                 | <b>Personnel Subtotal</b>   | <b>\$52,200.00</b> |
| <b>B. Fringe Benefits</b>                                       |                 | <b>29% of Personnel</b>     | <b>\$15,138.00</b> |
| <b>C. Total Personnel</b>                                       |                 |                             | <b>\$67,338.00</b> |
| <b>D. Expenses</b>  |                 |                             |                    |
| <b>Item/Description</b>   | <b>Quantity</b> | <b>Price/Unit</b>           | <b>Total Price</b> |
| Galvanized Steel Sheet (32 ft.- <sup>2</sup> )                  | 1               | \$130.00                    | \$130.00           |
| Four-Bar Robotic Claw Arm                                       | 1               | \$50.00                     | \$50.00            |
| Worm Drive Gearbox  | 1               | \$60.00                     | \$60.00            |
| 81 RPM Gear Motor   | 1               | \$25.00                     | \$25.00            |
| Microchip PIC Ethernet Board w/ RS232 & Web-Based Configuration | 1               | \$72.00                     | \$72.00            |
| Arduino UNO   | 1               | \$18.50                     | \$18.50            |
| 22 AWG Copper Magnet Wire (1 lb, 507 ft)                        | 1               | \$16.50                     | \$16.50            |
| 14 AWG Copper Wire (25 ft)                                      | 1               | \$14.00                     | \$14.00            |
| LED R/Y/G   | 1               | \$2.75                      | \$2.75             |
|   |                 | <b>Expenses Subtotal</b>    | <b>\$388.75</b>    |
| <b>E. Total Direct Costs</b>                                    |                 | <b>Personnel + Expenses</b> | <b>\$67,726.75</b> |
| <b>F. Overhead Costs</b>  |                 | <b>45% of Direct Costs</b>  | <b>\$30,477.04</b> |
| <b>G. Total Project Cost</b>                                    |                 |                             | <b>\$98,203.79</b> |

## Updated Budget:

|                     |  |  |  |
|---------------------|--|--|--|
| <b>A. Personnel</b> |  |  |  |
|---------------------|--|--|--|

| <b>Engineer</b>   | <b>Hours</b>    | <b>Hourly Pay</b>         | <b>Total Pay</b>   |
|---|-----------------|---------------------------|--------------------|
| Bryan Castro  | 348             | \$30.00                   | \$10,440.00        |
| Seve Kim  | 348             | \$30.00                   | \$10,440.00        |
| Bilal Rafiq   | 348             | \$30.00                   | \$10,440.00        |
| Justin Johnson  | 348             | \$30.00                   | \$10,440.00        |
| Jacob Knoblauch   | 348             | \$30.00                   | \$10,440.00        |
|   |                 | <b>Personnel Subtotal</b> | <b>\$52,200.00</b> |
| <b>B. Fringe Benefits</b>   |                 | <b>29% of Personnel</b>   | <b>\$15,138.00</b> |
| <b>C. Total Personnel</b>   |                 |                           | <b>\$67,338.00</b> |
| <b>D. Expenses</b>  |                 |                           |                    |
| <b>Item/Description</b>   | <b>Quantity</b> | <b>Price/Unit</b>         | <b>Total Price</b> |
| Galvanized Steel Sheet Metal (1.41 m <sup>2</sup> )                           | 1               | \$88.48                   | \$88.48            |
| A36 Hot Rolled Steel (8 ft, 1 in Diameter)                                    | 1               | \$32.00                   | \$32.00            |
| FPC-SS800-G 800 lbs Outdoor and Gate Electromagnetic Lock CE Listed           | 1               | \$87.73                   | \$87.73            |
| Arduino UNO Rev3  | 1               | \$24.97                   | \$24.97            |
| Arduino MEGA 2560 Rev3  | 1               | \$43.70                   | \$43.70            |
| Arduino Ethernet Shield Rev3 (without PoE Module)                             | 1               | \$36.21                   | \$36.21            |
| Mifare RC522 Card Read Antenna RF Module RFID Reader IC Card Proximity Module | 1               | \$5.36                    | \$5.36             |
| Wall Adapter Power Supply (9VDC, 650mA)                                       | 1               | \$5.95                    | \$5.95             |
| 3" Diameter Speaker (8 ohm, 1 Watt)   | 1               | \$1.95                    | \$1.95             |
| Tool Storage Spring Terry Clips (1 in)  | 1               | \$10.19                   | \$10.19            |
| 18 AWG Copper Magnet Wire (1 lb, 201 ft)                                      | 1               | \$16.50                   | \$16.50            |

|                              |   |                             |                    |
|------------------------------|---|-----------------------------|--------------------|
| 14 AWG Copper Wire (25 ft)   | 1 | \$14.00                     | \$14.00            |
| LED R/Y/G                    | 1 | \$2.75                      | \$2.75             |
|                              |   | <b>Expenses Subtotal</b>    | <b>\$369.79</b>    |
| <b>E. Total Direct Costs</b> |   | <b>Personnel + Expenses</b> | <b>\$67,707.79</b> |
| <b>F. Overhead Costs</b>     |   | <b>45% of Direct Costs</b>  | <b>\$30,468.50</b> |
| <b>G. Total Project Cost</b> |   |                             | <b>\$98,176.29</b> |

## 6 Overall Risk Assessment

### 6.1 Technical Risks

#### 6.1.1 Hardware Risks

##### 6.1.1.1 Hardware Risk 1: Electromagnetic Lock Failure

###### Description

The electromagnetic lock will be the sole mechanism keeping the e-bike secure and preventative of theft. The electromagnetic lock will require 12VDC/24VAC in order to for the magnet to provide a continuous magnetic force. In the event that the main power source is cut due to a power surge in a storm possibly, or damage is done to the main line and wires, the lock is prone to failure. The e-bike will have no way of being secured and is open to theft.

###### Probability: Moderate

The stations will be placed in public areas that make it open to unpredictable environmental occurrences such as storms. Another possibility could be damage to the wiring or the actual source which will cause the lock to fail.

###### Consequences: Severe/Catastrophic

The e-bike itself costs close to \$1300 USD. The cost of replacement alone shows for the loss of the consumer as well as for the company.

### Strategy

The idea of the station locations will be near high rise buildings. Most of these high rise builds have a back up power generator. It would be an investment to inquire about a monthly charge to utilize these back up power generators to ensure that this risk does not occur. Another plan would be to have an internal battery supply for back up in the event of a power failure.

### **6.1.1.2 Hardware Risk 2: RF-ID Failure**

#### Description

The subsystems of the station heavily rely on the fact of whether or not the bike is in the station. The RF-ID tag and sensor are the reason the station can detect this. In the event that the sensor or the RF-ID tag malfunction or get damaged at all, the station will not lock the e-bike up or allow an already locked up e-bike to be released for use.

#### Probability: High

The RF-ID tag on the bike could possibly get damaged from use of the e-bike. The tag has the possibility of getting knocked off the e-bike. The RF-ID sensor has the possibility of malfunctioning when the tag isn't in the range of the sensor.

#### Consequences: Moderate

Since the station cannot operate without the status of the bike presence, the e-bike will be vulnerable to a user mistakenly leaving the e-bike unknowingly that it is not secured. On the flip side the e-bikes can't be unlocked and used. This can create an extreme amount of troubleshooting for ensuring the bikes are available to use and charged and locked.

### Strategy

In the event that these components do fail, it is best to have the system analyze the RF components and ensure the user is notified when the e-bike is not detected or locked after an attempted dock. If the bike is locked status and the RF-ID User tag is not functioning properly, the user will also have to be prompted the unlocking attempt has failed. Making the station user-friendly and responsive will be very important to this risk.

### **6.1.1.3 Hardware Risk 3: Induction Plate Misalignment**

#### Description

In order for the battery to receive a charge from the power source, the induction plates need to align to induce the most effective transfer possible. If these plates do not align correctly, the use of the e-bike is jeopardized.

#### Probability: Moderate

Given that there are “guidance tracks” to help the user place the e-bike in the correct position, a properly positioned magnetic lock, and a spring terry clip to prevent the e-bike from moving, this should not be much of an issue in theory. But considering that the user does not move the e-bike in the proper position, the charging and locking can not operate.

Consequences: Moderate

Since the station cannot operate without the status of the bike presence, the e-bike will be vulnerable to a user mistakenly leaving the e-bike unknowingly that it is not secured. On the flip side the e-bikes can't be unlocked and used. This can create an extreme amount of troubleshooting for ensuring the bikes are available to use and charged and locked.

Strategy

This can be prevented in the case of properly designing the placement of the plate to match up exactly with the bike plate in conjunction with the rest of the system. So making sure that in order for the seat-post to clamp into the spring terry clip, and the electromagnetic lock to reach the magnetic plate, all components on bike-side to station-side alike must.

## 6.2 Schedule Risks

There are many unplanned schedule related risks possible during the course of the project that can directly impact the project being completed on time. Some possible risks include availability of components on the market, delivery time of components, availability of technical support, illnesses, and change of design.

### 6.2.1 Schedule Risk 1: Component Availability

Description

Some of the necessary components for the design may not be in stock on the internet or in stores and could delay the schedule for testing of any subsystems or creating the prototype. Also, one of the components may need to be custom built and could take some time to become available to the group. Lack of availability may also risk one of the reports being completed on time. For example, a section in the report may need to analyze one of the systems that has a missing component so it would not be possible to fully complete that section.

Probability: Low

The probability of a component not being available to the group is low because one can usually find the same component on various websites or in various stores. The only main factors for causing this risk would be a component being out of stock or having to be custom built.

Consequences: Severe

If this risk were to occur there would be a severe impact on the overall performance of the project because most of the components play a vital part in one of the subsystems of the design. If one of the components were not available it would hinder the progress of testing and prototyping the subsystem it is a part of. It could also impact the amount of details available in a report when writing about a subsystem missing a component.

#### Strategy

The strategy to be used to manage this risk is finding all components in various places to order from, if possible, and ordering them in a timely manner. Also, it would be helpful to only use components readily available on the market and avoid anything that needs to be custom built.

### **6.2.2 Schedule Risk 2: Component Delivery Time**

#### Description

Some of the components for the design may not be in stock or it may be shipping from a far state or country. Also, they may not be available for expedited shipping if the component is needed last minute and it could delay implementing the component into the subsystem it is needed for.

#### Probability: Moderate

The probability of a component not being delivered in a timely manner is moderate because some components needed are not very common and usually ship from somewhere across the country or out of the country. There is also no way to control the efficiency of the delivery company so if there are any problems with the shipment nothing can be done to speed up the process.

#### Consequences: Moderate

If this risk were to occur there would be a moderate impact on the overall performance of the project because most of the components play a vital part in one of the subsystems of the design. However, it is different from the component not being available because the component will still be received, but not in the expected time frame. If one of the components were received late it may hinder the progress of testing and prototyping the subsystem it is a part of.

#### Strategy

The strategy to be used to manage this risk is placing all orders well ahead of time so that if there are any problems there is still time to make up for any loss time. Also, it would be helpful to order components from the closest location possible in order to cut down on delivery time.

### **6.2.3 Schedule Risk 3: Technical Support Availability**

#### Description

The lack of availability of technical support could be a risk in terms of building the structure of the station. The machine shop will be needed to correctly weld and put together the steel structure of the station. If it is not available then it would not be possible to put together the station's structure given the lack of experience of the group with welding steel.

Probability: Low

The probability of technical support not being available is low because if there is no personnel or space available for using the machine shop at the College of Engineering to weld the steel structure, then the group can reach out to a local machine shop to complete the given tasks.

Consequences: Catastrophic

If this risk were to occur there would be a catastrophic impact on the overall performance of the project because it would not be possible to correctly build the structure of the station given the lack of machinery and personnel with experience.

Strategy

The strategy to be used to manage this risk is coordinating with the machine shop well ahead of time to use it for building the station's structure. It could also be avoided by having a backup plan to use a local machine shop to build the steel structure.

## **6.2.4 Schedule Risk 4: Illnesses**

Description

The possibility of one of the group members becoming ill during the year could be a risk for completing tasks. If one of the members becomes very ill and is not able to work on the project, then the tasks given to that member have to be delegated amongst everyone else. This adds a larger work load to all members and could affect the ability to complete certain tasks on time.

Probability: Low

The probability of a group member becoming ill is low because everyone is in relatively good health and they maintain a healthy lifestyle. There is always the small possibility of at least one member becoming sick during this time period from an illness going around, especially during the winter time.

Consequences: Minor

If the risk were to occur there would be a mild impact on the overall performance of the project because it would cause other group members to take responsibility of the tasks not able to be completed by the ill member. If the tasks are fairly distributed in a timely manner, then there should be a very small impact of this risk on the group's performance.

Strategy

The strategy to be used to manage this risk is to avoid becoming sick during this time period by staying healthy and avoiding any airborne diseases. It is also important to become aware of an



ill group member as soon as possible so that they can start fighting off the illness and so their tasks can be divided amongst the rest of the group.

### **6.2.5 Schedule Risk 5: Change of Design**

#### Description

The possibility of having to make a small or large change of design could be a risk in terms of completing certain tasks for the project. For example, if the locking mechanism design has to be changed, then the whole subsystem has to be reanalyzed, tested, and prototyped. This process could take a while depending on the severity of the change and it could delay the completion of the prototype or even one of the reports. The point in time during which a change could occur also plays a huge factor on the risk's effect.

#### Probability: Low

The probability of a change of design during the course of the project is low because most design ideas have been thoroughly analyzed and are projected to work as expected; therefore, the design should not be changed until proven otherwise. There is the possibility that one of the design ideas does not produce the intended result once prototyped, and In that case a change has to occur.

#### Consequences: Severe

If the risk were to occur there would be a severe impact on the overall performance of the project because it would delay the completion of certain tasks like building the prototype and finishing any reports that encompass details of the design. If the change were to occur during the prototype phase, it would impact the ability to complete this task in a timely manner because the change would have to be reanalyzed and tested. If new components have to be ordered the delivery time could cause a delay as well.

#### Strategy

The strategy to be used to manage this risk is to minimize the possibility of having a change of design by thoroughly analyzing all design ideas the first time around so that when all subsystems for the project are being built there is no need to replace any of them. All design ideas should be planned to work as expected.

## **6.3 Budget Risks**

There are many unplanned budget related risks possible during the course of the project that can directly impact the project and produce budget overruns. Some possible risks include additional support costs, unexpected component costs, and mismanagement of budget.

### 6.3.1 Budget Risk 1: Additional Support Costs

#### Description

There is the risk of having to add costs to the budget for additional support. This would be an unexpected addition to the budget since it is not planned to have any part of the budget set aside for additional support. For example, if the plan to use the machine shop at the College of Engineering falls through, then additional costs have to be added for using a local machine shop.

#### Probability: Low

The probability of having additional support costs is low because it is not deemed necessary to need any type of additional support except from a machine shop, which is planned to be used in the College of Engineering. As long as it is scheduled to be used ahead of time there should be no problem with using the school's machine shop.

#### Consequences: Minor

If the risk were to occur there would be a minor impact on the overall performance of the project because another local machine shop could be used to construct the station's structure. The project is also well under budget so adding an additional cost for support would not be a problem.

#### Strategy

The strategy to be used to manage this risk is avoiding it by planning to use the machine shop ahead of time. The time to use it will be scheduled at least a month in advance to avoid any conflicts.

### 6.3.2 Budget Risk 2: Unexpected Component Costs

#### Description

There is the risk of having to add costs for any unexpected components. This could occur if any necessary components were forgotten on the budget list or if there is a change of design and new components need to be ordered. Also, if the quantity of any of the components are incorrect, then more components would need to be ordered.

#### Probability: Low

The probability of having costs from unexpected components is low because all components that will be needed to build the station and its subsystems were added to the budget list. Any small number of components that need to be added to the list can be added without having an impact on the budget.

#### Consequences: Minor

If the risk were to occur there would be a minor impact on the overall performance of the project because other components can be easily added to the budget list. The project is well under budget so adding any additional cost for unexpected components would not be a problem.

### Strategy

The strategy to be used to manage this risk is making sure all components needed for the project are already on the budget list, and adding any other components as soon as they are found to be necessary for the project.

### **6.3.3 Budget Risk 3: Budget Mismanagement**

#### Description

There is the risk of budget mismanagement by not correctly adding anything that needs to be purchased to the budget list and taking it out of the given budget.

#### Probability: Very Low

The probability of budget mismanagement is low because time has been taken to meet with the advisor, sponsor, and group as a whole to overview and manage the budget.

#### Consequences: Minor

If the risk were to occur there would be a minor impact on the overall performance of the project because the overall project budget is well under the given budget by the sponsor.

#### Strategy

The strategy to be used to manage this risk is keeping an itemized list to keep record and periodically checking it on a weekly basis to ensure that past purchases are taken into account for future ones.

## **6.4 Summary of Risk Status**

Many potential risks including technical, schedule, and budget risks have been identified for the project, but they are all well understood. There is a set strategy to handle all of these risks if they pose a problem for completing the project. All of the proposed risks are ready to be managed by the group through proper planning.

# **7 Conclusion**

Through the course of the semester, the E-Bike Charging and Docking Station group have had the opportunity to make an exceeding amount of headway towards the project at hand. The past two milestones were brought into account for two important goals. After analyzing the needs and requirements of the sponsor, the design team was able to have preliminary ideas of how the system would set up, how it would function, and if it was feasible at the expense of time and money. The most headway took place in the meetings with the

sponsors, as they made small tweaks and suggestions to how our proposed designs could better fit the needs of the client. The outcome of the process was several designs, both good and bad. The process of it all really showed the effort the group had collaborated on, whether that being a manual latch locking system or motorized bar gripper. The different technical scenarios and possibilities were endless to the point it was overbearing how many different ways to invent a wheel. The second milestone somewhat centralized a lot of what had been discussed and tested in theory, thus proposing a design the team thought might be a possible success. The point came to fully analyzing the system as a whole by separating it into subsystems and components done in this milestone report. The design groundwork has been laid out for the team and looks more than promising to deliver a fully-functional, innovative and aesthetically pleasing work of art. The progress of the team is turning from linear to exponential due to the genuine interest and inspiration the entire team brings together.

## 8 References

- [1] Mornhinweg, Manfred. "Transformers and Coils." *Homo Ludens*. N.p., n.d. Web. 14 Nov. 2014. <<http://ludens.cl/Electron/Magnet.html>>.
- [2] [http://msis.jsc.nasa.gov/sections/section04.htm#\\_4.9\\_STRENGTH](http://msis.jsc.nasa.gov/sections/section04.htm#_4.9_STRENGTH)
- [3] <http://www.galvanizeit.org/design-and-fabrication/fabrication-considerations/bending>
- [4] Pellitteri, F., V. Boscaino, A. O. Di Tommaso, R. Miceli, and G. Capponi. "Wireless Battery Charging: E-bike Application." (n.d.): n. pag. Web.
- [5]<http://www.pololu.com/blog/277/new-nema-17-stepper-motor-with-optional-integrated-lead-screw>

# Appendices

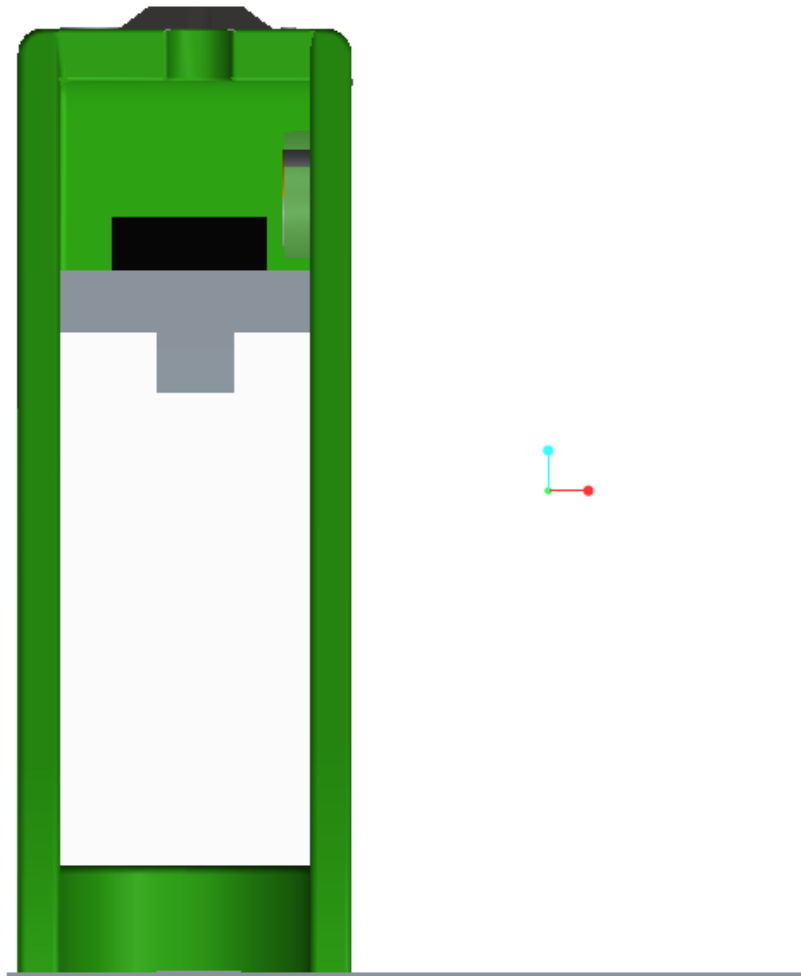

*Figure A: Front View*

Appendix B

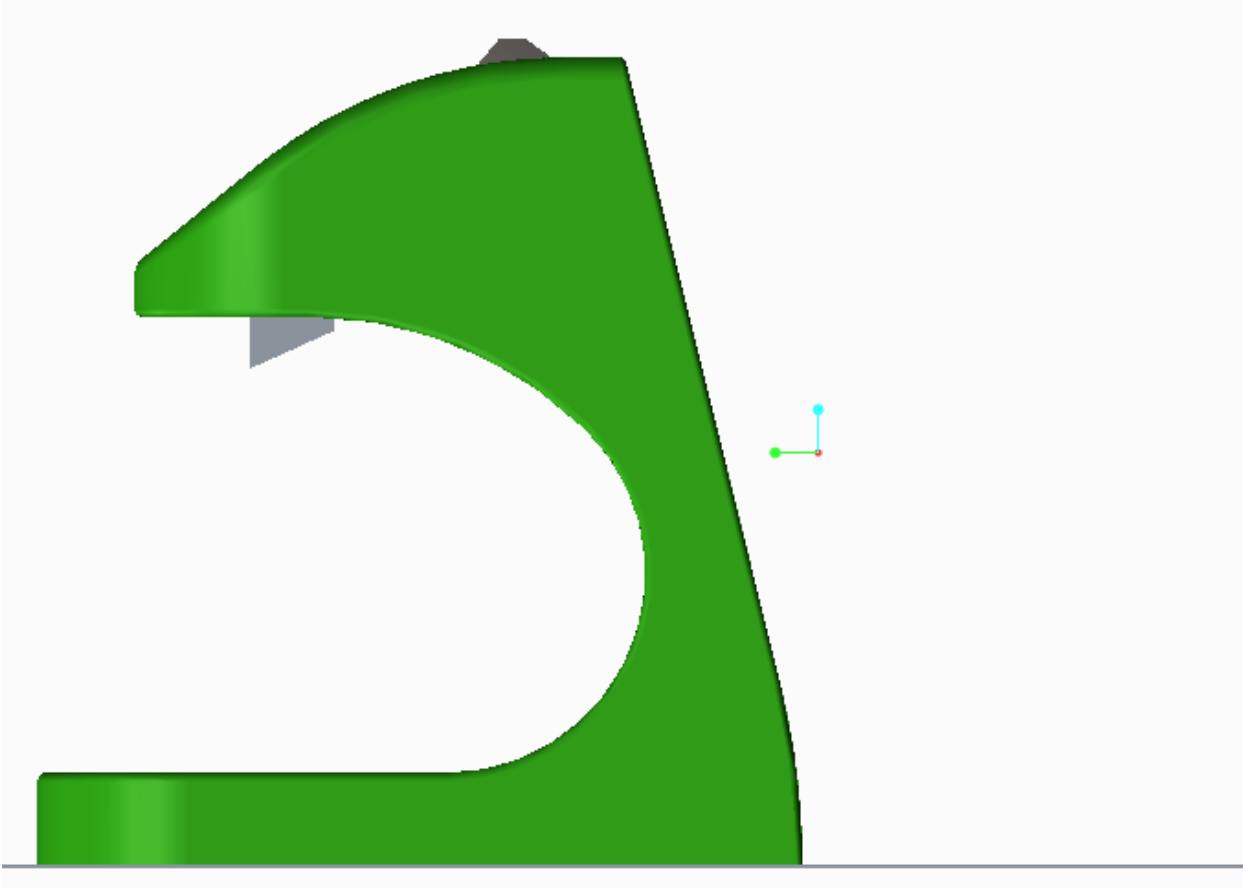
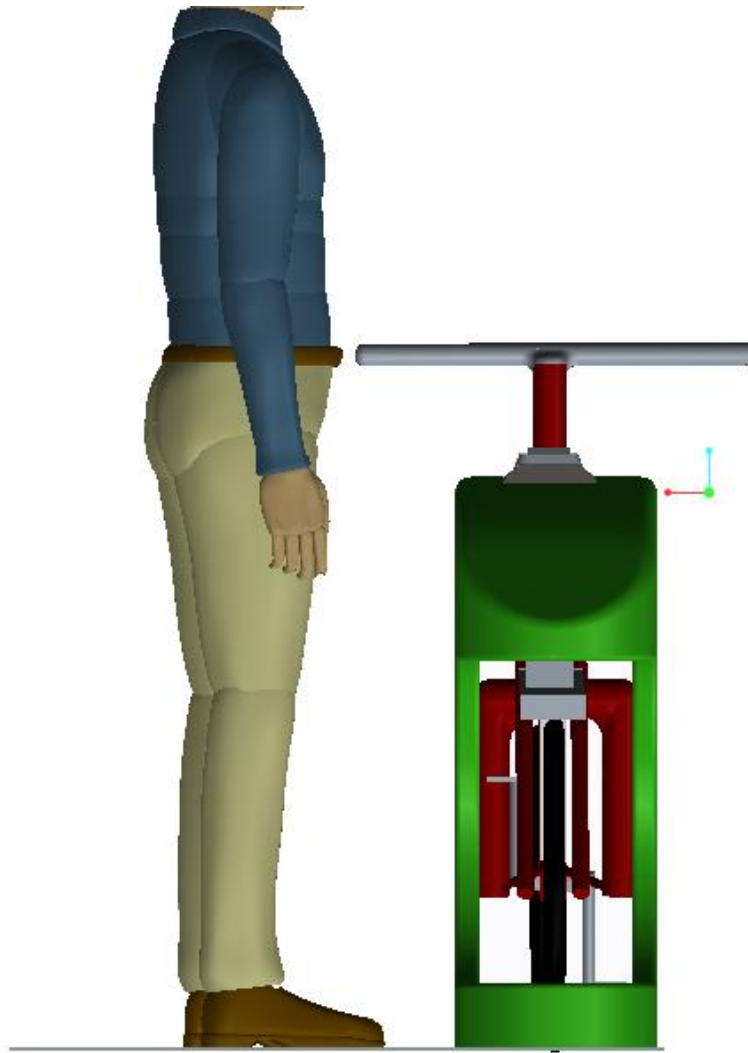

Figure B: Side View



*Figure C: Back View*