

Integrated Data Acquisition



Figure 1: Danfoss Turbocor Centrifugal Compressor

Team Number: 5

Submission Date: Friday, October 25th

Submitted To: Dr. Gupta

Authors: Luis Mendez (lm13r@my.fsu.edu), Beau Rodgers (ber13@my.fsu.edu), Keenan Cheeks (kmc11j@my.fsu.edu), Brian Roberts (bpr13b@my.fsu.edu).

Faculty Advisor: Dr. Chiang Shih

Table of Contents

Abstract	iv
Acknowledgements	v
1 Introduction	1
2 Problem Statement and Project Scope.....	2
2.1 Project Purpose.....	2
2.2 Key Technical Questions.....	2
2.3 Goal.....	3
3 Design and Analysis	4
3.1 Background Information	4
3.2 Customer Needs and Product Specifications.....	4
3.3 Methodology.....	4
3.4 Mechanical Systems.....	6
3.5 Data Analysis.....	6
3.5.1 Heat Transfer Correlations	7
3.5.2 Acquiring Known and Unknown Parameters.....	8
3.5.3 Uncertainty in Calculations	9
3.6 Sensor Selection.....	10
4 Scheduling and Resource Allocations	13
4.1 Resource Allocations.....	13
4.2 Scheduling.....	14
5 Results	16
5.1 Risk.....	16
6 Conclusion.....	17
7 References.....	18

Table of Figures

Figure 1: Danfoss Turbocor Centrifugal Compressor i
Figure 2: Simple diagram of HVAC system set up. 6
Figure 3 Gantt Chart 15

Abstract

Senior design Team 5 has been given the task of working with Turbocor on developing new systems that will assist the teams learning process and use general and specific concepts that the students will have learned in their coursework. The team's initial meeting with Turbocor dictated that the team was to work on a data analysis in order to predict failure modes of the Turbocor compressors. Bi-weekly meetings are held in which the team and their advisor, Dr. Shih, and their instructor, Dr. Gupta, discuss the merits and progress of the project. The first bi-weekly meeting proposed a testing platform to be developed instead of the data analysis. This proposal was brought to Turbocor by the team and was deemed unnecessary. The team and Turbocor discussed possible project scopes ultimately leading to our current work. The team is to design and integrate a system for determining real time efficiency of the compressor in application as a stepping stone to reach Turbocor's initial goal of predicting failure modes. The system to be integrated will consist of temperature sensors through the condenser units of existing HVAC systems and an external mass flow meter to determine the mass flow of water through the condenser unit. The integration of this system will require several steps to calculate the temperature differential from existing sensors and use collected mass flow data to determine efficiency. Once real-time efficiency can be determined accurately, the team can then use this information in conjunction with operating data to help predict failure modes for their compressors. This design was proposed to be integrated to the Variable Twin Turbo Compressor (VTT) as it is the newer system being developed by Turbocor and as such the programing in the platform is still under development.

Acknowledgements

We would like to acknowledge and thank Dr. Gupta, Dr. Shih and the many engineers at Turbocor thus far for helping to define the scope of this design project. We are grateful for Turbocor engineers that have taken time away from their projects in order to guide this design team in a productive direction and for the opportunity provided to us through both our faculty advisor and the Danfoss Turbocor company. Furthermore, we are extremely excited and thankful for Turbocor's willingness to grant the entire design team access to their on-site testing facilities and resources.

1 Introduction

Turbocor is a Tallahassee, FL based company that designs, develops, and manufactures high efficiency compressors to be used in HVAC chiller systems using innovative proprietary “mag-lev” technology. The company started in Australia in 1993 then moving to Montreal Canada in 1999. Turbocor brought their high efficiency compressors to market in 2002. Eventually being acquired by their now parent company, Danfoss in 2006, they moved to the purpose built facility in Tallahassee to cope with growing demand for their product.

Although the Turbocor compressors are known to be very reliable, to provide long-term customer satisfaction Turbocor hopes to develop methods of failure modes predictions. As emerging technologies from other companies become more and more competitive, Turbocor is turning its attention to the end users satisfaction to create a strong and loyal customer base. Turbocor is already competitive in customer service through their proactive efforts in assuring the highest manufacturing quality. However, the company desires to add another level of service through remote monitoring and diagnostics of their compressors as a means by which to increase product uniqueness and value. Many companies like General Electric and Siemens have already taken this step and integrated the necessary mechanical components into their turbines. Thus, to provide stepping stones toward achieving this end goal, our team is to use temperature sensors and a mass flow sensor to determine real time efficiency of the compressors under load.

2 Problem Statement and Project Scope

2.1 Project Purpose

The Turbocor compressors are premium products in their market. As such, it is important for Turbocor to maintain a high level of customer satisfaction. Developing technologies within their market are becoming more competitive. Due to this developing increase in competition, Tubocor wishes to add value to their product for existing and future customers through the incorporation of a method for product failure prediction.

Currently, Turbocor's compressors are only serviced post failure. Downtime is a major concern in situations where a compressor has failed. This downtime can be directly correlated to capital loss and customer dissatisfaction. For example, data centers rely heavily on their cooling systems. A compressor being down for merely a day can cause major issues to the extent of revenue loss and possible loss of assets. Another example would be a major hospital cooling system. A catastrophic failure of the compressor could potentially cause bodily harm to patients.

By designing a method to collecting real-time efficiency of the compressors, Turbocor can monitor their system and correlate a decrease in efficiency to a possible failure. By being able to predict failures, downtime of a major HVAC can be scheduled and the consumer and Turbocor can plan accordingly in order to maintain the consumer's satisfaction.

2.2 Key Technical Questions.

Key technical information is required in order to proceed with this design project. The following questions are set forth in order to assist the team in determining parameters and concepts needed to move forward:

- What concepts are necessary to aid in the determination of Efficiency?
- Based on the concepts necessary, what empirical data can the group collect from existing systems, and what other information needs to be collected?
- After the determination of missing parameters, how will these values be collected?
- Once collected, how will the signal be transmitted in a format the team can use?

- Most importantly, how will all the collected data and signals be integrated into the system, and how is this helpful in prediction of failure modes?

2.3 Goal

The design team is currently working on the collection of data that will be relevant to the determination of the efficiency of the compressor. The ultimate goal of this project is the integration of our data collection into the existing program platform of the Turbocor compressor to determine real-time efficiency in an effort to help in the prediction of compressor failure. Real-time efficiency is a vital step towards the future goal of failure modes prediction. By monitoring efficiency real-time and comparing it to collected efficiency data, the performance of the compressors can be monitored and analyzed to help determine these modes.

3 Design and Analysis

3.1 Background Information

Knowing the typical Turbocor compressor application and its basic function is essential to understanding the application of the team's project. Their compressors are typically used in commercial HVAC systems that use a chiller, cooling tower, and condenser in order to remove heat. These systems essentially run on three loops. In the first loop of the system, the Turbocor compressor circulates R34A refrigerant. The Turbocor compressors use impellers to increase the pressure and in turn the temperature of the recirculating R34A refrigerant. The heated refrigerant then runs through a chiller, which is essentially a counter flow heat exchanger, in which heat is removed by a second loop of flowing water. This cooler refrigerant then makes its way to an expansion valve which further chills the refrigerant by decompressing the gas. This chilled refrigerant then flows through the condenser. This condenser is a second heat exchanger that removes heat from flowing water in the 3rd loop and chills it. The chilled water being pumped through the 3rd loop is then used to cool air by removing heat via a final heat exchanger. The importance of this information will become evident in subsequent sections.

3.2 Customer Needs and Product Specifications

Turbocor has required a compact system that will measure the real-time efficiency of their compressor within 1% error. The specifications or constraints given to the team include; any mass flow sensing device must be external and not interfere with flow, the temperature differential and mass flow are to be measured at the condenser in an HVAC system, the sensor signals must use common language to communicate with current platforms, the efficiency calculations should maintain at error less than or equal to 1%.

3.3 Methodology

In order for the team to achieve the goal of reading real time efficiency to aid in failure mode predictions, several key tasks must be addressed.

First, the team must research and determine the valuable parameters needed in the determination of compressor efficiency. Research shows that in order to calculate the efficiency, values for the work the compressor outputs and the draw of power by the compressor are necessary. Per Turbocor, the compressor's power draw can be currently monitored by existing systems. However, the output work of a compressor in application can only be estimated based on data from product testing at the Turbocor facility. Because of this, the team must identify a method to calculating the work output by the compressor.

Using previous experience, the team determined that the work output of the compressor would correlate directly to heat transfer at various stages of the system. The team members sought out the assistance of a FAMU & FSU College of Engineering faculty member that is versed in heat transfer Dr. Vansciver. This meeting determined that values for heat transfer for the compressor loop and the condenser loop would be necessary. In order to determine said values, the mass flow rate through the compressor loop must be determined and used in conjunction with a temperature differential between the input and output of the compressor. However, determining mass flow proved to be a difficult task in application due to the phase of the fluid in this loop. The team decided to determine mass flow through the condenser loop as it is simpler because the fluid through it is in liquid form.

Investigation into HVAC systems revealed that there are no existing measuring devices for the mass flow through any point in the system. Thus, the team must select un-intrusive sensors to determine mass flow through the condenser.

Next, the temperature differential is needed through the condenser. Sensors already exist on the inlet and outlet sides of the condenser. The team has decided to collect this data from existing sensors and use it to determine the temperature differential.

An additional desired feature for the system is that it be compact in footprint. To achieve this, the team will design a mounting system to keep all components of selected sensors condensed.

The Final step in the project will be to analyze collected data and use the concepts and correlations described a subsequent section, to work in conjunction with CS Engineers in order to integrate the data into existing platforms. The data collected must determine an accurate value for real-time efficiency of the Turbocor compressor so that it may aid in the prediction of failure modes.

3.4 Mechanical Systems

The mechanical systems in the design project are limited to the mass flow sensors and their mounting bracket. Research on external mass flow sensors shows that the actual sensors are mounted separately from the control/data module supplied with them. Sensors are mounted directly to the piping and cables are run to the wall mounted control/data modules. In order to maintain a compact footprint, the team has decided to either modify or design a new mount for the sensor to be selected. This mount will keep the control unit mounted at the pipe where the sensors are to be mounted in order to avoid having to run excessive wiring and thus maintaining a compact footprint when installed in existing systems.

3.5 Data Analysis

In order to determine efficiency of the Turbocor compressor, data needs to be collected at other locations in the HVAC system. Determining the heat transfer at the condenser, will allow the calculation of other parameters needed.

The condenser is the heat exchanger of interest for this project which cools water using R134-a refrigerant by means of counter flow heat transfer. Figure (1) shows how the basic HVAC system is set up. The task given for this project is to find the efficiency of the compressor without creating an inline or intrusive design. Finding the efficiency will require two main processes. First, the heat transfer correlations must be made to link the properties of the water and the refrigerant. Second, the unknown parameters of the correlations must be accounted for with onboard compressor sensors and added sensors if necessary.

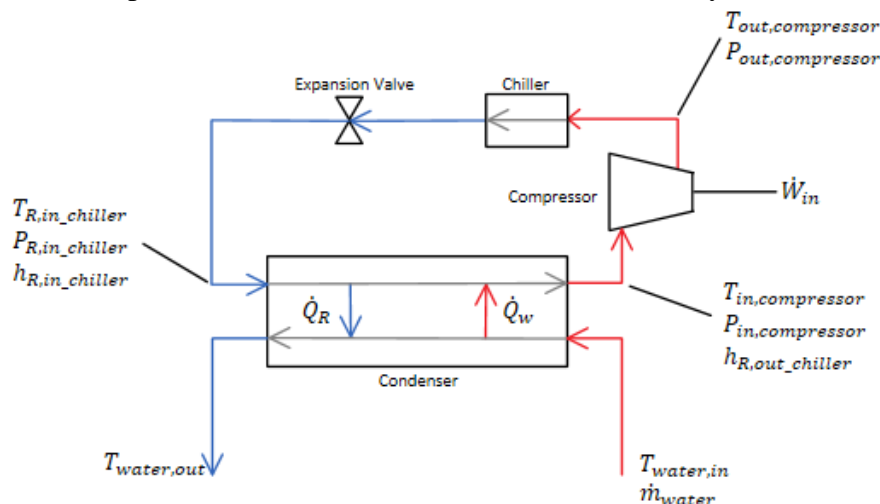

Figure 2: Simple diagram of HVAC system set up.

3.5.1 Heat Transfer Correlations

Heat exchanger calculations require a value for the heat transfer rate, \dot{Q} , which can be calculated from the known flow rate of one of the fluids, its heat capacity, and the temperature change at the inlet and exit of the condenser. We have decided to evaluate \dot{Q} of the water because it eliminates the difficulties of dealing with the gas state of the R134-a refrigerant. Equation (1) will be used to determine the rate of heat exchange the water experiences through the condenser.

$$\dot{Q}_w = \dot{m}_{water} c_{p,w} (T_{w,in} - T_{w,out}) \quad [\text{kW}] \quad \text{Eq.1}$$

Where \dot{m}_w the mass flow rate of the water, $c_{p,w}$ is the heat capacity of the water, and $T_{w,in}$ and $T_{w,out}$ are the inlet and exit temperatures of the water in the condenser. After determining the heat transfer rate of the water the mass flow rate of the refrigerant can be found using equation (2) and noting that the amount of heat transferred to the refrigerant is equal to the amount of heat taken from the water.

$$\dot{Q}_R = \dot{m}_R (h_{R,in_chiller} - h_{R,out_chiller}) \quad [\text{kW}] \quad \text{Eq.2}$$

Where \dot{Q}_R is the heat transfer rate of the refrigerant, \dot{m}_R is the mass flow rate of the refrigerant, and $h_{R,in_chiller}$ and $h_{R,out_chiller}$ are the enthalpies at the inlet and exit of the condenser with respect to the refrigerant cycle. After equating equations (1) and (2) the mass flow rate of the refrigerant can be used to find the volumetric flow rate given by equation (3).

$$\dot{V}_R = \frac{\dot{m}_R}{\rho_R} \quad [\text{m}^3/\text{s}] \quad \text{Eq.3}$$

Finally, this can be used to calculate the rate of work being produced by the compressor using equation (4).

$$\dot{W}_{out,comp} = (P_{in,compressor} - P_{out,compressor}) \dot{V}_R \quad [\text{kW}] \quad \text{Eq.4}$$

Where $P_{in,compressor}$ is the pressure of the refrigerant at the inlet of the compressor and $P_{out,compressor}$ is the pressure of the refrigerant at the exit of the compressor. After determining the rate of work produced by the compressor the efficiency can then be found with the final correlation given by equation (5).

$$\eta = \frac{W_{out,comp}}{W_{in,comp}} * 100 \quad [\%] \quad \text{Eq.5}$$

Where $W_{in,comp}$ is the amount of power the compressor draws during operation. The next step in this analysis is to determine what parameters are readily available, which parameters need to be found, and how to find them.

3.5.2 Acquiring Known and Unknown Parameters

Some of the parameters, used in the correlations laid out in section 1, are currently available without modifications to the Turbocor compressor system, however, other parameters need to be accounted for by external sensors. From equation (1) the only known parameter will be the heat capacity of water which is a thermodynamic property of water that can be looked up in a heat capacity table. The mass flow rate of the water, \dot{m}_w , will be determined using an ultrasonic mass flow rate sensor that is externally mounted onto the water pipe. This sensor will provide the flow velocity of the fluid and knowing the diameter of the pipe will ultimately give us the mass flow rate via equation (6).

$$\dot{m}_w = \rho_w V_w A_c \quad [\text{kg/s}] \quad \text{Eq.6}$$

Where ρ_w is the density of the water, V_w is the flow velocity of the water given by the ultrasonic sensor, and A_c is the cross sectional area of the pipe found using the known diameter. Next, the water temperatures at the inlet and exit of the condenser will also need to be found using an external temperature sensor. Then, from equation (2) the known parameters will be the enthalpy at the exit of the condenser due to the onboard temperature and pressure sensor at the

inlet of the compressor and the rate of heat exchange which will be found from equation (1). The only parameter that will need to be found using an external temperature sensor is the inlet temperature of the refrigerant to the condenser. This will allow the mass flow rate of the refrigerant to be calculated. Moving on to equation (4) the pressures at both the inlet and exit of the compressor are known because of the onboard pressure and temperature sensors. Also, the volumetric flow rate will be known from equation (3). Finally, from equation (5) we will be able to find the efficiency of the compressor with the known amount of power drawn by the compressor and the calculated power output of the compressor calculated by equation (4).

3.5.3 Uncertainty in Calculations

At this point in the real time efficiency via mass flow integration project both mass flow rate and temperature sensors are being researched and purchased. Thus, there aren't any experimental results to date. Once the sensors and proper supporting electronics arrive they will be installed and start pulling data as soon as possible. The theoretical uncertainties of the correlations previously discussed as well as possible risk that could arise follow.

The uncertainties of this project lay directly in the measurement tools being purchased for the measurement of mass flow rate, temperatures, and pressures at various locations of the HVAC system. To begin, the uncertainty in the mass flow rate of the water will be shown. The uncertainty here stems from the ultrasonic mass flow rate sensor which simply measures the velocity of the fluid flow through the pipe. The uncertainty in the mass flow rate is given by equation (7).

$$\delta \dot{m}_w^2 = \left[\frac{\partial \dot{m}_w}{\partial \rho_w} \delta \rho_w \right]^2 + \left[\frac{\partial \dot{m}_w}{\partial V_w} \delta V_w \right]^2 + \left[\frac{\partial \dot{m}_w}{\partial A_c} \delta A_c \right]^2 \quad \text{Eq.7}$$

Where \dot{m}_w , $\delta \rho_w$, δV_w , and δA_c are the uncertainties in water mass flow rate, density, velocity, and cross sectional area respectively. $\frac{\partial \dot{m}_w}{\partial \rho_w}$, $\frac{\partial \dot{m}_w}{\partial V_w}$, and $\frac{\partial \dot{m}_w}{\partial A_c}$ are the partial derivatives of water mass flow rate with respect to each parameter. This equation reduces further after simplification to equation (8).

$$\delta \dot{m}_w^2 = [\rho_w A_c \delta V_w]^2 \quad \text{Eq. 8}$$

The next major uncertainty that will be introduced into the calculations will be in the mass flow rate of the refrigerant shown in equation (9).

$$\dot{m}_R = \frac{m_{water} c_{p,w} (T_{w,in} - T_{w,out})}{(h_{R,in_chiller} - h_{R,out_chiller})} \quad [\text{kg/s}] \quad \text{Eq.9}$$

Where $c_{p,w}$, $T_{w,in}$, and $T_{w,out}$ are the specific heat capacity and temperature at the inlet and exit of the condenser respectively. $h_{R,in_chiller}$ and $h_{R,out_chiller}$ are the enthalpies of refrigerant at the inlet and exit of the condenser. For equation (9) the uncertainty comes from propagation of the error in m_{water} , and the uncertainties in the temperature and pressure sensors. Equation (10) gives the error in this correlation.

$$\begin{aligned} \delta \dot{m}_R^2 = & \left[\frac{\partial \dot{m}_R}{\partial m_{water}} \delta \dot{m}_w \right]^2 + \left[\frac{\partial \dot{m}_R}{\partial c_{p,w}} \delta c_{p,w} \right]^2 + \left[\frac{\partial \dot{m}_R}{\partial T_{w,in}} \delta T_{w,in} \right]^2 + \left[\frac{\partial \dot{m}_R}{\partial T_{w,out}} \delta T_{w,out} \right]^2 + \\ & \left[\frac{\partial \dot{m}_R}{\partial h_{R,in_chiller}} \delta h_{R,in_chiller} \right]^2 + \left[\frac{\partial \dot{m}_R}{\partial h_{R,out_chiller}} \delta h_{R,out_chiller} \right]^2 \end{aligned} \quad \text{Eq.10}$$

Where $\delta \dot{m}_R^2$, $\delta \dot{m}_w$, $\delta c_{p,w}$, $\delta T_{w,in}$, $\delta T_{w,out}$, $\delta h_{R,in_chiller}$, and $\delta h_{R,out_chiller}$ are the uncertainties in mass flow rate of refrigerant, mass flow rate of water, specific heat capacity of water, temperature of water into the condenser, temperature of water out of the condenser, enthalpy of refrigerant into the condenser and enthalpy of the refrigerant out of the condenser. Noting that the error due to the enthalpies of refrigerant in and out of the condenser stem from the interpolation process of temperature and pressure tables it is seen that their error like the temperature of water in and out of the condenser also comes from the accuracy of the temperature and pressure sensors available. Finally, the uncertainty in the work out of the compressor is purely based on error propagation of all the sensors and previous calculations.

3.6 Sensor Selection

Based upon the criteria identified through research and discussion with the sponsor, various brands and models were compared in order to determine the best option for this

application. A selection matrix was constructed by assigning a weight from 1-5 for each criteria and then rating them for each system with a scale of 0-3 where 0 indicates that the criteria is not met at all. The models were then given an overall rating that was the sum of each individual rating multiplied by the weight of the corresponding attribute.

The most important criteria identified was the accuracy of the measurement. Any deviation in the mass flow measurement will propagate through the rest of the calculations as shown previously. If this value is not within the acceptable range the rest of the features of the system are irrelevant.

Next in importance were three criteria involving the physical nature of the system itself. It is imperative that the sensors be able to operate over a variety of different diameter pipes. Depending on the volumetric flow and environment the chillers are operating in there could be several different pipe configurations. In addition we know that the cooling water will be fluid but not the precise temperature as this varies, an operating range from 0°C to 100°C is preferable. The third property is the range of measurable fluid velocities. This can vary widely based upon the diameter of the pipe and the necessary flow rates. A wider range was considered better. Some systems are bidirectional and report velocities as positive or negative based upon the orientation of the system. The chillers only operate in one direction so this feature is irrelevant for our purposes.

Cost was considered of moderate importance. Staying within the budget is of course mandatory, but other than the sensors themselves there is little of large value that must be acquired for this project. Most of the other components can be fabricated either at Turbocor or through the Engineering school itself at minimal cost.

Some systems include the feature to calculate heat transfer in the system. They require temperature sensors to be mounted in the flow and fed back to the control box of the flow meter. This is imperative at some point for our final goal and temperature sensors have to be integrated into the design regardless. This feature could prove helpful for the final goal of calculating efficiency and facilitate a less complex interaction between the mass flow sensor and the compressor control board by reducing the number of inputs necessary to get the desired information.

The last criteria considered was the type of outputs. It is important that the system have an output that can be read by the compressor control board and not just a display that can only be

read manually. Variety of outputs available was considered a bonus because it would keep options open when attempting to process the signal.

Table 1 Selection Matrix

Characteristics Weighted 1-5	Accuracy	Cost	Pipe \varnothing (m)	Fluid Temp($^{\circ}$ C)	Fluid Velocity(m/s)	Calculate \dot{Q} ?	Output (Analog or Digital)	Total
	5	3	4	4	4	3	2	
	Actual Values rated from 0-3							
<i>Sierra InnovaSonic 210i</i>	$\pm 0.5\%$	\$3,170	0.15 to 6	-40 to 80	0.05 to 12	No	A	46
	3	1	3	2	1	0	2	
<i>Dalian Hipeak TDS-100F</i>	$> \pm 1\%$	\$500-700	0.15 to 7	0 to 90	-30 to 30	Yes	A/D	66
	2	3	3	2	3	3	3	
<i>GE Panametrics PT878</i>	$\pm 1\%$	\$10,035	.13 to 7.6	-10 to 50	-40 to 40	No	A/D	39
	1	0	3	1	3	0	3	
<i>Greyline TTFM 1.0</i>	$\pm 1\%$	\$2,600	0.12 to 1.2	-40 to 150	0.02 to 12	No	A	43
	1	2	2	3	2	0	2	

Many systems were looked at and rejected out of hand as unacceptable for one reason or another. After 4 were settled on for further analysis the preceding matrix was compiled. It was decided that the Dalian Hipeak TDS-100F would be the best choice. It operates within all of our specified ranges and has a cost that is significantly better than any comparable systems. In addition it has the capability of calculating \dot{Q} which can then be directly output to the system. Also it has a large variety of output types which will make processing the data easier.

4 Scheduling and Resource Allocations

4.1 Resource Allocations

Team members have each contributed equally to the design process and project based on skillset. Luis Mendez is the project lead and divides tasks according to approaching deadlines from the Gantt chart, as well as assembles deliverables. Keenan Cheeks is the Lead ME and has led research on thermodynamic theories and calculation. Brian Roberts is the Administrative Assistant and has paired with the Financial Advisor, Beau Rodgers, to lead research on the mass flow sensor and temperature sensor components necessary to achieve the desired goal of compressor efficiency. The table below is a breakdown of recent and upcoming tasks and their time allotted.

Table 2 Resource Allocation

Task	Team member	Time Allotted
Website Design	Brian Roberts	4 days
Temperature Sensor Research	Beau Rodgers	1 week
Mass Flow Sensor Research	Brian Roberts	1 week
Meet with Heath Whiddon to go over Chiller configuration	Beau Rodgers	1 day
Meet with Dr. Van Sciver to go over heat transfer calculations	Luis Mendez & Keenan Cheeks	1 day
Midterm Presentation slides	Luis Mendez & Beau Rodgers	2 days
Make visuals for Midterm Report 1	Keenan Cheeks	1 day
Assemble Midterm Report 1	Luis Mendez & Keenan Cheeks	5 days
Propose and Order parts	Beau Rodgers	1 day
Final Design Presentation	Keenan Cheeks & Brian Roberts	3 days
Final Design Report	Beau Rodgers & Brian	5 days

	Roberts	
Interface bracket CAD design	Luis Mendez	5 days
Final Updated Website design	Brian Roberts	2 days

4.2 Scheduling

The previously reported Gantt chart was used to pace the project up until this point. There was an extended exploration phase where various project ideas were discussed with the sponsors and Turbocor and our project advisor, Dr Shih. Several iterations occurred before the final design goals were settled upon. After that there was a research phase where different types mass flow sensors were analyzed for their potential usefulness. Ultimately the ultrasonic technology was decided upon and different models were compared as previously discussed.

Moving forward from this point we will begin our main design phase. This has been broken up into a couple of specific tasks. The updated Gantt chart on the next page reflects these changes.

The primary tasks to begin this phase involve acquiring materials. The finalized plan of required supplies must be compiled and then ordered. The parts will take time to arrive. During this phase it will be possible to begin the design of the bracket that will hold everything in place. The dimensions of the various components are known from the documentation available online. This will enable accurate drawings to be created.

When the sensors come in it will be time to collect experimental data and determine the required steps for acquiring a useable signal. This phase will be conducted in two parts, first determining the raw signal and then designing the condition process. While a portion of the team is dealing with the sensor signal, the rest of the team will be working on a prototype of the bracket to ensure that everything fits correctly. Once a satisfactory design is finalized it will be sent to the sponsor for their approval.

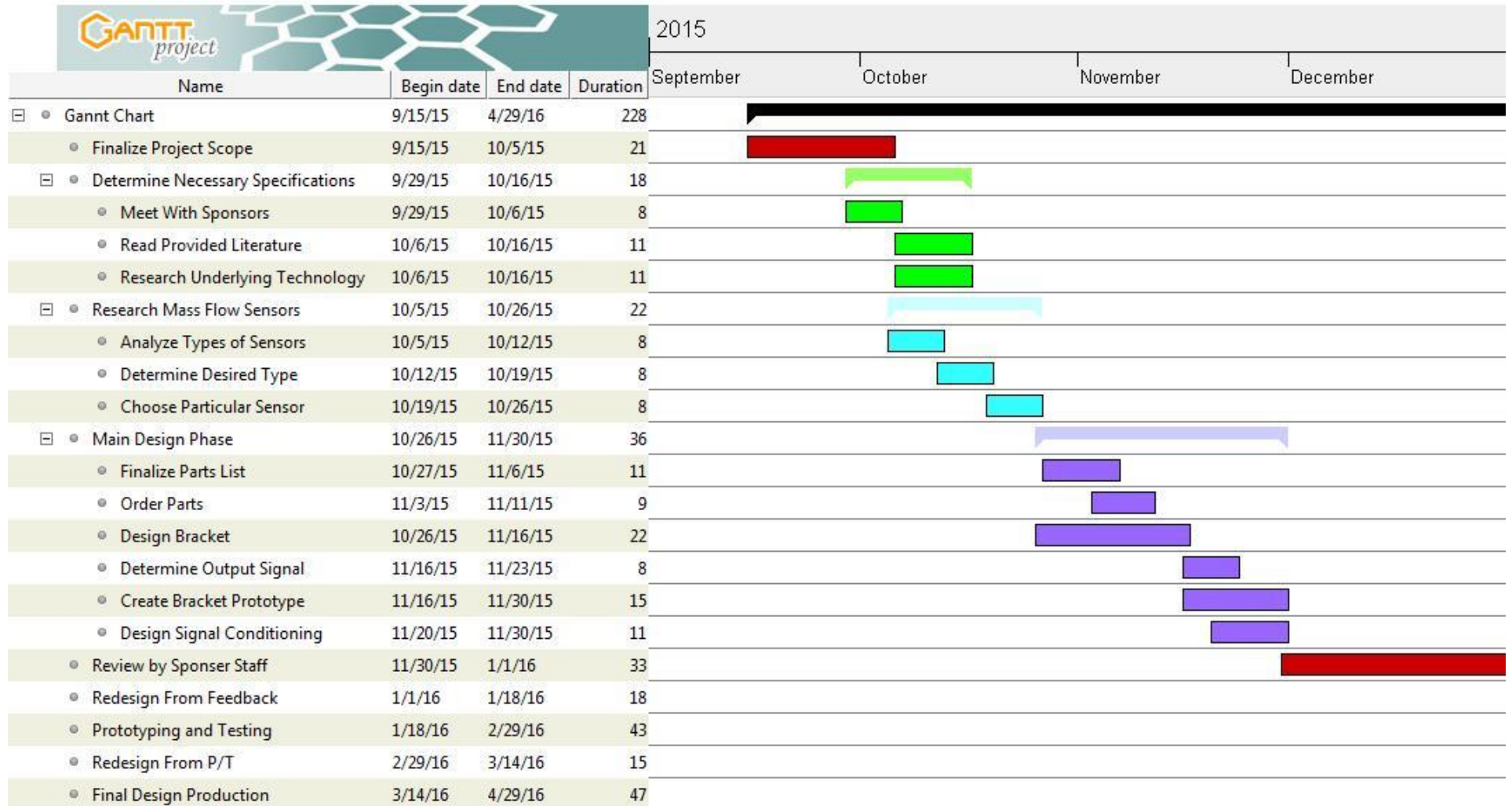

Figure 3 Gantt Chart

5 Results

5.1 Risk

While engaging in senior design projects all team members should be mindful of their surroundings and always take safety precautions when working with machinery. The team has developed a list of possible hazards that could be encountered while completing the project as well as precautions in case of such an event.

A mounting system for the interface of the mass flow sensor device is proposed as a part that must be made in the machine shop. When working with an end mill or cutting device safety glasses must be worn at all times. It is also necessary to remove all jewelry, wearing long pants and closed toe shoes. Possible dangers that could arise while end milling include workpiece dislodgement, bit binding, or possible cuts from metal chips being produced. A dislodged workpiece could be sent flying and could be a source of serious injury. Bit binding could possibly cause machine damage.

In future testing and configuration of the proposed mass flow system the team will be working at the Turbocor facility as well. It is necessary to follow all policies that Turbocor has in place as well as be familiar with the facility in case an accident arises. Turbocor requires long pants, safety glasses and safety toe shoes when entering their testing and manufacturing facility. Knowledge of where the nearest emergency exits and fire extinguishers are necessary as well.

The team has devised a list of steps necessary in the event an accident arises. First aid should be administered immediately in case of a minor cut or burn. In the case of fluid entering the eyes they should immediately be flushed with water. The team advisor Dr. Shih and the professor Dr. Gupta should then be notified of the event. The shop manager should then be notified as well as the head of the mechanical engineering department. In the case of a serious injury, emergency medical services should be contacted.

6 Conclusion

Turbocor seeks a real time efficiency readout to monitor equipment health in the first step to determining future failure modes. Team 5 has proposed a plan to incorporate a non-intrusive mass flow clamp on device coupled with sensors in pre-existing ports to accomplish this task. Thermodynamic laws and algorithms will transform this data into a usable form for Turbocor that will add value to their product as well as their customer. The team seeks to get approval and order the necessary equipment in the following weeks to stay on schedule. Effectively executing project plans are of importance but safety of all team members are held to the highest regard. It is necessary to follow all protocols while working in the machine shop as well as the Turbocor facility. In case of an incident the proper personnel should be notified immediately

7 References

- Danfoss. n.d. 24 9 2015. <<http://industrialrefrigeration.danfoss.com/assets/0/114/137/138/17179871081/17179873132/42913673-264d-4750-8c9b-484debe90f4f.jpg?n=1124>>.
- Lomas, Charles G. *Fundamentals of Hot Wire Anemometry*. Cambridgeshire: Cambridge University Press, 1985.
- Power Generation*. n.d. 24 9 2015. <<https://powergen.gepower.com/service-optimize/services/gas-turbines/software-analytics/monitoring-and-diagnostics.html>>.