

Midterm Report: Concept Generation and Selection



Design and Development of an Automated Continuous Harvesting System for Microalgae Photobioreactors

Team Number: Group 9, FIPSE: UFPR - FSU Senior Design

Submission Date: October 9, 2015

Submitted To: Dr. Nikhil Gupta

Sponsor: Dr. Juan Ordonez

Authors: Kaelyn Badura (ksb12)^α, Ben Bazylar (bjb12e)^β, Courtnie Garko (cmg11k)^β, Benalle

Lemos^α, Yuri Lopes (yml12)^β, Tomas Solano (ts11h)^α

^α – Department of Mechanical Engineering, UFPR – Universidade Federal do Paraná

^β – Department of Mechanical Engineering, FSU – Florida State University

CONTENTS PAGE

Table of Contents	Page
I. Problem Statement.....	1
1. Background Information.....	1
2. Current State of Relevant Technologies.....	2
II. Project Scope.....	3
1. Key Technical Considerations.....	3
2. Goal Statement.....	3
3. Project Objectives.....	4
4. Project Constraints.....	4
III. Product Specifications.....	5
1. Design Specification.....	5
2. Performance Specifications.....	5
IV. Methodology and Design Approach.....	6
1. Literature Review and Design.....	6
2. Testing and Validation.....	7
3. Construction and Implementation.....	8
V. Concept Generation and Selection.....	9
1. Cultivation Initiative.....	9
2. Harvesting Initiative.....	11
VI. Logistics.....	13
1. Challenge Identification	13
2. Risk Assessment.....	14
3. Schedule and Resource Allocation.....	14
VII. Conclusion.....	15
VIII. Acknowledgements.....	16
IX. References.....	17
X. Appendices.....	18

Table of Figures	Page
1. House of Quality.....	6
2. Morphological Chart - Cultivation.....	9
3. Decision Matrix - Cultivation.....	9
4. Option 2 selected for design component - Cultivation.....	10
5. Morphological Chart – Harvesting.....	11
6. Decision Matrix –Harvesting.....	12
7. Option 1 selected for design component – Harvesting.....	13
8. Gantt Chart.....	15

Table of Tables	Page
1. Tanfloc Sedimentation Test.....	7
2. Chitosan Sedimentation Test.....	7

I. Problem Statement

As a result of waning fossil fuel resources it is desirable to have access to a sustainable alternative energy source. Microalgae photobioreactors are viable options for simple and sustainable energy source production. The operation of these bioreactors has the potential for automation and produces environmentally friendly biomass and biogas which have many widespread applications, as aforementioned. The current state of microalgae photobioreactors is very dependent on consistent maintenance and check-ups to keep the algae growing. In addition, there are no viable methods for automated harvesting of the microalgae. This is unsatisfactory because it limits the scope of utilizing microalgae as a large scale biofuel source. UFPR in conjunction with FSU are sponsoring the Senior Design team to develop a continuous harvesting system which requires minimal intervention as a solution to the harvesting problem.

1. Background Information

“Technology for producing and using biodiesel has been known for more than 50 years”¹ Research in potential biodiesels such as soybeans, animal fats, and vegetable oils have opened a large field of study into alternative natural fuel sources and mass production of these renewable resources^{1,2}. Microalgae have emerged as a highly sought alternative fuel and point of biodiesel production due to their high growth rate, use of available natural resources such as solar radiation and CO₂, and can be produced using a minimal amount of non-arable land. This is extremely important as it indicates the potential for usable microalgae to be produced efficiently all while not impacting the agricultural capacity of a location. Additionally, microalgae are resilient and tolerate a relatively wide range of growth conditions. One observation which follows from the versatility of the microalgae is the potential to cultivate algae in reclaimed agriculture or municipal water.² This has led to the conclusion that microalgae is not only a potential biofuel resource, but that it can become a method to recycle and clarify used water. Additionally, produced biomass can also be utilized as a food stock, as a source for dyes, medical applications, and more.²

For many years, FSU-FAMU College of Engineering has partnered with the Federal University of Paraná’s Center for Research and Development of Self-Sustainable Energy (NPDEAS). NPDEAS is a research lab in Curitiba, Brazil that focuses on the growth, enhancement, production, and application of microalgae, a product that can be used as an alternative fuel source. Recently, research in both facilities has been done to try and optimize the growth of algae in an attempt to discover the most efficient environment and process of cultivating the biomass. Previous FSU- FAMU Senior Design groups along with the help of Dr. Juan Ordonez have spent many hours researching the most effective levels of CO₂, the proper angle of flasks set for maximum algal growth, peak points in growth, time required in the photobioreactor and many smaller aspects that contribute to efficient biomass production. Both small and large scale harvesting plants have been designed and are currently in use to cultivate microalgae around the world. All previous research and microalgae system developments have been batch, semicontinuous, partially or non-autonomous until now and no groups have attempted to design an continuous and fully automated system that will increase production, maximize time efficiency, and lessen the need for human interference to keep the biomass production running.

Further research done by engineers such as Yusuf Chisti¹, Sina Salim, and many others has helped to contribute to knowledge on cultivation, flocculation, harvesting microalgae,

photobioreactor engineering, and the potential uses of microalgal biomass. Their published works including “*Biodiesel from Microalgae*”¹, “*Flocculation as a low-cost method for harvesting microalgae for bulk biomass production*”², and other similar papers have helped to better the understanding of the entire process and the future economical improvements that can be made by using microalgae biomass in place of diesel fuels.

2. Current State of Relevant Technologies

Currently, there are few gaps in the actual production of biomass from microalgae, nonetheless, extensive research is being performed on how to best produce and utilize microalgae. On a broad scale, growth and cultivation has been generally optimized, however, there is still an observable lack of standardization between the used cultivation setup and cultivation parameters. The most common process for the growth and harvest of microalgae consists of cultivation, flocculation, coagulation, clarification (also called sedimentation) and extraction.^{1,2,3}

Cultivation of microalgae can occur in two ways: open or closed. The most common example of open cultivation is the usage of natural bodies of water or artificial ponds. The advantages to using an open system include the usage of natural water, available sunlight, and ease and cost efficiency of installation and operation.³ However, open systems face many issues including contamination and difficulties with the control of nutrients, light, and CO₂ supply. Open systems, such as raceway ponds also require large land area adding an extra cost. Closed systems can be artificially or naturally illuminated, can be implemented inside or outside, offer more reliable culture condition control, and can be compact in order to increase space efficiency.³ One disadvantage to utilizing a closed system is that they can be more expensive and require more maintenance. Common examples of closed cultivation systems include airlifts and photobioreactors.³

Harvesting of microalgae is a multistep process which involves flocculation, coagulation, clarification, and extraction.^{2,4} Flocculation is the process by which algae cells are automatically, chemically, or otherwise modified so they will conglomerate into larger clumps of algae cells known as ‘flocs’.⁴ Flocculation also typically involves lower speed mixing, while coagulation usually entails the usage of higher speed mixing, however for some processes flocculation and coagulation can be combined as one process with a longer duration. During automatic flocculation, algal cells naturally coagulate and sediment most commonly due to changes in cultivation pH as a result of microalgal CO₂ consumption.^{4,5,6} Automatic flocculation is relatively simple and inexpensive, however it is less time efficient than other methods. Chemical flocculation relies on the addition of chemicals which are used to manually neutralize the charge on the exterior of the microalgal cells and usually uses iron, aluminum, magnesium, and calcium. Chemical flocculation is more time efficient than automatic flocculation but requires the usage of chemicals and, depending on the intended application of the produced biomass, an additional purification process to remove residual flocculant.⁴ Other methods which can also be utilized to flocculate the microalgae include filtration, centrifugation, electroflotation, and electroflocculation. Electroflocculation will be focused on as an alternative flocculation method due to its relevance to this project.

Interest in the method of biomass flocculation called electroflocculation has occurred recently. This is an electrical process by which the charge of the suspended particles are neutralized allowing them to come close enough together that they coagulate due to the Van Der Waals attraction or even form hydrogen bonds. Once the suspended particles i.e algae cells, have

coagulated, they become heavy enough to sediment. The process of electroflocculation requires two “sacrificial” anodes that will provide the ions needed to neutralize the cells. The anodes are connected to a power source and placed in the volume of culture to be flocculated. Pulses of electricity at low voltage (5V-30V) are applied causing the neutralization and therefore sedimentation.

II. Project Scope

1. Key Technical Considerations

This is a fundamentally interdisciplinary project which fuses heavily weighted mechanical engineering concepts including control volume flow and flow control with chemical engineering, and life sciences.

There are many pressing ideas, concepts, and processes which need to be considered during the development and execution of this design project. There are five main technical considerations which will direct the evolution of this project.

These five key technical considerations include:

1. Standardization of cultivation process and procedure.
2. The design of a larger than laboratory scale enclosed cultivation system which effectively demonstrates scalability of laboratory scale proof of concept.
3. Investigation and optimization of time required to harvest 1 gram of algal biomass per liter of culture.
4. Optimization of space efficiency of developed design to keep space usage to a minimum.
5. Creation of a minimal to no loss system characterized by the reuse of recycled medium.

2. Goal Statement

The goal statement specified within a project outlines the general aims of the project. For Group 9, the FIPSE: FSU – UFPR Senior design team, the goal statement is given below.

Goal Statement: “**Design of an automated and continuous harvesting system for microalgae**”

3. Project Objectives

Objectives are tangible milestones against which to gauge progress and quantify success in fulfilling the outlined goal. The relevant objectives for the design of an automated and continuous harvesting system for microalgae are defined below.

1. Biomass production process must be fully automated.
 - a. From cultivation through collection and flocculation to separation.

2. System must have ability to separate produced biomass and clarified water.
3. Must work for batch, semicontinuous, and continuous collection.
4. Must incorporate continuous flocculation and sedimentation.
5. Must be sustainable, both in construction and in process.
 - a. Minimized energy and resource consumption.
6. System must be scalable and will show functionality at both lab and pilot scales.
7. Harvesting system will work with different species of algae.

4. Project Constraints

These are requirements potential designs must meet in order to be fully considered as a legitimate and appropriate design which meets sponsor's expectations. There are eight main logistical and technical constraints outlined for the design and development of an automated and continuous harvesting system for microalgae photobioreactors.

1. The developed system must work with FSU's current skeleton photobioreactor infrastructure.
2. The total cost may not exceed \$1,500.
3. The clarified medium must be recyclable.
4. The produced biomass must remain usable (aimed towards the production of biodiesel) and should require no additional purification.
5. Harvesting process should be continuous, with the option of batch or semi-continuous operation, and requires minimal human interaction.
6. Entire laboratory scale system must be less than 10 m² and should accommodate at most, 10 L in cultivation and sedimentation chambers.
7. The entire system's flow rate will be dictated by the growth rate of the utilized microalgae. The growth rate of each algae is different and therefore the system must be able to adapt.
8. Developed system must function in various environments and be able to maintain a cultivation temperature of 16-27 °C.

III. Product Specifications

1. Design Specifications

For this project, the goal is to have two fully functioning systems of different scales. The first system will be designed for commercial and educational research purposes and will be restrained to the size of an average table, less than 10 m², for usage in simple lab settings. The laboratory, or ‘table-top’, scale of the system will serve as a proof of concept of the system functionality. The main objective of this system, aside from functional proof of concept, is to provide interested parties with a continuous and low maintenance supply of algae biomass for research and other relevant applications. This means that the biomass cannot be contaminated, should not require an additional purification process, the system should be fully automated and should require minimal maintenance. The second system will be created for quasi-industrial purposes and applications and will make use of a mini-photo bioreactor. This scaled up version of the system will serve as proof of scalability, to ultimately industrial scale photobioreactors (12,000 L). The main objective associated with the scaled up system is to provide a continuous means of biomass extraction while increasing production and efficiency as well as eliminating post-processing of the product.

Constraints have been overviewed in a previous section. These project constraints dictate the design specifications. The major considerations that are related to innovation within this system are minimizing production time, minimizing or elimination of post-processing and minimizing space usage. Additionally the required continuous regime of biomass extraction is vital to design specifications, and is discussed further in Performance Specifications.

2. Performance Specifications

The performance specifications are heavily linked to design specifications as form and function are always related. The performance of the systems (tabletop and quasi-industrial) is governed by the need for the automatic and continuous production of biomass. The system must cultivate and harvest the algae with minimal human interference and maintenance. The collection of the produced biomass must be immediate and in a manner that will avoid a short circuit to the system i.e overflow, backflow, and algal contamination of recycled medium. More specific to the large scale, quasi-industrial system is the minimization of post-processing. The final products desired is ‘fatty’ biomass for the production of biodiesel and biomass for animal feed. This signifies that if possible biomass centrifugation or the addition of chemical flocculants should be bypassed.

IV. Methodology and Design Approach

The design of an automated microalgae cultivation and harvesting system consists of three major components. These include: the control implemented for the automation of the system which is composed of the microcontroller, source code, and actuators; cultivation which consists of medium preparation and disbursement, the cultivation tank, and culture conditions such as illumination and aeration distribution; lastly is the harvesting component which is comprised of the flocculation, sedimentation, and extraction of biomass products.

1. Literature Review and Design

The design process for these subsystems began with a literature review. This review is characterized by the reading and compiling of an ample library of relevant research that aids in the design of these systems. The literature agglomeration included papers that gave insight into what problems are being faced in the industry and limitations of these systems. Through continued literature review a standard cultivation method can be developed and the creative design process started.

The creative design process consisted of breaking down the systems into the major components. Once the components were identified, research was conducted on how the components operate and how they can be substituted or omitted. Taking advantage of the six group members each member of the team presented his or her own unique ideas and designs for each component. Once the designs had been generated through the morphological method and compiled, the decision on which design was to be used, was finalized. These decisions were reached with the aid of decision (Pugh) matrices. These tools served to narrow available options to the two top designs, which were both considered and underwent in depth discussion. A house of quality, seen in figure 2, was created and helped to weight the importance of each requirement and characteristic going into the design. Sponsor requirements were identified as system must be fully automated, must separate biomass from clarified medium, must be adaptable, must be able to continuously flocculate and sediment biomass, must be scalable and should work with different types of algae. Relevant engineering characteristics were identified as volume of biomass, resistance to corrosion, energy consumption, timing and control, biomass extraction efficiency, and clarified design.

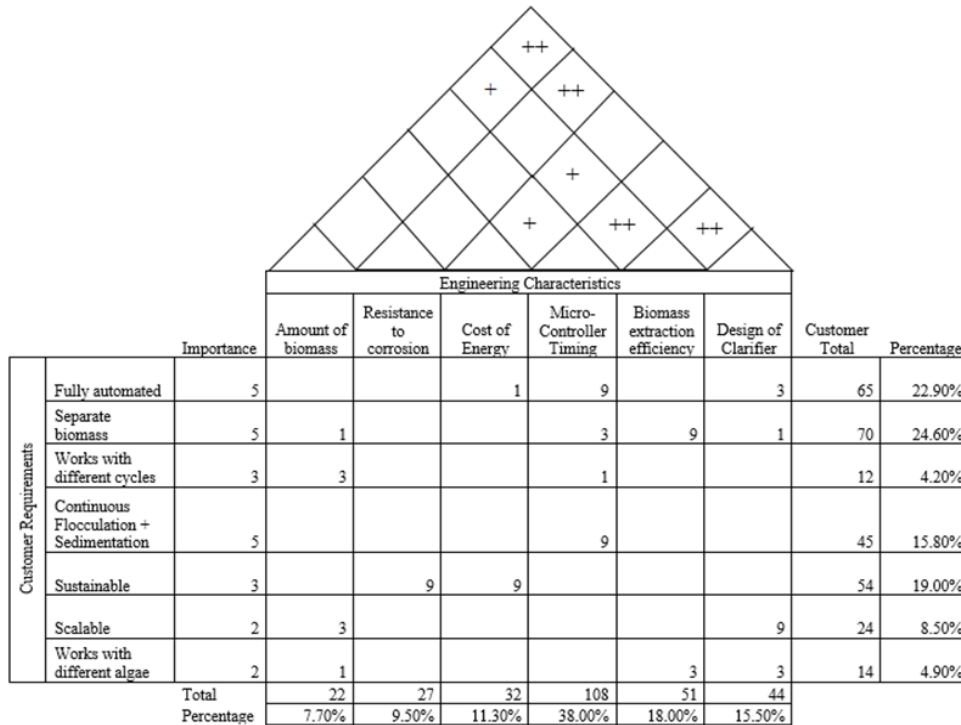

Figure 1. House of quality displaying relationships between sponsor (customer) requirements and engineering characteristics.

2. Testing and Validation

Once the design was finalized, several tests needed be done to dimensionalize the components. Although chemical flocculation is the main candidate thus far for the flocculation other methods are being considered. Sedimentation rate tests were conducted with two commonly used chemical flocculants. Tanfloc and Chitosan were tested at four different concentrations to determine clarity and flocculation (sedimentation) rates and time. All results were estimated for the sake of baseline visualization to be considered when choosing the flocculation procedure. Algal column heights were recorded every 30 seconds to 1 minute and these data points were used to find an appropriate fit. This trendline was then integrated with respect to time and divided by total experiment time in order to generate settling velocity. End clarity of the water following flocculation was recorded from 1 (clearest) - 5 (opaque or minimally clarified). Table 1 displays the results for the Tanfloc sedimentation test. Table 2 displays the results for the Chitosan sedimentation test.

Table 1. Tanfloc results from sedimentation test.

Concentration (mgL^{-1})	Settling Velocity (mms^{-1})	Water Clarity
7.5	0.1814	2.5
10	0.1665	1
12	0.1589	1

Table 2. Chitosan results from sedimentation test.

Concentration (mgL^{-1})	Settling Velocity (mms^{-1})	Water Clarity
7.5	0.2021	4
10	0.1854	2
12	0.1446	2

Note that data is only reported for concentrations of 7.5, 10, and 12 mgL^{-1} . Tests were also performed using concentrations of 5 mgL^{-1} , however, the water clarity was so poor that it impeded the collection of useful data and this concentration was therefore regarded as negligible. All collected data for for concentrations of 7.5, 10, and 12 mgL^{-1} can be seen in appendix A. The average settling velocity was approximately 0.177 mms^{-1} for Chitosan and 0.171 mms^{-1} for Tanfloc. Chitosan exhibited a higher settling velocity, but overall worse water clarity

the Tanfloc following flocculation. It is for these reasons, coupled with Chitosan's high market price that, should chemical flocculation be pursued, Tanfloc is the best option.

Other means of alternate flocculation remain to be tested for their efficiency and effect on settling rate. These results will be compared to determine which flocculation method is to be used. Once some of the parameters are known, reached through further testing, dimensionalizing of a prototype will begin. This prototype will serve as a testbed for other aspects of the system. The type of lamella structure will be determined by testing different configurations in the prototype testbed. Also extraction of biomass and the automation will be tested to ensure a seamless and continuous transition from cultivation to harvesting.

3. Construction and Implementation

Due to the nature of the project; i.e the group, as well as the equipment is split between two countries; different tasks or stages of the project will be completed by each part of the team. The team as a whole will take part in the design process for the prototype during the first semester. Once the design has been finalized, a lab scale prototype will be built in order to prove its viability and allow for testing to later be optimized. The building of this prototype will be done at UFPR by the three group members located there. While the building of the prototype is underway the FSU group members will start setting up micro algae cultivation equipment and cultivating microalgae to then run a trial inoculation of a mini photobioreactor as well as designing a "table-top" cultivation unit for final product delivery. The mini photobioreactor will be used to scale up the designs next semester (Spring 2016). Starting the 2016 Spring semester, the entire team will be in Tallahassee and the scaling up, optimization, and final system will be completed.

V. Concept Generation and Selection

Concept generation was performed through the morphological method. The morphological method allows for complex systems to be broken down into simple components that ideas are then generated for. Pugh decision matrices were used to weigh all design ideas for each component. The weight values of each category added to unity and the score given to the components was based relative to the remaining components. Using this method, the top two designs for each component were determined. The complete decision matrices for the cultivation and harvesting initiatives are shown in Appendices B.

a. Cultivation Initiative

The main components in the cultivation initiative were the sensors used to control the system, the mixing used to mixing different medium components during medium preparation, the structural design (form) of the cultivation process, and the mechanism and/or process used to transfer fluids. Figure 2, pictured below, shows a general morphological chart created to show different components options for each function within the cultivation system.









Option	Solutions		
Function			
Composition Sensors	Volume	Force	Displacement
Mixing			
Structural Design			
Transferring Fluid			

Figure 2. Generalized morphological chart for cultivation concept generation.

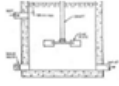
As seen in figure 2 (left to right), the types of composition sensors to be considered for system control are volumetric, force, and displacement sensors. The mechanism used to mix different medium constituents during the medium preparation could be accomplished using a static inline mixer, aeration, or a standard mixing tank with a turbine. The structural design of the cultivation part of the process can take the form of 2 liter erlenmeyer flasks, a horizontal rectangular enclosure, or a vertical rectangular enclosure. Within the cultivation process the transfer of fluids can be accomplished through the use of a mud pump, an auto-siphon, or a solenoid valve. Each of these components was scored relative to the other generated options for each function. Figure 3 shows an example of a decision matrix which was used to determine the best and second best option for the structural design within the cultivation process.

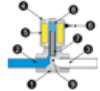

Function: Structural Design	Criteria						
	Solutions (Weight)	Cost (2)	Size (2)	Effectiveness (1)	Maintenance (2)	Implementation (3)	Total
1. Erlenmeyer Flasks 		2	6	5	8	5	26
2. Horizontal Tank 		4	12	5	16	15	52
3. Vertical Tank 		6	7	5	4	5	27
		12	14	5	8	15	54
		6	8	9	4	5	32
		12	16	9	8	15	60

Figure 3. Decision matrix for the structural design component of the cultivation process.

After different components were generated and rated different combinations of these components were assembled. These different designs were then considered relatively and individually in order to make a final design selection. Option 2 was selected based on its components and their relative merits and advantages within the cultivation process. Option 2 can be seen in figure 4.













Option 2	Solutions		
Function			
Composition Sensors	Volume	Force	Displacement 
Mixing		 	
Structural Design			 
Transferring Fluid			 

Figure 4. Option 2, selected for design development.

The components selected for the cultivation part of the system were done so based on their effectiveness, price, easiness of implementation, among other part specifications. For the sensor used to detect the amount of recycled medium returning from the clarifier, a displacement iR LED sensor was selected based since it is easy to implement and has low cost. When mixing the medium and the distilled water, a simple air pump was selected since it will be able to continuously mix the system without excessively disrupting the algae growth. Furthermore it is relatively inexpensive and has low power consumption. For the structural design, a vertical system that was selected since it will be able to maximize the use of gravity when transferring new medium and distilled water into the cultivation stage. This will minimize the use of pumps and which lowers power consumption. In order to transfer the fluid between stages we selected a solenoid valve that can be controlled with an Arduino microcontroller. This was selected based on the vertical structure design and will allow the fluid to easily move through the pipes when the valve is open.

a. Harvesting Initiative

The main components in the harvesting initiative were the mechanism used for coagulative mixing, the mechanism used for flocculation mixing, the lamella shape and configuration used in the clarification process, and the method or mechanism of biomass extraction. Figure 5, pictured below, shows a general morphological chart created to show different components options for each function within the cultivation system.











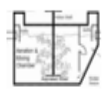
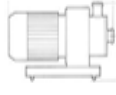

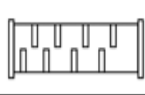

Option	Solutions				
Function					
Mix-Coagulation					-
Mix-Flocculation					-
Clarification					-
Extraction					

Figure 5. Generalized morphological chart for harvesting concept generation.

As seen in figure 5 (left to right), the types of mechanisms being considered for coagulative mixing are a static inline mixer, a aeration tank, a kinetic mechanical inline mixer, and a standard mixing tank with a turbine. For the flocculation mixing the designs considered included a static inline mixer, a bulb flow control segment, baffles, and a standard mixing tank with a turbine. The clarification function considered four different lamella designs including standard angled flat plate lamellas, conically arranged tubular lamellas, angled tubular lamellas, and angular corrugated lamellas. Extraction was going to be executed using either a mud (sludge) pump, a cam mechanism which emulates swallowing, a conveyor, an auto-siphon, and a free fall valve.

Figure 6 shows an example of a decision matrix which was used to determine the best and second best option for flocculation mixing within the harvesting process.





Function: Mixing (Flocculation)	Criteria					
Solutions (Weight)	Cost (2)	Size (1)	Power (2)	Maintenance (2)	Viability (3)	Total
1. Static Inline Mixer 	8	9	10	7	6	40
	16	9	20	14	18	77
2. Mixing Bulb 	9	8	10	8	8	43
	18	8	20	16	24	86
3. Baffles 	10	9	10	6	8	43
	20	9	20	12	24	85
4. Kinetic Mix Tank 	5	5	2	5	9	26
	10	5	4	10	27	56

Figure 6. Decision matrix for the flocculation mixing within the harvesting process.

Three different configurations for the harvesting system were created. These configurations were; all the top rated design components, all the second rated design components, and a third configuration of a mixture of top rated and second rated components. After different components were generated and rated different combinations of these components were assembled. These different designs were then considered relatively and individually in order to make a final design selection. Option 1 was selected based on its components and their relative merits and advantages within the harvesting process. Option 1 can be seen in figure 7. Additionally, a decision matrix used to validate this option as the best design choice and can be seen in appendix B as Figure B17.





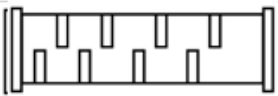
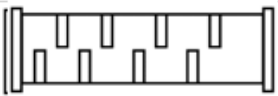
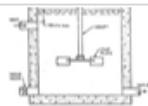
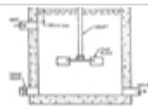





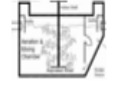

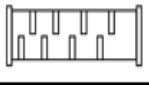

Option 1	Solutions				
Function					
Mix-Coagulation					.
Mix-Flocculation					.
Clarification					.
Extraction					

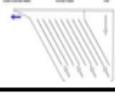
Figure 7. Option 1, selected for design development.

Figure 7 shows the chosen component designs for the harvesting process of the system. The first component is a the coagulation mixing component, this component’s aim is to quickly mix and homogenize the chemical flocculant and cultivated algae mixture. An in-line static mixer was chosen for this purpose. It is well suited for continuous applications and requires no energy input. The installation of this component is easy and can be modified quickly and with no difficulty depending on the dimensions of the system. The next component evaluated was the flocculation mixing. This component is charged with gentle mixing to form the coagulation of algae cells. A in-line bulb-like part was designed for this aspect of the process. The bulb aims to promote circular by mixing⁸, as shown in figure d1 in Appendix D, and therefore form more uniform coagulates that approach spherical shape to accelerate sedimentation in the following steps of the process. Following the flocculation process is the clarification stage. This consists of sedimentation and extraction. The sedimentation of the agglomerated cells is directly proportional to the area allotted for settling, therefore lamella structures were an obvious choice to increase the settling area. The choice to use corrugated lamella plates was made due to its optimal surface area compared to how compactly they can be placed and achieve the greatest use of clarifier tank volume. Lastly the extraction method of the biomass is to be completed by a modified peristaltic pump. This was chosen due to the anticipated high density and viscosity of the biomass sludge.

VI. Logistics

1. Challenge Identification

a. Cultivation Initiative

Potential challenges for later cultivation could include the increased level of difficulty to achieve efficient light and CO₂ distribution in larger scale systems. With smaller scale prototypes, light is able to reach all of the algae mixture as it is confined to a smaller transparent volume. More light ensures that all the algae can grow properly and efficiently to be harvested into biomass. However, with an increase in volume (larger scale models) and the same high opacity levels, light could potentially have a harder time reaching the algae in the middle of the

system. More CO₂ might be needed once the scale is increased as well. Another potential challenge in the cultivation process includes ensuring the longevity of live algal cultures. As the process will be automated and continuous, the goal is to have as little human interference as possible. The automated system must be designed to recognize when the algae-nutrient mixture is fully developed and ready to move to the cultivation stage. Moving the algae too soon would decrease the amount of biomass produced, and moving it too late would result in the loss of live algae cultures. The system must be designed with a way of detecting when the current mixture of algae has reached its peak growth. The final challenge in the cultivation process of this system could be the recycling of clarified medium. Since our group would like to reuse the water-nutrient medium again once the biomass has been extracted from it, it is important that the proper amount of nutrients are added back into the mixture so that it is strong enough to grow more algae, keeping the process continuous.

b. Harvesting Initiative

During the harvesting process of the system, many challenges upsurge. These include flow rate control, flow regime control, and extraction of solid biomass. Using the standard chemical means of flocculation the produced biomass still holds a lot of water and therefore needs to be centrifuged and dehydrated using ovens before post-processing to achieve a final oil product that will be converted to biodiesel. These added steps after flocculation and clarification have a large added monetary and energy cost to the process and trying to omit these steps will prove difficult.

2. Risk Assessment

Because accidents often result from an unexpected reaction or event, potential risks that could occur in this design project have been identified and certain procedures have been developed in the hope of preventing or mitigating these risks. The first potential hazard found could result from the breaking of materials when building the entire structure. Since the system needs to be transparent in some areas to allow light to shine through, it would be best to use a strong transparent plastic that will not break easily if dropped. Dropped materials could pose potential harm to group members with sharp pieces and the spilt water medium. The biggest potential risk that was identified in our design was the proximity of electronic controls and the algae- water mixture. To ensure that no one or equipment is harmed through shocks, tests will be run with low voltage in each design to ensure no water can reach the electronics before the prototypes and design is tested fully. The last potential risk in this project included the potential for submerged components to be corroded. To ensure that these submerged parts do not have to be replaced, it is important to select a non-corrosive material before constructing the final design. All of these measures can help to ensure that there is as little risks to equipment and group members as possible when designing, constructing, and operating the automated harvesting system. A Formal complete risk assessment can be seen in appendix E, which is included in the hard copy of the report.

3. Schedule and Resource Allocation

A gantt chart is provided below as figure 8 and outlines FSU based team work deadlines and durations, UFPR based team work deadlines and durations, as well as mutually shared responsibilities.

In regards to resource allocation, Kaelyn and Tomas will be responsible for the design of

the flocculation mechanism, clarifier, and extractor as well as the means by which the recycled medium will be sent back to the photo bioreactor for reuse.

Yuri, Courtne and Benjamin will be responsible for the design of the cultivation preparation component, the cultivation chamber (photobioreactor), the culture preparation, mixing mechanisms and the means by which the photo bioreactor will be connected to the mixing mechanisms. Both parties will be responsible for growing microalgae in their respective locations in order to conduct experiments.

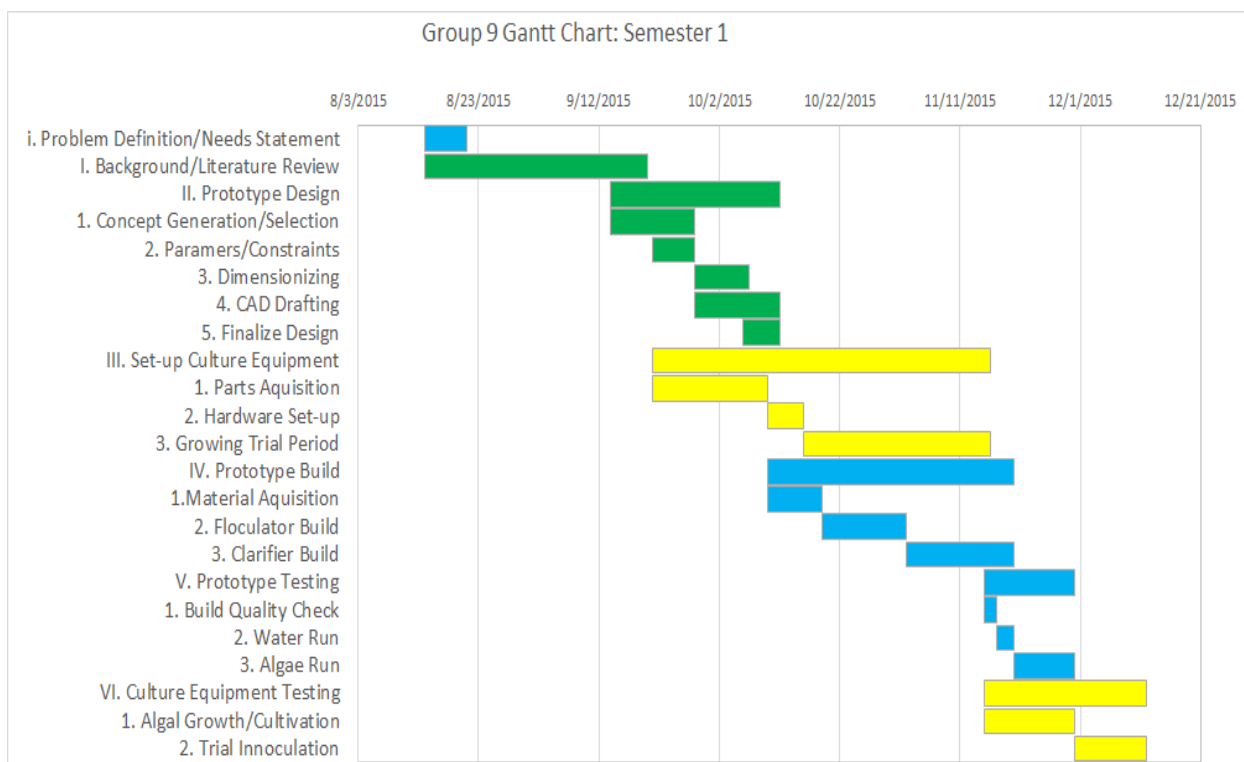

Figure 8. Gantt chart outlining responsibilities for the 2015 Fall semester.

VII. Conclusion

A final design consisting of the components shown in the morphological charts in the concept generation section was reached. This system consists of three main parts, automation and control, cultivation, and harvesting. The cultivation component of the system is comprised of a vertical compartmentalized cultivation tank, using aeration as a form of medium mixing and CO₂ distribution, and solenoid valves to allow or restrict flow when needed. The harvesting component is comprised of the flocculation and clarification processes. The flocculation process consists of two main components, that of initial neutralization of cell charge (coagulation), and second flocculation, gentle mixing for cell agglomeration (flocculation). The final decision of coagulation stage is split between a mechanical method and a chemical method, this will be finalized following the necessary tests. The flocculation will be achieved using bulb like structures for gentle mixing. Following the flocculation process is the clarification, this will consist of a lamella separator and a peristaltic pump for extraction of biomass.

As the design develops many hurdles have had to be overcome and more continue to appear. This causes the design of the system to be very dynamic. Currently the finalized components of the system design are anticipated to meet the current requirements. Those components not yet finalized are being tested to verify which will more efficiently meet those requirements.

VIII. Acknowledgements

Team 9 would like to thank the FIPSE-SEAP Program, as well as the partnership of Florida State University and the Federal University of Paraná for making this senior design project possible. We would like to extend our gratitude to Dr. Juan Ordonez, our sponsor; to Dr. José Viriato Coelho Vargas, our UFPR mentor and coordinator of the Center for Research and Development of Self-Sustainable Energy (NPDEAS); to André Bellin Mariano, the program manager of NPDEAS and principal investigator for this project; and to Diego (INSERT LAST NAME), a UFPR M. Sc. student, for his assistance with process automation.

IX. References

- [1] Yusuf, Christie. 2007. "Biodiesel from Microalgae". *Biotechnology Advances* 25: 294 - 306. Accessed 09/24/2015.
- [2] G. Satyanarayana, A. B. Mariano, and J. V. C. Vargas. 2011. "A review on microalgae, a versatile source for sustainable energy and materials". *International Journal of Energy Research* 35: 291–311. Accessed 09/24/2015.
- [3] Ling Xu, Pamela J. Weathers, Xue-Rong Xiong, Chun-Zhao Liu. 2009. "Microalgal bioreactors: Challenges and opportunities." *Engineering in Life Sciences* 9,3:178-189. Accessed 08/23/2015
- [4] Dries Vandamme, Imogen Foubert, Koenraad Muylaert. 2013. "Flocculation as a low-cost method for harvesting microalgae for bulk biomass production". *Trends in Biotechnology* 31,4: 233–239. Accessed 09/24/2015.
- [5] Sukenik A., Shelef G. 1984. "Algal autoflocculation--verification and proposed mechanism." *Biotechnology and Bioengineering* 26(2):142-147. Accessed 09/24/2015.
- [6] Zechen Wu, Yi Zhu, Weiya Huang, Chengwu Zhang, Tao Li, Yuanming Zhang, and Aifen Li. 2012. "Evaluation of flocculation induced by pH increase for harvesting microalgae and reuse of flocculated medium". *Biosource Technology* 110: 496 - 502. Accessed 09/24/2015.
- [7] Martina Goettel, Christian Eing, Christian Gusbeth, Ralf Straessner, Wolfgang Frey. 2013. "Pulsed Electric field assisted extraction of intracellular valuables from microalgae". *Algal Research* (2).
- [8] D.H. Fax, S.C. Traugott, G.F. Wislicenus. 1952. "Analysis of flow through a sphere". *Oak Ridge National Laboratory* (2).

X. Appendices

A. Appendix A - Flocculation Time Test Results

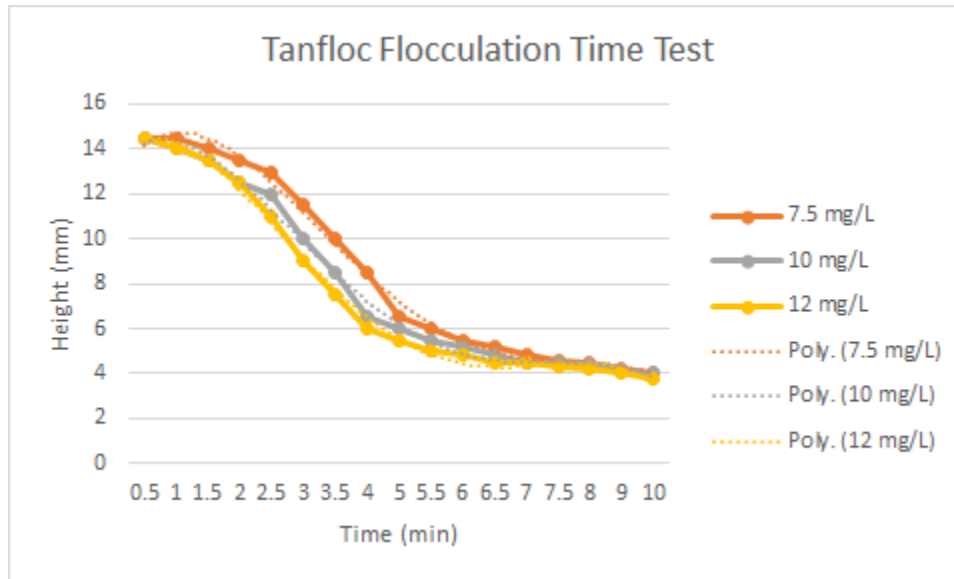

Figure a1. Experimental Tanfloc sedimentation data.

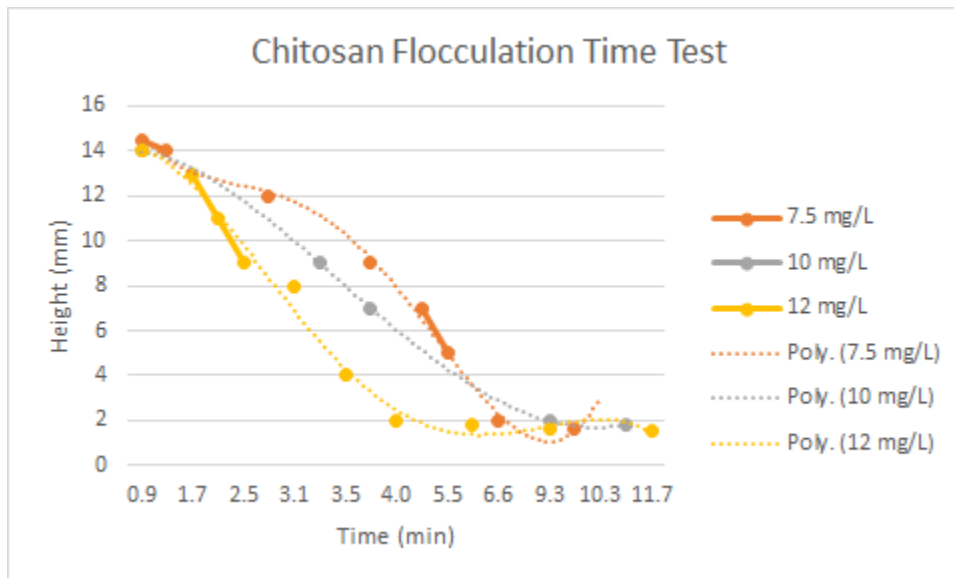











Figure a2. Experimental Chitosan sedimentation data.

B. Appendix B - Conception Generation and Selection Matrices

Option	Solutions		
Function			
Composition Sensors	Volume	Force	Displacement
Mixing			
Structural Design			
Transferring Fluid			

Cultivation Initiative

Figure b1. General morphological chart for all components being developed.

Function: Composition Sensors	Criteria						
	Solutions (Weight)	Cost (2)	Size (1)	Power (2)	Effectiveness (3)	Implementation (2)	Total
1. Mass flow rate sensor		1	8	9	8	7	33
Volume		2	8	18	24	14	66
2. Force sensor (mat)		5	5	8	6	4	28
Force		10	5	16	18	8	57
3. Displacement sensor		10	9	9	6	8	42
Displacement		20	9	18	18	16	81

Figure b2. Decision matrix for sensor used during cultivation process.

AUTOMATED CONTINUOUS HARVESTING SYSTEM FOR MICROALGAE PHOTOBIOREACTORS



Function: Mixing (Medium)	Criteria					
Solutions (Weight)	Cost (2)	Size (1)	Power (2)	Maintenance (2)	Implementation (3)	Total
1. Static Inline Mixer	3	5	10	10	6	34
	6	5	20	20	18	69
Air pump	9	7	6	8	8	38
	18	7	12	16	24	77
Mechanical Mixer	2	4	4	3	4	17
	4	4	8	6	12	34

Figure b3. Decision matrix for mixing mechanism used during cultivation process.



Function: Structural Design	Criteria					
Solutions (Weight)	Cost (2)	Size (2)	Effectiveness (1)	Maintenance (2)	Implementation (3)	Total
1. Erlenmeyer Flasks	2	6	5	8	5	26
	4	12	5	16	15	52
2. Horizontal Tank	6	7	5	4	5	27
	12	14	5	8	15	54
3. Vertical Tank	6	8	9	4	5	32
	12	16	9	8	15	60

Figure b4. Decision matrix for structural design used during cultivation process.



Function: Transferring Fluid	Criteria					
Solutions (Weight)	Cost (2)	Size (2)	Power (2)	Maintenance (1)	Implementation (3)	Total
1. Pump	3	3	2	4	7	19
	6	6	4	4	21	41
2. Auto Syphon	9	8	10	8	3	38
	18	16	20	8	9	71
3. Solenoid Valve	7	9	8	7	7	38
	14	18	16	7	21	76

Figure b5. Decision matrix for mechanism used to transfer fluids during cultivation process.















Option 1	Solutions		
Function			
Composition Sensors	Volume 	Force	Displacement
Mixing			 
Structural Design		 	
Transferring Fluid	 		 

Fig b6. Morphological chart showing all selected components for option 1













Option 2	Solutions		
Function			
Composition Sensors	Volume	Force	Displacement 
Mixing		 	
Structural Design			 
Transferring Fluid			 

Fig b7. Morphological chart showing all selected components for option 2.

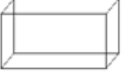









Option 3	Solutions		
Function			
Composition Sensors	Volume 	Force	Displacement
Mixing	 		
Structural Design			 
Transferring Fluid		 	

Fig b8. Morphological chart showing all selected components for option 3.

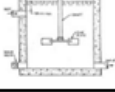
Harvesting Initiative

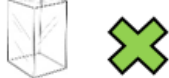

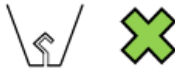









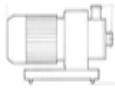

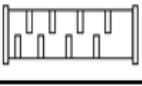

Option	Solutions				
Function					
Mix-Coagulation					-
Mix-Flocculation					-
Clarification					-
Extraction					

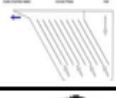
Figure b8. General morphological chart for all components being developed.

AUTOMATED CONTINUOUS HARVESTING SYSTEM FOR MICROALGAE PHOTOBIOREACTORS



Function: Mixing (Coagulation)	Criteria					
Solutions (Weight)	Cost (2)	Size (1)	Power (2)	Maintenance (2)	Viability (3)	Total
1. Static Inline Mixer	8	9	10	7	6	40
	16	9	20	14	18	77
2. Aeration	9	5	6	5	7	32
	18	5	12	10	21	66
3. Inline Kinetic Mixer	2	7	4	3	5	21
	4	7	8	6	15	40
4. Kinetic Mix Tank	5	5	2	5	9	26
	10	5	4	10	27	56

Figure b9. Decision matrix for coagulative mixing mechanism used during harvesting process.

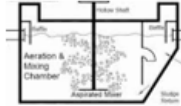
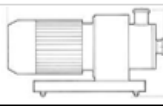

Function: Mixing (Flocculation)	Criteria					
Solutions (Weight)	Cost (2)	Size (1)	Power (2)	Maintenance (2)	Viability (3)	Total
1. Static Inline Mixer	8	9	10	7	6	40
	16	9	20	14	18	77
2. Mixing Bulb	9	8	10	8	8	43
	18	8	20	16	24	86
3. Baffles	10	9	10	6	8	43
	20	9	20	12	24	85
4. Kinetic Mix Tank	5	5	2	5	9	26
	10	5	4	10	27	56

Figure b10. Decision matrix for flocculation mixing mechanism used during harvesting process.

AUTOMATED CONTINUOUS HARVESTING SYSTEM FOR MICROALGAE PHOTOBIOREACTORS



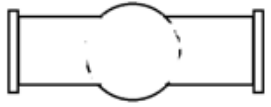
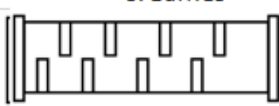

Function: Clarification	Criteria					
Solutions (Weight)	SA (3)	Cost (1)	Implementation (2)	Effectiveness (3)	Novel (1)	Total
1. Parallel Lamella Plates 	6	10	10	5	1	32
	18	10	20	15	1	64
2. Conical Arrangement Lamella Tubes 	5	7	4	7	7	30
	15	7	8	21	7	58
3. Parallel Angled Lamella Tubes 	9	8	8	8	5	38
	27	8	16	24	5	80
4. Parallel Angled Corrugated Lamella Plates 	10	7	8	10	7	42
	30	7	16	30	7	90

Figure b11. Decision matrix for clarification structure used during harvesting process.



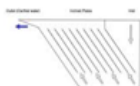

Function: Biomass Extraction	Criteria						
Solutions (Weight)	Cost (2)	Power (1)	Novel (2)	Viability (1)	Maintenance (2)	Effectiveness (2)	Total
1. Pump 	1	5	1	10	6	10	33
	2	5	2	10	12	20	51
2. Cam Swallow Mechanism 	4	6	8	6	4	7	35
	8	6	16	6	8	14	58
3. Conveyor/Scrubber 	5	6	5	7	4	8	35
	10	6	10	7	8	16	57
4. Autosiphon 	7	8	5	7	5	2	34
	14	8	10	7	10	4	53
4. Free Fall Valve 	8	8	1	8	8	2	35
	16	8	2	8	16	4	54

Figure b12. Decision matrix for extraction mechanism used during harvesting process.

AUTOMATED CONTINUOUS HARVESTING SYSTEM FOR MICROALGAE PHOTOBIOREACTORS













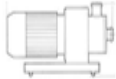

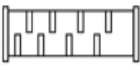

Option 0 - Control	Solutions				
Function					
Mix-Coagulation				 X	-
Mix - Flocculation				 X	-
Clarification	 X				-
Extraction	 X				

Fig b13. Morphological chart showing all selected components for control option.















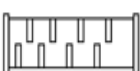

Option 1	Solutions				
Function					
Mix-Coagulation	 X				-
Mix - Flocculation		 X			-
Clarification				 X	-
Extraction		 X			

Fig b14. Morphological chart showing all selected components for option 1.

AUTOMATED CONTINUOUS HARVESTING SYSTEM FOR MICROALGAE PHOTOBIOREACTORS











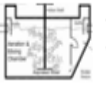
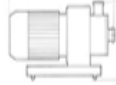

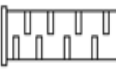

Option 2	Solutions				
Function					
Mix-Coagulation		 X			.
Mix-Flocculation			 X		.
Clarification			 X		.
Extraction			 X		

Fig b15. Morphological chart showing all selected components for option 2.











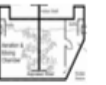
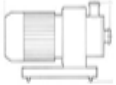

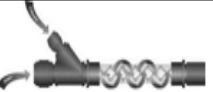

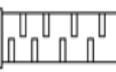
Option 3	Solutions				
Function					
Mix-Coagulation	 X				.
Mix-Flocculation			 X		.
Clarification				 X	.
Extraction			 X		

Fig b16. Morphological chart showing all selected components for option 3.

	Baseline	Alternative Solutions		
Criteria	Current Solution	Option 1	Option 2	Option 3
Cost	4	2	1	1
Sustainability	1	1	0	0
Adaptability	3	0	-1	0
Maintenance	2	1	-1	0
Effectiveness	5	1	0	1
Σ Positives	-	16	4	9
Σ Negatives	-	0	-5	0
Total	-	16	-1	9

Fig b17. Pugh matrix used to justify choice of option 1 as best design combination for the harvesting process..

C. Appendix C - CAD for Chosen Concept Designs

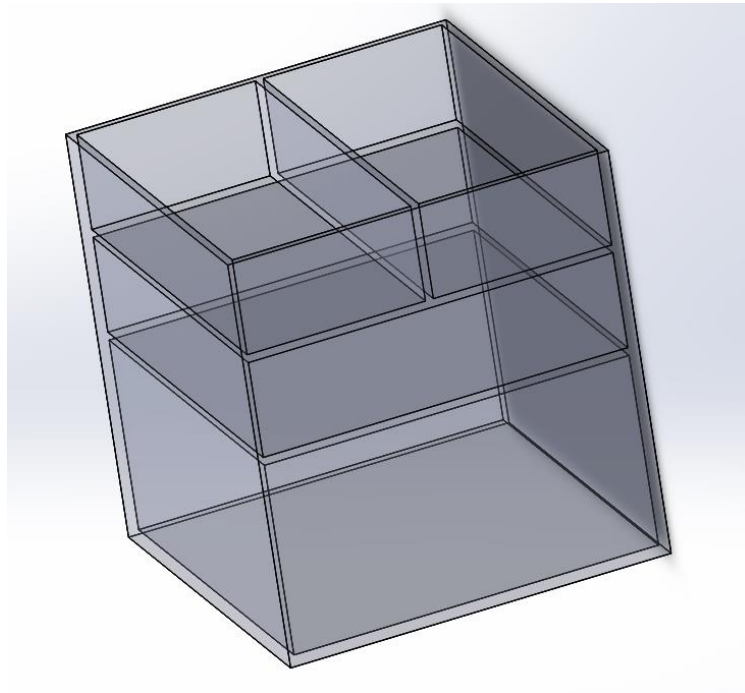

Fig c1. Cultivation design prototype

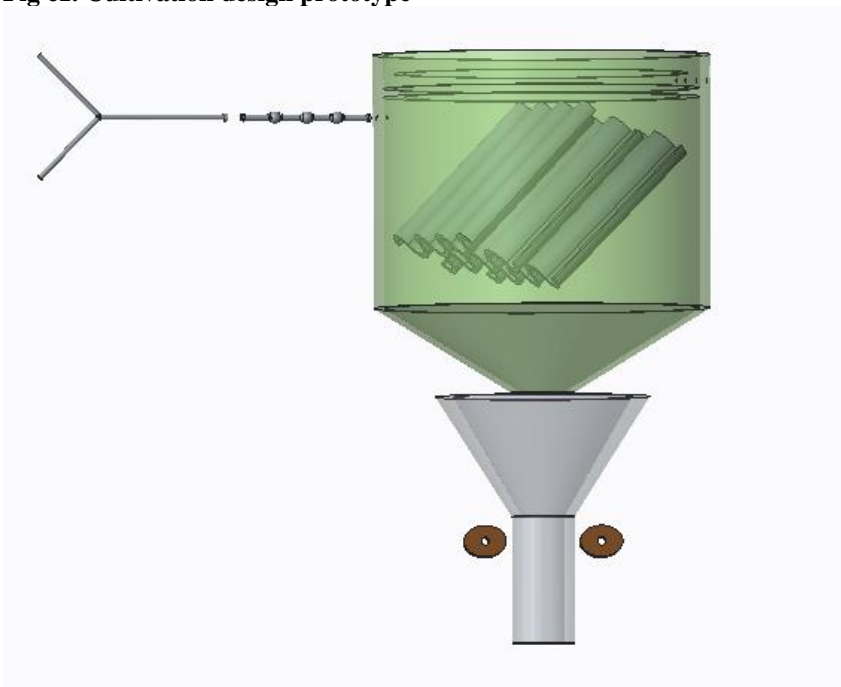

Fig c2. Harvesting design prototype

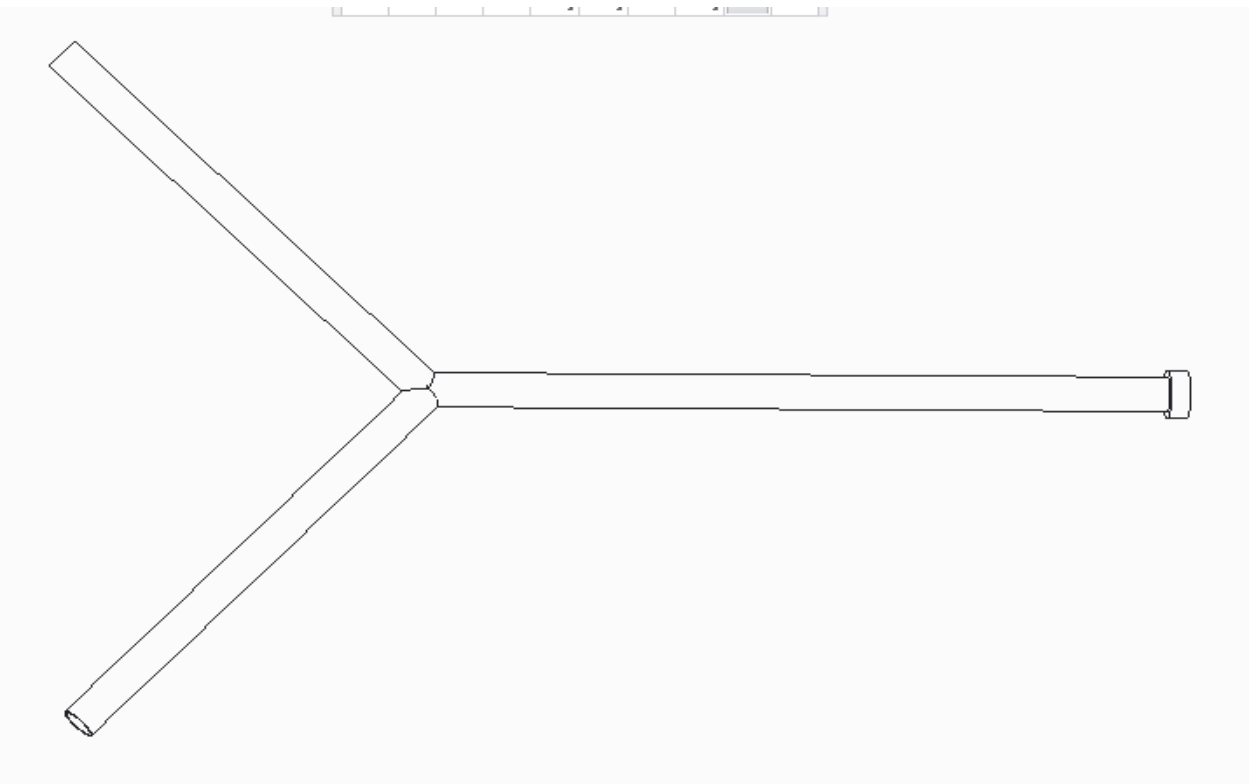

Fig c3. General concept cad of static inline mixer with double input.

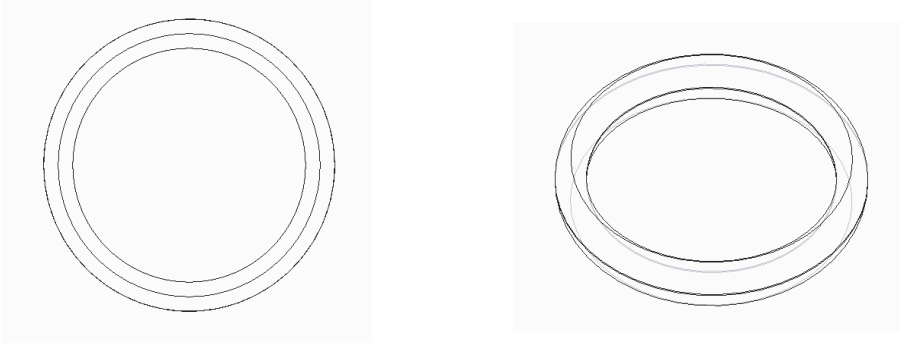

Fig c4. Concept cad of seal used at piping junctions.

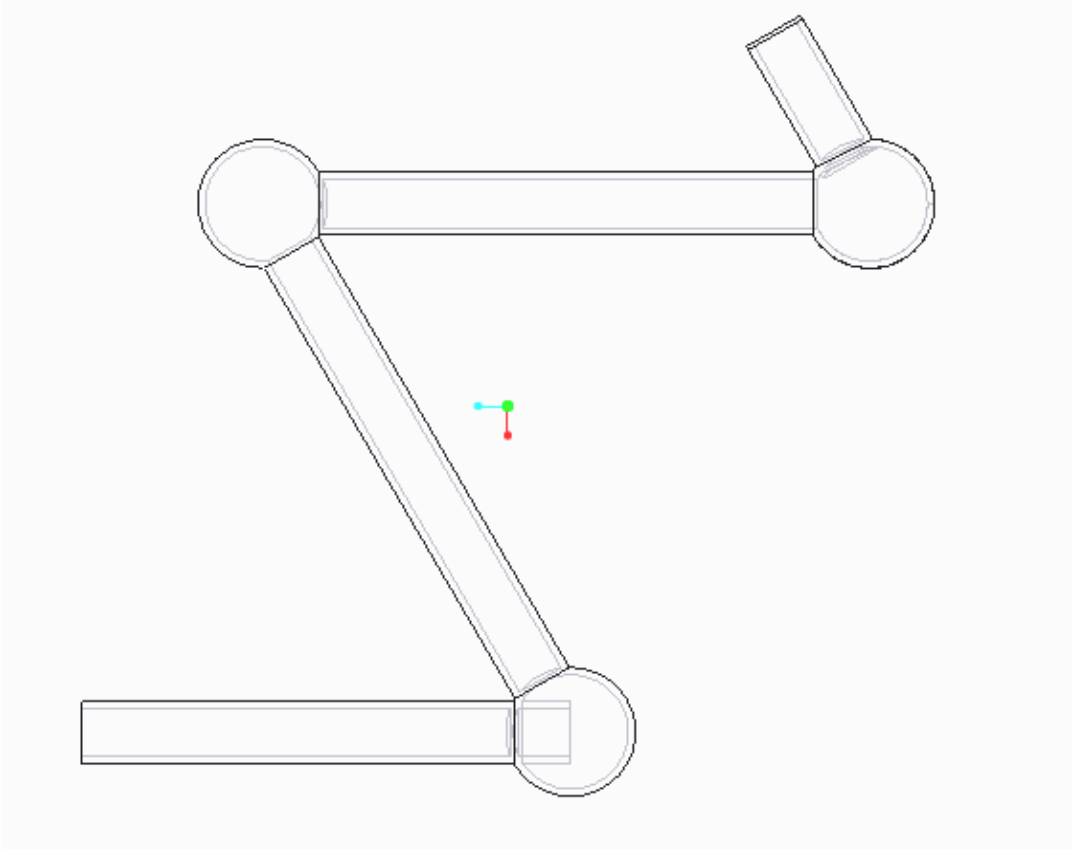

Fig c5. Concept cad of bulb mixing mechanism

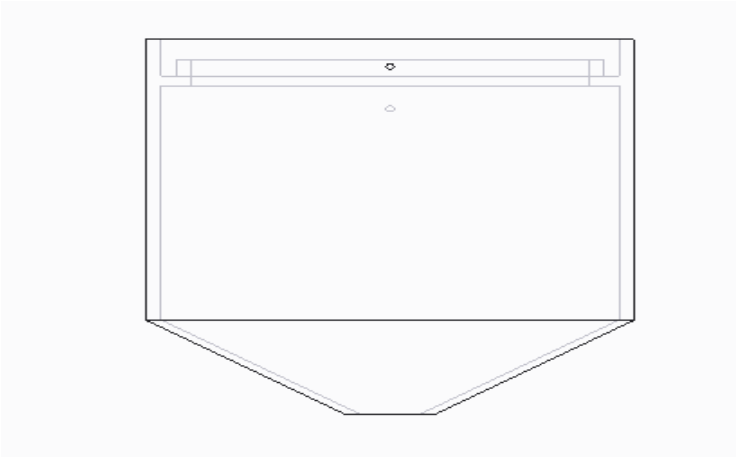

Fig c6. Concept cad of clarification tank.

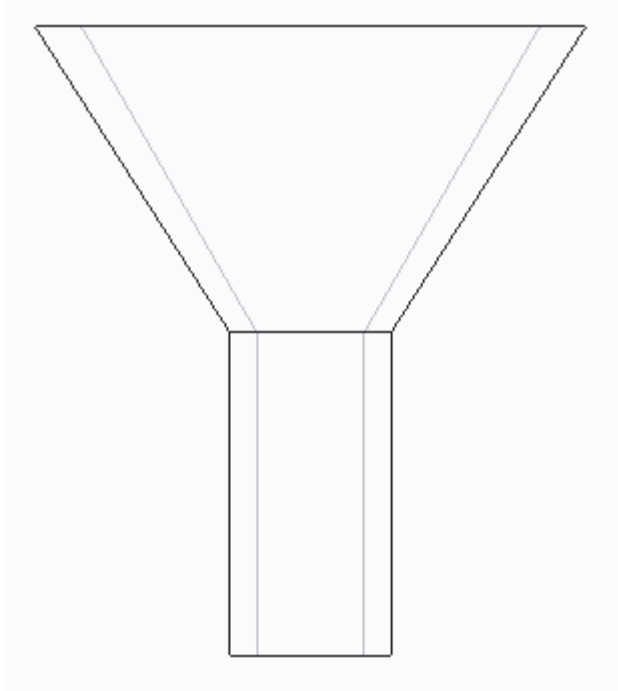

Fig c7. Concept cad of flexible portion of cam extraction mechanism.



Fig c8. Concept cad of cam used for extraction.



Fig c5. Concept cad of corrugated lamellae structure.

D. Appendix D - Additional Information

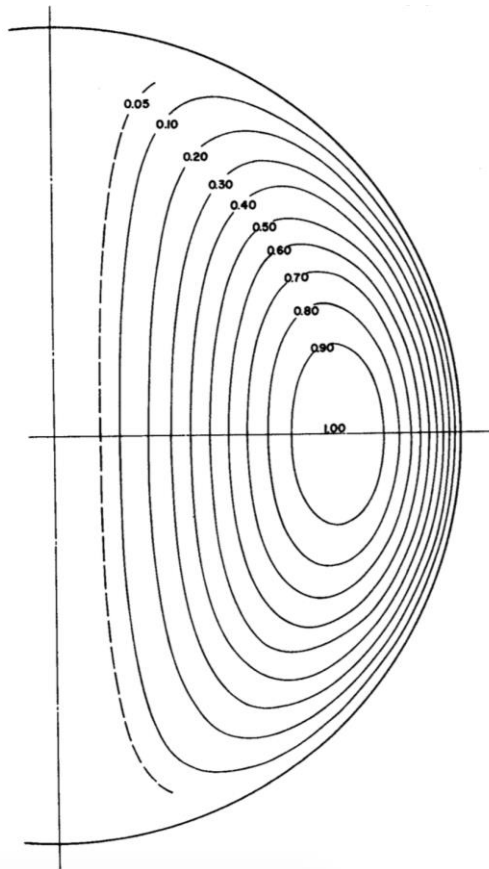

Figure d1. Flow regime within a sphere for the proof of concept of bulb mixing.

E. Appendix E - Risk Assessment Safety Plan