

Term I Final Report

Team 12

Development of Hammer Blow Test to Simulate Pyrotechnic Shock



Members:

Luis Lopez (lel12b@my.fsu.edu)
Max Mecabe (mwm12@my.fsu.edu)
Tiffany Shaw (tas12e@my.fsu.edu)
Justin Vigo (jlv11b@my.fsu.edu)
Sarah Wyper (saw10f@my.fsu.edu)

Faculty Advisor:

Dr. Rajan Kumar (rkumar@fsu.edu)

Sponsor: Harris Corporation

Robert Wells (rwells01@harris.com)

Instructors:

Dr. Nikhil Gupta (ng10@my.fsu.edu)
Dr. Chiang Shih (shih@eng.fsu.edu)

12/7/15



Table of Contents

Table of Figures.....	ii
Table of Tables.....	iii
Acknowledgements.....	iv
ABSTRACT.....	v
1. Introduction.....	1
2. Project Definition.....	2
2.1 Background research.....	2
2.2 Need Statement.....	3
2.3 Goal Statement & Objectives.....	3
2.4 Constraints/Requirements.....	4
3. Design and Analysis.....	6
3.1 Previous Design.....	6
3.1.1 Data Acquisition/SRS Curves.....	6
3.1.2 2015 Test Rig Design.....	7
3.1.3 Pros and Cons of Design.....	9
3.2 Design Concepts.....	11
3.2.1 Hammer.....	11
3.2.2 Decoupling.....	12
3.2.3 Stability.....	13
3.2.4 Design Variations.....	14
3.3 Evaluation of Designs	14
3.3.1 Hammer.....	14
3.3.2 Spring.....	15
3.3.2 Stabilization.....	18
3.4 Final Design Implementations.....	20
4. Project Management.....	22
4.1 Risk and Reliability Assessment.....	22
4.2 Procurement.....	24
4.3 Updated Gantt Chart and Resource Allocation.....	24
5. Environmental and Safety Issues and Ethics.....	25
6. Results and Conclusion.....	26

References.....	27
Appendix 1- Gantt Chart.....	28
Appendix 2- CAD Models.....	29
Appendix 3- Risk Assessment.....	33

Table of Figures

Figure 1 - Previous Damped and Undamped SRS Curves.....	7
Figure 2 - Photograph of Last Year’s Test Rig.....	8
Figure 3 - Front view of last year’s test rig.....	8
Figure 4 - Side view of last year’s test rig.....	9
Figure 5 - Proposed design for hammer’s pivot mechanism	12
Figure 6 - General concept for spring isolators and all four attached to fixture plate.....	13
Figure 7 - General concept for decoupling fixture plate via suspension.....	13
Figure 8 - Sketch of initial and final states of hammer in new configuration.....	15
Figure 9 – Graph of Spring Constant vs. Compression Distance.....	18
Figure 10 - Foot 45 GD.....	19
Figure 11 - Newport Series Optical Table.....	20

Table of Tables

Table 1 - Requirements Provided by Harris for Second Year Project	4
Table 2 - Reusable cost analysis from last year's team.....	10
Table 3 –Decision matrix to increase frame's stability.....	18
Table 4 - FMEA Table for Reliability Analysis.....	23

Acknowledgements

The members of Team 12 would like to express our great appreciation to our sponsor, Harris Corporation and the FSU-FAMU College of Engineering faculty; this project would not be possible without their help. We would like to thank Mr. Robert Wells and his colleagues at Harris for providing this project and for their contributions of both time and resources to help get us pointed in the right direction. We would also like to acknowledge our faculty advisor, Dr. Kumar for his guidance and allocation of important resources. Lastly, our senior design instructors Dr. Gupta, and Dr. Shih for helping us with the planning and execution of this design task.

ABSTRACT

In order to ensure safety and a properly functioning system, thorough tests need to be done on every operational part. This is especially true for systems that encounter and make use of pyrotechnic shock. Many advanced systems use controlled explosive devices to accomplish tasks. Examples include rocket separation, pilot ejection, and air bag deployment. During these events it is critical that the components involved with the explosion and those surrounding it, especially the electronics, maintain functionality. This project aims to improve upon the pyrotechnic shock testing system that currently exists at Harris Corporation. A hammer blow impact test device has been built by a previous design team, but the resulting data lacked consistency and repeatability which provided little insight. The goal of this year's team is to capitalize off of the work of the previous design team while also implementing the necessary design changes in order to produce a repeatable pyroshock test that can be used to gain further understanding of the variables involved with pyroshock testing. To accomplish this several design changes were proposed and analyzed. The appropriate design changes that should be implemented consist of: a bearing hinge at the hammer pivot point, decoupling the frame and plate using a suspension system, stabilizing the entire device via anchoring, and making use of an electromagnetic release mechanism. So far the device has been anchored and the pivot has been replaced. The next steps in the project include trying to obtain repeatable results while also looking into electromagnetic release mechanisms and decoupling of the strike plate. Once repeatable results are obtainable, tests will be run in order to determine how variables affect SRS curve results.

1. Introduction

Currently at Harris Corporation there exists a device to test high frequency impacts as a result of explosions. These high frequency impacts are meant to simulate what is referred to as pyrotechnic shock or pyroshock. It is important to analyze how these shocks affect electronic components because they typically occur within a close range of hardware that is crucial to the integrity of the system. The current device at Harris Corporation is capable of replicating pyroshock, but due to the nature of pyroshock it is difficult to create repeatable test data. As a result, a great deal of time and resources have been invested in understanding the nature of shock response. The goal of this project is to create a device that simulates pyroshock in a repeatable manner so that researchers can gather meaningful data in order to further their understanding of the effects of pyroshock by changing several different parameters. These variables include strike force, strike location, and sensor location. This is the long term, final goal for the project.

It is important to note that this project is a continuation from Team 15's work last year. Team 15 set out to achieve the same goals, but were unable to accomplish the task in one school year. It is also important to note that Team 15 encountered many of the same issues that affected Harris' current device and which contributed to the ideation of the project. Within the provided school year the team was able to produce a working test device that simulates pyroshock, but the device struggles with repeatability and therefore cannot provide much insight for Harris in its current state. It is our goal to use the results from Team 15's efforts to create a device that produces accurate repeatable experimental data. This report will provide an in-depth analysis of the project definition, along with the design and analysis that will be used to accomplish the task at hand and the methodology for implementing these ideas.

2. Project Definition

2.1 Background Research

Pyrotechnic shock can result in violent reverberation of a material or structure as a result of the high force explosion or impact. Beyond the conventional use of explosives to cause intended damage, controlled explosions can be used to accomplish tasks. It is not uncommon for explosives to be used in various applications in the aerospace industry. Examples of this include but are not limited to rocket separation, pilot ejection, airbag inflation, and payload deployment [1]. It is of significant importance that the components that are surrounding or involved with the explosions survive the occurrence and are able to complete their tasks resulting in a successful outcome rather than a failure after detonation.

Numerous methods exist for replicating and analyzing pyroshock, but in general most computational models encounter difficulty with the resources required. These difficulties often stem from a combination of the large forces involved and the very large frequency at which they occur. Finite element analysis (FEM) encounters such an issue modeling the shock due to its high frequency characteristics [2]. Most commonly used to record the results of such a test is what is referred to as the Shock Response Spectrum or SRS. The SRS facilitates the analysis of shock on the component in the frequency domain, rather than transient shock in the time domain. The SRS shows peak acceleration of a predetermined series of natural frequencies that would be imparted by a certain shock [2].

Some options for simulating the shock are using a shaker to induce vibrations, or using mechanical shock inputs, like hammer blow or pneumatic tests. A shaker has been ruled out of consideration as the fast decay and extreme frequencies are difficult to simulate with such a system [2]. The mechanical options are more viable options, but can be time consuming when tuning [2]. Additionally, the shock usually cannot be subjected directly to the component in testing, but through a mounting, which could have significantly different mechanical properties and thus

affecting the results [2]. High acceleration shock loadings are obviously most accurately created by explosives; however, this is not feasible due to easily imaginable hazards [2].

Electronic components have also been shock tested through the use of drop tests, but it has been found that these tests tend to overestimate the shock accelerations and their resulting damage. Harris Corporation has also found this to be the case through their research. Also some sources have noted error do to the use of an accelerometer to record measurements of pyroshock, but these issues can be potentially solved through the use of mechanically simulated pyroshock as opposed to the use of actual pyrotechnics.

2.2 Need Statement

Harris Corp. has expressed a need for an apparatus enabling an accurate simulation of pyrotechnic shock via a hammer mechanism. The first prototype constructed the previous year, while fulfilling its purpose of gathering information on high load and high frequency shock, yielded noisy data as a result of too many parameters and high tolerances within the structure of the mechanism [3]. A device that is more stable and that would yield more repeatable results is desired in order to test the variables surrounding pyrotechnic shock.

There is a need to gather knowledge and data involved with pyrotechnic shock and the variables that affect it.

2.3 Goal Statement and Objectives

Optimize the test device's stability and repeatability and in turn develop a better understanding of relations between various test fixture parameters and resulting SRS curves.

Objectives [3]:

- Research existing methods for simulating and testing shock responses
- Improve repeatability of last year's test device
- Improve hammer mechanism stiffness and release from last year's device
- Evaluate designs in order to decouple the attachment of plate to frame

- Optimize processing for modeling SRS curves
- Improve FEM analysis process using results from improved test device
- Reduce set of parameters used for tests from last year
- Perform impact tests with improved device and improved modeling

An additional goal, if time permits, is to work on adding damping effects, more mass, and stiffeners to the fixture plate and analyze these results against the previous ones [3]. Table 1 displays what was specifically provided by our sponsors at Harris.

Table 1- Requirements Provided by Harris for Second Year Project

Requ. #	Category	Description
1	Mechanical	Refine impact test device and fixture plate developed on year 1 project to improve repeatability.
2	Mechanical	Evaluate SRS generation from year 1 project and develop improvements to speed up processing
3	Mechanical	Fabricate design improvements and validate repeatability. Use results to improve FEM analysis process.
4	Mechanical	Perform impact test on fixture under a reduced set of test parameters. Test parameters to be identified by Harris by SDR.
5	Cost	Bill of Materials shall be generated early enough to budget costs for test fixture improvements and any needed instrumentation purchases
6	Mech (stretch goal)	Evaluate ability to tune fixture plate by adding damping, mass, stiffeners. Correlate results to FEM analysis

2.4 Constraints/Requirements

Rather than creating an entirely new testing apparatus for shock testing, the primary issue faced by Harris is not that the current hammer blow test is not an effective means of generating the desired pyrotechnic shocks, but that it is currently inefficient due to required trial and error time beforehand. Therefore, if we were to focus our efforts on better modeling the current system and finding ways to reduce the number of necessary trial runs, our constraints are then limited only to the current models used for testing.

- Device capable of testing unit between 5-50 lbs
- Must accommodate a parcel of dimension up to 16" L x 16" W

- Must generate SRS pyrotechnic shock responses of up to 5000g peak and 10kHz (max levels for mid field range shocks)
- Response must be captured by an analysis system
- Test parameters must be controllable through accessible software tool (MATlab)
- Project expenses must stay within allotted budget (\$5000)

It is important to note that although the proposed design changes should work within these parameters, there is always room for adjustment if it is agreed upon between the team and our sponsors at Harris that a change would provide for a better viable outcome. Also other typical constraints regarding the size of the machine, the required material used, and so forth, are not included in this section because to this point, no such constraints exist. We are planning to make use of sensors and software available at the school to the highest extent we can. The material choice, for example, is purposefully not a constraint as it represents a variable of the shock generation process that we are able to explore as a way to better control the parameters of shock testing.

3. Design and Analysis

3.1 Previous Design

This project was split into several parts and goals stretched over a period of more than one year mostly because of the intrinsic difficulties that lie in the nature of this project. Last year's goal was to create "smaller scale proof-of concept adaptable test rig" whereas this year goal is to "explore further adaptability at higher force levels." Last year's senior design team created a data acquisition, SRS generation, and data analysis process as well as a "small scale" test rig. These design components are gone into detail further below.

3.1.1 Data Acquisition/SRS Curves

When measuring the shock response of the impact test, one can plot the data to obtain an exponentially decaying sinusoidal function of the accelerations in the time domain. The chaotic nature of these plots makes it difficult to draw any significant conclusions about the behavior of the shock response. For this reason, last year's team and Harris developed a modeling software that transforms the shock response from the time domain to the frequency domain by way of a discrete convolution integral. The resulting shock response spectrum, or SRS curves, are more telling of the resultant accelerations at the different frequencies in the fixture plate. We are interested in the shock response at frequencies around 10kHz, so for this reason the accelerometer used must be able to sample at a rate of at least 20kHz to avoid any undesired effects from aliasing. We intend on using the same transducer used by last year's team - a Dytran 3086A4T accelerometer that will be connected to a similar DAQ system.

This year we are hoping to make more progress with regards to testing under different parameters in order to build various relations between these parameters and the resultant SRS curves. For example, last year's time generated SRS curves for both damped and undamped fixture plates which resulted in the SRS curves in Figure 1.

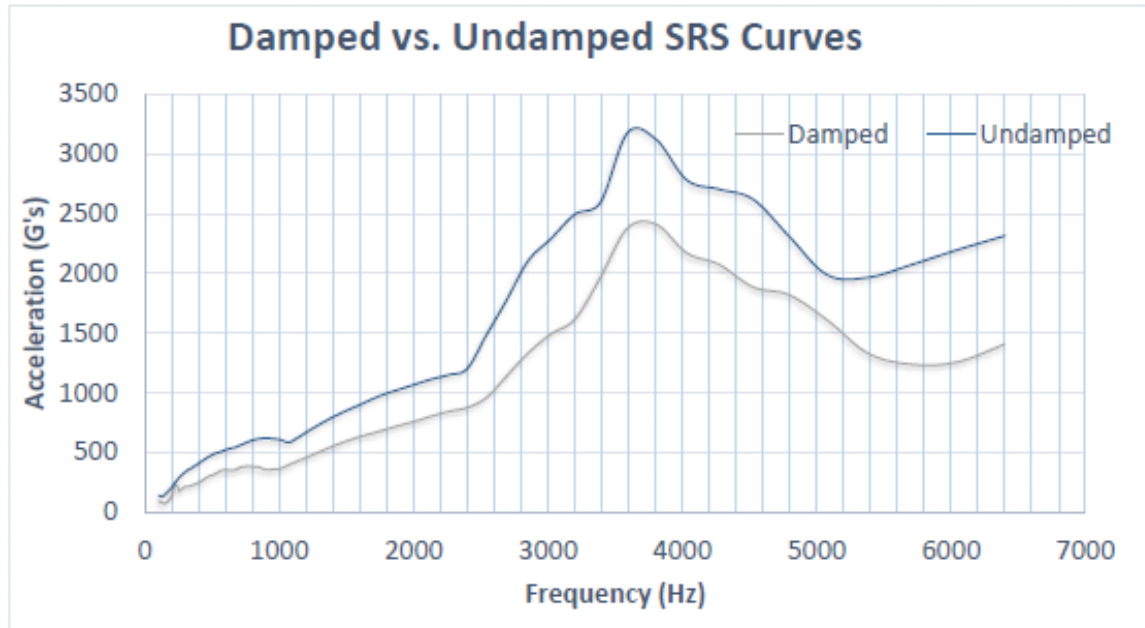

Figure 1: Example of SRS curves generated by the previous year's team

3.1.2 2015 Test Rig Design

Last year's test rig is pictured below in Figure 2. The main components of the design include the frame, which is 34'' by 34'' and made from T-slotted aluminum rods. The fixture plate which is the large plate in the center, which is 31.625'' by 31.625'', is made of Aluminum 6061. The hammer is composed of the arm and head. The arm is made from the T-slotted Aluminum frame, and the head is made from two 7075-T6 Aluminum blocks, which are both 3'' x 3'' x 4''. Lastly, the object of interest or test article is a small square of metal in the center of the fixture plate (not shown - other side of the fixture plate).



Figure 2. Photograph of Last Year's Test Rig

Below are more detailed CAD drawings of last year's design.

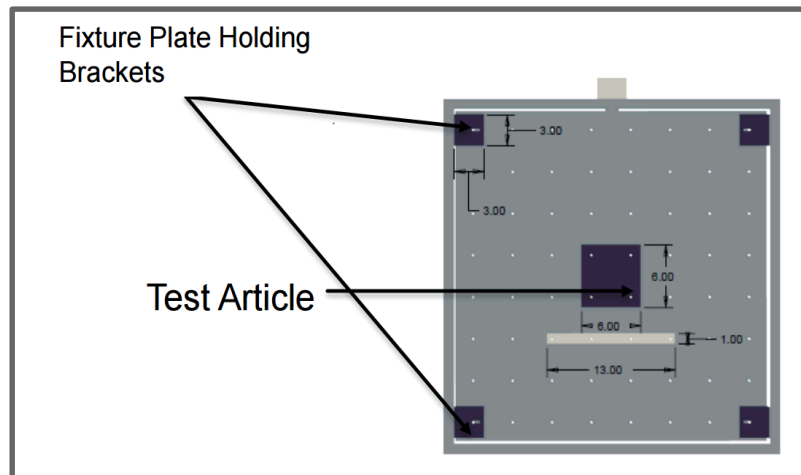

Figure 3. Front view of Last Year's Test Rig [inches]

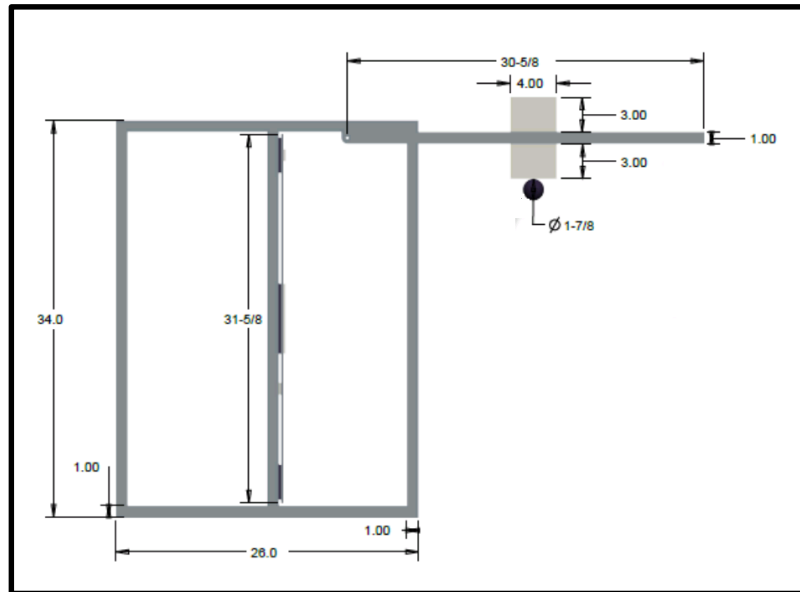

Figure 4. Side view of Last Year's Rig [inches]

The original design iteration of last year's team utilized a heavier steel frame, which helped to weigh down the entire mechanism and provide stability. However, they ended up opting for a lighter T-slotted Aluminum frame. This allowed for variability in the fixture plate to be explored, such as changing location or thickness of the plate. It also allowed for hammer arm transition along the x-axis and hammerhead transition along the hammer arm itself. Although this variability will not be explored until repeatable results are produced by this year's design team, the T-slotted frame still provides valuable experimental variability. Not only did last year's team vary the test article location and the hammer impact location with the aid of the slotted frame, but they also varied the hammer tip shape and explored the tunability of the test plate. They did so by attaching several varying tuning bands to the larger fixture plate and obtained some interesting results. When the fixture plate was tested under damped conditions, the amplitude in g-forces were decreased. The amount of this decrease varied due to the variation of the test, and its inability to provide consistent results.

3.1.3 Pros and Cons of Design

After building this test rig and running it several times with the various experimental variables, certain specific design weaknesses were found to be inherent to this model. The first alludes to the

inability for this design to be secured to the ground or wall, which is necessary since it in itself does not provide enough stability to prevent noise as a result of the frame, which interferes with the data. The second involves the SRS curve generation which could be more time efficient. One of the most prominent weaknesses in this design is the hammer arm gyration which is significantly large. This is the main source that makes repeatable tests nearly impossible. The anticipated maximum force that was hoped to be generated by last year's test rig was about 6000 g (g-force) with their 8.31 lb. hammer. However, in the subsequent SRS curves, it is apparent that only about 3000 g were obtained.

It is important to talk about the cost analysis affiliated with this design. Since this year's team is given the opportunity to utilize the old test rig equipment, there may be means in this year's budget to explore more expensive design variations.

Table 2: Reusable Cost Analysis from Last Year's Team

Item/Items	Amount Spent Last yr	Will be reused	Will Need Additional Money Allocated
Frame	\$537	Yes	Yes
Fixture Plate	\$324	Yes	No
Hardware	\$53	Yes	Yes
Test Article	\$44	Yes	No
Hammer	\$173	Yes	Yes
DAQ	\$960	Yes	Yes

Although additional money will need to be spent in some areas, by reusing the entire design the team will be saving roughly 2,000 dollars. Also the additional money that will be allocated to the necessary areas is mostly small amounts except for the DAQ system. It is important to note here that cost analysis is specific to the budget of our senior design team. This design is not meant for a profitable, sellable, and manufacturable product. Although this is not out of the question for hammer blow tests, it will likely not be the case, and certainly is not here.

3.2 Design Concepts

We will be utilizing a modular design approach, meaning we will be looking at specific subsystems separately, rather than the entire design as a whole. This is in part due to the fact that a completed design already exists, and we will aim at optimizing its many issues in order to produce meaningful and reproducible results. The various subsystems that will be the main focus are described below and include the hammer gyration, decoupling the fixture plate from the main frame, and stabilizing the frame itself.

3.2.1 Hammer

A current issue with the hammer being utilized is that it is not heavy enough to produce the g-forces that are desired of the test rig. One solution to this problem would be to use an actuator to drive the hammer arm at an increased velocity in order to generate the forces necessary. A simpler approach is to use a heavier hammer. Since the rig currently relies on gravity to drive the hammer a heavier object would produce a larger impact force. Implementing this idea is also much easier than trying to fix an actuator to the hammer arm. The disadvantage to just using gravity is that there is less variability in how the test is performed, but this can be looked into at a later point in the project.

A second variable that is a part of the current design is the pivot point of the hammer arm. The hammer pivots about screws, as opposed to a bearing hinge. The resulting play in the hammer's motion is so severe that it would be objectionable to say that the hammer is operating under one degree of freedom as there is currently an approximate 5 degree arc about the pivot point on which the hammer can strike. A better pivot point would tighten the tolerance of the hammer motion and restrict it to just one path of motion. With a more secure pivot point, more reliable and consistent test results can be produced from the test rig. The proposed design would utilize a bearing hinge that would attach the hammer arm to the rest of the frame (see Appendix 2 for detailed drawings).

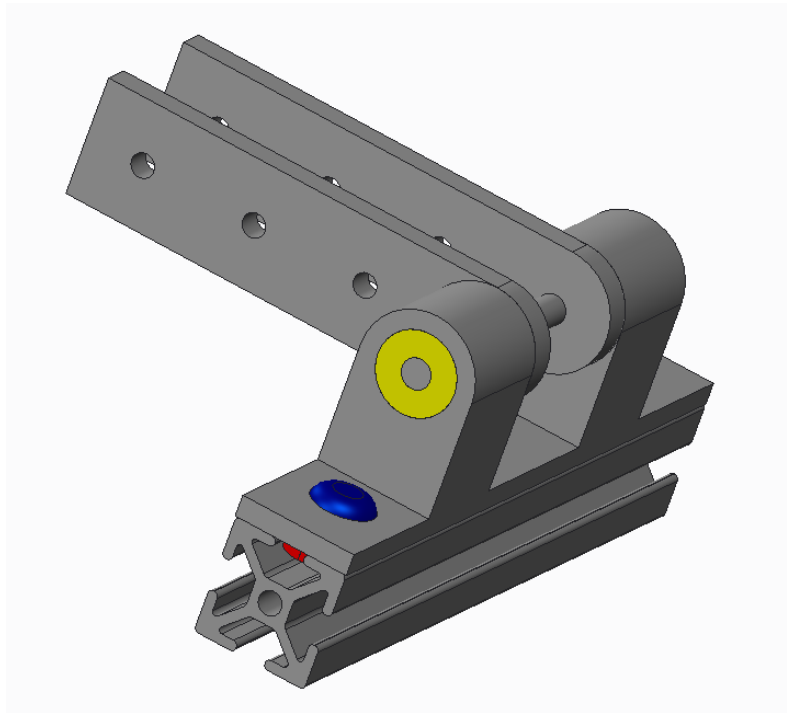

Figure 5: Proposed design for hammer's pivot mechanism

3.2.2 Decoupling

Our sponsors at Harris have expressed an interest in decoupling the fixture plate from the test rig. Hopefully by isolating the fixture plate from the rest of the frame, the data that is recorded will not be influenced by the test frame vibrating due to the impact of the hammer. We can achieve this by either mounting the fixture plate on springs at its four mount points (Figure 8), or by suspending the fixture plate from the frame via some sort of suspension (Figure 9). The idea behind these two concepts is that the elastic components will decouple the fixture plate from the rest of the apparatus, thus greatly reducing the coupled dynamic effect from the frame.

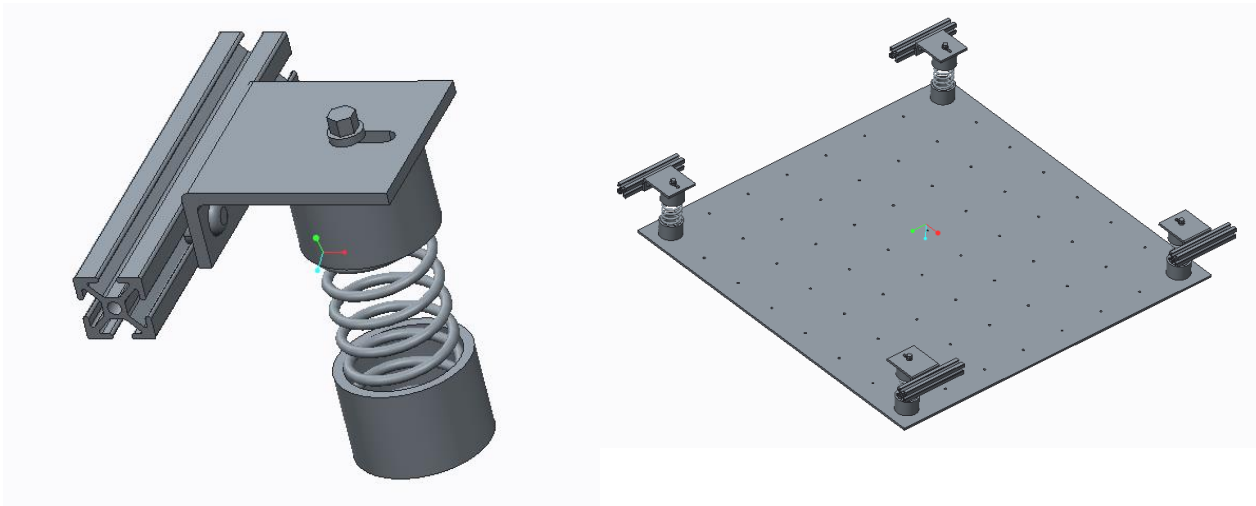

Figure 6: General concept for spring isolators (left), and all four attached to fixture plate (right)

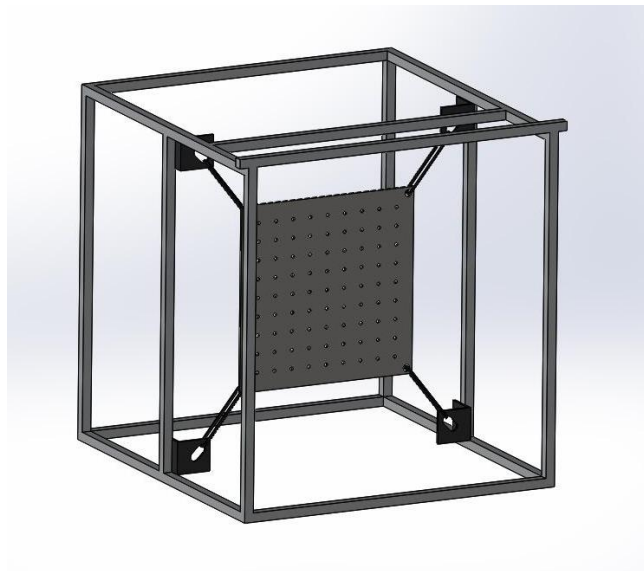

Figure 7: General concept for decoupling fixture plate via suspension

3.2.3 Stability

Since the vibrations of the test rig are not ideal for the data acquisition, making the whole frame more stable is a requirement. One way to accomplish this is to mount the test rig onto a heavy plate so the frame cannot slide around. By not allowing the frame to slide or move will reduce the vibrations and will lead to more accurate data being collected. Another possible solution is to fix

the frame with vibration reducing legs that will lessen the amount the frame moves when the hammer impacts the plate. Both solutions have their disadvantages though, the heavy plate restricts the mobility of the frame and the legs might not reduce the vibrations enough to create good data.

3.2.4 Design Variations

Once the aforementioned design concepts for each subsystem are narrowed down, they will be employed by Team 12 this year, after and during which testing and SRS curve generation will commence. When repeatable results have been generated, then other design elements will be considered. These will be discussed with the sponsors at Harris Corp. further at later dates. This is mostly due to their main concern that repeatable results will not be obtained since this high frequency, high acceleration set is extremely hard to control and predict. Design variations such as test plate varying, tuning of fixture plate, and varying hammer weights will be discussed and analyzed under the exciter section later in this report. Again, this is because the sponsors do not want them to be pursued until the initial goal is met.

3.3 Evaluation of Designs

3.3.1 Hammer

Visual inspection of the hammer blow device in both the vertical and horizontal configurations indicate that the new configuration could be more stable since the force of the impact is being driven into the ground. The maximum forces on the new design for the pivot mechanism would be imparted on the aluminum pin running through both bearings. These radial forces can be expressed by

$$F_r = (m_1 * v_1^2) / r \quad (1)$$

where v_1 can be substituted from Equation 1 to obtain the relation

$$F_r = 2 * m_1 * g \quad (2)$$

but since this force is distributed amongst two surface points of contact, each individual contact point will experience a maximum force of

$$F_r = m_1 * g \quad (3)$$

The pin is 0.25” in diameter, and the thickness of the connections between the arm and the pin are 0.25” thick. Approximating m_1 to about 3kg, and the calculating the contact surface area yields a net stress on the order of 100kPa, several orders of magnitude less than the yield stress of Al6061. For this reason, there would be very little concern for failure of this pivot mechanism at the surface contacts on the pin.

3.3.2 Spring

Ideally, the direction of the force vector from the weight of the fixture plate should be co-linear with the mechanical springs. For this reason, the spring method for decoupling the plate would only be implemented in the new orientation (i.e. with the fixture plate parallel to the ground as shown in Figure 10). One concern with this configuration was whether the springs would compress completely, or “bottom out”, because this would result in noisy data from a secondary shock. For this reason, some simple calculations were made in order to determine the order of magnitude of spring constant needed for this configuration.

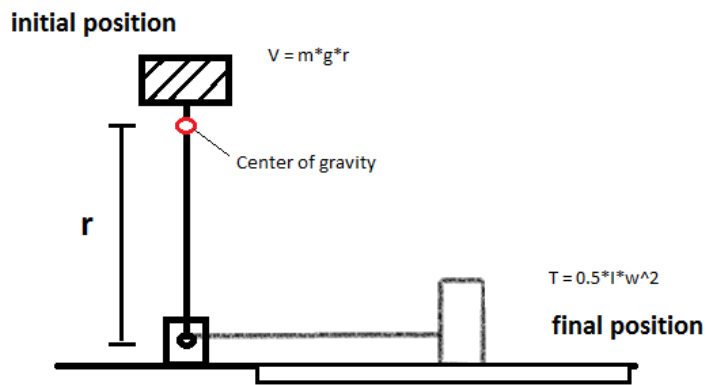

Figure 8: Sketch of the initial and final states of the hammer in the new configuration

Assuming the hammer is at an upright position, its potential energy is given by

$$V = m_1 * g * r \quad (4)$$

where m_1 is the combined mass of the hammer head and arm, and r is the length from the pivot point to the center of gravity of the hammer. Its kinetic energy at the moment the hammer arm is 90-degrees from the vertical position (the theoretical strike orientation of the hammer) is given by

$$T = 0.5 * I * w^2 \quad (5)$$

where I is the moment of inertia of the hammer, and w is its angular velocity. The moment of inertia of the hammer can be expressed as

$$I = m_1 * r^2 \quad (6)$$

Combining these equations, and converting w to linear velocity v yields the following relation

$$v_1 = \sqrt{2 * g * r} \quad (7)$$

where v is the linear velocity of the hammer head the instant it impacts the fixture plate. From conservation of linear momentum, we have the relation

$$m_1 * v_1 = m_2 * v_2 \quad (8)$$

where m_2 is the mass of the fixture plate, and v_2 is its subsequent linear velocity (assuming a perfectly rigid plate) as a result of the hammer impacting it. Plugging in our equation for v_1 , we obtain the relation

$$v_2 = (m_1/m_2) * \sqrt{2 * g * r} \quad (9)$$

It follows that the subsequent kinetic energy of the fixture plate after the moment of impact is expressed by

$$T = 0.5 * m_2 * v_2^2 \quad (10)$$

which, when substituting in our previous equation for v_2 , yields

$$T = (m_1^2/m_2) * g * r \quad (11)$$

This energy needs to be counteracted by four springs. The potential energy stored by these four springs can be expressed by

$$PE = 4 * 0.5 * k * x^2 \quad (12)$$

where k is the spring constant and x is the displacement of the spring. Note that there is already an initial displacement x_i of the springs due to the force imparted by the weight of the fixture plate. Hence, the true potential energy of the springs is given by

$$PE * = 2 * k(x + x_i)^2 \quad (13)$$

where x_i can be solved from balancing the force exerted by the springs and the weight of the fixture plate, yielding

$$x_i = m_2 g / 4k \quad (14)$$

It then follows that

$$(x + x_i)^2 = ((m_1^2)g * r) / (2 * k * (m^2)) \quad (15)$$

Plugging in for x_i , then solving the implicit equation numerically for x given various values of k on the order of 10^3 - 10^4 N/m yields a curve showing spring displacement vs. spring constant k . It can be seen that at these values of k , the displacement of the springs is on the order of 10 cm, a reasonable amount for the purposes of this project. This indicates that decoupling the fixture plate from the rest of the frame via springs is a method worth exploring.

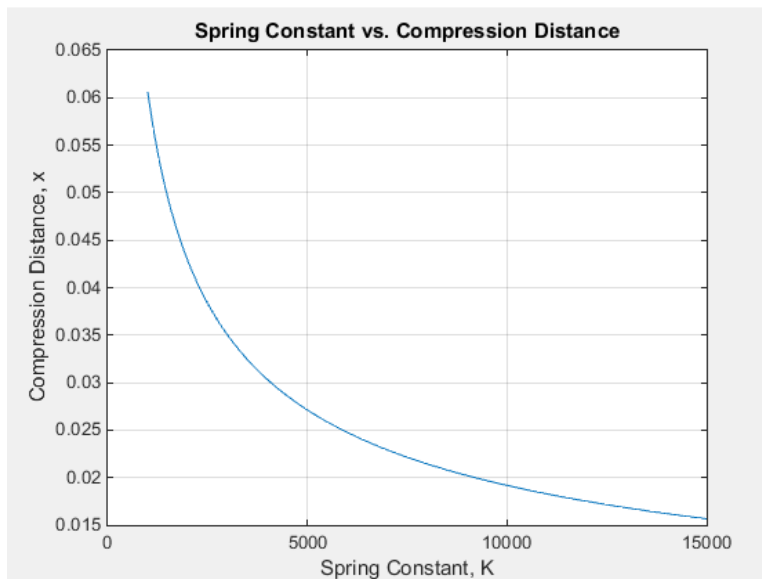

Figure 9- Graph of Spring Constant vs. Compression Distance

Figure 11 displays a curve generated using a simplified equation that does not include the initial compression felt on the springs by the plate. The significance of this is to understand how high of a spring constant is needed to limit the compression of the plate after the hammer strikes to a certain distance in meters. Equation 16 was used to plot this

$$x = \sqrt{\frac{m1^2 * g * r}{2 * m2 * k}} \quad (16)$$

3.3.3 Stabilization

In Table 3, three design options are ranked under four categories found to be the most important based on sponsor input. The rankings vary from 1-5, with 5 being the best and 1 being the worst. These ranks are specific to our budget and our time frame.

Table 3. Decision matrix to increase the frame's stability

	<i>Cost</i>	<i>Time to complete</i>	<i>Effectiveness</i>	<i>Applicability</i>	Total
Mounting frame to heavy plate	3	4	3	4	14
Mounting to floor	3	5	5	3	16
Redesigning frame	1	1	5	2	9

Mounting the existing frame to the floor is the design option that has the largest total, therefore it is the course of action that will be taken. It was the option that was favored by our faculty advisor, and should be more effective than any other option. Complications occur when finding a space and permission to do this. Ideally, if this possible, U-brackets will be used to directly bolt the frame to the ground.

If bolting to the ground is not an option, the four bottom legs of the frame will be disassembled from the horizontal connections and will be secured to a steel plate of specified dimensions by four 45 GD feet. These are pictured below in Figure 12.

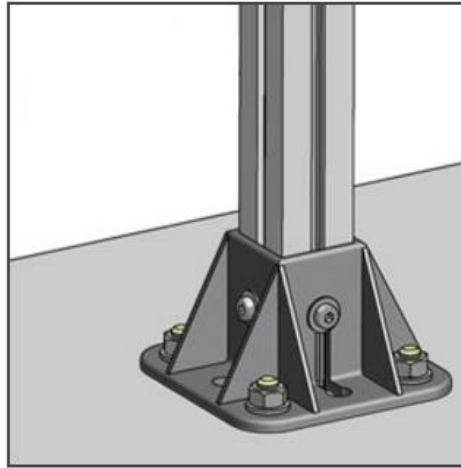

Figure 10. Foot 45 GD

The steel anchoring plate is meant for stabilization, so its nature of being a heavy weighted object is why steel was chosen in the first place. However, the plate cannot be so big and heavy that it cannot be transported. Also, this steel plate will need to be machined as each foot will need four threaded holes in order for them to be bolted down. A $\frac{3}{8}$ ” thick plate that is 41” by 41” weighs 178.8 lbs and is \$99.42 at discountsteel.com. If we decrease the thickness, the feet will not be as secure and the frame not as stable, however if we increase the thickness, then it may be too heavy to transport. This size optimizes both concerns.

It is important to note here that when transporting the test rig the frame can be easily disassembled from this anchoring plate to make transporting somewhat easier. With a weight of 178.8 lbs though, this is still not an easy or one person task.

3.4 Final Design Implementations

Of the above modular design concepts all have been narrowed to a final option and a few have been implemented. The design has been approached from the ground up beginning with stabilization. It was heavily stressed by our advisor that the device could not merely be weighted down, but instead must be physically anchored. As one might assume, it was not possible for us to anchor the device to the floor of the College of Engineering, but another option became available.

The device is now making use of a large and heavy instrumentation table which can be seen in Figure 13.



Figure 11 - Newport Series Optical Table

This table top weighs 528lbs and is decoupled from the legs of the table. The table top also has 1/4 - 20 holes spaced in a grid 1 inch apart. These holes were used to anchor the device to the table using cable straps and foam insulation. Along with anchoring, the pivot mechanism has been replaced. The proposed design of ball bearings has not been used because a simpler and nearly equally as effective option was found. This option was a dynamic pivot joint made for the 80/20 aluminum system which uses lubricated bronze bushings. This pivot has eliminated the unnecessary degrees of freedom and ensured the accuracy of the strike location of the device's hammer.

The remaining changes that need to be implemented include decoupling the plate and possibly using an electromagnetic quick release. It has been agreed upon by the group, our advisor and sponsor that the plate should be decoupled using the tethered method. This method better supports the weight of the device and is also less expensive. A new and smaller strike plate will be designed and ordered to fit this approach. Ordering a new plate allows for changes to be made such as reducing the hole spacing which allows for a smaller sacrificial plate while also allowing the original to be used if there is a mistake or the new design does not work for some reason. Both

Team 12

Development of Hammer Blow Test to Simulate Pyrotechnic Shock decoupling and the electromagnetic release mechanism will be pursued while initial baseline data is collected on the now stable device.

4. Project Management

4.1 Risk and Reliability Assessment

The full risk assessment is seen in Appendix 3. However, it is important to note its main points. It is expected that some machine work will need to be done, but whether or not the job is simple enough for a team member to complete it is still unknown. If a team member can machine any given part, all shop safety rules will be followed, including wearing personal protection equipment, always being alert, and of course only operating equipment that one is certified to use. Any given team member should not be working alone ever either. For the testing aspect of this project, hazards could definitely be seen when working with multiple heavy swinging hammers. It has been determined that warning when the hammer will be swinging will be given beforehand to allow anyone in proximity a chance to move out of the line of fire. Also, all handling of the hammer heads will be done so with care and full attention, and once again, team members will not work alone in this setting. If any injuries are to occur, the faculty advisor, Dr. Kumar, will be notified in addition to Dr. Gupta and Dr. Shih. Medical treatment will be obtained depending on the severity of the situation.

As for reliability an attempt was made to quantify any possible failure points, and their associated rate of failure. We examined the components individually and together as a whole and found seven points of concern. The most obvious possibility of failure comes from the point of impact (hammer to plate contact). The least obvious would likely be the pivot points for the quick release and the hammer arm. A failure mode effect analysis was performed on the points of concern and can be found below in table 4. Here, an attempt to quantify the possibility of component failure is tabulated for review. The team has realized the most likely source of failure is in the pivot rod for the hammer arm, and this can be combatted by both pre-test and post-test inspections as well as pre-test dynamics calculations.

Table 4 - FMEA Table for Reliability Analysis

Input	Failure Mode	Failure Effects	SE V	Possible Cause	OC C	Control	DE T	RP N	Action
Hammer	Fracture	Partial force generation/ Delay in testing	6	Inadequate Material	1	Pre/Post test inspection/ Material Selection	9	54	Replacement/ New Material
Hammer Arm	Bending/ Fracture	Partial force generation/ Delay in testing	6	Off Center	1	Pre/Post test inspection/ Material Selection	9	54	Replacement/ Larger Diameter
Arm Pivot	Bending/ Fracture	Delay in testing/ Skewed Results	6	Cyclical Fatigue	3	Pre/Post test inspection/ Material Selection	6	108	Replacement/ New Material
Quick Release	Premature or Failure to Release	No Results/ Injury if premature	5	Cyclical Fatigue	3	Pre/Post test inspection/ Material Selection	7	105	Replacement/ Redesign
Mount Size	Sliding/ Rolling	Partial force generation/ Damage to Components/ Injury	7	Incorrect Size	2	Pre/Post test inspection/ Material Selection	3	42	Modification/ Replacement
Fixture Plate	Bending/ Fracture	Skewed Results/ Delay in testing/ Damage to accelerometer	7	Off Center	1	Pre/Post test inspection/ Material Selection	4	28	Replacement/ New Material/ Size

4.2 Procurement

After receiving a DAQ card from Dr. Kumar, the team can now start collecting useful data to study in order to see what other changes need to be made to the test device. A new strike plate and an electromagnet to be used for the release mechanism will be the next order.

4.3 Resource Allocation

The team will work collectively on all deliverables and split up the writing as needed per assignment. For the immediate future, there will be two sub-groups within the team. One will focus on testing and gathering that initial baseline data. This will include Max and Luis. The second group, consisting of Sarah, Justin, and Tiffany will focus on learning the modeling and software aspect of this project. This sub-grouping was suggested by Harris, and will hopefully maximize time. Of course, all team members are expected to contribute where they are needed. When reaching the point of finalizing the design changes and ordering parts, Justin, as financial advisor will take charge there. Max will continue to be the main contributor to the website designing.

An updated Gantt chart and task breakdown for the Spring semester can be seen in Appendix A. The first part of the semester was not as productive as it could have been, but the goal is to make up for that time lost and stay on track in the next few weeks. The next steps in this process are to start collecting data and see how close we are to achieving the first goal of obtaining repeatable results. Also, the team will be ordering the new strike plate, an electromagnet, and a DAQ system that can be used not only for the remaining time of this project after returning the borrowed system from Dr. Kumar, but for future senior design teams.

5. Environmental and Safety Issues and Ethics

In terms of environmental safety, this project does not involve anything that could be damaging to the environment during testing or afterwards in waste. The main concern is with safety as this project deals with various heavy weights acting as swinging hammers. Injury could easily be caused due to a lack of attention. Additionally, the noise created by the impact could be considered a safety concern. Proper precautions will be taken to avoid injuries, these will include things such as audible alerts before testing and any hammer operation. It is also important that all members and operators understand the gravity of the situation. Other steps will be taken to prevent non team members from having access to the equipment so that only those with understanding and experience with the project will have access to operation.

6. Results and Conclusion

In retrospect, our team greatly underestimated the scope and complexity of this project. As a result, we have been set back several weeks. With that being said we have been working hard to make up time and stay on schedule. Mr. Wells had set a goal to have baseline data by the end of the fall semester. Our recent acquirement of a DAQ system and the stabilization changes that were implemented allows us to start baseline data collection over the break or in the first weeks of spring semester. As we collect baseline data part of the team's time and resources will be spent on decoupling the plate from the frame and researching electromagnetic release mechanisms.

Some major challenges the team will face in the spring will be growing accustomed to data acquisition and signal processing, as well as efficient modeling using computer software to generate SRS curves from raw testing data. In order to help ease this learning curve, extensive communication with faculty advisor Dr. Kumar, Harris sponsors, and graduate students will be sought. Once the test rig is built, simple testing will be conducted first to confirm predictions based on modeling and establish a good understanding of the test fixture's response to shock impulses. From there, further testing of the effects of changing isolated variables can be completed and the results documented.

References

1. "Pyro Shock Testing." *Pyroshock Testing Simulation & Techniques*. National Technical Systems, Inc., 2015. Web. 27 Oct. 2015.
<https://www.nts.com/services/dynamics/shock/pyro_shock>.
2. DeMartino, Charles, Chad Harrell, Chase Mitchell, and Nathan Crisler. *Pyrotechnic Shock Test Development Midterm Report*. Senior Design Team 15. 31 Oct. 2014. Web. 28 Oct. 2015.
<http://eng.fsu.edu/me/senior_design/2015/team15/Team15_Midterm_I.pdf>.
3. Wells, Robert. "University Capstone: Development of Hammer Blow Test Device to Simulate Pyrotechnic Shock (Second Year Project)." 14 Aug. 2015.

Appendix A- Gantt Chart and Task List

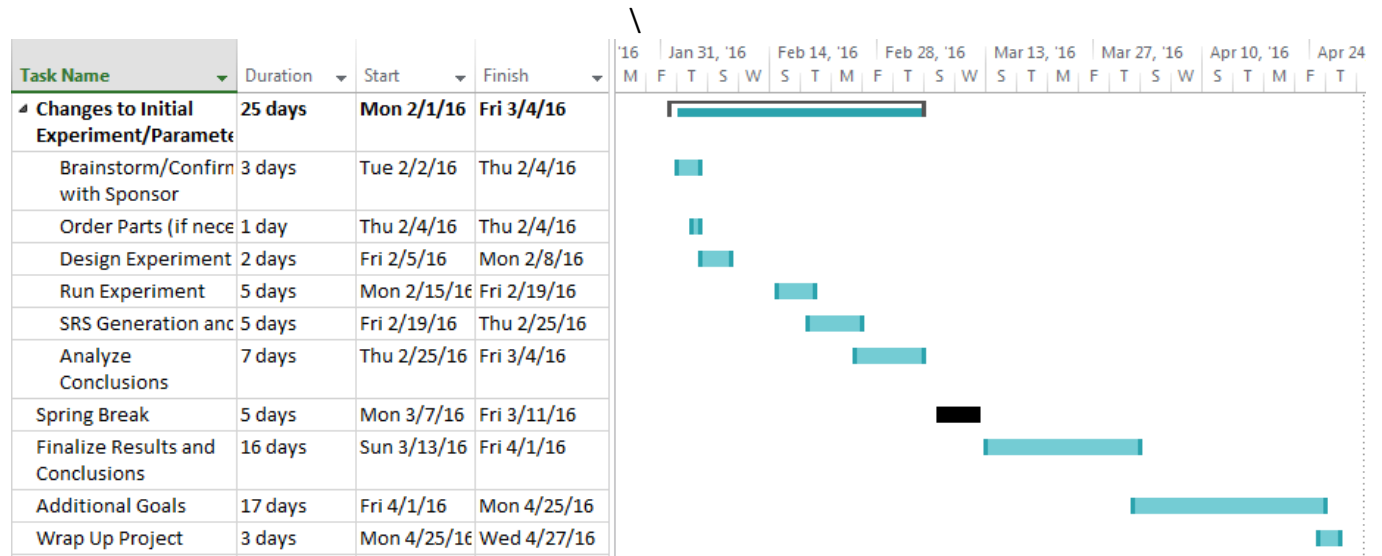
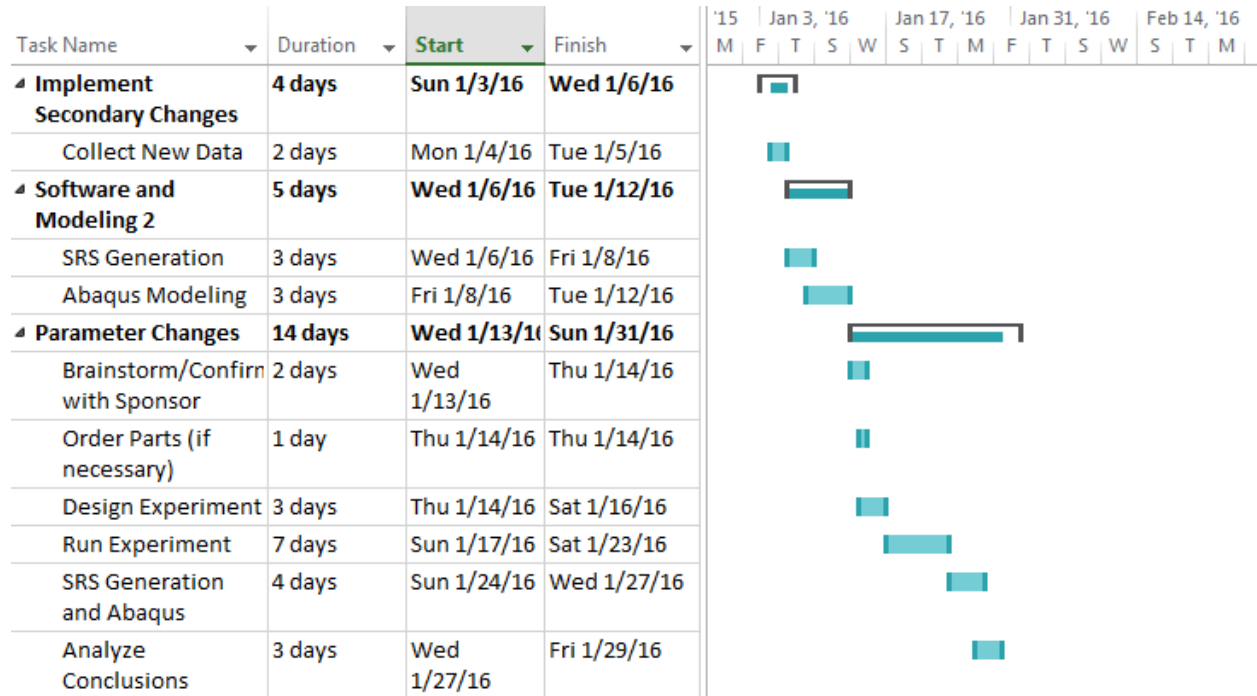

Appendix 2- CAD Drawings

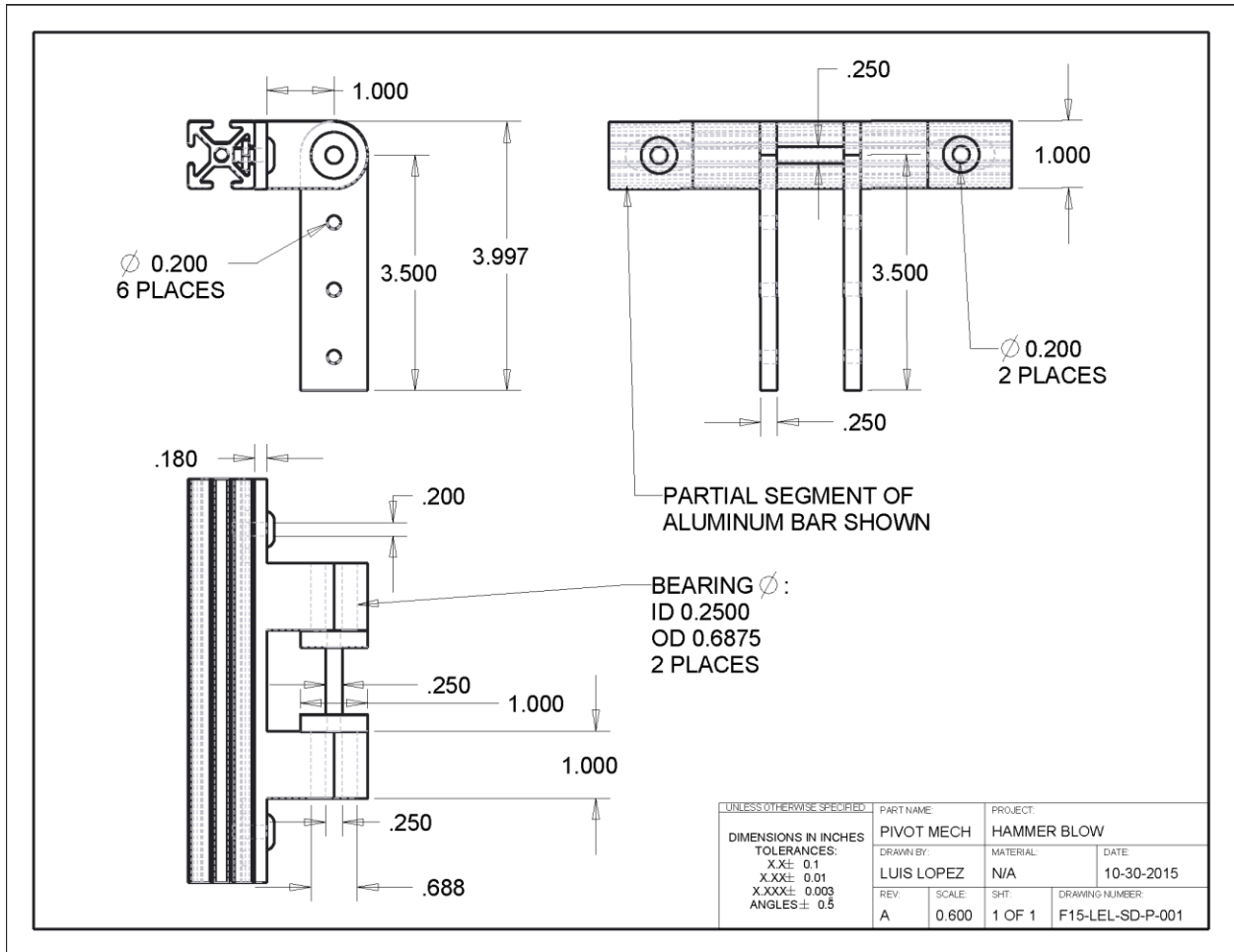

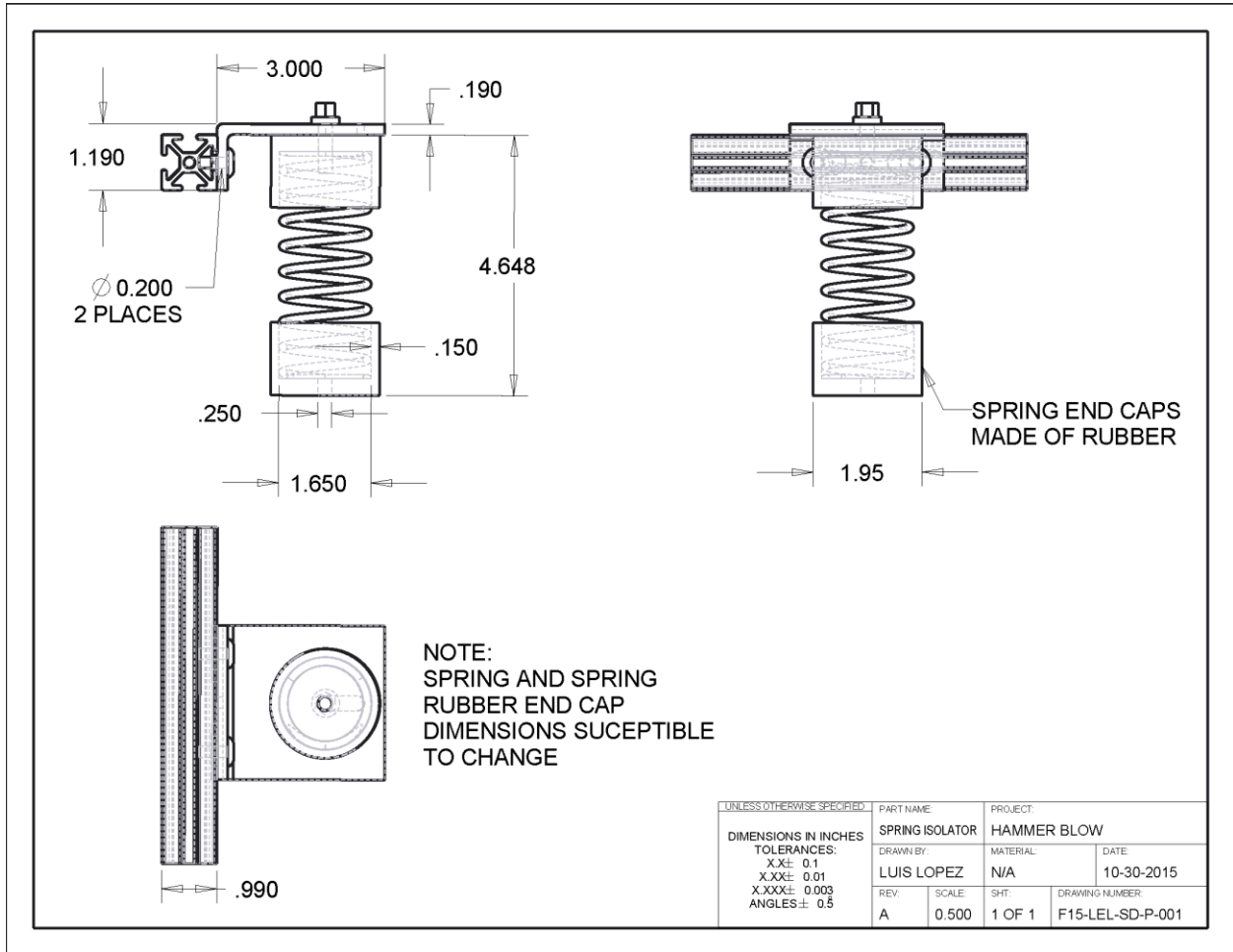

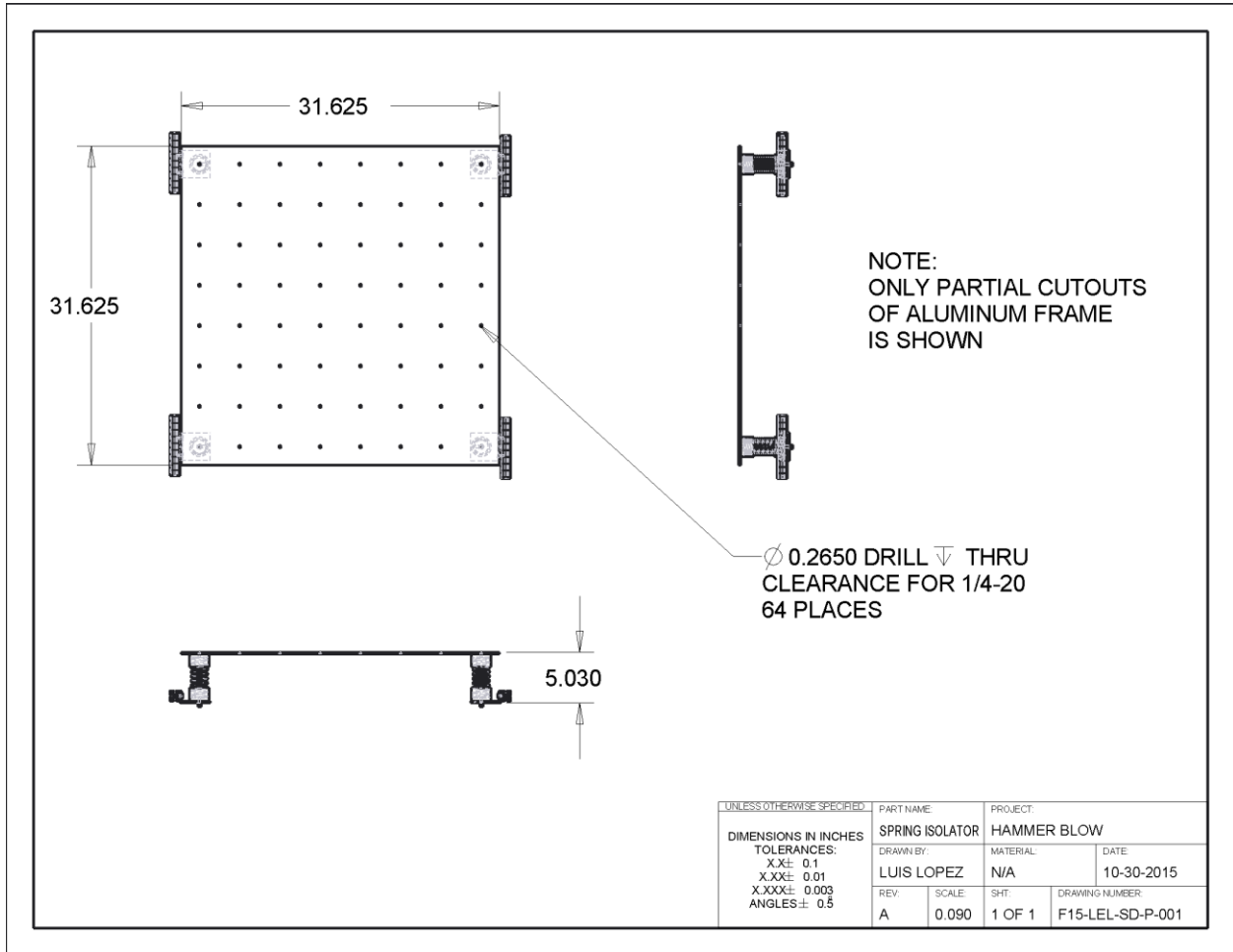

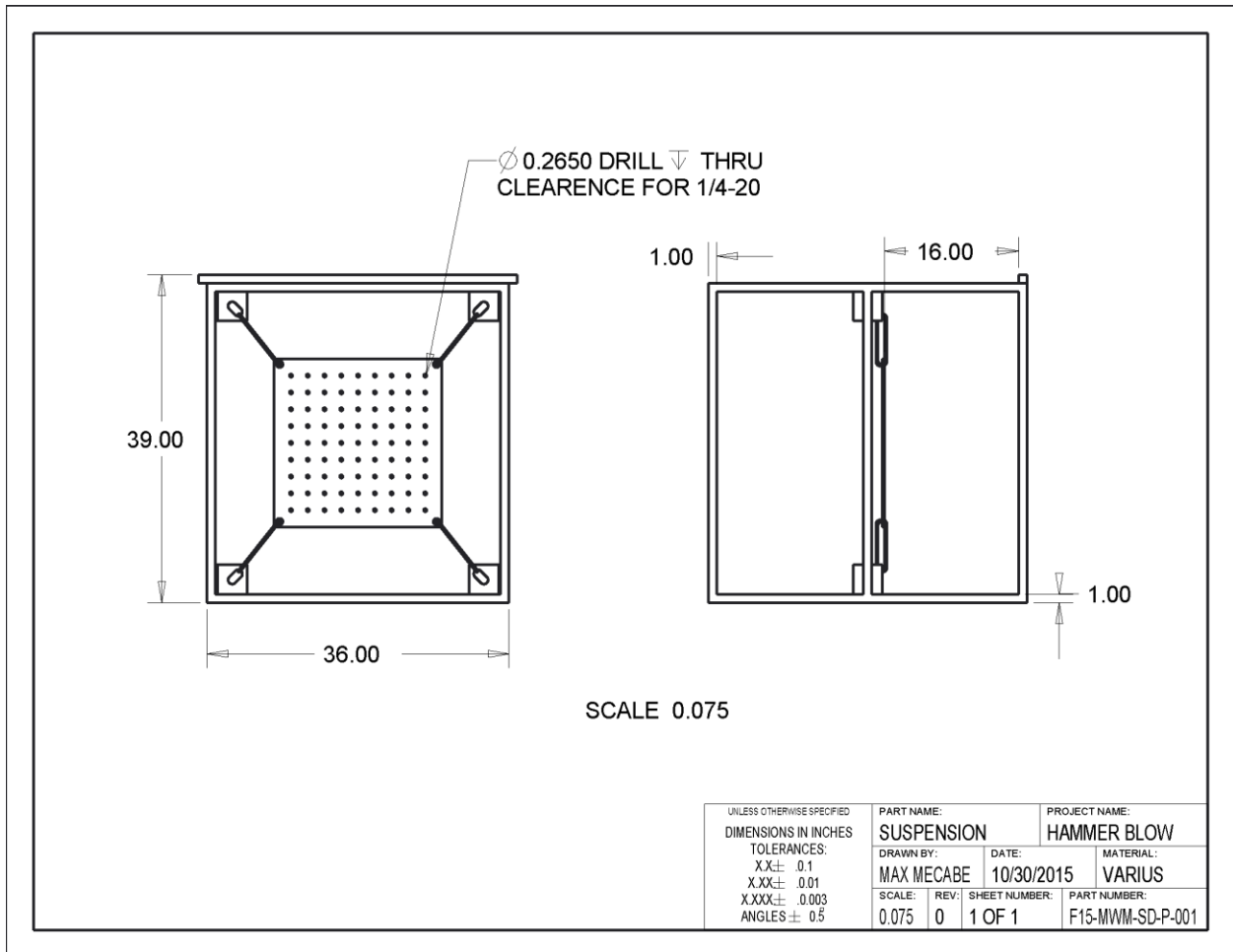

Appendix 3- Risk Assessment

Risk Assessment Safety Plan

Project information:		
Development of Hammer Blow Device to Simulate Pyrotechnic Shock		10/30/15
Name of Project		Date of submission
Team Member	Phone Number	e-mail
Luis Lopez	786-510-2619	Lel12b@my.fsu.edu
Max Mecabe	904-654-3749	Mwm12@my.fsu.edu
Tiffany Shaw	941-780-5707	Tas12e@my.fsu.edu
Justin Vigo	813-416-2259	Jlv11b@my.fsu.edu
Sarah Wyper	813-766-6232	Saw10f@my.fsu.edu
Faculty mentor	Phone Number	e-mail
Dr. Kumar	850-645-0149	rkumar@fsu.edu

I. Project description:

This project is sponsored by Harris Corporation and is a continuation from Senior Design Team 15 last year. It has been determined that a feasible way to test the effects of pyrotechnic shock involves simulating the shock with a hammer blow device and using the resulting data to generate SRS curves. The test device was designed and built last year, but can use improvements in terms of repeatability, decoupling of the plates, anchoring of the frame, and increasing the strike force. The software created last year does work, but the intent is to further refine it and optimize the modeling approach.

II. Describe the steps for your project:

After gathering background information and studying the current test device, design concepts have been brainstormed and researched to improve a few components of the test device. After choosing the new design, CAD drawings will be further refined and parts will be ordered. Once the parts arrive, machine work may need to be done, and the new device will be assembled in order to start running experiments. Concurrently, the software used last year will be studied in order to learn what can be done to optimize it. Additionally, the hope is to be able to reduce the set of parameters that are being studied from the test device as well.

III. Given that many accidents result from an unexpected reaction or event, go back through the steps of the project and imagine what could go wrong to make what seems to be a safe and well-regulated process turn into one that could result in an accident. (See examples)

Without taking caution, there is definitely a lot that could go wrong in this project. For one, accidents involving misuse, complacency, or failing equipment in the machine shop could result in personal harm to the team members or anyone else in the shop at the same time. When operating and running experiments on the test device, team members need to remember that they are swinging various heavy hammers that could be easily harm a person if hit or if not paying attention. Also, material selection becomes very important to make sure the frame and other supporting features do not fail under the load and number of tests run. When working with the electronic components, like the accelerometer and BNC board, it is obviously important to not damage this equipment as it is very sensitive and expensive. Team members should always know exactly what they are connecting when working this equipment and should not have any food or water in this workspace.

IV. Perform online research to identify any accidents that have occurred using your materials, equipment or process. State how you could avoid having this hazardous situation arise in your project.

Obviously working in a machine shop can pose many hazards. Stories of injuries and accidents are very easy to find, like how a Yale student was killed when her hair got caught in a lathe or fingers coming too close to a bandsaw. When working in the shop, the team will be extremely cautious and keep an eye on one another. No one will work alone and personal protective equipment will be worn at all times. Specific examples for working with a device similar to what is being modified this year were difficult to find, but it is easy to imagine accidents occurring by not carrying the hammer carefully or not paying attention when it is swinging and tests are being run. It is necessary to warn everyone in proximity beforehand when the hammer will be swinging and to make any adjustments to the test rig with full attention and care, so fingers do not get crushed, toes do not break, or any other injuries occur.

V. For each identified hazard or "what if" situation noted above, describe one or more measures that will be taken to mitigate the hazard. (See examples of engineering controls, administrative controls, special work practices and PPE).

For working in the machine shop, the first form of safety is ensuring that all equipment is only operated if the user/team member knows exactly what they are doing and how to run that machine. Additionally, gloves, goggles, and all other PPE will be worn at all times. No one will work alone either to ensure there is an extra set of eyes looking for possible hazards. When building and running the test device, communication will be key. Advanced warning will always be given before swinging the hammer. Also, no team member will run tests by themselves. All materials and tools used during building and testing will be handled with care and full attention.

VI. Rewrite the project steps to include all safety measures taken for each step or combination of steps. Be specific (don't just state "be careful").

Safety concerns really start after the researching, brainstorming, and design phase. After the parts arrive, and it has been determined that machine work needs to be done, the team will set up a specific time to go in if the work can be done directly by us. If this is the case, no one will go in alone and PPE will be worn. Members will be fully alert and fully understand what they are doing and how to operate the equipment. If the work cannot be done directly by a team member, work orders will be put in to have someone who works in the shop complete what is necessary. For assembly of the device, again no team member will work alone and will need to be fully alert when using tools. Extra delicacy will be taken when handling the heavy hammer heads. All tools will be used properly, and if a team member does not know how to do so, someone else will need to use that tool. Once assembled, tests and experiments can start being run, and again no team member will do so alone. Everyone within the same room of the test device will be given advanced warning as to when the test will be running so as to clear the space in case material failure happens or the hammer detaches somehow. Constant communication will need to occur when tests are occurring.

VII. Thinking about the accidents that have occurred or that you have identified as a risk, describe emergency response procedures to use.

If accidents are to occur in the machine shop, all equipment will be shut down immediately and the TA's or shop worker will be told of the incident. Contacting the COE faculty emergency contacts will also happen. Emergency procedures from the lab training and safety manuals, used in the shop and from earlier in this class will be followed with the appropriate responses, depending on the severity of the situation. For accidents occurring during testing, all testing will immediately be stopped. If there are serious injuries, the COE faculty emergency contacts will be notified and 911 will be called. The injured person will receive the necessary medical treatment.

VIII. List emergency response contact information:

- Call 911 for injuries, fires or other emergency situations
- Call your department representative to report a facility concern

Name	Phone Number	Faculty or other COE emergency contact	Phone Number
		Dr. Gupta	850-410-6201
		Dr. Shih	850-410-6321
		Dr. Kumar	850-645-0149

IX. Safety review signatures

- Faculty Review update (required for project changes and as specified by faculty mentor)
- Updated safety reviews should occur for the following reasons:
 1. Faculty requires second review by this date:
 2. Faculty requires discussion and possibly a new safety review BEFORE proceeding with step(s)
 3. An accident or unexpected event has occurred (these must be reported to the faculty, who will decide if a new safety review should be performed.
 4. Changes have been made to the project.

Team Member	Date	Faculty mentor	Date
<i>[Signature]</i>	10/29/15	<i>Rajan Kumar</i>	10/29/15
<i>[Signature]</i>	10/29/15		
<i>[Signature]</i>	10/29/15		
<i>[Signature]</i>	10/29/15		

Report all accidents and near misses to faculty mentor.