

# DELIVERABLE IV: MIDTERM I REPORT

EML4550C – Senior Design Fall 2015

TEAM 17 - “DOG GROOMING TOOL”



Sponsors - Bill Bilbow, Todd Hopwood

Team Advisor – Dr. Simone Hruda

Course Advisor – Dr. Nikhil Gupta, Dr. Shih

Submission Date: 10-30-2015

Submitted To: Dr. Nikhil Gupta

Authors: Justin Proctor (*Team Leader*)

Jordan Chupp (*Secretary*)

Dennis Pugh (*Treasurer*)

Roy Mason (*Web Designer*)

# Table of Contents

Abstract .....	iii
1. Introduction .....	1
2. Project Definition .....	1
2.1. Needs Statement .....	1
2.2. Goal Statement and Objectives .....	1
2.3. Constraints .....	2
3. Design Analysis .....	2
3.1. Design Specifications .....	2
3.2. Performance Specifications .....	3
3.3. House of Quality .....	5
3.4 Concept Design One .....	6
3.5 Concept Design Two .....	7
3.6 Design Selection .....	10
4. Project Scheduling .....	11
4.1. Methodology .....	11
4.2. Work Breakdown Structure .....	12
4.3. Gantt Chart and Critical Path .....	12
4.4. Project Task List .....	14
5. Results .....	14
5.1 Risk Assessment .....	14
5.2 Initial Testing .....	15
6. Conclusion .....	16
7. Team 17 Biography .....	16
8. Acknowledgments .....	17
9. References .....	18
Appendix .....	19
A1: Risk Assessment Safety Plan (See Attachment) .....	19

## Table of Figures

<b>Figure 1: House of Quality .....</b>	<b>5</b>
<b>Figure 2: Concept Design One .....</b>	<b>6</b>
<b>Figure 3: Concept Design Two Brush Head Front View .....</b>	<b>8</b>
<b>Figure 4: Concept Design Two Brush Head Side View.....</b>	<b>9</b>
<b>Figure 5: Concept Design Two Brush Handle: Front View .....</b>	<b>9</b>
<b>Figure 6: Concept Design Two Brush Head Bottom View.....</b>	<b>10</b>
<b>Figure 7: Work Breakdown Structure Diagram .....</b>	<b>12</b>
<b>Figure 8: Revised Gantt Chart.....</b>	<b>13</b>

## **Abstract**

This is the design report deliverable for the Midterm of the Dog Grooming Tool project. In this report Team 17 restates the project definition through the reiterations of the need statement, the goal and objective statement, and any front-end constraints imposing this project. As a part of the project definition, this report also includes a QFD diagram, which reflects upon the analysis conducted in obtaining the voice of the customer as well as the characteristics of competitor products. Planning phase of this project is represented in this report through the work breakdown structure, which is presented in the form of a Gantt chart and a Critical Path Method diagram. This midterm report provides the design analysis, comprising of the design specifications and drawings of the models for the conceptual designs that are being developed by Team 17. Lastly this report also provides the results of the risk assessment and its associated contingency plan, as well as the results of the test of the proof of concept that was conducted.

# 1. Introduction

Team 17 has been selected to provide a solution for the unpleasant grooming experiences of dogs and their caregivers, through the design and construction of a tool, which will allow a dog's coat hairs to be detangled and ordered using a process that is non-stressing for the groomer, and pleasant for the dog.

So far in the initially stages of this design project, Team 17 knows and understands that the current brushes that are being used to detangle and de-mat dog coats function inadequately to the expectations of their users. Team 17 also understands that while there is a market for their desired product, a detailed planning process, as well as a thorough research and prototyping phase, are essential for a successfully designed product that meets the objectives, and accomplishes the goal. Team 17 has implemented several methods as ways to appropriately plan for the project ahead. These methods include the construction of a Gantt chart, which provides the project's critical path methods, allowing the team to stay on top of the progress of current tasks and to prepare for upcoming ones. In the development of the design prototype there are a number of technical questions that must be both asked and answered that allow for the team to take the characteristics of which it is essential for the product to consist. The research phase helps provide answers to the design questions, which in turn provides the prototype design phase with the opportunity to be effective and resourcefully efficient

## 2. Project Definition

### 2.1. Needs Statement

For this project we have two sponsors, Todd Hopwood and William M. Billbow. The problem presented to Team 17 is that dogs of all hair qualities, textures, and lengths, experience matting and tangling in their coats. This matting makes it tough to groom the dog when trying to complete small tasks, such as brushing a dog's hair. This problem is seen in many different types of dogs with different hair lengths.

*“De-matting a dog's hair can be an unpleasant experience for both the dog and the groomer, especially if the matting has advanced and is deep in the hair or fur. To de-matt or de-tangle, it can be very time consuming and uncomfortable, if not painful.”*

### 2.2. Goal Statement and Objectives

**“Design and develop a grooming tool that untangles matted hair.”**

The objectives of this project are:

- Design a hand held dog grooming tool for use by consumers, groomers, and dog rescues.

- Successfully untangle hair without harming animal
- Develop a hand-held rotary pet groomer that provides for a stress-free experience for both the dog (or other animal) and the groomer

### **2.3. Constraints**

The constraints of this project are:

- The tool must be hand-held and ergonomically friendly
- The tool must have a low RPM to keep quiet
- The tool must be easy to clean and sterilize
- The battery should last 2 hours at 50% duty cycle
- The total weight must be at 1 pound or under

## **3. Design Analysis**

### **3.1. Design Specifications**

In order to design a tool that will meet the specified goals, various specifications are required. Table 1 below lists the design specifications, but they are broken down here with descriptions starting with the overall design. The whole tool must be lightweight, which will require it to be one pound or less. Obviously the design will need to be appealing in order to get customers to buy the product when it hits the market. The design of the tool itself can be broken down into three major components which are the handle, the internal electronics such as the motor, and the rotary head.

Starting with the handle, it must be hand held and ergonomic, meaning the device must be comfortable to the customer's hand and not much force be needed to operate the device. The idea is to take away as much stress as possible and by providing a customer friendly tool, much stress will be levitated.

Moving to the inside of the tool, the battery will need to have a 2 hour duty with an 8 hour standby. Along with these specifications, the battery must be designed to be replaced quickly. The more stressful it is to replace a battery the less likely someone is to buy the product. Also, the power must have 120V of ac alternate. These specifications are early on and are subject to change if needed.

Finally, there are some rotary head specifications. These include removable, single speed, bi-directional, low speed, small diameter, and bristles. The removable idea is key, because if one head is ruined, instead of replacing the whole tool, one could just replace the head. Also, taking the head off the tool provides a much easier availability to clean the head. The device must be single speed so that a careful low speed near 60 revolutions per second would not harm the animal.

The bi-directional does not mean go both directions in this case, it refers to the head being able to be put on in the opposite direction so that no matter which hand is dominant the customer has the same experience. Lastly, the head specifications include being around 1.5 inches in diameter, as to not be too bulky, and to have bristles of some kind that are not corrosive and easily breakable. These bristles are not required to be of a certain material. Many different types will be thought of and the type that is most successful when dealing with efficiency and harmless to the animal will be chosen.

**Table 1: Design Specifications**

<b>Item</b>	<b>Specification</b>
<b>Mobility</b>	Hand-held, ergonomic
<b>Power Source</b>	<ol style="list-style-type: none"> <li>1. Battery, 2 hr duty, 8 hr standby, with quick replacement</li> <li>2. 120V ac alternate</li> </ol>
<b>Weight (max)</b>	1 lb
<b>Rotary head</b>	<ul style="list-style-type: none"> <li>• Removable / replaceable</li> <li>• Single speed</li> <li>• Bi-directional</li> <li>• 40-100 rpm (Final speed determined experimentally)</li> <li>• Diameter: ~1.5"</li> <li>• Detangling elements/bristles: Stainless spring steel or similar (not subject to breakage, corrosion or harm to pet)</li> </ul>

### **3.2. Performance Specifications**

When designing this dog-grooming brush there are many performance specs that have to be taken into account. The performance specifications will define the desired functionality of the product when being used. With the understanding that dog groomers, dog rescue workers, and personal dog owners will be using this product, it is essential that the performance of this dog-grooming brush meet the needs and expectations of every consumer.

Some of the main performance specifications that this product must meet are that it must be able to detangle and de-mat any type texture or length of dog. From talking with many dog groomers, rescuers and dog owners, it is very apparent that detangling a dog's matted hair is very frustrating. It is said that using a conventional dog grooming brush is very time consuming, which is why we are creating a rotary style grooming tool. The brush must be electric powered device that does the de-matting and detangling work for the user. The brush must reduce the time it takes to de-matt a dogs coat significantly enough to make the use of Team 17's product worthwhile to customers.

Dog groomers and owners claim that using a conventional dog grooming tools create a lot of stress on the hands and arms of the groomer. The electric functioning of the brush must perform in a manner that reduces the wear and tear on the user, and eliminates the stress that dogs experience when the groomed manually. Team 17 has to make the tool more ergonomic to appeal to the comfort of the person using the brush. By creating an enjoyable experience with a simple task of grooming for the dog and its groomer, Team 17 can build brand trust and healthy consumer producer relationship.

The brush design must perform as quietly as possible, and output enough work to be effective in its grooming task while not harming any dog during the process.



### 3.3. House of Quality

(+) – Positive Correlation  
 (-) – Negative Correlation

◇ - Strong Interrelationship  
 □ - Medium Interrelationship  
 ○ - Weak Interrelationship

Rankings are on a scale of 5 to 1 with 5 being the most important

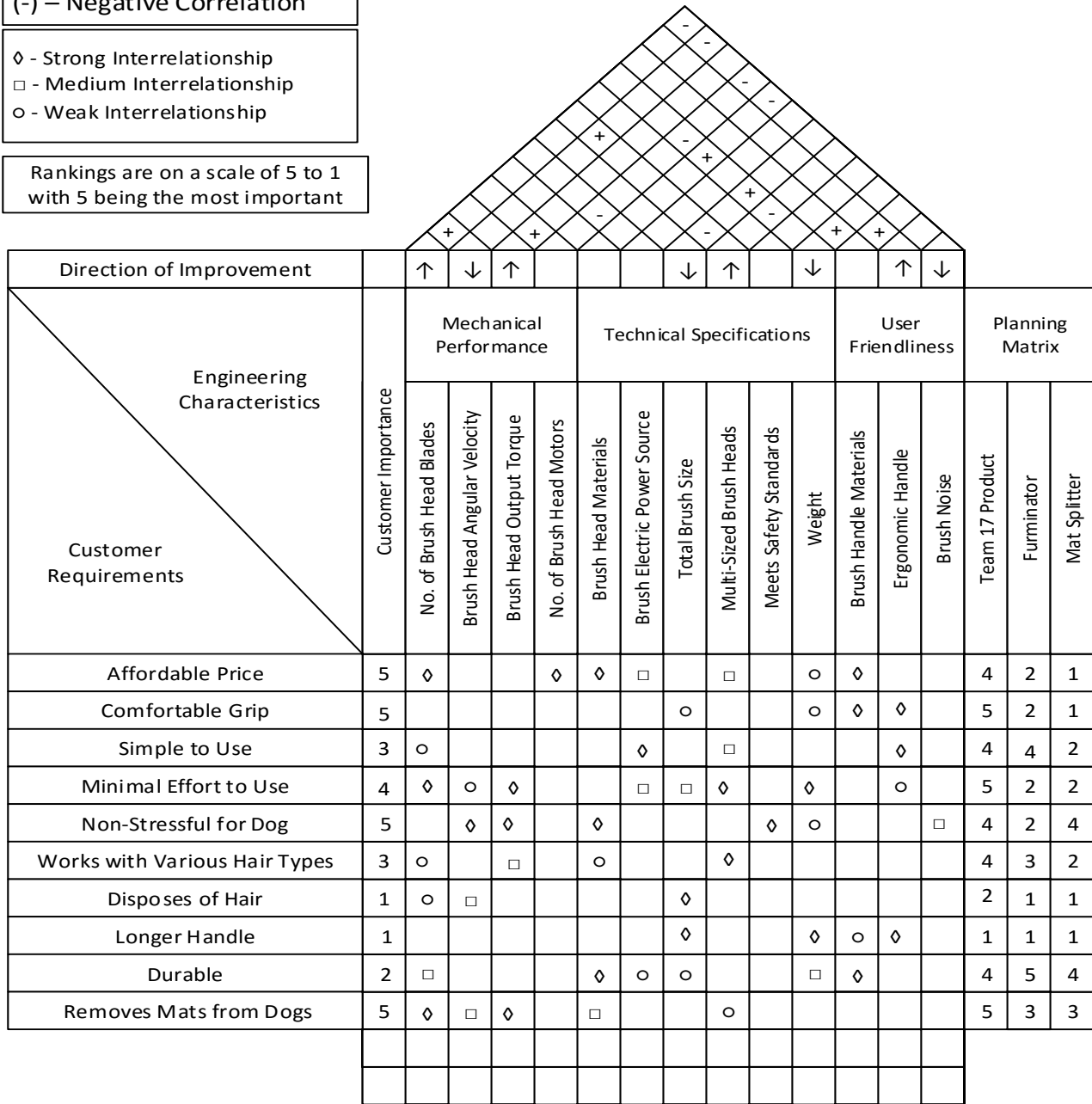

Figure 1: House of Quality

Figure 1 shown above is the House of Quality for Team 17. This diagram was constructed based on results from surveys and questionnaires that were conducted in order to define the voice of the customer. The house of quality was used to form relationships between the desires of the target market and engineering characteristics of the dog grooming tool. The engineering

characteristics are grouped under the categories of the tool's mechanical performance, technical specifications, and the user friendliness. All the categories except for the user friendliness are quantitative categories, which require the application of mathematical calculations and engineering principles. The user friendliness is a qualitative measurement and will be in direct relation to the voice of the customer. The roof matrix interrelates the engineering characteristics with each other define those that have strong, medium, and weak correlations. Finally the customer importance ranks the customer requirements on a 1-5 scale, with 5 being most important and 1 being the least. The planning matrix is similar to the customer importance as it likewise ranks the importance of the same customer requirements for team 17 and the designs of the leading competing devices

### 3.4 Concept Design One

Since the initial goal of this project was to make a simple, hand held product, design one focuses on these qualities and attempts to be a product that will appeal to multiple audiences. This as seen in figure 2, below, this design is as simple as possible while meeting all of the project constraints set by the group and sponsors. It has a very simple handle with a motor driven brush head.

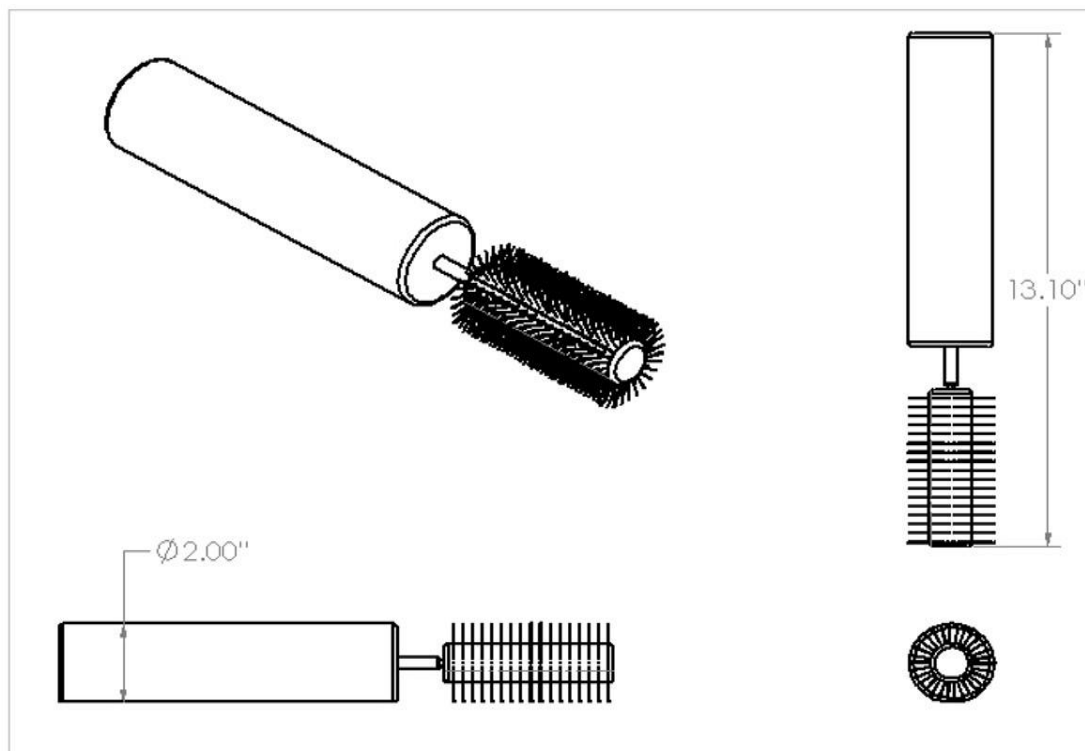

Figure 2: Concept Design One

Design one, or the hairbrush style, is designed to be familiar looking to the general public. This familiarity should help when introducing the product to potential customers. Not only is the handle

oriented to make use very natural, the steel wire bristles used in the brush head should be able to easily pull matts out of thick hair, with nothing more than normal brushing movements.

While design one is designed to very simple to use, it does have some drawbacks. The number one concern, as with any project, is safety. For this product to be sold commercially, safety must be a major design factor. To ensure no harm will come to the animal being groomed, it may be necessary to install guarding or bumpers around the brush head. There is also a chance for longer hair to become tangled around the barrel of the brush. This can be prevented by keeping the barrel sufficiently large so that even the longest of hair cannot fully wrap around it.

Design one also has drawbacks in terms of ergonomics. Although the brush was designed to be simple to operate, it does lack some key features that would make it easier to use for some users. Most notably, it lacks ambidexterity. Due to the rotation of the brush head, it would not be possible for left handed users to use the brush as comfortably. In order to solve this, the motor would need to have the ability to run in the reverse direction. While this is not a terribly complicated feature to add, it still requires more weight and planning to include. Table 1, below, includes a list of the pros and cons for this design.

**Table 2: Pros and Cons of Concept Design One**

<b>Pros</b>	<b>Cons</b>
Simple Handle Design	Lacks Ambidexterity
Low Cost to Manufacture	Requires Motor Reverser
Easily Swap Brush Heads	Difficulty Assembling Wire Brush Head

### ***3.5 Concept Design Two***

The second concept design that Team 17 developed incorporates the familiar style that is commonly seen in a 2” paint brush. The design consists of an ergonomically shaped handle that will be designed to contour to finger placement as shown in Figure 5. Concept design two’s handle will require that the user hold the handle in a vertical orientation shown below in Figure 5 versus the horizontal hand placement that concept design one requires in Figure 2. Based on research of grooming techniques it is understood that a vertical brushing motion will cause muscle fatigue more quickly than the horizontal motion. However, due to the fact that the brush will be motorized, the energy normally exerted by the user during repetitive brush strokes will be unnecessary. The brush head design concept shown below in Figures 3 and 4 was initially set to be cylindrical, having 8 inches in length and 4 inches in diameter. The design goal behind the 8 inch long brush head was that a longer brush head would cover as much dog hair surface as possible in order to limit the amount of time it takes to groom the dog. As far as the mechanical features of the brush tool in its entirety, they will be determined and chosen after further component and motor research and analysis are conducted. Table 3 below indicates the initial pros and cons that are associated with concept design two. One benefits that concept design two provides is the ergonomic handle. The fact that there does not need to be a reversible motor for the brush head to rotate for the use of left handed and right handed users is desired. Another benefit is the fact that this concept is

designed to keep all motors and electronics in the handle, allowing the brush head to be as simple in design as possible, making it cheap to replace and interchange. Drawbacks of this design are that the open spinning brush head could pose a danger to users who are ignorant or careless, and that it is currently unknown as to whether this design will be the best option in housing all essential components.

**Table 3: Pros and Cons of Concept Design Two**

<b>Pros</b>	<b>Cons</b>
Ergonomic Handle Design	Could be complex to fabricate
Provides for ambidexterity	Open spinning could be hazardous
Easily Swap Brush Heads	Unknown whether all necessary components can be housed

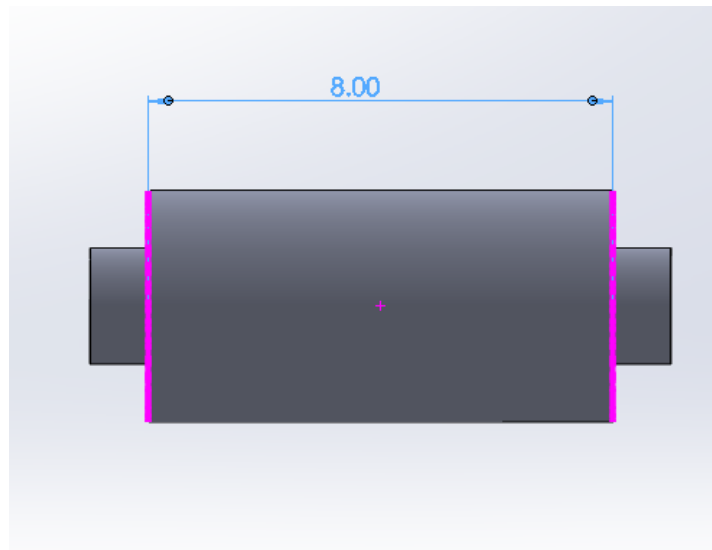

*Figure 3: Concept Design Two Brush Head Front View*

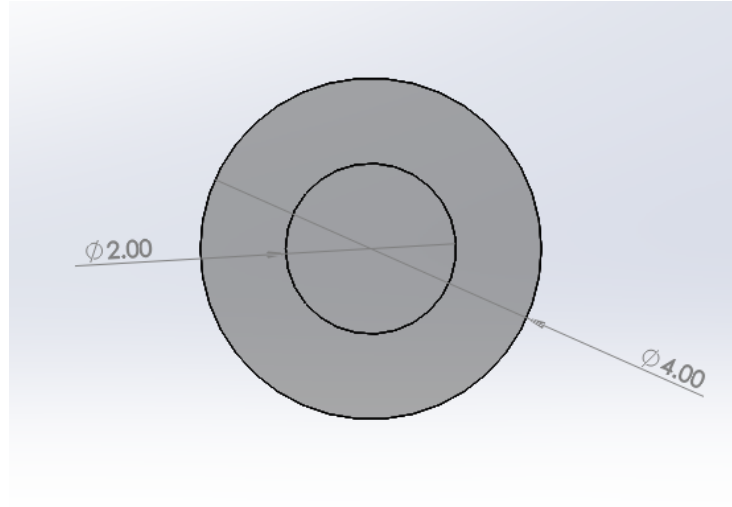

Figure 4: Concept Design Two Brush Head Side View

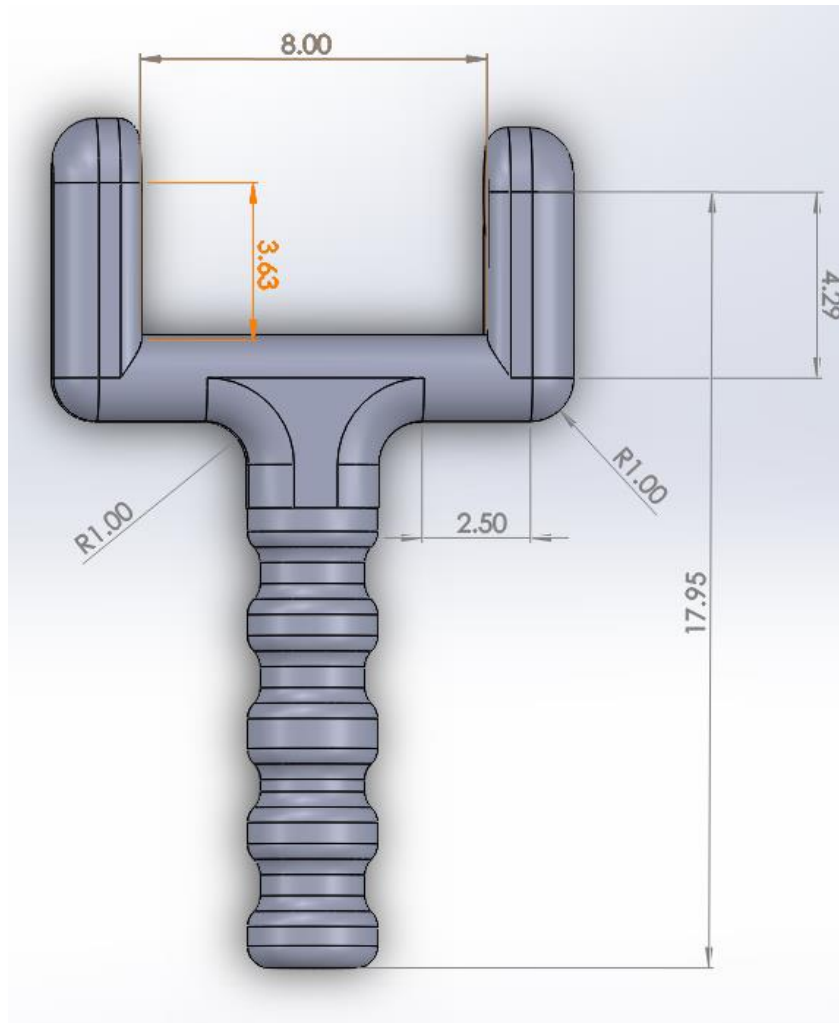

Figure 5: Concept Design Two Brush Handle: Front View

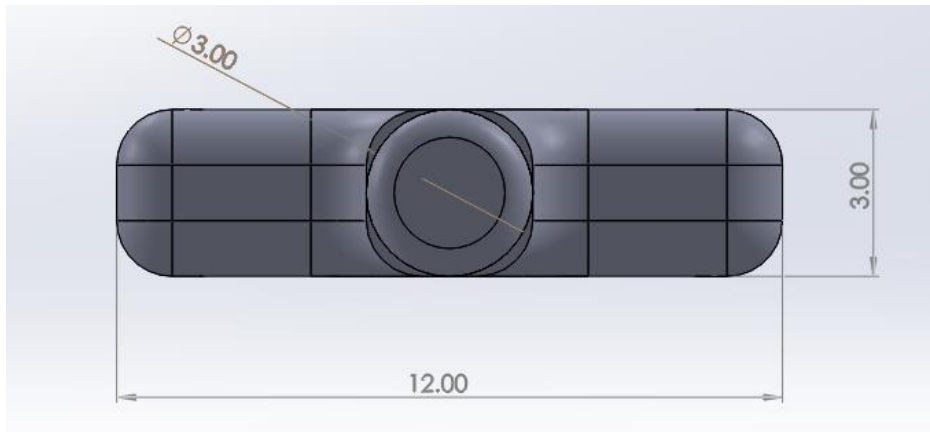

Figure 6: Concept Design Two Brush Head Bottom View

### 3.6 Design Selection

Table 4 below contains the decision matrix that was developed based on the design. The data listed in the decision matrix are based just on aesthetic analysis of both designs. As the design phase progresses and the research phase concludes. The final decision matrix will be much more complex as it will not be used to select specific designs but it will be used to decide on the selection of numerous components. The decision matrix of Table 4 indicates that concept two is more ergonomic due to its handle that contours to finger placement. Concept one is shown to be more cost efficient, because of Concept Two's complex handle design, it may be expensive to fabricate such a prototype. The safety of both concepts are ranked low due to the fact that there is an open spinning brush head that could cause harm to the user or dog.

**Table 4: Initial Design Decision Matrix**

Characteristics	Design One	Design two
Ergonomics	2	3
Cost	3	1
Manufacturability	4	4
Safety	1	2
Appearance	2	4

## **4. Project Scheduling**

### **4.1. Methodology**

Throughout the upcoming year, Team 17 plans to take this design project from its initial concept all the way to prototype and production phases. The design team plans to accomplish this by following a well-defined set of objectives and timetables as closely as possible, and adapting to any setbacks that may arise. The first steps in this process involve gaining an insight into the wants and needs of potential customers and determining if there is a market for our desired product, and what the risks are. Surveys will be performed on potential customers with questions that will help the team understand what engineering characteristics to focus on when the design begins. By obtaining the ‘voice of the consumer’, the team will better understand what features and characteristics are important to potential buyers. A risk assessment and failure analysis will also be conducted in order to determine what road blocks may lie ahead for this project and if it is an endeavor with a large enough profit to make it worth pursuing. After determining what engineering characteristics will be included in the product and conducting the risk analysis, the design phase will begin as the team begins to draft the chosen concept based on the information found from consumers. The tentative goal is to have a final prototype by the end of the fall semester.

## 4.2. Work Breakdown Structure

To help meet the deadlines set by the project sponsor as well as the team, it is important to keep track of deadlines for project deliverables. By creating a work breakdown structure as well as a Gantt chart, it becomes much easier to see what deadlines are coming up and stay ahead of them. Figure 2 below shows a basic work breakdown structure that lists the tasks that are critical to the completion of the project, and the progressive step by step process with which they must be accomplished.

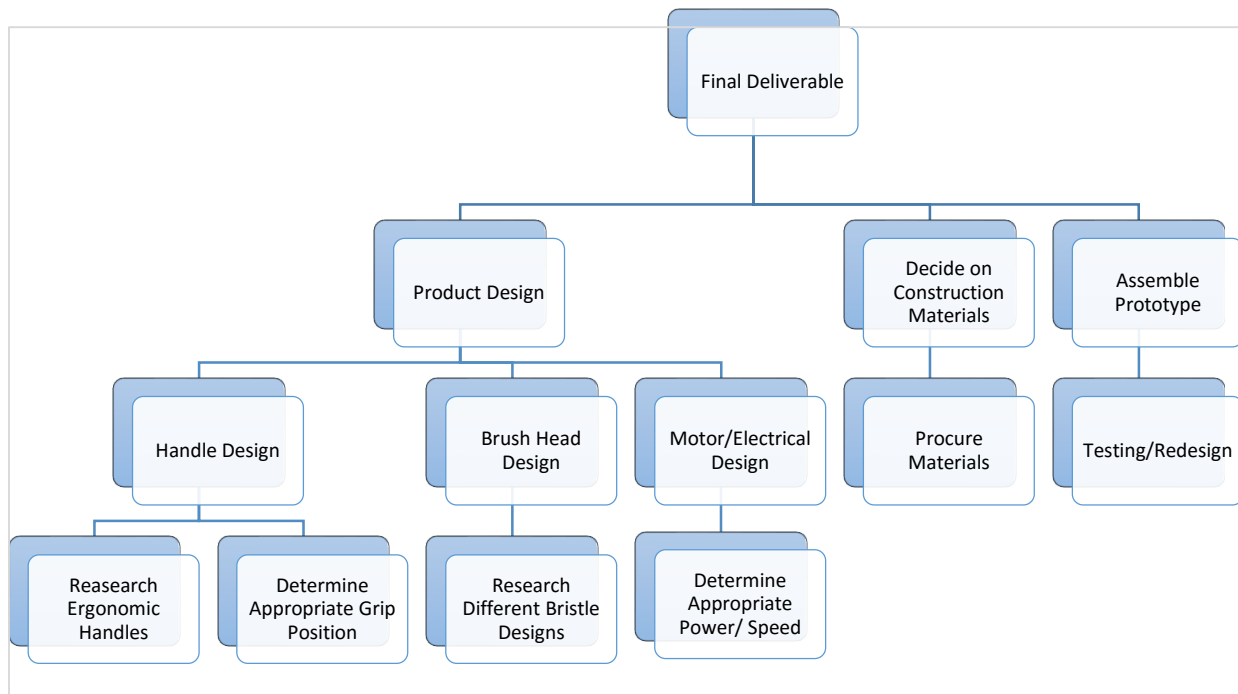

Figure 7: Work Breakdown Structure Diagram

## 4.3. Gantt Chart and Critical Path

Figure 3, shown below, is the revised Gantt chart diagram for the design project. In the left matrix, the Gantt chart display a list schedule of all the tasks of the design process that are to be completed during the 2015 fall semester. These tasks are linked and interrelated with one another based on the completion times and the design hierarchy of tasks. Not included on the Gantt schedule but still carried out by Team 17 are between the team and the sponsors. The hierarchy of tasks displayed in the Gantt create the critical path method for the project. The critical path method provides a timeline for the tasks to be done, and shows what tasks are dependent and independent of completion of preceding tasks. This allows there to be no stoppage in working as the team will know which things can be done while other tasks are pending.



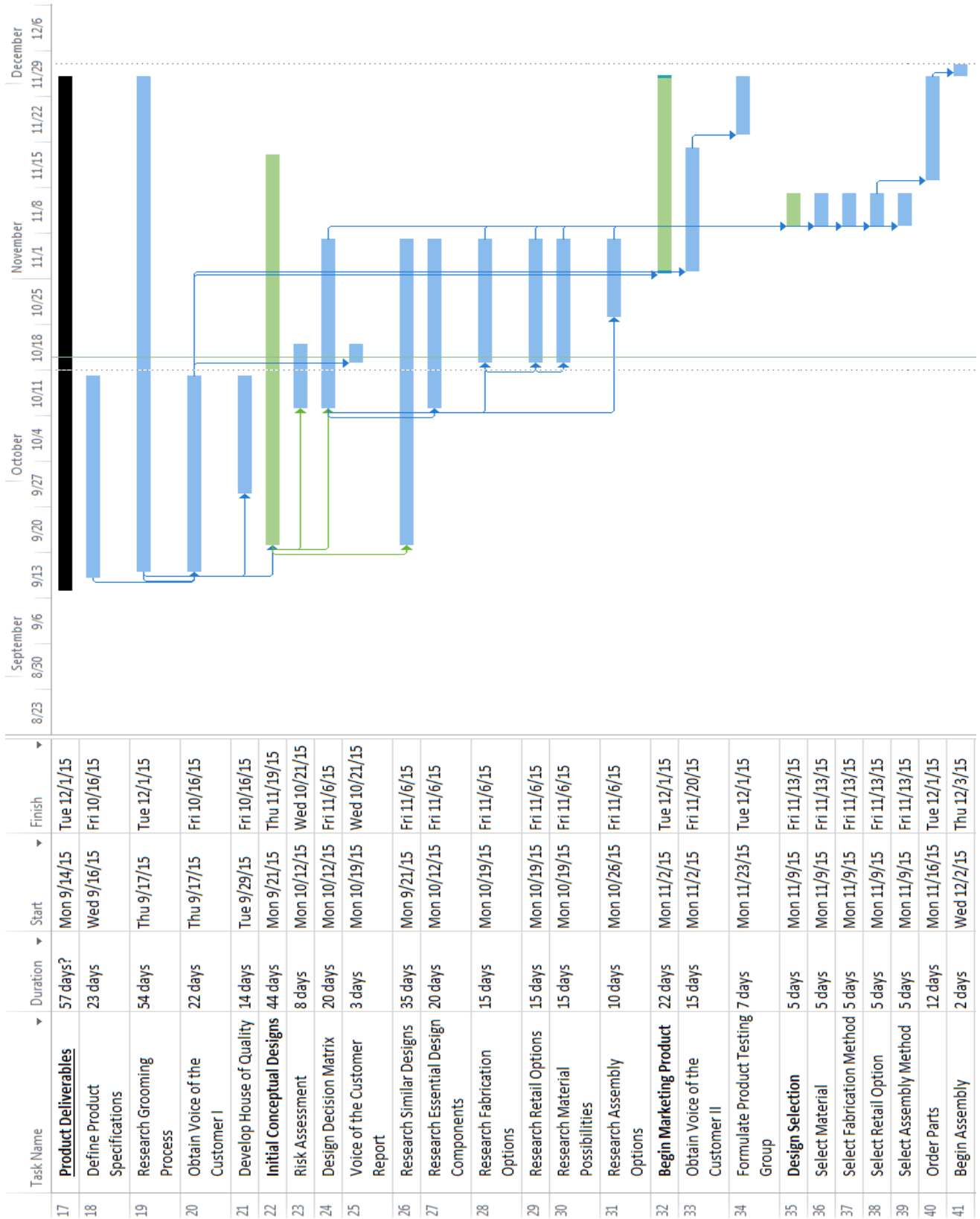

Figure 8: Revised Gantt Chart

## 4.4. Project Task List

**Table 5: Project Task Table**

<i>Task</i>	<i>Leader</i>
<i>Managing Records and All Documentations</i>	Jordan Chupp
<i>Liaison for Sponsors</i>	Justin Proctor
<i>Manage Scheduling</i>	Roy Mason
<i>Cost Analysis of Materials and Components</i>	Dennis Pugh
<i>Research Ergonomic Handles</i>	Jordan Chupp
<i>Determine Appropriate Grip Position</i>	Dennis Pugh
<i>Research Different Bristle Designs</i>	Roy Mason
<i>Determine Appropriate Power/Speed</i>	Team 17
<i>Procure Materials</i>	Justin Proctor
<i>Testing/Redesign</i>	Team 17

Table 3 above shows the upcoming tasks for Team 17 and which team member or members will be taking the lead on them.

## 5. Results

### 5.1 Risk Assessment

A risk assessment is essential because it provides team members with an awareness of the possible risks that lay ahead with the project so that the team never finds itself without a solution to a risen issue. The risk assessment conducted by Team 17 takes into account possible risks of the project as well as possible risks of the product that will be produced. For each listed risk within the risk assessment Team 17 also collaborated to come to a consensual contingency plan to address it. Below in Table 6 is provided a project risk assessment tabulating each foreseen risk along with its contingency option beside it. Appendix A1 also provides an official risk assessment document that includes the names and authorized signatures of each member of Team 17. A detailed risk assessment that will be developed along with the detailed decision matrix, will be used to address the risk associated with the selection of each possible brush tool components, as well as any other design decisions that are made.

**Table 6: Project Risk Assessment**

<b>Risks</b>	<b>Contingency Plan</b>
Allocated budget is not sufficient for prototype fabrication	Narrow project scope and perform cost analysis
Materials are not delivered on time	Order parts and materials early or in a timelier manner
Deadlines for things such as machining need to be extended	Stick to Gantt Chart schedule and look for other areas to make up the time later
Failure to develop functioning prototype	Have multiple concepts ready for prototyping and fabrication
Bristles harm pet when tool is operated	Design brush safety bumper to keep bristles from getting too close to dog's skin
Team members get electrocuted during assembly	Wear personal protective equipment such as gloves
Operator gets harmed from tool	Design an ergonomic handle and test to see any complications
Bristle head spins at a dangerous speed	Use low speed motor and test brush at multiple speed until desired speed is reached

## **5.2 Initial Testing**

Team 17 conducted testing with a constructed proof of concept design. Team 17 used took a human brush head and fastened it to the shaft of a Dremel tool shown below in Figure 9. The outcome of this test was that the mechanism actually worked in straightening the hair on the head of one of the team members. The mechanism did not hurt or tangle the hair and proved that the concept of a rotating brush head for matted dog coats was a viable possible solution.



*Figure 9: Dremel Tool*

## 6. Conclusion

Grooming a severely matted animal can be a long, stressful, and tiring process. This goal of this project is to make the grooming process much more enjoyable for both the pet and groomer. The team plans to examine the current methods used for grooming in order to develop an ideal product for future use. The team will use the resources of shadowing current groomers to learn the techniques used and issues encountered to continue the product design from an informed position

Team 17 understands that a strong planning stage sets the strong foundation for the rest of the design process. By developing a clear and concise schedule and delegating tasks to which each team member will be held accountable, Team 17 is putting itself in position to accomplish the goals and meet the needs and desires of the customers and sponsors.

Team17 has also learned and concluded from the current work done. That extensive research must be done in order to create a working product that accomplishes the project goals and objectives. The team also knows that understanding methods and techniques used to brush and de-mat dogs is very necessary, because it allows the team to know what issues the groomers and dog owners face and how they can be addressed. From the proof of concept test the team learned not only that the spinning brush concept is viable as a solution, but that further research must be done to determine optimal brush angular velocity and the other technical characteristics that are required.

## 7. Team 17 Biography

Justin Proctor is the team leader of Team 17. He is also an active member of the student chapter of Society of Automotive Engineers, where he serves as the head of the Baja Racing rear suspension unit. In his spare time Justin enjoys working on white Mazda Miata as a project car.

Jordan Chupp is the Team Secretary for Team 17. He is in charge of making sure that all notes are taken and that all minutes from any meetings we conduct are recorded. Justin is into archery as he likes going out to shoot his crossbow

Dennis Pugh is the Treasurer for Team 17. He is the head of managing our accounts, how much we have spent and what we have to spend. He is also in charge of submitting and keeping record of receipts, invoices, and any purchase orders. Dennis is a member of the Florida A&M University's Track and Field team.

Roy Mason is Team 17's Web Designer and Editor. He is responsible for editing and creating the layout of Team 17's webpage, as well as formatting, editing, and finalizing all reports and presentations for submission and use. Roy Mason is an active member of the Florida State University chapter of the Society of Automotive Engineers, where he serves on the executive board as club treasurer. He is also a part of the Baja Racing brake design unit. Roy Mason enjoys pencil sketching, playing basketball, and studying the Bible.

## 8. Acknowledgments

Team 17 would like to take the opportunity to make acknowledgements and express its gratitude to its external support for this project.

Team 17 would like to thank Dr. Simone Hrada, as she is the faculty advisor for Team 17. Dr. Hrada has been very helpful to Team 17 through her advice and council concerning key steps that were nearly missed and the acquiring of resourceful information that allowed Team 17 to gain a better understanding of what tasks need to be accomplished

Team 17 would also like to give thanks to Dr. Nikhil Gupta as well as Dr. Shih, for their continued guidance, evaluation and constructive criticism. Dr. Gupta and Dr. Shih have helped motivate Team 17 to stay on task and to have good schedule management.

Team 17 would like to express in gratitude to its team sponsors, William Billbow and Todd Hopwood. Team 17 is grateful for them for providing them with the opportunity to even embark on this project by being the first team to be a part of their engineering entrepreneurial incubating initiative. Team 17 would like to thank them for their support both financially and through the preliminary design and planning process.

A special thanks would like to giving from Team 17 to all those who participated in the consumer survey, with a major thanks to the Lori Williams at Paws and Claws for her willingness and openness to participate in the research and testing and trial phase.

## 9. References

- <sup>i</sup> *Furminator Deshedding Tool for Medium Dogs*. n.d. September 2015. <<http://www.petco.com/product/112965/FURminator-deShedding-Tool-for-Medium-Dogs.aspx>>.
- <sup>ii</sup> <http://www.furminator.com/>. 2015.
- <sup>iii</sup> *Infiniti Conair Spin Styler* . September 2015. <[http://www.amazon.com/Infiniti-Conair-Spin-Styler-2-Inch/dp/B004INUWX0/ref=zg\\_bs\\_11058221\\_1](http://www.amazon.com/Infiniti-Conair-Spin-Styler-2-Inch/dp/B004INUWX0/ref=zg_bs_11058221_1)>.

## **Appendix**

### ***A1: Risk Assessment Safety Plan (See Attachment)***