

Autonomous Ground Vehicle Design for Intelligent Ground Vehicle Competition

Project Update

Team 22: Allegra Nichols
Dalton Hendrix
Julian Wilson
Khoury Styles
Isaac Ogunrinde
And
Florida Institute of
Technology (FIT)



Sponsor: Aero-Propulsion Mechatronics and Energy Center

Advisor: Dr. Nikhil Gupta

January 19, 2016

Overview

- Introduction
 - Intelligent Ground Vehicle Competition
 - Team Dynamics
 - Work Distribution
- Competition Objectives
- Final Designs
 - Electrical Design Concepts
 - Mechanical Design Concepts
- Current Progress
- Looking to the Future

Introduction- Intelligent Ground Vehicle Competition (IGVC)

- Annual design competition held by Oakland University in Rochester, Michigan since 1997
- Provides hands on experience
- Focuses on latest technological advances
- Team development
- Inside view of industrial design
 - Team members in remote locations
 - Communication



An autonomous vehicle competing in the IGVC

Competition Objectives

The AGVs are required to navigate an outdoor obstacle course

- under 15 minutes
- Within speed restrictions
- Remain in lane
- Waypoint Identification
- Avoid Obstacles

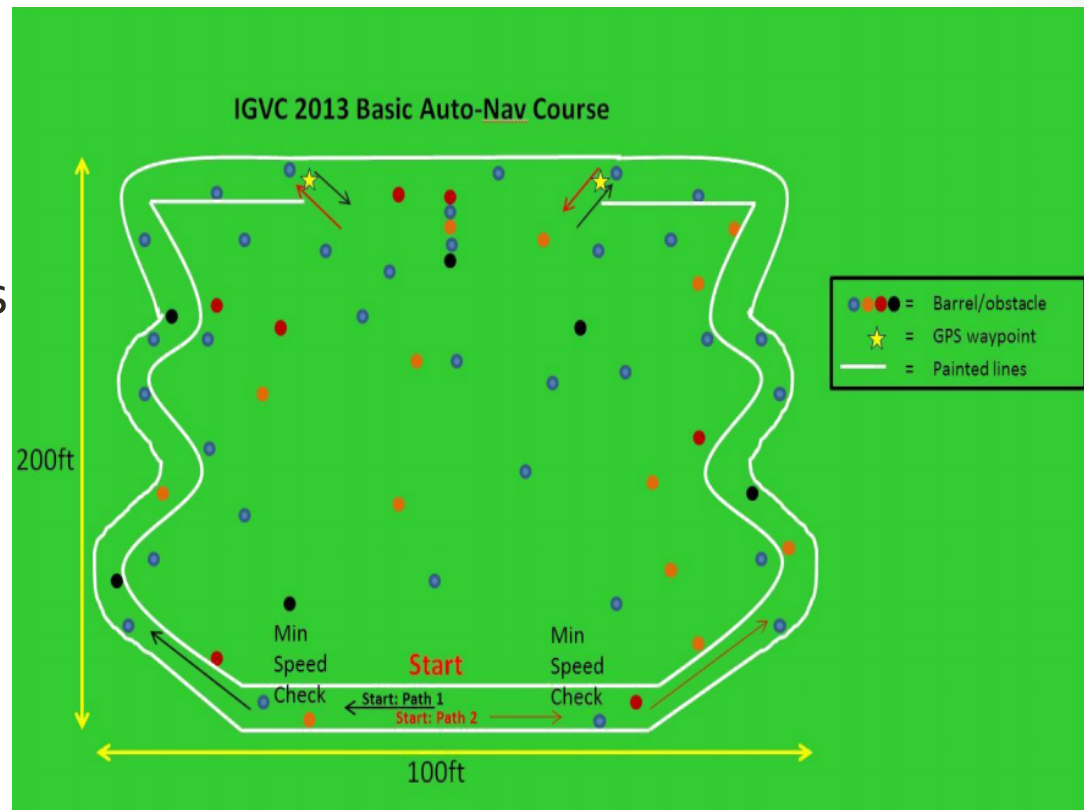

Layout of 2013 IGVC basic course

IGVC Design Constraints

- Dimension:
 - Length: 3~7 ft
 - Width: 2~4 ft
 - Height max: 6 ft
- On board Battery Power
- 1 ~ 5 mph Speed.
- On Board and Wireless Emergency Push Stop
- Safety light
- Payload: 20lb (18" x 8" x 8")

Introduction - Team Dynamics

- Multidisciplinary Distance Teamwork
- FAMU-FSU College of Engineering
- Junior FIT Team (Melbourne, FL)
 - 1 Computer Engineer
 - 1 Computer Science
 - 2 Mechanical Engineers
- Working toward the common goal of qualifying and competing in IGVC
- Biggest challenge is communication



*AGV attempting to avoid an
obstacle*

Introduction – Work Distribution

FAMU/FSU

- Structure Fabrication
- Vehicle Speed Control
 - Hall effects Integration
- Failsafe Sensor
 - Lidar Integration
- Emergency Stops
- Component Selection

FIT

- Onboard Power
- GPS Waypoint Navigation
- Vehicle Perception
 - PixyCam Integration
- Vehicle Intelligence
 - Neural Networking

Mechanical Design- Overview

- Aluminum 6061 square tubing frame
- Aluminum 6061 sheet enclosures for electronics enclosure and payload
- 4" trailing caster wheels
- 8" pneumatic drive wheels
- Aluminum 6061 wheel hubs
- Pololu 18v25 motor controllers
- Andymark PG27 gearboxes
- Andymark RS775 motors
- Hall-Effect encoders

Mechanical Design – Evolution of Design

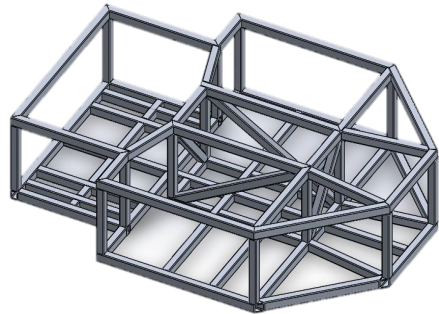

Initial Design

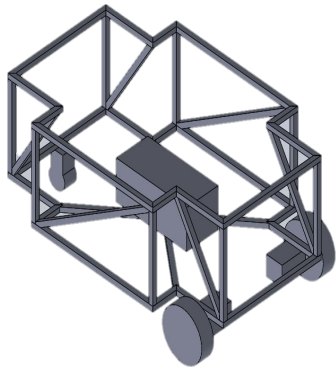

*Intermediate Design 1
(Revision 1)*

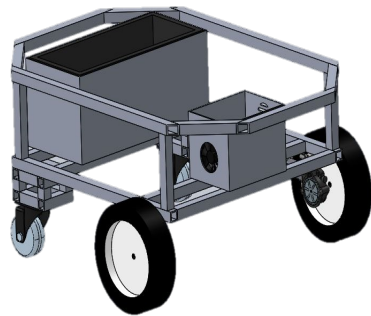

*Intermediate Design 2
(Revision 2)*

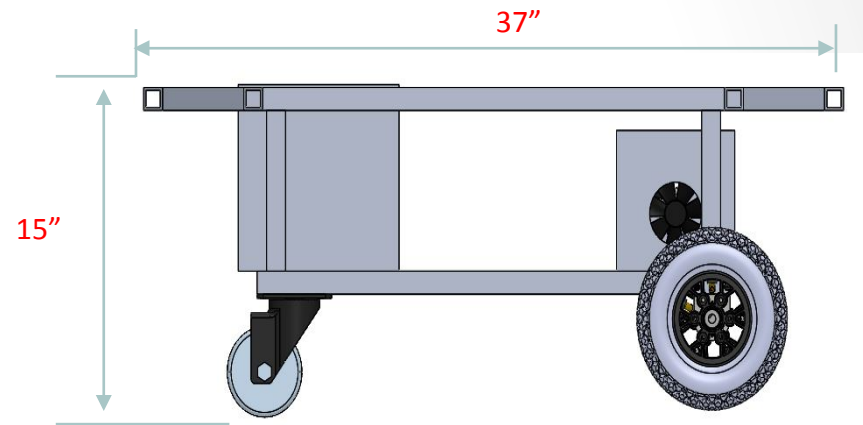

*Final Design Side (Revision
3)*

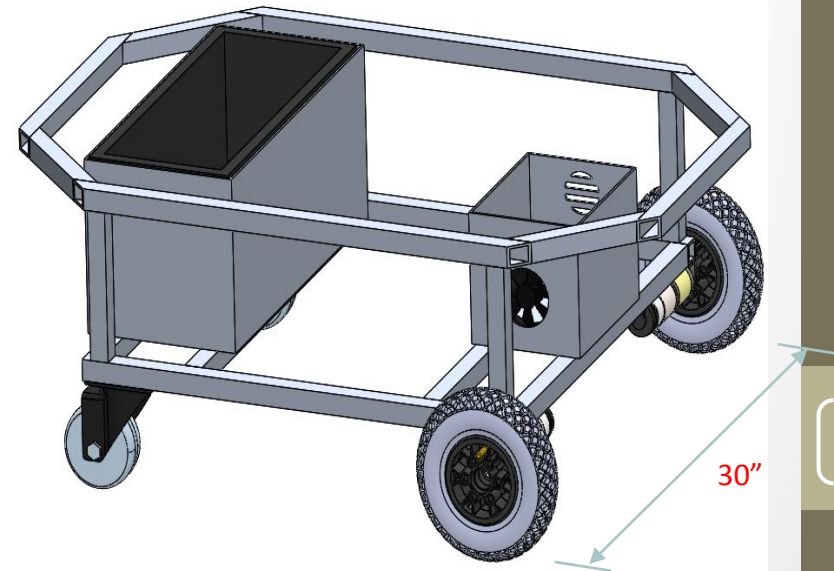

*Final Design Isentropic
(Revision 3)*

Mechanical Design Concept-Motor Selection

Gearmotor Specs:

- Overall Length: 6.125 inches
- Maximum Diameter: 1.775 inches
- Weight: 1.6 pounds
- Encoder: 7 Pulses Per Revolution of motor
 - 188.3 pulses per output revolution
- Gearbox Reduction: 26.9:1
- Voltage: 12 volt DC
- No Load Free Speed: 198 rpm
- Stall Torque: 6.3 ft*lbf
- Stall Current: 22 amps

Motor Driver Specs:

- Current: up to 25 Amps.
- Voltage: up to 24 Volts.



PG27 Planetary Gearbox with RS775 Motor and Encoder

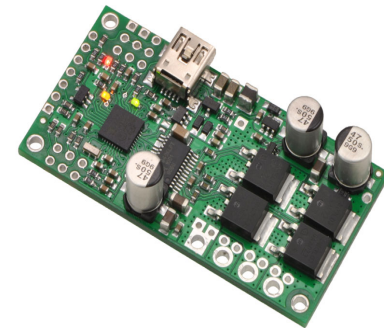

High-Power Motor Controller 18v25

Vehicle Prototype

- Structure from pine 2"x4" boards and 1/8" plywood
- Components can be mounted with ease by wood screws
- Materials are readily available



Electrical Design – Overview

- Processor
 - NI myRio 1900
 - Raspberry PI 2 Model B+
- Power
 - Lithium Ion
- Emergency Stop
 - Xbee 802.15.4
- Perception
 - PixyCMUCam
 - RPLIDAR A1M1

Electrical Design - Block Diagram

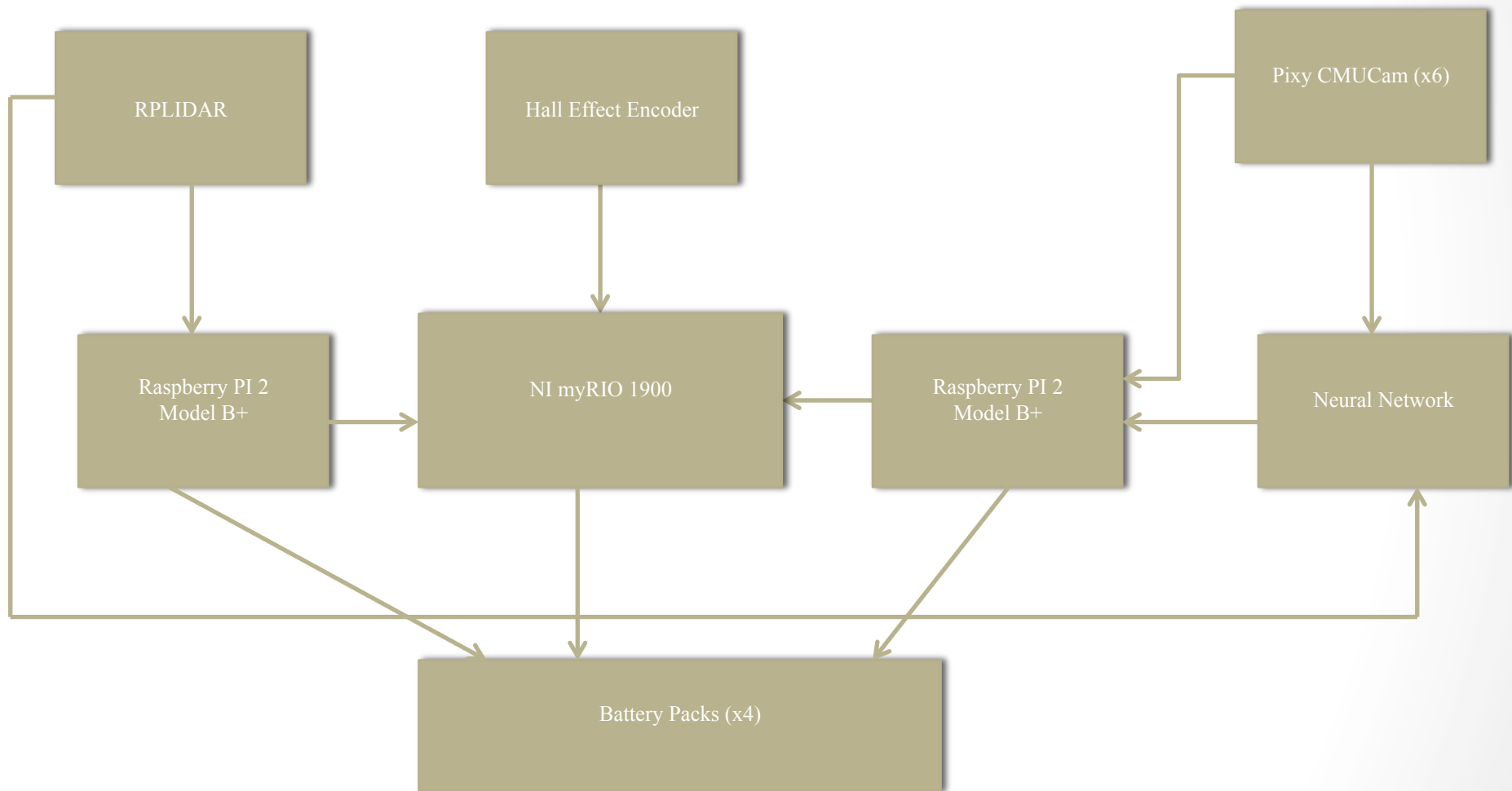

Electrical Design -Processors

MyRio 1900

- Xilinx Zynq 7 Series FPGA
 - Dual-core Cortex A9 Processor (667 MHz)
- 34- pin headers
- Integrated WIFI (150 m)
- 3 axis accelerometer
- 40 I/O pins
- 256 MB memory, 512 MB DDR3
- 14 W power consumption, 6-16 V operation voltage

Raspberry PI 2 – Model B+

- 40 GPIO pin header
- Broadcom BCM2835 processor (900 MHz)
 - Quad-core ARM Cortex A7 CPU
- 100 mps Ethernet port
- High efficiency power supply
- 1 GB RAM
- 5 V operation voltage

Electrical Design - Perception

RPLIDAR A1M1

- 360-degree 2D laser
- 2 -10 Hz Ranging
- 1-degree angular resolution
- 0.2cm distance resolution
- USB/UART compatible

PixyCMUcam

- Teachable camera
- 50 frames per sec
- up to 7 different color signatures
- 75 degrees horizontal , 47 degree vertical FOV
- 140 mA power consumption
- 5 V operation voltage
- Omnivision OV9715 image sensor
 - 1/4 " , 1280 x 800
- NXP LPC4330 Processor
 - Dual- Core (204 MHz)

Electrical Design – Emergency Stop

Xbee 802.15.4

- Multipoint wireless networking RF
- 2.4 GHz operating frequency
- 300 ft range
- 45mA transmit current, 50 mA receive current
- 3.3 operating voltage
- 250k bps
- -92 dBm receiver sensitivity

Challenges

- Starting from scratch
- FAMU/FSU-FIT Collaboration
 - Distance teamwork
 - Meshing Computer/Electrical and Mechanical Engineers
 - Coming to sound decisions
- Familiarizing with unexplored technologies
- Availability of Products
- Time Constraints

Gantt Chart

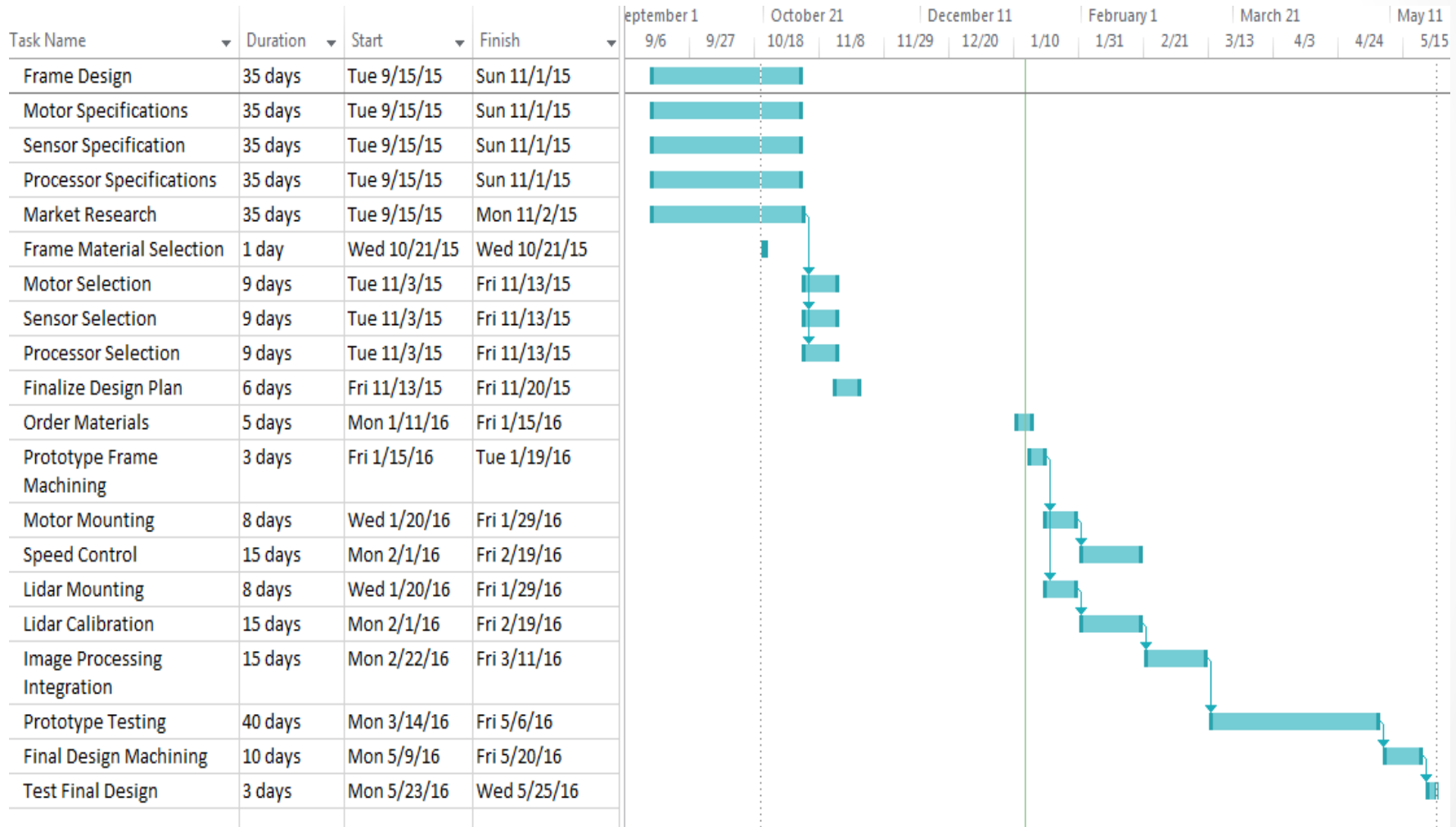

Gantt Chart

Order Materials	5 days	Mon 1/11/16	Fri 1/15/16
Prototype Frame Machining	3 days	Fri 1/15/16	Tue 1/19/16
Motor Mounting	8 days	Wed 1/20/16	Fri 1/29/16
Speed Control	15 days	Mon 2/1/16	Fri 2/19/16
Lidar Mounting	8 days	Wed 1/20/16	Fri 1/29/16
Lidar Calibration	15 days	Mon 2/1/16	Fri 2/19/16
Image Processing Integration	15 days	Mon 2/22/16	Fri 3/11/16
Prototype Testing	40 days	Mon 3/14/16	Fri 5/6/16
Final Design Machining	10 days	Mon 5/9/16	Fri 5/20/16
Test Final Design	3 days	Mon 5/23/16	Wed 5/25/16

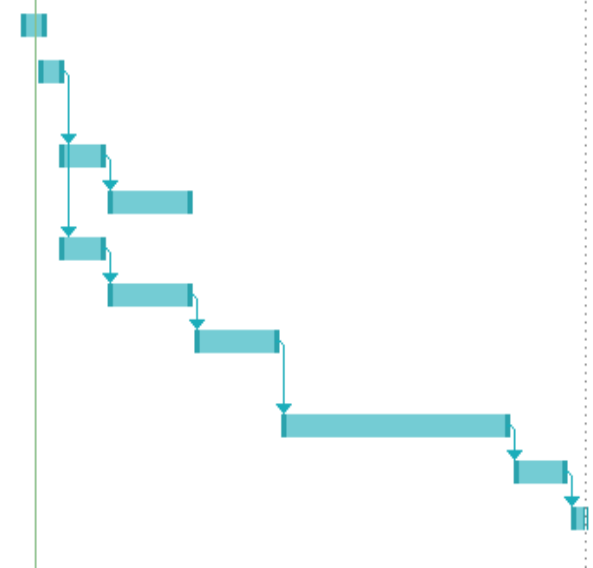

Current Progress

- Component ordering has been completed
- Wooden prototype fabrication
- Testing

Future Plans Outline

- Prototype testing
- Full electrical integration with prototype
- Bi-weekly conference calls with FIT
 - Collaborative updates

Reference

1. <http://www.igvc.org/objective.html>
2. <http://www.igvc.org/2016IGVCRules.pdf>
3. <http://www.robotmarketplace.com/products/AME-210-1012.html>
4. <https://www.pololu.com/product/1213>
5. <https://www.sparkfun.com/products/13680>

Questions?

House of Quality

Strong Positive	⊕
Positive	+
Negative	-
Strong Negative	⊖

Strong - 5
Medium - 3
Weak - 1

Engineering Characteristics	Design Requirement Weight	Design Requirements												
		Cost	Sensors	Power	Motor	Image Analysis	Programming	Microcontrollers	Interfacing	Mobility	Differential Drive	Speed Control	Weight	Body Styling
Vehicle Speed	5	1	1	3	5	1	3	5	3	5	5	5	3	1
Size	1	3	1	1	1	1	1	1	1	3	3	3	5	5
Lane Following	5	5	5	3	1	5	3	5	3	3	1	1	1	3
Obstacle Avoidance	5	1	5	1	5	5	3	5	3	5	3	3	1	1
Waypoint Navigation	3	3	3	1	1	1	3	5	3	1	1	1	1	1
Mechanical E-Stop	5	1	1	1	1	1	3	3	3	1	1	3	1	5
Wireless E-Stop	5	1	5	1	1	1	3	3	3	1	1	3	1	1
Absolute Importance		57	95	49	69	69	85	121	85	81	61	81	43	63
Relative Importance		6	11	6	8	8	10	12	10	9	7	9	5	7
Rankings		6	2	7	5	5	3	1	3	4	6	4	8	6

Decision Matrices

Steering	Base	Control	Feasability	Speed	Total
Differential Steering	0	7	7	7	21
Skid Steering	0	7	5	5	17
Tank Tread	0	5	3	3	11
Steering Fans	0	3	3	5	11
Ackerman Steering	0	5	0	5	10

Body Structure	Base	Manufacturability	Weight	Availability	Total
Tubing Frame	0	7	5	7	19
Sheet Material	0	7	5	5	17
3D Printed	0	5	5	3	13
Hovercraft	0	3	7	5	15

Materials	Base	Machinability	Density	Availability	Total
4130 Steel	0	7	3	5	15
Aluminum 6061	0	7	5	7	19
ABS Plastic	0	5	7	5	17
Wood	0	5	7	5	17

Decision Matrices

Processor	Base	Power Consumption	Processor Speed	Memory	Total
NI MyRio 1900	0	5	5	5	15
Raspberry PI 2	0	5	7	7	19
Arduino	0	5	3	3	11
MSP430	0	5	3	3	11

Sensor	Base	Accuracy	Range	Speed	Total
Infrared	0	5	0	5	10
Ultrasonic	0	3	5	7	15
Radar	0	3	5	5	13
Lidar	0	7	7	7	21

Vision	Base	Resolution	Intigration	Accuracy	Total
Pixi Cam	0	7	7	5	19
USB Camcorder	0	5	3	5	13

Power	Base	Capacity	Voltage	Weight	Total
Lead Acid	0	7	5	5	17
Lithium Ion	0	7	7	7	21
Nickel-Metal Hybrids	0	7	5	5	17
Lithium Polymer	0	7	5	3	15