

# Development of a Semi-Autonomous Oil Palm Fruit Harvesting Device

---

## IME Group 10: Analyze Phase

A report submitted to Dr. Okenwa Okoli  
Industrial & Manufacturing Engineering Department

Diez, Gabriel  
Gerstenblitt, Matthew  
Gonzalez, Enrique  
Howard, Patrick  
Machado, Alberto  
Morin, Derek  
Vetencourt, Maria Daniela

January 29, 2016

This report is the third of five progress reports. It defines the opportunities and constraints of this project, following the Six Sigma methodology of “Define, Measure, Analyze, Improve, Control” (DMAIC). The team’s approach, deliverables the team will provide at the termination of the project, detailed descriptions of the customer requirements and previous design concepts, and an analysis of the team’s selected design are provided.

## Table of Contents

List of Figures .....	iv
List of Tables .....	vii
Abstract .....	ix
1. Introduction.....	10
2. Project Charter .....	4
2.1 Project Overview.....	4
2.1.1 Objectives and Expected Benefits .....	4
2.1.2 Business Case.....	6
2.1.3 Project Stakeholders and Team Organization.....	10
2.2 Approach .....	14
2.2.1 Scope.....	14
2.2.2 Assumptions and Constraints.....	15
2.2.3 Deliverables .....	17
2.2.4 SIPOC Diagram .....	19
3. Defining Customer and Technical Requirements.....	20
3.1 Customer Requirements .....	20
3.2 Technical Requirements.....	23
3.3 Current Harvesting Process .....	25
3.4 Need for an Electromechanical Harvesting Device .....	27
3.5 House of Quality .....	28
3.5.1 Relationships.....	29
3.5.2 Correlations.....	34
3.5.3 Calculations.....	38
3.6 Work Breakdown Structure.....	42
3.7 Responsibility Assignment Matrix.....	44
4. Selected Design.....	46
4.1 Previous Design Ideas .....	46
4.1.1 Improving the Class of 2015’s Design.....	46
4.1.2 Extended Pole Pruner.....	47
4.1.3 Tree Crawler .....	49

4.2	The Pole.....	50
4.3	The Ring.....	52
4.4	Cutting Mechanism .....	56
4.5	The Base.....	64
5.	Analysis of Selected Design .....	69
5.1	Modifications .....	69
5.1.1	Cutter.....	69
5.1.2	Ring.....	70
5.1.3	Pole .....	72
5.1.4	Cart.....	75
5.1.5	Electrical Components .....	76
5.2	Testing.....	78
6.	Business Analysis .....	88
6.1	Economic Analysis.....	88
6.2	Environmental Impact .....	89
6.3	Ethical Considerations.....	90
6.4	Health and Safety .....	90
6.5	Social and Political Considerations.....	91
6.6	Sustainability.....	92
7.	Project Progress .....	92
7.1	Milestones and Schedule .....	92
7.1.1	Define Phase Tasks .....	92
7.1.2	Measure Phase Tasks .....	103
7.1.3	Analyze Phase Tasks.....	113
7.1.4	Improve Phase Tasks .....	120
7.1.5	Control Phase Tasks.....	127
7.2	Risk Management.....	134
7.3	Budget and Bill of Materials .....	137
7.3.1	Estimated Budget .....	137
7.3.2	Actual Expenditures and Bill of Materials.....	140
8.	Conclusion .....	143

9. References.....	147
Appendix A: Return on Investment Calculations .....	152
Appendix B: Estimated Budget Tables.....	153

## List of Figures

Figure 1: Composition of World Oil Production by Mass [1] .....	6
Figure 2: Average Oil Yield in pounds per acre of the Top Four Oil Sources [1] .....	7
Figure 3: Composition of World Oil Crop Area [1] .....	7
Figure 4: Threats and Opportunities Matrix .....	9
Figure 5: Team Organization Diagram .....	13
Figure 6: SIPOC Diagram.....	19
Figure 7: Voice of the Customer Diagram.....	21
Figure 8: Current Oil Palm Fruit Harvesting Method for Tall Trees [2] .....	26
Figure 9: Ishikawa Diagram of the Palm Harvesting Process [2].....	27
Figure 10: House of Quality .....	41
Figure 11: Work Breakdown Structure.....	43
Figure 12: Previous Group’s Design [9].....	46
Figure 13: Extendable Gas-Powered Saw [15].....	47
Figure 14: Modified Pole Pruner Framework.....	48
Figure 15: Tree Crawler Operation Process.....	49
Figure 16: Circular Cutter Track.....	53
Figure 17: Stress Analysis of the Ring .....	54
Figure 18: Displacement Analysis of the Ring.....	55
Figure 19: Cutting Mechanism .....	57
Figure 20: Arduino UNO Microcontroller [20] .....	58
Figure 21: L293D H-bridge Motor Driver [21] .....	58
Figure 22: Pin layout of L293D [22] .....	58
Figure 23: Stepper Motor Forward Sequence [23] .....	59
Figure 24: DC Motor [24].....	60
Figure 25: Stepper Motor [25] .....	60
Figure 26: Cutting Mechanism Schematic.....	63
Figure 27: Receiver (left) and Transmitter (right) [26] .....	63
Figure 28: Arduino Joystick Shield [28].....	63
Figure 29: Joystick Shield Schematic [29] .....	64
Figure 30: Camera and Monitor [30] .....	64

Figure 31: Rendering of the Base .....	65
Figure 32: Stress Analysis of the Aluminum Joint, Top View .....	66
Figure 33: Stress Analysis of the Aluminum Joint, Side View .....	67
Figure 34: Stress Analysis of the Pin for Base Leg .....	68
Figure 35: Modified Cutting Mechanism .....	70
Figure 36: Deflection Analysis of Modified Ring .....	70
Figure 37: Stress Analysis of Modified Ring .....	71
Figure 38: Previous Year's Pulley Mechanism .....	72
Figure 39: FEA of the Class of 2015's Design [9] .....	73
Figure 40: Deflection Analysis of the Class of 2015's Design .....	74
Figure 41: Cart .....	75
Figure 42: Stress Analysis of the Cart .....	76
Figure 43: Winch Motor .....	77
Figure 44: 12V Super State Marine Deep Cycle Battery.....	78
Figure 45: Motor Driver for Winch Motor .....	78
Figure 46: Receiver Testing Circuit.....	79
Figure 47: Transmitter Testing Circuit .....	80
Figure 48: Transmitter Testing Code.....	80
Figure 49: Receiver Testing Code .....	81
Figure 50: Controller Testing Code for Transmitter.....	82
Figure 51: Controller Testing Code for Receiver .....	83
Figure 52: Graph Definition of PWM.....	84
Figure 53: Testing Code for DC Motors and Winch .....	85
Figure 54: Stepper Motor Testing Circuit.....	86
Figure 55: Testing Stepper Motor Code .....	87
Figure 56: Saw Testing Code.....	88
Figure 57: Network Flow Diagram for the Define Phase .....	98
Figure 58: Gantt Chart for the Define Phase .....	102
Figure 59: Network Flow Diagram for the Measure Phase .....	108
Figure 60: Gantt Chart for the Measure Phase.....	112
Figure 61: Network Flow Diagram for the Analyze Phase.....	116

Figure 62: Gantt Chart for the Analyze Phase .....	119
Figure 63: Network Flow Diagram for the Improve Phase .....	124
Figure 64: Gantt Chart for the Improve Phase.....	126
Figure 65: Network Flow Diagram for the Control Phase.....	131
Figure 66: Gantt Chart for the Control Phase .....	133
Figure 67: SWOT Matrix.....	134
Figure 68: Upper Portion of a Generic Palm Tree [36] .....	137
Figure 69: Risk Matrix.....	137
Figure 70: S-Curve.....	143

## List of Tables

Table 1: Project Sponsor's Requirements.....	4
Table 2: Descriptions of Short-Term Threats and Opportunities .....	9
Table 3: Descriptions of Long-Term Threats and Opportunities.....	10
Table 4: Project Assumptions and Constraints [2], [9], [11] .....	16
Table 5: Project Deliverables.....	18
Table 6: Descriptions of Customer Requirements .....	22
Table 7: Descriptions of Technical Requirements.....	23
Table 8: Explanation of "One Operator" Relationships.....	29
Table 9: Explanation of "Lightweight/Portable" Relationships.....	30
Table 10: Explanation of "Better than Current Harvesting Methods" Relationships .....	31
Table 11: Explanation of "Waterproof" Relationships .....	32
Table 12: Explanation of "Durable" Relationships.....	32
Table 13: Explanation of "High Capacity Power Source" Relationships .....	33
Table 14: Explanation of "Below \$2,000" Relationships .....	33
Table 15: Explanation of "Low Maintenance Expenses" Relationships .....	34
Table 16: Explanation of "System Weight" Correlations .....	35
Table 17: Explanation of "Modular" Correlations.....	35
Table 18: Explanation of "Strength of Materials" Correlations.....	35
Table 19: Explanation of "Energy Capacity" Correlations.....	35
Table 20: Explanation of "Shielded Electronics" Correlations.....	36
Table 21: Explanation of "Fruit Visibility" Correlations.....	36
Table 22: Explanation of "Electromechanical Components" Correlations.....	36
Table 23: Explanation of "Setup Time" Correlations .....	37
Table 24: Explanation of "Autonomy" Correlations .....	37
Table 25: Explanation of "Number of User Controls" Correlations.....	37
Table 26: Explanation of "Harvesting Time" Correlations.....	38
Table 27: Explanation of "Training Time" Correlations .....	38
Table 28: Values Used to Compute the Weighted Importance of the "Training Time" Technical Requirement.....	39
Table 29: Weighted Importance Values of Each Technical Requirement.....	40



Table 30: Responsibility Assignment Matrix .....	44
Table 31: Ergonomic Risk Factors on Oil Palm Plantations [32].....	91
Table 32: Major Tasks for the Define Phase .....	93
Table 33: Detailed Network Flow Diagram Information for Define Phase Tasks .....	99
Table 34: Major Tasks for the Measure Phase.....	104
Table 35: Detailed Network Flow Diagram Information for Measure Phase Tasks .....	109
Table 36: Major Tasks for the Analyze Phase .....	113
Table 37: Detailed Network Flow Diagram Information for Analyze Phase Tasks.....	117
Table 38: Major Tasks for the Improve Phase.....	121
Table 39: Detailed Network Flow Diagram Information for Improve Phase Tasks.....	125
Table 40: Major Tasks for the Control Phase .....	128
Table 41: Detailed Network Flow Diagram Information for Control Phase Tasks .....	132
Table 42: Budget Based on the Most Likely Cost of the Components.....	138
Table 43: Budget Based on the Optimistic Cost of the Components .....	138
Table 44: Budget Based on the Pessimistic Cost of the Components .....	139
Table 45: Final Budget Based on a Weighted Average of Three Budgets .....	140
Table 46: Budget and Bill of Materials.....	141
Table 47: Estimated Budget for the Ring and Cutter Mechanism .....	153
Table 48: Bill of Materials for the Ring and Cutter Mechanism .....	154

## **Abstract**

In this report, the development of an electromechanical system to harvest oil palm fruit is discussed. An analysis of the global oil market illustrated that approximately one third of all oils produced is made from oil palm fruit. Since oil palms yield approximately 3,300 pounds of palm oil per planted acre per year and are the most efficient oil-producing crop, there is a large demand for palm oil. The current oil palm fruit harvesting method consists of a worker ascending a tree that is a maximum of 40-feet tall, manually cutting the fruit bunch, and then descending the tree. Dr. Okenwa Okoli, Chair of the Department of Industrial and Manufacturing Engineering at the College of Engineering of Florida Agricultural and Mechanical University and Florida State University, believes that the current harvesting method is dangerous and inefficient. He has sponsored this project with the intent of replacing the current climbing process by developing a portable and simple electromechanical device that improves workers' safety and productivity. Dr. Okoli's design requirements and the timeline for the entire project are discussed extensively in this report. \$2,500 was allocated for the development of the device, while a target selling price of \$2,000 was established to ensure that the device can be sold in developing countries.

This report also discusses the reasons behind the elimination of the old design and why it was found infeasible. The new design consists of a semi-circular track that is attached to a telescoping pole. Neither the pole nor the track attach to the tree in any way. The track and pole are transported from tree to tree by pulling a cart. The telescoping poles concept was adopted and improved from last year's design, which had portability issues. Finite element analyses were then conducted on the components of the design to determine if it could achieve design requirements. The electronic components that have arrived have been tested, while others are still in transit.

After some minor modifications, the analyses indicated that the design is ready for the next phase.

## **1. Introduction**

The oil palm can easily be called the greatest oil-producing crop in the world. Capable of producing up to approximately 3,300 pounds of palm oil annually per acre of oil palm trees planted, it is the ideal plant to meet the global food market's demand for cooking oil [1]. It is not surprising, then, that it is responsible for 36% of all oil produced globally, while only encompassing 5% of the farm land used for oil [1]. Therefore, even a slight modification to the oil palm harvesting process could greatly increase production capacity.

Currently, the process by which oil palm fruits are harvested involves a worker ascending a tree and manually cutting each fruit bunch [2]. Since the trees are grown in developing countries whose workers are paid very low wages, this process is fairly inexpensive [3]. However, there are many disadvantages to this manual process. Laborers experience poor working conditions, such as climbing a maximum of 40 feet by wrapping their arms around the oil palm tree's trunk. These conditions result in workers being diagnosed with various musculoskeletal disorders [2]. Additionally, the process of ascending oil palms is slow and exhausting, necessitating a large work force. For example, a 6,400-acre oil palm plantation requires 333 workers. Therefore, one worker is theoretically responsible for walking approximately 19 acres per day. Roughly one Imperial ton per worker is expected to be harvested each day [4].

The project's sponsor, Dr. Okenwa Okoli, chair of the Department of Industrial and Manufacturing Engineering (IME) at the College of Engineering of Florida Agricultural and

Mechanical University and Florida State University (FAMU-FSU College of Engineering), believes that the current process for harvesting oil palm fruit can be improved. Since the multibillion dollar palm oil industry [5] depends on such an inefficient harvesting method, developing a device to improve current harvesting methods would increase oil palm fruit production capacity and result in millions of dollars of increased revenue and savings for companies involved in the industry.

The team's task is to develop an electromechanical device that can safely and easily harvest ripe oil palm fruit in a way that is less expensive and more productive than hiring a person to do it. Since this device is intended to replace the work of one person, the sponsor has specified that it must require no more than one operator. Furthermore, this electromechanical device must be able to operate in the equatorial tropical regions where oil palm trees are planted [2]. Finally, since the farmers that grow oil palm trees generally live in developing countries [1], it is essential that the selling price of the final design be low enough to make it marketable.

Two different approaches to designing a harvesting device have been attempted in the past years. The Class of 2012's design involved a tree-climbing robot that would gradually climb up to the top of the tree and cut fruit [6]. However, once the prototype was built, it was too heavy to transport from tree to tree and Dr. Jonathan Clark strongly advised the project's team not to program it to climb the tree because it would endanger individuals on the ground. The project was not assigned to the Class of 2013 [7]. The Class of 2014 designed a system that utilized telescoping polyvinyl chloride (PVC) poles that were transported on a cart; the poles extended a saw upward to cut oil palm fruit bunches [8]. The Class of 2015's design replaced the PVC poles with aluminum [9]. Upon completion, the design was too heavy to be pushed through the rough

terrain of an oil palm fruit plantation, too unstable to ensure the safety of the operators, and too difficult to assemble, because the poles were too long.

In the Measure Phase, the approach for the development of the prototype's design was divided into a top cutting mechanism and base support system. The top cutting mechanism involves a structure that encircles the trunk of the tree and cuts the oil palm fruit bunch while being controlled from the ground. The base support system holds the weight of the whole mechanism using a series of interconnected poles to push the cutting tool upward. However, in this phase, it was determined that in order to make a functional poling system, the amount of material required would be too heavy to be transported by hand. Therefore, in this report, a new design is selected that modifies the poling system from the Class of 2015's design to be more transportable, in addition to adding the team's new ring design to improve the cutting mechanism.

In this report, the requirements for developing an electromechanical oil palm fruit harvesting device are defined. First, background research of the palm oil industry and an analysis of the market potential of an oil palm fruit harvester are presented. Next, the technical requirements necessary to complete the customer's needs are determined. Furthermore, the entire project's schedule is outlined and several rudimentary design concepts are discussed. The selected design presented utilizes aspects of these design concepts. Renderings are then shown that were made using Creo Parametric software that allowed finite element analyses to be conducted. The results of these analyses of the components' displacements and stresses under internal and external loads are then presented. The electronic components for the cutter were also

tested in this phase and the results are presented. Finally, the bill of materials needed for the prototype is provided.

## 2. Project Charter

### 2.1 Project Overview

#### 2.1.1 Objectives and Expected Benefits

The objective of this project is to design a mechanism and build a prototype of a device that can harvest oil palm fruit semi-autonomously with only one operator. The mechanism must be able to reach the top of the palm tree, allow the operator to determine which bunches of fruit are ripe, and cut the ripe bunches. This project prohibits the device's operator from being physically lifted to the top of the oil palm tree and cutting the oil palm fruit. However, a worker is permitted to operate the device from the ground. The detailed requirements obtained from the team's meetings with Dr. Okoli are described in Table 1.

**Table 1: Project Sponsor's Requirements**

Requirement	Description
1. Low Cost	The device must be able to be sold at a retail price of no more than \$2,000. The device must also only require minimal maintenance to assist in minimizing the cost of ownership.
2. Portable	The device must be able to maneuver from oil palm to oil palm in rough terrain. For a freestanding design, this means the prototype must be lightweight.
3. Efficient	The device must be able to harvest oil palm fruit faster than human workers are able to harvest them. In addition, the harvesting time should be no greater than 20 minutes. Furthermore, the device is to be operated by no

	more than one worker.
4. Easy to Use	The device must be operable by current oil palm fruit harvesters. This means that the prototype must have simple controls that require only a short training period.
5. Durable	The device must be able to withstand tropical conditions, as well as be able to effectively traverse through rough terrain. Furthermore, the device must be able to withstand any impacts from the oil palm trees it might encounter.
6. Safe	The device must minimize the risk of injury or death to the operator or bystanders when it is being used. This means that any cutting mechanisms attached to the device must be secured physically, without the use of adhesives.
7. Environmentally Friendly	The device cannot cause any damage to the oil palm trees when it is harvesting fruit.

There are many ways meeting the objectives described in Table 1 would benefit society. Developing a low-cost harvesting device would allow plantation owners to be able to justify the expenditure in the long run, while making the device portable, efficient, and safe would allow a worker to harvest oil palm fruit in a much more effective manner than the current methods used [2]. Making the device is easy to use will allow the current harvesters to be able to operate it, while ensuring the device does not damage the tree will allow oil palm fruits to be harvested again in the future. Furthermore, the most tangible benefit of a successful prototype is the improved safety of the oil palm harvesters who currently climb trees as high as 40 feet to cut oil palm fruit bunches [2].

### 2.1.2 Business Case

There are four oils that account for 99% of annual global oil production by mass. These oils and their respective compositions are depicted in Figure 1 [1].

**World Oil Production Composition by Mass**

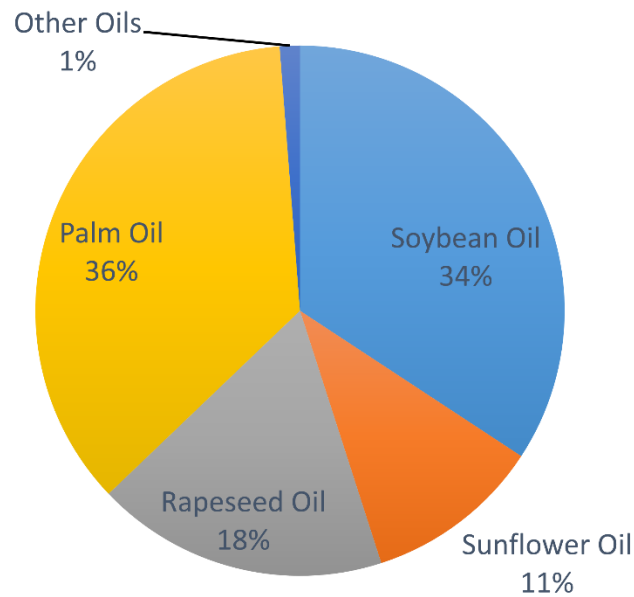
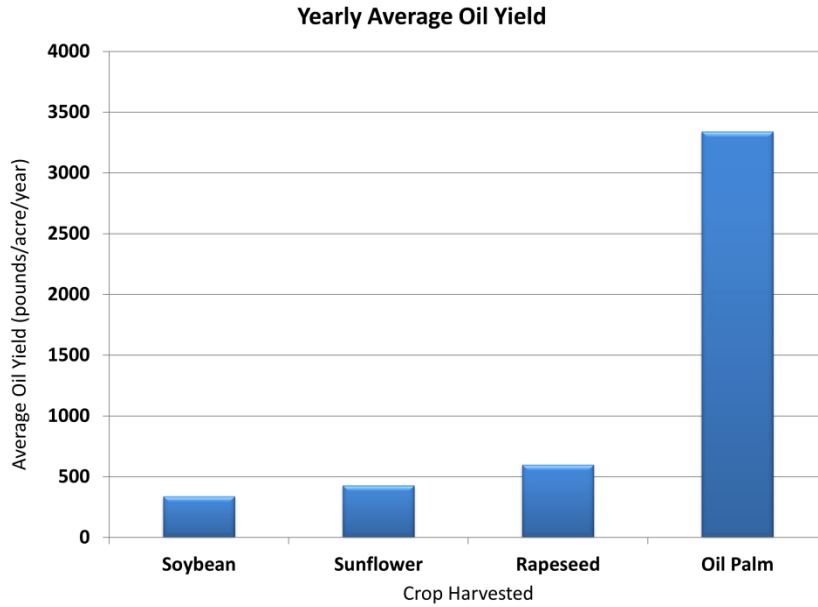

**Figure 1: Composition of World Oil Production by Mass [1]**

Figure 1 illustrates that palm oil is the most produced oil each year. Currently, the palm oil industry is valued at \$44 billion [5] and is projected to increase by more than 65% by 2020 [10]. Additionally, 50% of consumer products that are used daily contain palm oil [11].

Oil palm fruit also yield a much larger quantity of oil than soybeans, rapeseeds, and sunflowers. The yearly average yield of each crop [1] in pounds per acre planted is depicted in Figure 2.

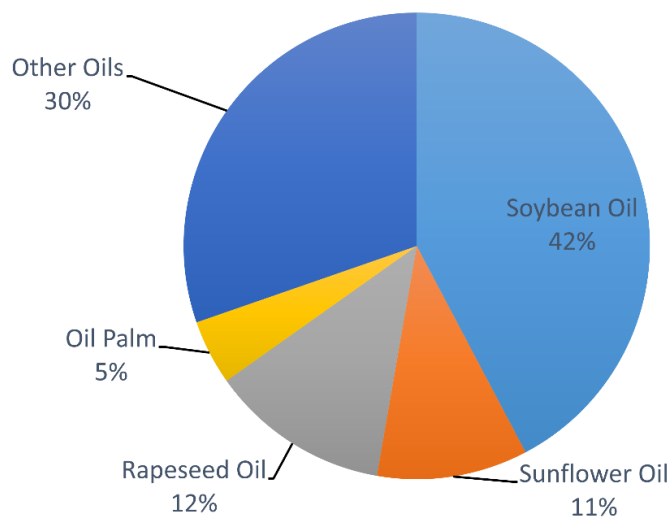



**Figure 2: Average Oil Yield in pounds per acre of the Top Four Oil Sources [1]**

In addition to oil palm fruit being used to produce 36% of the world’s oil (Figure 1), the fruits also produce approximately seven times more oil than rapeseeds, the crop with the second highest yield per acre (Figure 2). The composition of oil crops by area is depicted in Figure 3 [1].

### World Oil Crop Area Composition



**Figure 3: Composition of World Oil Crop Area [1]**

In addition to oil palm fruit having the most efficient yield of any crop, Figure 3 illustrates that the fruit comprise the smallest area among all planted oil producing crops. Oil palm trees' relatively small crop area, coupled with oil palm fruit's high oil yield, helps explain why oil palm fruit are the most popular source of oil. However, oil palm fruit are currently harvested in a hazardous and inefficient manner. Laborers must climb oil palm trees that are 40-foot high, identify if the fruit are ripe, cut the proper ripe fruit bunch, and then descend the tree, while avoiding the many protrusions of the oil palm tree's trunk, and avoiding damaging the remaining fruit bunches [2].

It is evident that oil palm fruit are important to worldwide oil production; however, current harvesting techniques can be improved. From a business standpoint, there is a \$44 billion market [5] that currently has no competition or innovation in improving oil palm harvesting techniques. As the world's population continues to increase, demand for palm oil, used in 50% of consumer goods [11], will also increase. There will be increased pressure to harvest only crops that have high oil yields to ensure that customers from many countries can afford to purchase them. Thus, there will be a great demand for efficient sources of oil, such as palm oil. Currently, the target consumers of an oil palm fruit harvesting mechanism are oil palm plantation owners and workers in Indonesia and Malaysia, because these two countries produce 85% of the world's palm oil [12]. In addition, plantation owners or workers in any country that wish to increase harvesting efficiency are also considered target consumers. These customers' needs were analyzed and a Threat and Opportunities matrix intended to address these needs was developed and is shown in Figure 4. The threats are displayed in red and opportunities are displayed in green. More information regarding short-term threats and opportunities is given in Table 2, while further descriptions of long-term ones are given in Table 3.

	Threats	Opportunities
Short Term (Less than 6 Months)	Develop an infeasible design Hire more unskilled laborers to harvest oil palm fruit Damage oil palm trees with the prototype Harvest unripe fruit with the prototype	Conceive an innovative design Decrease amount of harvesters needed Develop a design that does not harm oil palm trees Develop a device that can only discern ripe oil palm fruit
Long Term (More than 6 Months)	Continue to endanger harvesters Increasing palm oil prices Harvesting methods do not change Decreasing oil palm fruit harvesting efficiency research	Increasing safety in work environment Increasing harvesting efficiency causes decrease in palm oil prices Revolutionize the palm oil harvesting industry Increasing oil palm fruit harvesting efficiency research

**Figure 4: Threats and Opportunities Matrix**

**Table 2: Descriptions of Short-Term Threats and Opportunities**

Threat	Threat Description	Opportunity	Opportunity Description
No feasible design developed.	This means that the project will not be able to be completed, because a prototype cannot be improved if it does not exist.	Conceive an innovative design.	This means that an original design could be developed that will be able to harvest oil palm fruit without a worker climbing the tree.
More unskilled laborers hired to harvest oil palm fruit.	Palm tree plantation owners will have to continue searching for unskilled laborers willing to ascend oil palm trees to harvest oil palm fruit.	Decrease amount of harvesters needed.	A harvesting device would decrease the amount of harvesters that are needed to climb and cut oil palm fruit, because the device will be able to harvest more fruit than a human can.
Prototype could damage oil palm trees.	If the prototype is not designed correctly, it may result in fatal damage to the tree that would prevent fruits from being harvested in the future.	Develop a device that does not harm oil palm trees.	A device must be developed that does not harm the oil palm tree and cause it to stop producing fruit.
Prototype could harvest unripe fruit.	If the prototype does not have a way of detecting whether fruit is ripe, unripe fruit may be harvested accidentally.	Develop a device that can discern ripe oil palm fruit.	Any prototype constructed must have a way for the user to discern if an oil palm fruit bunch is ripe before harvesting it.

**Table 3: Descriptions of Long-Term Threats and Opportunities**

Threat	Threat Description	Opportunity	Opportunity Description
Harvesters will continue to be endangered.	Workers will continue to risk their lives climbing trees that are 40-feet tall.	Harvesters will have a safer work environment.	A harvesting device will allow workers to remain on the ground when harvesting oil palm fruit.
Palm oil prices will continue to increase.	As labor costs inevitably increase over time, the cost of palm oil to consumers will increase.	Decrease palm oil prices by increasing harvesting efficiency.	A harvesting device will allow workers to harvest fruit more efficiently and help lower labor costs, which will prevent the consumer from paying higher palm oil prices.
Harvesting methods do not change.	Current harvesting methods will not change and oil palm fruit will continue to be harvested in an inefficient manner.	Ability to revolutionize the oil palm harvesting industry.	A proof-of-concept prototype would allow the oil palm industry to realize that the harvesting process's efficiency can be improved.
Oil palm fruit harvesting efficiency research decreases.	Harvesting efficiency research might decrease if a successful prototype is not constructed.	Oil palm fruit harvesting efficiency research increases.	Research into ways to improve a constructed prototype might increase.

### **2.1.3 Project Stakeholders and Team Organization**

The project's sponsor is Dr. Okenwa Okoli, who is the Chair of the IME department at the FAMU-FSU College of Engineering. The IME department is providing the funding for this project. Dr. Okoli informs the team of any prototype's functional requirements and is the project's main stakeholder. The team has weekly meetings with Dr. Okoli to discuss the project's progress. Since this project also involves the Department of Mechanical Engineering (ME) and the Department of Electrical and Computer Engineering (ECE), Dr. Nikhil Gupta and Dr. Jerris

Hooker, supervisors of each department's respective senior design courses, are also project stakeholders. Furthermore, Ms. Margaret Scheiner and Mr. Ryan Adams, the IME senior design Teaching Assistants, are also stakeholders in this project. The FAMU-FSU College of Engineering, IME, ME, and ECE departments are also stakeholders in this project. Finally, the team is also a stakeholder in this project, in order to ensure the project is completed.

The team's hierarchy is depicted in Figure 5 . A discipline leader is one that is responsible for that discipline's segment of the entire project. The team reports to Dr. Okoli, the project's sponsor. Gabriel Diez was elected as the current Phase Leader, as well as the historian who is responsible for taking and maintaining audio recordings of each team meeting. The team required an ME Phase Leader, because the actual phase require to manage the technical aspects of the project. Matthew Gerstenblitt was elected as the IME Lead, because he has experience working in research and development, as well as project management skills. Matthew was also elected the team's parliamentarian for team contract purposes. Maria Vetencourt was elected as the Business Analyst, because she is also a business management major and has experience analyzing the business applications of technical projects. Enrique Gonzalez was elected the team's Safety Inspector, because he has experience working in machine shop management, as well as supervising manufacturing and job shop production lines. Enrique is aware of the risks involved in machining parts and constructing prototypes. Patrick was elected the team's Material Analyst, because he has experience with automobiles and is currently taking a graduate technical elective on vehicle design. Alberto was elected as the ECE Lead, because he has extensive leadership experience in managing individuals. Alberto is also our Secretary, who is responsible for taking and uploading the group's meeting minutes to the Blog and File Exchange on

Blackboard. Finally, Derek was elected as the group's webmaster, because he is a computer engineering major with HTML, CSS, and JavaScript experience.

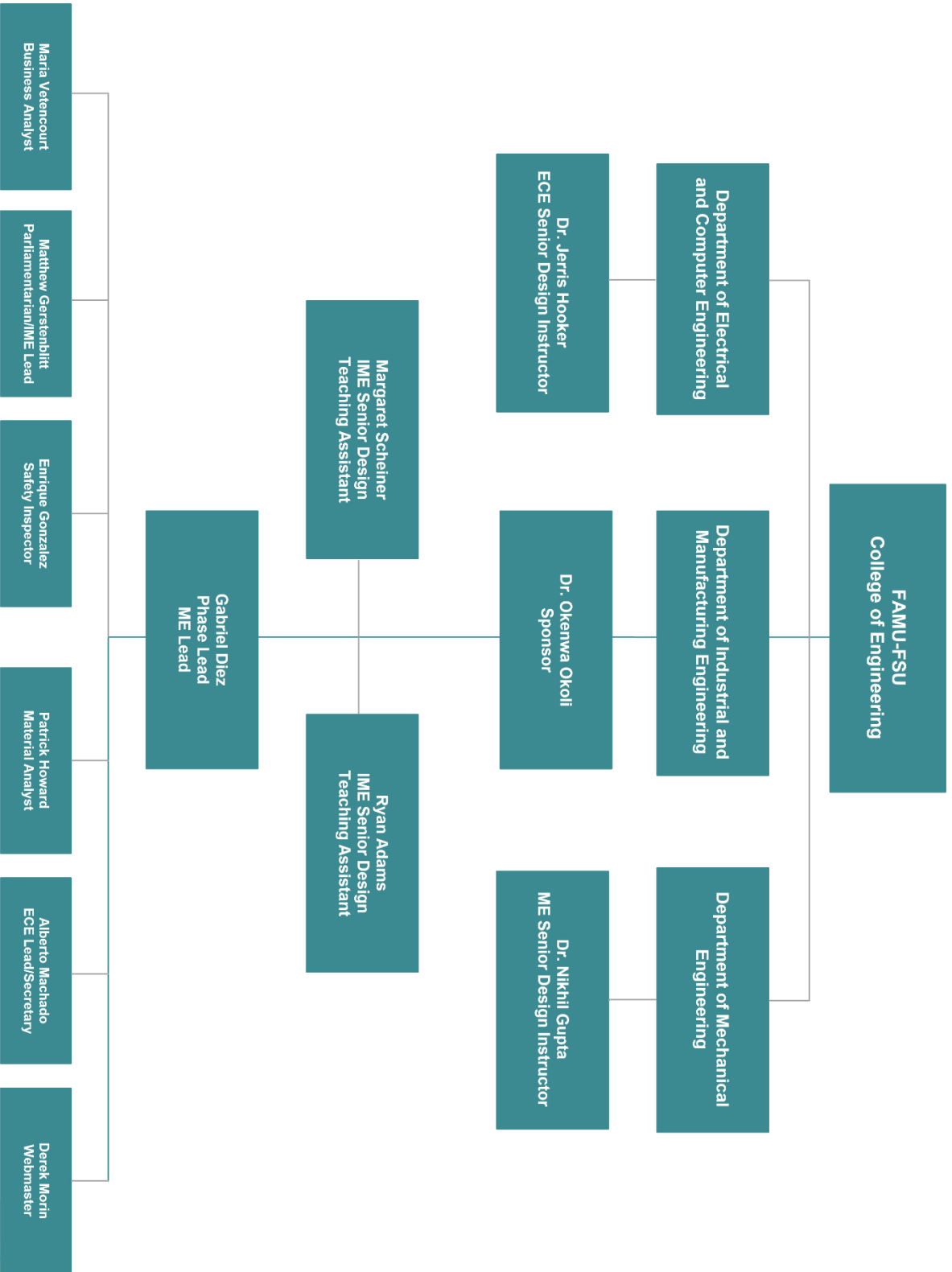

Figure 5: Team Organization Diagram

## **2.2 Approach**

### **2.2.1 Scope**

The scope of this project focuses mainly on developing an electromechanical device to harvest oil palm fruit. In order to construct such a device, the group will research oil palm trees and fruit, as well as current oil palm fruit harvesting methods. Once this research is completed, the team will brainstorm electromechanical design ideas that are consistent with the sponsor's requirements discussed in Section 3.1. Once a design is selected that meets all of the sponsor's criteria, the group will design a prototype utilizing PTC Creo Parametric software and analyze its functionality. Based on the results of the team's analysis, the prototype will be optimized to harvest fruit in the shortest possible amount of time. Finally, documentation will be created that will instruct workers how to operate the device. However, there are several items that are outside the scope of this project. The team is not required to market the product to potential buyers, but only design a device that could be sold by the sponsor. Furthermore, optimizing the production of the designed device is also outside the scope of this project. Finally, the team is not required to obtain feedback from harvesters using the device, because the team will be unable to transport the device to any potential users.

Since the Class of 2015's team was not able to meet Dr. Okoli's requirements successfully, most of the prototype's components were discarded. Only assorted small parts remain from the device. Therefore, an entirely new design is required. Since the team is still able to access the Class of 2015's reports and documentation, their failures should be able to be avoided in this project.

After referencing the Class of 2012's report [6], the Class of 2014's report [13], and the Class of 2015's report [9], the team learned that there are two design approaches to improve the



oil palm fruit harvesting process. The first is a ground-based system that extends from the ground to the top of the tree and cuts the fruit bunches. This has the benefit of being simpler and more feasible to design and build, as well as being less expensive to sell. (It is possible that a different design approach may be conceived when discussing improvements to this design.) The second approach involves designing a system that uses the tree for support and autonomously climbs it to **reach** the fruit. While this would probably be lighter, easier to operate, and transport, it is more complicated and may not be feasible to finish within the time and budget constraints provided.

This year's goals will consist of one of two approaches. The first approach would be to design and build a subsystem for the Class of 2015's prototype and develop a design for the finished prototype for following years to complete. Some examples of this approach include a robotic arm with a cutter and a tree climbing mechanism. The second approach would consist of a proof-of-concept prototype to demonstrate that the design concept is feasible, but it would still need to be improved by succeeding years. Regardless of the approach selected, the team will still have a prototype constructed and delivered by the end of the Control Phase.

The scope of this project has been defined through meetings with the sponsor, and the team will continue to have weekly meetings with the sponsor throughout the entire project. Dr. Okoli will notify the team if the scope of the project needs to be changed, based on the team's feedback and progress.

### ***2.2.2 Assumptions and Constraints***

Since oil palm trees require a tropical rainforest climate to grow [11] and there are no oil palm trees in Tallahassee, Florida, there are many assumptions that must be made regarding the

trees. These assumptions inevitably constrain how any harvesting mechanism can be designed. These constraints provide the project with the direction and necessary standards that must be met before it can be considered completed. Based on conversations with the project’s sponsor and the Class of 2015’s documentation [9], a series of assumptions and their corresponding constraints for the project are listed in Table 4 [2], [9], [11].

**Table 4: Project Assumptions and Constraints [2], [9], [11]**

<b>Assumptions</b>	<b>Constraints</b>
Oil palm trees grow 40-feet high [9].	The mechanism must be capable of reaching a height of 40 feet.
Oil palm plantations have very rough ground and very soft soil.	The device must be lightweight and maneuverable.
Trees are planted approximately 30 feet apart over vast acres of land [9].	The design must be easily portable.
Oil palm trees are grown in a tropical rainforest climate that is prone to high heat and heavy rainfall [2].	The mechanism must be heat and water resistant.
Oil palm trees are grown in very poor regions of the world.	The device must be inexpensive and have a maximum selling price of \$2,000.
Users of any device are unlikely to have experience with sophisticated electromechanical systems.	The prototype must be easy to use.
Any design must lower the cost of harvesting oil palm fruit.	The number of users must be minimized. Two users are allowed to move the device from a truck to the ground, but only one user is allowed to operate and move the machine on the ground of the plantation.
Oil palm fruit weigh 40–60 pounds [2].	Any design must be able to be operated from a safe distance.

### **2.2.3 Deliverables**

Table 5 lists all items the team will deliver by the end of this project and accounts for the ECE, IME, and ME departments' requirements. The dates for phases other than the Define Phase and Measure Phase are subject to change.

**Table 5: Project Deliverables**

<b>Deliverable</b>	<b>Due Date</b>
<b>Define Phase</b>	
Define Phase Gate Review Report	October 20, 2015
Define Phase Gate Review Presentation	October 20, 2015
Risk Assessment	October 20, 2015
Define Phase Peer Evaluation Forms	October 20, 2015
<b>Measure Phase</b>	
Technical Poster 1 Draft	November 24, 2015
Initial 3D CAD* Renderings	December 1, 2015
Initial Bill of Materials	December 1, 2015
Initial Mechanical Analysis	December 1, 2015
Measure Phase Gate Review Report	December 1, 2015
Measure Phase Gate Review Presentation	December 1, 2015
Measure Phase Peer Evaluation Forms	December 1, 2015
Final Technical Poster 1	December 3, 2015
Project Completion Form	December 4, 2015
<b>Analyze Phase</b>	
Analyze Phase Gate Review Report	January 29, 2016
Analyze Phase Gate Review Presentation	January 29, 2016
Analyze Phase Peer Evaluation Forms	January 29, 2016
Final 3D CAD Renderings	January 29, 2016
Final Mechanical Analysis	January 29, 2016
Final Bill of Materials	January 29, 2016
<b>Improve Phase</b>	
Improve Phase Gate Review Presentation	February 26, 2016
Improve Phase Peer Evaluation Forms	February 26, 2016
<b>Control Phase</b>	
Technical Poster 2	March 31, 2016
Control Phase Gate Review Report	March 31, 2016
Final Design Specifications	March 31, 2016
Prototype Operating Instructions	March 31, 2016
Working Prototype	March 31, 2016
CD of All Deliverables	March 31, 2016
Control Phase Peer Evaluation Forms	March 31, 2016
<b>Post-Control Phase</b>	
Business Analysis Report	April 12, 2016
Business Analysis Presentation	April 12, 2016
Business Analysis Peer Evaluation Forms	April 12, 2016
Project Completion Form	April 12, 2016

\*CAD refers to computer-aided design software, such as AutoCAD.

In Table 5, the term “initial” refers to the design outlined by the Measure Phase, which is a preliminary model that is intended to meet all baseline performance requirements. The term “final” applies to the Analyze Phase design.

### 2.2.4 SIPOC Diagram

To help visualize the project’s process, a Supplier-Inputs-Process-Outputs-Customers (SIPOC) diagram was created and is depicted in Figure 6.

Oil Palm Fruit Harvesting				
Suppliers	Inputs	Process	Outputs	Customers
Vendors	Materials and parts	1. Define customer's requirements	End of Phase Reports and Presentations Risk Assessment CAD Drawings 3D CAD Renderings Mechanical Analysis Technical Poster 1 Project Completion Forms Working Prototype Technical Poster 2 Final Design Specifications Final Working Product Prototype Operating Instructions	Dr. Okoli          Oil Palm Harvesters
Dr. Okoli	Project budget	2. Create design that meets all requirements		
Written project information	Project scope	3. Select final design		
		4. Order materials		
	Project parameters	5. Assemble prototype		
		6. Analyze prototype		
		7. Improve prototype		
		8. Finalize design and operating procedures		

Figure 6: SIPOC Diagram

The SIPOC diagram depicted in Figure 6 displays the suppliers, inputs, process, outputs, and customers for the oil palm fruit harvesting device. The suppliers providing resources for the project are our sponsor, Dr. Okoli, vendors from which we will obtain parts to build the prototype, and all written information regarding the project provided to the team. Dr. Okoli provides the project budget to obtain all needed items to complete the project, such as the parts needed to build a working prototype. Any parts needed will be ordered from a vendor and then assembled by the team. Thus, the project’s inputs include materials and parts, the project’s budget, the project’s scope, and the project’s parameters. The process column in Figure 6 lists the high-level steps necessary for completing the project. Outputs for this project depicted in Figure 6 include, but are not limited to, each phase’s respective report, presentation and peer

evaluation forms, as well as the final prototype's operating instructions. Computer-aided designs are also used to develop an oil palm fruit harvesting device design and perform a mechanical analysis on all parts that will be used. Finally, the customers that will benefit at the conclusion of this project include the sponsor, Dr. Okoli, as well as oil palm plantation owners and workers. The plantation owners will be able to increase the output of their oil palm crops, while the harvesters will benefit from a safer and more efficient workplace.

### **3. Defining Customer and Technical Requirements**

#### **3.1 Customer Requirements**

According to the sponsor, the purpose of this project is to improve the method by which palm fruits are harvested. Currently, this involves a laborer climbing a 40-foot tree and cutting each fruit manually [2]. Dr. Okoli wishes to improve the productivity and safety of this process by using an electromechanical device. The customer's requirements were converted into a diagram and are depicted in Figure 7. Descriptions of each requirement are given in Table 6.

# Voice of the Customer

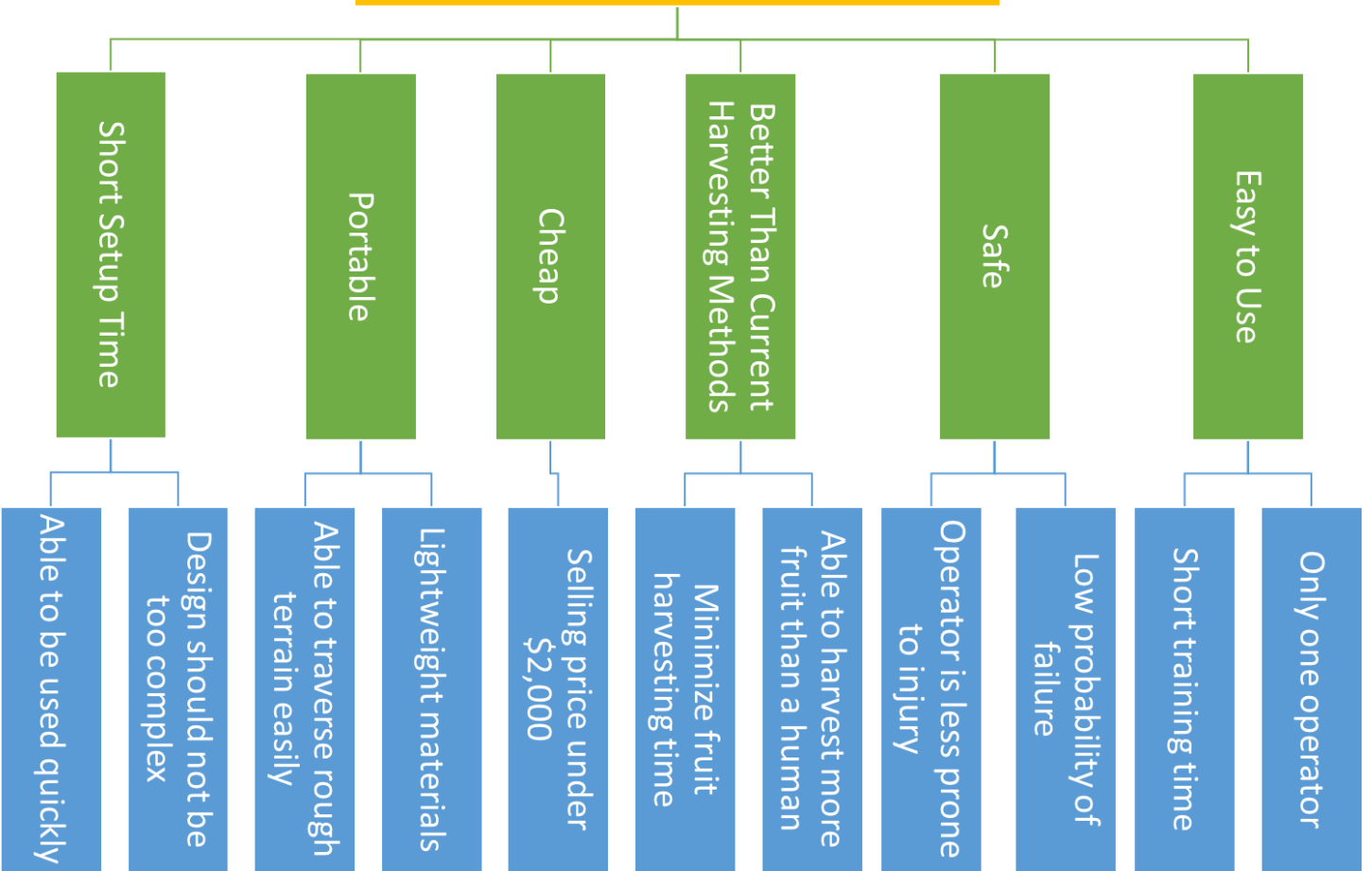

Figure 7: Voice of the Customer Diagram

**Table 6: Descriptions of Customer Requirements**

Customer Requirement	Description
Easy To Use	The device should be able to be used by current oil palm fruit workers that have limited skills [2]. Since each tree is currently harvested by only one worker, any machine that requires two operators would immediately double the cost of production, by doubling the labor costs per tree. Therefore, any design that requires more than one person to operate it is not acceptable to our sponsor.
Safe	Since the current process is dangerous [2], worker safety must be improved. This includes ensuring the design is safe and that the operator does not risk injury from the device.
Better Than Current Harvesting Methods	Since the purpose of this project is to improve a process that is currently performed by humans, it is critical that the device be superior to a human worker. This includes factors such as fatigue. A well-designed prototype is only limited by its power source. Therefore, the machine must be able to reach the top of the tree faster and harvest more fruit than a human can in the same amount of time.
Low Cost	Since the regions where the device is expected to be used are generally very poor, the sponsor specified that the final machine cannot have a sale price of more than \$2,000.
Lightweight/Portable	Since oil palm plantations occupy vast stretches of land [2], portability is extremely important. Otherwise, the time to go from tree to tree would increase, causing a decrease in productivity. One simple way to increase portability would be to make the design as lightweight as possible.
Short Setup Time	Since a human worker can immediately grab onto the tree and start climbing, the time for the design to be ready to operate must be minimized. Otherwise, it cannot be considered a superior alternative to current harvesting methods.



### 3.2 Technical Requirements

The technical requirements needed to meet the customer's requirements are described in Table 7.

**Table 7: Descriptions of Technical Requirements**

Technical Requirement	Description
System Weight	Minimizing the weight would make the device more portable and would make any forces acting on it cause less severe damage. From an efficiency standpoint, a lightweight design would theoretically use less material.
Modular	A modular design would improve the device's portability and make it easier to ship. Furthermore, it would lower the maintenance costs and selling price of the design.
Strength of Materials	Since the machine will be encountering heavy fruit bunches at heights of up to 40-feet, the strength of its materials must be high in order for it to survive any accidents that may occur.
Energy Capacity	Whether the energy source of the machine is stored chemically with gasoline or electrically with a battery, it must be able to last for an entire day of harvesting.
Shielded Electronics	Since the electronics are highly vulnerable to both water and impact, it is crucial that any design protects them from both of these factors.

Fruit Visibility	Oil palm fruit ripen at different rates [2]. Therefore, not all oil palm fruit bunches may be ready to be harvested at the same time. A human climber can easily determine which fruit bunches must be cut and which bunches should remain. The oil palm fruit harvesting machine must be able to either determine which fruit bunches are ready to be cut or allow a human operator to make the decision from the ground.
Electromechanical Components	While electromechanical components may make the achievable goal easier by means of programmed intelligence and endurance, they add a level of delicacy and expense to the design.
Setup Time	Since a human climber can immediately grab onto the tree and start climbing, the time for the design to be ready to operate must be minimized. Otherwise, it cannot be considered to be a superior alternative to the current harvesting methods.
Autonomy	More autonomy would require less human input and would decrease the amount of skill necessary to operate the system. Theoretically, a completely autonomous system would eliminate the need for workers to monitor the device. However, that assertion is currently outside the scope of this project.
User Control System	As the control the user has over the system increases, the number of individuals necessary to operate the system decreases. Therefore, the number of controls should reflect the goal of requiring only one operator.
Harvesting Time	The time for the machine to arrive at a tree and harvest a fruit bunch must be less than that of a human, in order to improve productivity.
Training Time	It would be ideal for this design to require as little training as possible, to allow individuals with minimal skill to be able to operate it. Additionally, training a worker takes time and costs money and should therefore be avoided as much as possible.

In order to complete a design that meets the goal of improving this process, the technical requirements from Table 7 were inputted into the house of quality discussed in Section 3.5.

### **3.3 Current Harvesting Process**

The process being improved is oil palm fruit harvesting. The purpose of studying this process is to improve the poor methods currently used. When workers first arrive at the plantation, they receive their tree climbing and cutting tools. Oil palm fruit harvesters then walk through oil palm plantations looking for a ripe fruit bunch. A typical worker walks 7–10 acres per day [2]. These bunches are identified if a tree has loose fruit on the ground or any fruit bunches visible have a red or brown color to them. After the worker cuts a fruit bunch, it must be moved to a designated collection point on the plantation. Cutting fruit from trees less than 20-feet tall is not an issue, because there are cutting tools that exist for performing this task [2]. However, cutting fruit from trees that are 20-feet to 40-feet high presents a problem. If the fruit bunches are not visible from the ground, a worker may climb a tree and find that no fruit bunches are ready to be harvested. Even if a worker does climb the tree successfully, the worker has a high risk of injury when ascending and descending the tree [2]. For this process to function properly, there must be unskilled laborers willing to climb oil palms. The current harvesting process for trees that are 20-feet to 40-feet tall (hereinafter referred to as “tall trees”) is depicted in Figure 8 [2]. The goal of this project is to allow workers to determine if fruit bunches are ready to be harvested and allow workers to use an electromechanical device to harvest the fruit, from the ground.

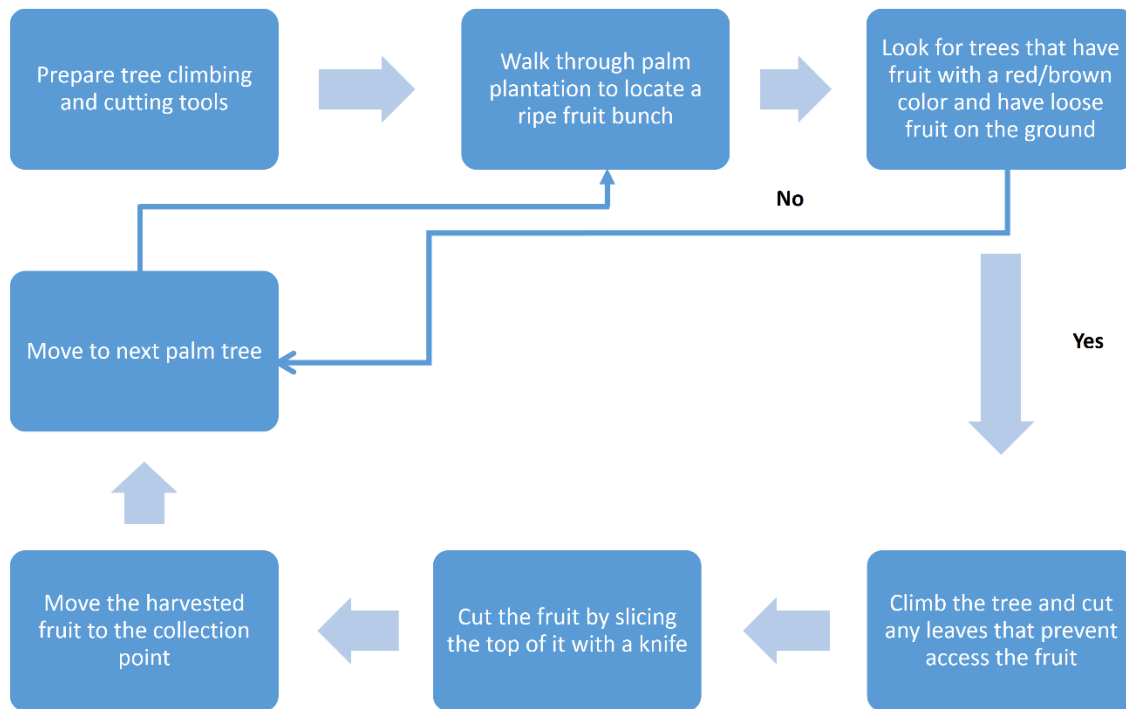

**Figure 8: Current Oil Palm Fruit Harvesting Method for Tall Trees [2]**

The process depicted in Figure 8 works properly when workers are able to identify a tree that has ripe fruit bunches from the ground, ascend the tree, cut the fruit, descend the tree, and then move the fruit to the designated collection point. However, there is a major flaw with this process. A worker could climb tall trees for an entire day and not find any ripe fruit bunches to be cut. This is inefficient and puts the worker in unnecessary danger. Allowing workers to determine if oil palm fruits are ripe and then harvest them from the ground would significantly improve the process. An Ishikawa diagram of the issues with the current harvesting process is depicted in Figure 9.

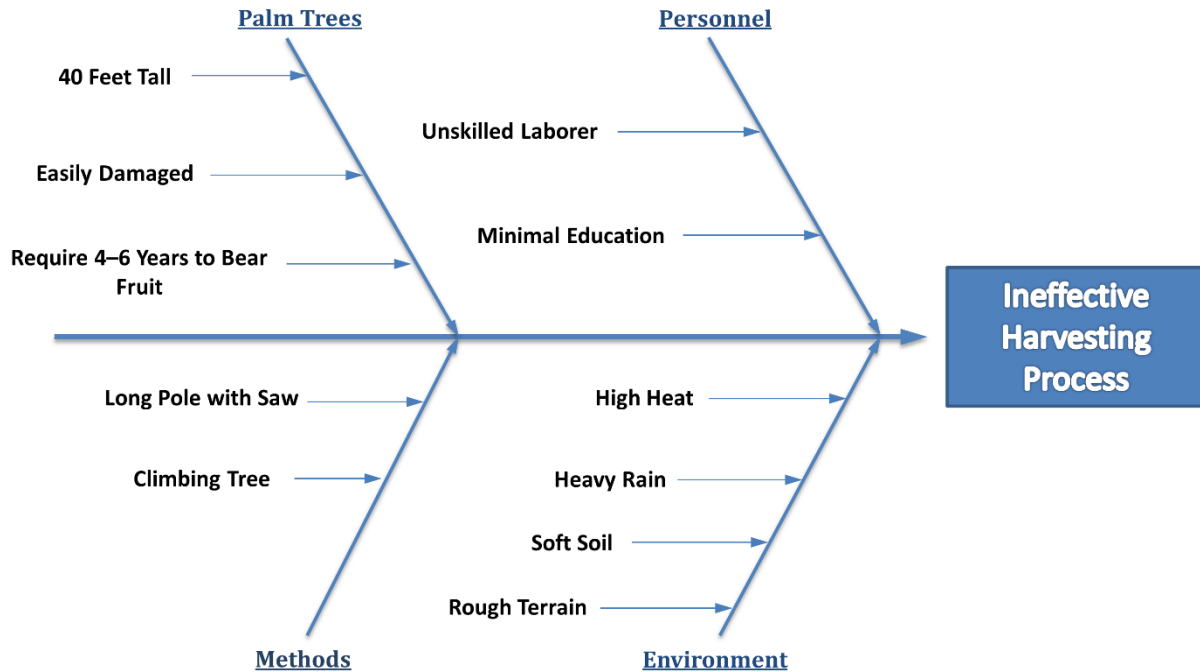

Figure 9: Ishikawa Diagram of the Palm Harvesting Process [2]

Figure 9 helps direct the project by highlighting important aspects of the current harvesting methods. These trees can easily be damaged, grow to a maximum of approximately 40 feet, and require four to six years to bear fruit. Therefore, any system must be able to reach 40 feet and not cause harm to the trees. Considering the personnel operating any assembled device will be used to manually ascending and descending oil palm trees, the device must be easy to use. Analyzing current methods enables the team to see the advantages and disadvantages associated with these methods. Finally, understanding the climate of oil palm tree plantations allows the team to ensure any finalized design will have a long life cycle.

### 3.4 Need for an Electromechanical Harvesting Device

The current oil palm fruit harvesting process involves a worker climbing a tree and manually cutting ripe fruit bunches. In addition to the dangers associated with climbing 40 feet numerous times per day, it is exhausting work that limits the number of trees a worker can climb

[2]. Since no devices currently exist to assist workers harvesting oil palm fruit from tall trees, the team's solution is to create an electromechanical system that would eliminate the risk a worker faces when harvesting fruit bunches. Also, the device would be able to ascend the height of the tree with speed and ease, thus increasing the number of oil palm fruits that one worker could harvest. With a greater number of oil palm fruit harvested, oil palm plantation owners would be able to increase their profits, and laborers would experience a safer and more efficient work environment.

### **3.5 House of Quality**

A house of quality was created to assist with this project and is depicted in Figure 10. The house of quality is important, because it allows the customer's requirements to be converted into technical requirements and shows the team's prioritization of tasks [14]. The team's house of quality was constructed after meeting with the project's sponsor and then brainstorming any technical requirements that may be needed for future designs.

Customer requirements (also known as the demanded qualities) are listed on the left side of Figure 10 and were discussed in Section 3.1. These functional requirements for the final prototype were divided into the following categories: Easy to Use, Performance, and Cost. In order to meet these customer requirements, the team devised several quality characteristics (also known as technical requirements) that are related to the customer's demands. These technical requirements were divided into the categories Design and Operation, shown in Figure 10 and were discussed in Section 3.2. The Customer Importance column assigns a quantitative value to each of the customer's demands. A score of "1.0" denotes that it is the least important, while a score of "9.0" denotes that it is the most important; these rankings were determined based on the team's meetings with the sponsor. More than one of the customer's demands can receive the

same ranking. The Organizational Difficulty row in Figure 10 utilizes the same numerical scale, but denotes the difficulty of the team accomplishing each of the technical requirements.

### 3.5.1 Relationships

The cells in the center of Figure 10 represent correlations among customer requirements (each row) and technical requirements (each column). Each cell may have a “weak,” “medium,” “strong,” or no relationship between its respective customer and technical requirement. An explanation of the correlations of each customer requirement to technical requirements is given in their respective table.

**Table 8: Explanation of "One Operator" Relationships**

Technical Requirement	Explanation
System Weight	A lightweight system would allow one individual to operate it.
Modular	A modular design would allow one operator to assemble the system.
Electromechanical Components	Fewer electromechanical components would allow one operator to utilize the system, because fewer controls would be needed.
Autonomy	A system that requires minimal user control would allow one operator to use it.
Number of User Controls	Fewer user controls would allow only one operator to utilize the system.

**Table 9: Explanation of "Lightweight/Portable" Relationships**

Technical Requirement	Explanation
System Weight	A lighter system would allow any developed prototype to be portable.
Modular	A modular design would allow a prototype to be disassembled and easily transported.
Strength of Materials	Using stronger materials may increase the weight of the system.
Energy Capacity	Using a larger power source may increase the weight of the system.
Shielded Electronics	Ensuring the electronics are shielded from the environment may slightly increase the weight of the system.
Electromechanical Components	Adding more electromechanical components would add more weight to the system.
Setup Time	A portable system may require some assembly before use.
Number of User Controls	More controls may slightly increase the weight of the system.



**Table 10: Explanation of "Better than Current Harvesting Methods" Relationships**

Technical Requirement	Explanation
Modular	A modular design may increase the safety of the workers, because they may not have to carry an open blade.
Energy Capacity	A machine does not experience fatigue like a human does.
Shielded Electronics	Any electronics would not be as susceptible to the environment as a human would be.
Fruit Visibility	The fruit must be visible to the operator on the ground.
Electromechanical Components	Electromechanical components do not experience fatigue like humans do.
Setup Time	The system should take at most as much time to setup as it currently takes a human to manually climb a tree.
Autonomy	A more autonomous system would decrease the amount of human interaction needed.
Number of User Controls	Fewer controls would help improve the current manual process.
Harvesting Time	Harvesting time should be no greater than the time it takes a human to cut a fruit bunch and descend the tree.
Training Time	The time it takes to train current operators to use any prototype should be minimized.

**Table 11: Explanation of "Waterproof" Relationships**

Technical Requirement	Explanation
Shielded Electronics	Electronics must be shielded from the environment to be waterproof.
Fruit Visibility	Making the electromechanical components waterproof should not influence fruit visibility.
Electromechanical Components	Electromechanical components must be waterproof to ensure that they remain functional.
Autonomy	If the system is not waterproof, the components that allow the device to be autonomous may fail.
Training Time	Making components waterproof may require additional time to train operators how to maintain the device.

**Table 12: Explanation of "Durable" Relationships**

Technical Requirement	Explanation
Modular	Assembling and disassembling the prototype may cause more wear over time.
Strength of Materials	A durable design must have the strongest materials possible, while also satisfying other customer requirements.
Energy Capacity	A larger energy capacity would allow the device to operate longer in the field.
Shielded Electronics	Electronics must be shielded from the environment to ensure that the system functions properly.
Electromechanical Components	Wear from electromechanical components may marginally decrease the durability of the system.
Autonomy	Autonomous systems are more complex and may be more likely to fail.
Number of User Controls	A greater number of user controls may result in more frequent component replacements.

**Table 13: Explanation of "High Capacity Power Source" Relationships**

Technical Requirement	Explanation
System Weight	A larger capacity power source may require a heavier battery and increase the system's weight.
Energy Capacity	A high capacity power source would ensure a large energy capacity.
Autonomy	A more autonomous system may require a larger power source to operate.
Number of User Controls	More user controls may require a larger power source to operate.
Harvesting Time	A faster harvesting time may require a larger power source to operate.

**Table 14: Explanation of "Below \$2,000" Relationships**

Technical Requirement	Explanation
System Weight	A sale price of \$2,000 may limit the type of materials that can be used and require less expensive, but heavier materials.
Modular	A modular design may use fewer large pieces and thus decrease the production cost.
Strength of Materials	Strong materials must be selected within the \$2,000 sale price.
Shielded Electronics	The cost of shielding all electronics must have a minimal effect on the production cost of the prototype.
Fruit Visibility	A high-resolution camera to allow the operator to see the fruit bunches from the ground will be more expensive than a low-resolution one.
Electromechanical Components	The minimum amount of electromechanical components should be used to reduce costs.
Autonomy	\$2,000 may limit the possible autonomy of the system to remain within the target production cost.
Number of User Controls	The minimum number of user controls should be used to reduce costs.

**Table 15: Explanation of "Low Maintenance Expenses" Relationships**

Technical Requirement	Explanation
System Weight	Heavier materials may cause the system to experience more wear and require more frequent repairs.
Modular	A modular system allows pieces of the system to be replaced, instead of requiring the user to purchase an entirely new device.
Strength of Materials	Stronger materials may result in components being replaced less frequently.
Shielded Electronics	Electronics that are shielded from the environment would have a lower replacement frequency.
Electromechanical Components	Using reliable electromechanical components may decrease their replacement frequency.
Autonomy	A more autonomous system may be more likely to require more frequent servicing.
Number of User Controls	A fewer number of user controls may result in less frequent maintenance.

### **3.5.2 Correlations**

The cells at the top of Figure 10 depict correlations between the Quality Characteristics/Technical Requirements. Each cell can have a strongly negative correlation, a moderately negative correlation, no correlation, a moderately positive correlation, or a strongly positive correlation. An explanation of the correlations for each technical requirement is provided in their respective table.

**Table 16: Explanation of "System Weight" Correlations**

Technical Requirement	Explanation
Strength of Materials	Higher strength materials are generally heavier, which increases the system's weight.
Energy Capacity	Higher capacity batteries are normally heavier than lower capacity ones.
Electromechanical Components	Decreasing the number of electrochemical components would decrease the system's overall weight.
Setup Time	Decreasing the system weight would result in lighter parts that require less time to assemble.

**Table 17: Explanation of "Modular" Correlations**

Technical Requirement	Explanation
Electromechanical Components	A modular design may require fewer electromechanically components to be used, so that it can be easily disassembled.
Setup Time	A modular system would be able to be assembled quickly.
Training Time	A modular system would allow the operator to learn how the system works by using it.

**Table 18: Explanation of "Strength of Materials" Correlations**

Technical Requirement	Explanation
System Weight	Higher strength materials are generally heavier, which increases the system's weight.

**Table 19: Explanation of "Energy Capacity" Correlations**

Technical Requirement	Explanation
System Weight	Higher capacity batteries are normally heavier than lower capacity ones.

**Table 20: Explanation of "Shielded Electronics" Correlations**

Technical Requirement	Explanation
Electromechanical Components	Using fewer electromechanical components would require less space to shield them from the environment.

**Table 21: Explanation of "Fruit Visibility" Correlations**

Technical Requirement	Explanation
Harvesting Time	A higher resolution camera would allow the user to accurately cut fruit bunches, thus reducing harvesting time.
Training Time	Poor fruit visibility will require more time to train an employee to use the system.

**Table 22: Explanation of "Electromechanical Components" Correlations**

Technical Requirement	Explanation
System Weight	Fewer electrochemical components will decrease the system's overall weight.
Shielded Electronics	Using fewer electromechanical components would require less space to shield them from the environment.
Setup Time	Fewer electromechanical components may decrease setup time.
Autonomy	More electromechanical components may have to be used to make the system more autonomous.
Number of User Controls	Using more electromechanical components may require increasing the number of user controls.
Training Time	Increasing the number of electromechanical components may require a user to spend more time with the system to be able to use it.

**Table 23: Explanation of "Setup Time" Correlations**

Technical Requirement	Explanation
System Weight	Decreasing the system weight would result in lighter parts that require less time to assemble.
Modular	A modular system would be able to be assembled quickly.
Electromechanical Components	Fewer electromechanical components may decrease setup time.
Training Time	Increasing the number of electromechanical components may require a user to spend more time with the system to be able to use it.

**Table 24: Explanation of "Autonomy" Correlations**

Technical Requirement	Explanation
Electromechanical Components	More electromechanical components may have to be used to make the system more autonomous.
Number of User Controls	A more autonomous the system would require less user control.
Training Time	A more autonomous the system, would require less time to train an individual to use it.

**Table 25: Explanation of "Number of User Controls" Correlations**

Technical Requirement	Explanation
Electromechanical Components	Using more electromechanical components may require increasing the number of user controls.
Autonomy	A more autonomous the system would require less user control.
Harvesting Time	A greater number of user controls may require the operator to spend more time harvesting fruit bunches.
Training Time	A greater number of user controls may require the operators to spend more time learn how to use the device.

**Table 26: Explanation of "Harvesting Time" Correlations**

Technical Requirement	Explanation
Fruit Visibility	A higher resolution camera would allow the user to accurately cut fruit bunches, thus reducing harvesting time.
Number of User Controls	A greater number of user controls may require the operator to spend more time harvesting fruit bunches.

**Table 27: Explanation of "Training Time" Correlations**

Technical Requirement	Explanation
Modular	A modular system would allow the operator to learn how the system works by using it.
Fruit Visibility	Poor fruit visibility will require more time to train an employee to use the system.
Electromechanical Components	Increasing the number of electromechanical components may require a user to spend more time with the system to be able to use it.
Setup Time	Increasing the number of electromechanical components may require a user to spend more time with the system to be able to use it.
Autonomy	A more autonomous the system, would require less time to train an individual to use it.
Number of User Controls	A greater number of user controls may require the operators to spend more time learn how to use the device.

### **3.5.3 Calculations**

There are several values that were calculated from Figure 10. The Weighted Importance is calculated for each Quality Characteristics/Technical Requirements column by taking the relationship symbol value for each related customer requirement row and multiplying it by its corresponding customer importance value. These computed values are then summed. For



example, the Weighted Importance of the “Training Time” technical requirement was calculated using the information from Table 28.

**Table 28: Values Used to Compute the Weighted Importance of the "Training Time" Technical Requirement**

Customer Requirement	Customer Importance Value	Relationship to Technical Requirement	Relationship to Technical Requirement Value
Better than Current Harvesting Methods	8.0	Moderate	3.0
Waterproof	9.0	Weak	1.0

Calculating the Weighted Importance:

$$3(8) + 1(9) = 33.0$$

Using the information from Table 28, the Weighted Importance for the “Training Time” was calculated to be 33.0.

The Relative Importance for each Quality Characteristic/Technical Requirement is calculated by dividing the Weighted Importance of each Technical Requirement by the sum of all the Weighted Importance values and multiplying by 100%. For example, to calculate the Weighted Importance of the “Training Time” Technical Requirement:

Computing the sum of Weighted Importance values:

**Table 29: Weighted Importance Values of Each Technical Requirement**

Quality Characteristic/Technical Requirement	Weighted Importance Value
System Weight	231.0
Modular	228.0
Strength of Materials	138.0
Energy Capacity	172.0
Shielded Electronics	213.0
Fruit Visibility	108.0
Electromechanical Components	255.0
Setup Time	210.0
Autonomy	210.0
Number of User Controls	144.0
Harvesting Time	80.0
Training Time	33.0
Sum	1905.0

Calculating the Relative Importance of the “Training Time” Technical Requirement using the information from Table 29:

$$Relative\ Importance_{Training\ Time} = \frac{Weighted\ Importance_{Training\ Time}}{\sum(Relative\ Importance)} \times 100\%$$

$$Relative\ Importance_{Training\ Time} = \frac{33.0}{1905.0} \times 100\% = 1.7\%$$

Finally, the rank denotes the order of importance for each of the requirements, based on the computed relative importance percentages. A value of “1” indicates the relatively most important requirement, while a value of “12” indicates the relatively least important requirement. From Figure 10, the most important requirement is the electromechanical components.

	Symbol	Meaning	Value
Relationships	△	Weak Relationship	1
	○	Medium Relationship	3
	●	Strong Relationship	9
Correlations	⊗	Strong Negative Correlation	0
	×	Negative Correlation	0
	○	Positive Correlation	0
	●	Strong Positive Correlation	0
Improvement Direction	↓	The Smaller The Better	0
	↑	The Larger The Better	0

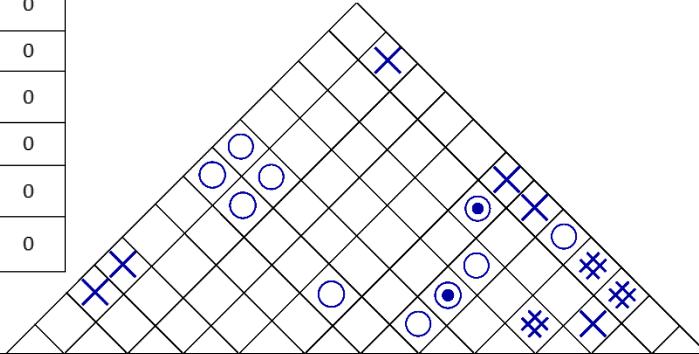

Palm Harvester		Quality Characteristics/Technical Requirements													
		Customer Importance	Design						Operation						
			System Weight	Modular	Strength of Materials	Energy Capacity	Shielded Electronics	Fruit Visibility	Electromechanical Components	Setup Time	Autonomy	Number of User Controls	Harvesting Time	Training Time	
<b>Customer Requirements</b>		↓	↑	↑	↑	↑	↑	↓	↓	↑	↓	↓	↓		
Demanded Quality	Easy to use	One Operator	8.0	●	○					△		●	●		
		Lightweight/Portable	7.0	●	●	○	○	△		●	○		△		
		Better than Current Harvesting Methods	8.0		△		●	△	●	○	●	●	△	●	○
		Waterproof	9.0					●	○	○		△			△
		Durable	7.0		△	●	△	●		△		△	△		
		High Capacity Power Source	8.0	●			●					△	△	△	
		Below \$2,000	9.0	△	●	△		△	△	●		○	○		
		Low Maintenance Expenses	5.0	○	●	●		●		●		○	○		
<b>Organizational Difficulty</b>			9.0	3.0	6.0	5.0	5.0	5.0	7.0	4.0	7.0	3.0	7.0	2.0	
<b>Weighted Importance</b>			231.0	228.0	138.0	172.0	213.0	108.0	255.0	93.0	210.0	144.0	80.0	33.0	
<b>Relative Importance</b>			12.1%	12.0%	7.2%	9.0%	11.2%	5.7%	13.4%	4.9%	11.0%	7.6%	4.2%	1.7%	
<b>Rank</b>			2	3	8	6	4	9	1	10	5	7	11	12	

Figure 10: House of Quality

### **3.6 Work Breakdown Structure**

A work breakdown structure (WBS) was created using the information from Table 5 and is depicted in Figure 11. The purpose of the WBS is to organize the team's work (by phase) into manageable sections. The WBS depicted in Figure 11 is subject to change in future phases.

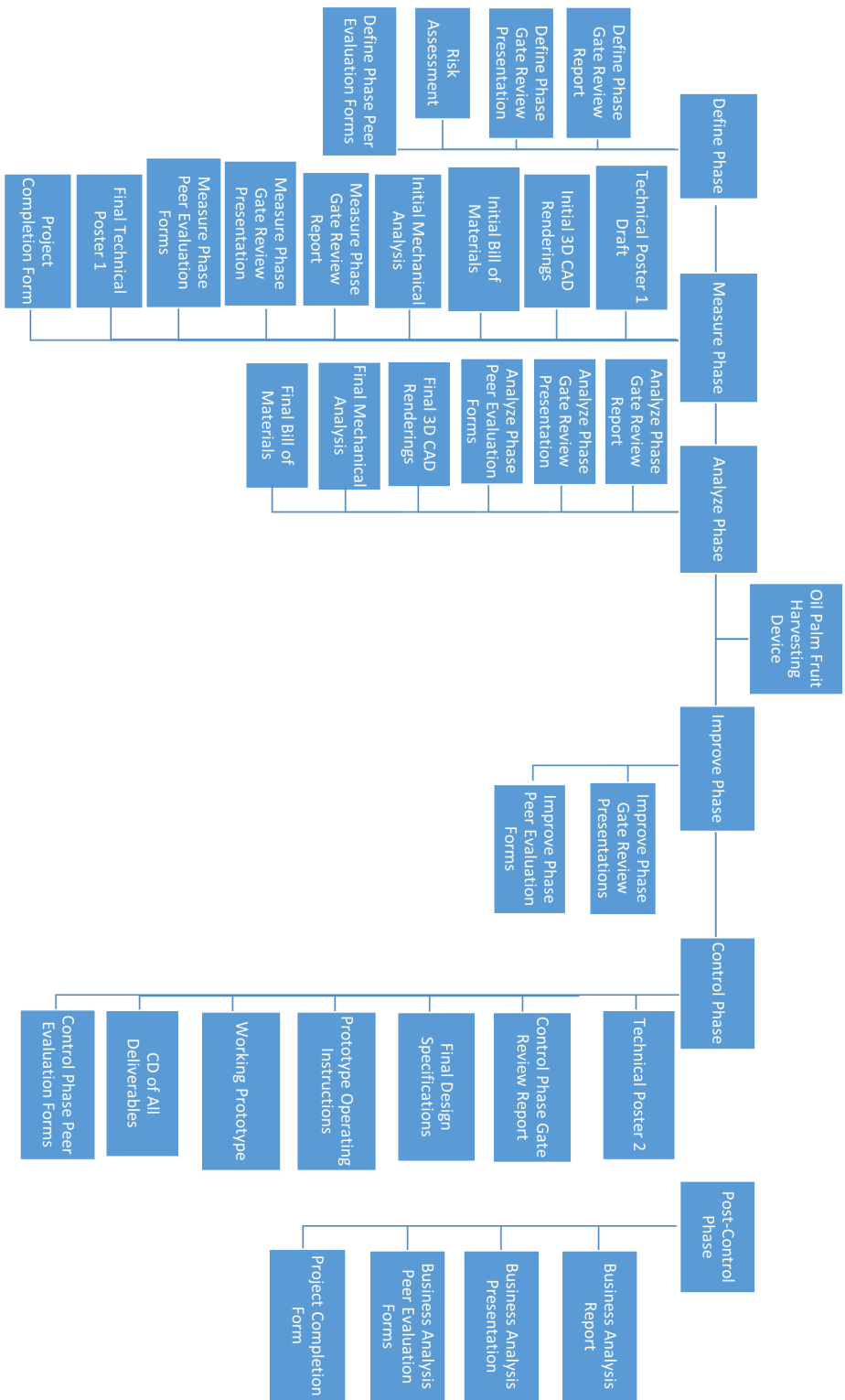

**Figure 11: Work Breakdown Structure**

### 3.7 Responsibility Assignment Matrix

A responsibility assignment matrix (RAM) was created from the deliverables described in Table 5 and is depicted in Table 30. The RAM describes which team members are responsible for each work package and is subject to change in future phases.

**Table 30: Responsibility Assignment Matrix**

Oil Palm Fruit Harvesting Device							
Task/Person	Matthew Gerstenblitt	Gabriel Diez	Patrick Howard	Enrique Gonzalez	Maria Vetencourt	Alberto Machado	Derek Morin
Define Phase Gate Review Report	R	I	A	C	C	A	I
Define Phase Gate Review Presentation	R	A	C	I	C	I	A
Risk Assessment	C	C	I	R	A	C	A
Define Phase Peer Evaluation Forms	R	R	R	R	R	R	R
Technical Poster 1 Draft	A	I	A	C	R	I	C
Initial 3D CAD Renderings	I	A	R	I	I	C	C
Initial Bill of Materials	I	A	I	R	I	C	C
Initial Mechanical Analysis	I	A	R	I	I	C	C
Measure Phase Gate Review Report	A	C	C	I	R	I	A
Measure Phase Gate Review Presentation	A	I	A	C	R	C	I
Measure Phase Peer Evaluation Forms	R	R	R	R	R	R	R
Final Technical Poster 1	A	A	A	R	C	C	I
Project Completion Form	R	I	C	A	I	A	C
Analyze Phase Gate Review Report	C	R	A	A	C	I	I
Analyze Phase Gate Review Presentation	A	A	I	I	C	R	C
Analyze Phase Peer Evaluation Forms	R	R	R	R	R	R	R

Final 3D CAD Renderings	I	R	A	I	I	C	C
Final Mechanical Analysis	I	R	A	I	I	C	C
Final Bill of Materials	I	A	R	I	I	C	C
Improve Phase Gate Review Presentation	I	C	R	I	C	A	A
Improve Phase Peer Evaluation Forms	R	R	R	R	R	R	R
Technical Poster 2	A	C	C	I	A	I	R
Control Phase Gate Review Report	C	A	I	C	A	R	I
Final Design Specifications	A	C	R	I	A	C	I
Prototype Operations Instructions	I	R	C	I	A	A	C
Working Prototype	R	R	R	R	R	R	R
CD of All Deliverables	C	I	A	A	I	C	R
Control Phase Peer Evaluation Forms	R	R	R	R	R	R	R
Business Analysis Report	I	A	I	R	C	C	A
Business Analysis Presentation	A	A	I	C	R	I	C
Business Analysis Peer Evaluation Forms	R	R	R	R	R	R	R
Project Completion Form	A	I	C	C	I	R	A

Code:	Represents:	This Person Is:
R	Responsible	Responsible, the one doing the work
A	Accountable	Accountable, the one expected to justify actions or decisions
C	Consult	To be consulted, one whose expertise may help the one completing the work
I	Inform	To be kept informed, one who does not fit into the preceding three categories

## 4. Selected Design

### 4.1 Previous Design Ideas

#### 4.1.1 Improving the Class of 2015's Design

The Class of 2015's design utilized telescoping poles comprised of Aluminum 6061 with a saw attached at the top of the pole and is depicted in Figure 12 [9].

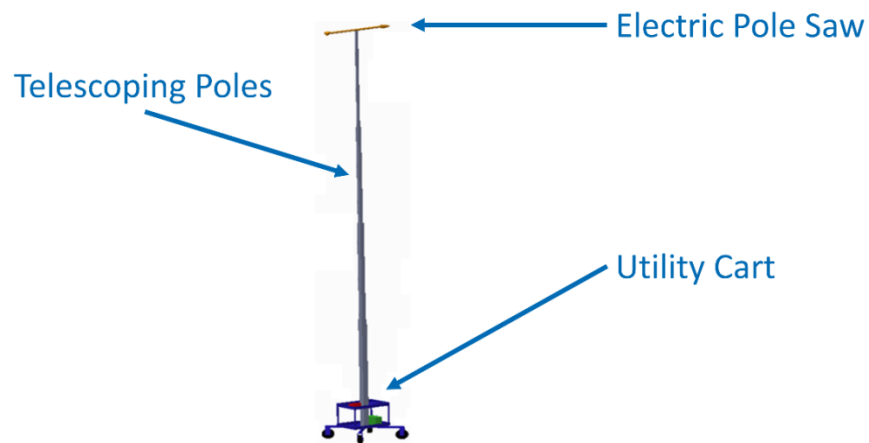

Figure 12: Previous Group's Design [9]

The design depicted in Figure 12 consisted of a pole that was mounted on a manually operated cart with four rugged never-flat wheels protruding from the sides. An electric motor was used to drive a pulley mechanism to extend the pole approximately 40-feet upward. The saw was controlled from the ground by several ropes. While this design proved capable of extending to the required height to harvest the fruit bunches, there were several aspects that prevented it from being an ideal solution. The 40-foot telescoping pole had to be thick enough to resist bending forces. The poles were too heavy to be moved using a small cart and were not able to remain stable when they were extended. Finally, the saw was not securely attached to the poles and the chainsaw blade was dangerously left uncovered [9].



In order to improve this design, a new chassis to hold the pole would need to be designed. The chassis would need to be large enough to ensure the pole remains stable, while also being lightweight enough to be moved by one person. This support structure must also be capable of operating in rough terrain, which may require the construction of a suspension system. Furthermore, the saw located at the top of the pole must be covered when it is not in use, to decrease the risk of injury to the operator. This means that the rope system used to control the saw should be converted to an electronic system, because it is less likely to injure a worker using the device.

#### ***4.1.2 Extended Pole Pruner***

The extended pole pruner concept utilizes an existing device from the landscaping industry—an extendable gas-powered pole saw. This current device is depicted in Figure 13 [15].



**Figure 13: Extendable Gas-Powered Saw [15]**

Currently, the device depicted in Figure 13 is used to trim palm trees that are a maximum of 17-feet tall from the ground. Patrick Howard conceived the aforementioned design concept because he has used the device in the field. This design concept would modify the device's shaft to reach a height of 40 feet. However, since a worker on the ground would not be able to see the top of the pole, a high-definition video camera would be mounted at the top of the device. This camera would connect via Bluetooth to a tablet mounted on the device to allow the operator to see the top of the palm tree and determine which fruit bunches to cut. This design concept is depicted in Figure 14.

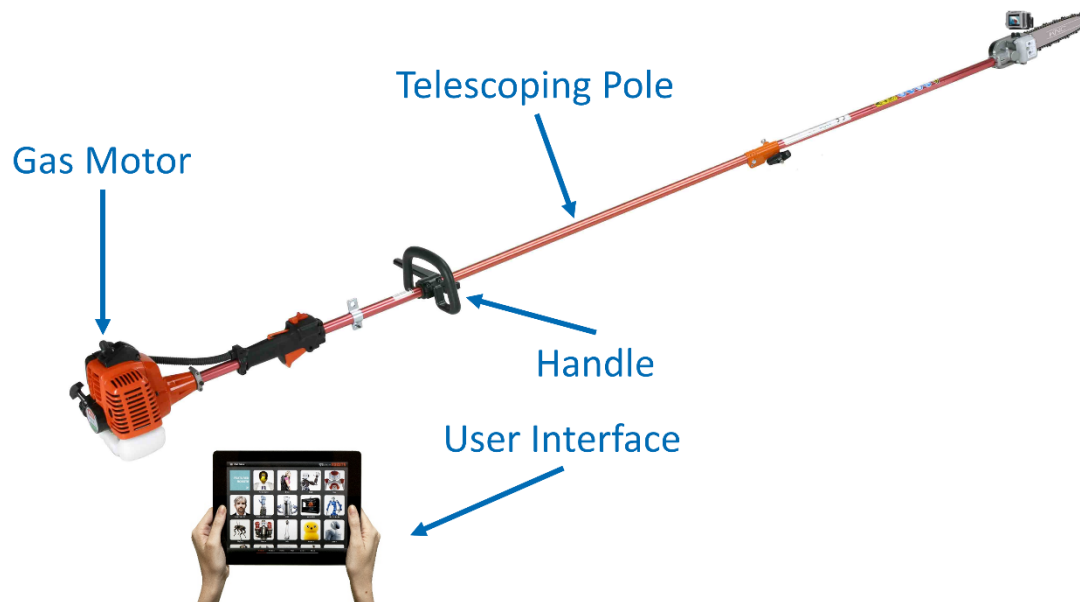
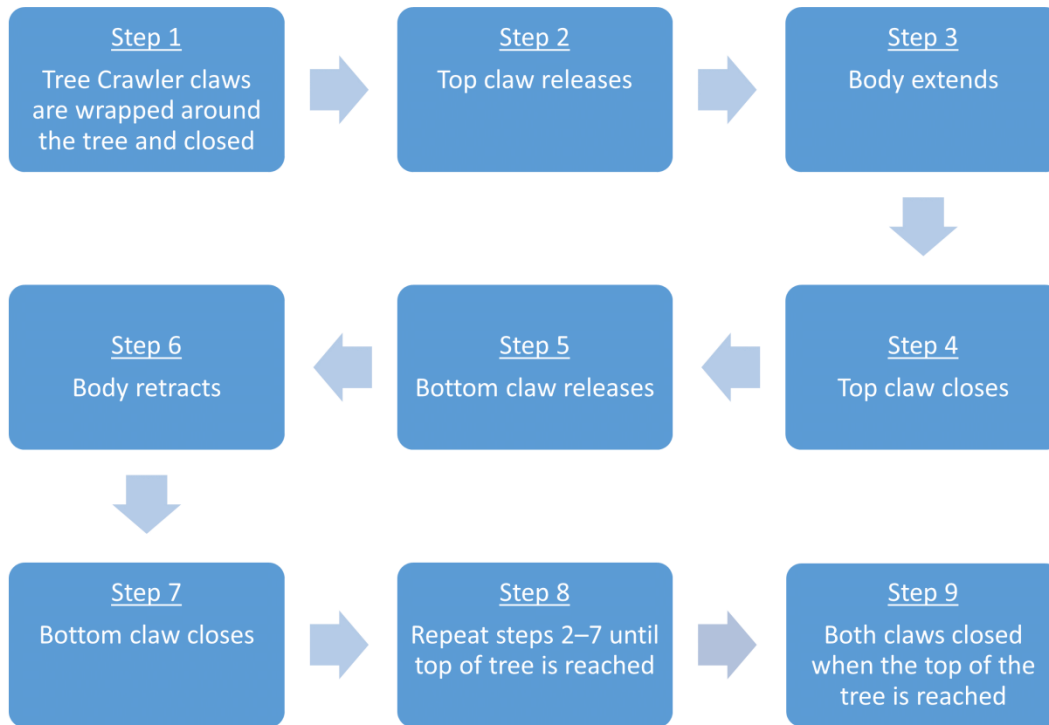

**Figure 14: Modified Pole Pruner Framework**

This design would meet all of the sponsor's requirements discussed in Section 3.1 and Section 3.5. However, the extended length of the pole saw would make it difficult for an operator to hold the device without it moving in undesired directions. Therefore, a telescoping tripod stand could be designed and built that would be able to be setup by one operator. This stand would help the user keep the device steady and act as a pivot point.

### 4.1.3 Tree Crawler

The tree crawler concept involves designing a mechanism that can ascend an oil palm tree, cut ripe fruit bunches, and then descend the tree safely. The mechanism consists of two claws, one at the top of the device and one at the bottom, which would wrap around the palm tree's trunk. A body will connect these two claws, which will be designed to retract and extend. The process by which this design would operate is depicted in Figure 15.



**Figure 15: Tree Crawler Operation Process**

As illustrated in Figure 15, both claws will need to close once the device has reached the top of the tree. To ensure the device stops at the proper location, the prototype will have a video camera that will be connected via Bluetooth to a display on the user's controller. This controller will allow the user to start and stop the device from ascending and descending the tree. Once the device is in the proper position at the top of the tree, the user will operate an extendable saw at

the top of the device to cut ripe fruit bunches, using the video camera's output. Once all desired fruit bunches have been harvested, the user will instruct the robot to descend the tree. The process depicted in Figure 15 operates in reverse when the device descends the tree. Finally, the user will transport the device to the next tree and repeat the process illustrated in Figure 15.

This design would meet all of the sponsor's requirements discussed in Section 3.1 and Section 3.5. However, this concept would require a large number of electromechanical components and an extensive amount of programming to operate efficiently. Adding more electromechanical components also increases the cost and weight of the device. Furthermore, as the number of components increases, the durability of the system decreases. The claw connectors would also have to withstand a large moment to support the weight of the machine and would also need to be resistant against the vibration that would occur when cutting fruit bunches.

The team selected a design that incorporates components from the aforementioned concepts. The design consists of four major components: the pole, the ring, the cutter, and the base. The cutter will stay on the ring and the ring will be attached around the tree at the base. The ring and cutter will then be lifted up using a series of poles that will attach to one another at the base. The base is intended to hold up the weight of the entire mechanism as the operator adds more poles to lift it up. It will also serve the purpose of adding stability to the overall structure.

## **4.2 The Pole**

The poling used to raise and lower the system is critical to preventing the design from collapsing. The pole will experience several different forces, such as bending stress from the weight of the ring and the cutting mechanism hanging from the end of it, as well as a vertical column stress from the weight of the track and cutter mechanism. Due to the sheer volume

associated with such a long pole, a lightweight material, in addition to a small cross-sectional area, is essential to maintain maneuverability. Two materials considered were aluminum 6061 and carbon fiber. Aluminum has a density of 0.0975 pound per cubic inch [16], while carbon fiber epoxy composite has a density of 0.0578 pound per cubic inch [17]. Clearly, carbon fiber is lighter than aluminum; however, aluminum costs \$0.66 per pound [18], whereas carbon fiber costs \$10 per pound [19]. Since the design is intended to be a proof of concept, aluminum 6061 was selected as the pole's material. In the final system, however, the manufacturer would most likely use an engineering plastic due to its much lighter weight and superior stiffness.

The connectors are designed to slip over the ends of the pipe; a male connector is located on one side and a female connector on the other. These connectors will consist of a series of drilled holes with screws to mount to the ends of the polling. As the user lifts the system up the tree, the next pole would insert into to the previous one and turn approximately 90 degrees to lock in place. These connectors would be made from aluminum to support the weight of the system when it is attached to the base.

Another design feature is the straps at the top and bottom of the system. These straps wrap around the tree and are used to secure the design to the tree. This feature provides added stability for the cutting mechanism as it traverses 360 degrees around the track, which will increase the stability of the ring. These bands would be made from thin aluminum sheets that remain flexible. The bands will be opened and closed by a heavy-duty thin rope that has a high tensile strength. The rope will run through the inside diameter of the poles and tighten when the user pulls the strap toward the ground. The rope will then be tied at the base of the pole to secure the system. The final part of the pole design is a connector that is rigidly attached to the ring at the top of the extended pole. The connector will need to be rigidly attached to prevent any major

deflection from the weight of the cutter mechanism. This connector will be machined from aluminum 6061 for strength and rigidity.

### **4.3 The Ring**

The ring is designed to wrap around an oil palm tree's trunk. The cutting mechanism will rotate around the trunk and will have a hinge and a lock that will allow the user to open it and wrap it around the base of the tree. The ring will then be lifted up the tree using the pole sections. Since weight and strength are critical for this design, the production model would ideally be made from a plastic material that has been engineered to have an acceptable strength-to-weight ratio. However, such a material would require an injection mold to be custom made, which would far exceed the given budget. Yet, such a mold would be cost effective for a final product, since the investment would eventually be recovered by the number of models sold. Therefore, as a proof of concept, this project will use aluminum instead of an engineering plastic, even though it will be heavier. The added weight from the aluminum, in addition to the weight of the cutter at a maximum distance of 5 feet from the pole, will cause the forces and moments to act upon the ring that must be considered. The shape of the ring will be a circular L-bracket with sides that measure 2 inches each and have an initial thickness of 0.25 inch. The ring is depicted in Figure 16 to scale.

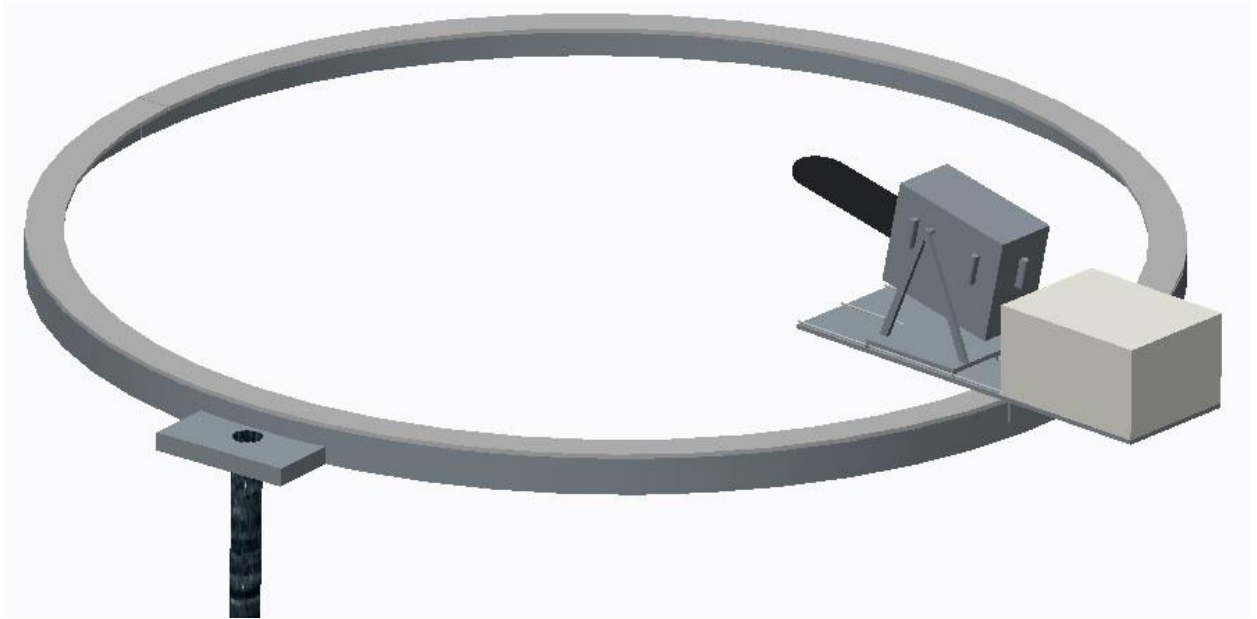

**Figure 16: Circular Cutter Track**

After performing finite element analysis (FEA) on the ring, the results showed that the largest stresses occurred near the pole, often reaching values close to 19 kips per square inch (ksi), the yield strength of aluminum 6061. Since this ring will be 40 feet in the air, as well as contain the most dangerous components of the design—the cutter—it is essential that every precaution be taken to prevent it from failing. The FEA showed that the stresses incurred by the 0.25-inch thick ring would not provide an acceptable factor of safety. Therefore, the thickness was then increased to 0.375 inch and another FEA was repeated and is displayed in Figure 17.

Stress von Mises (WCS)  
(ksi)  
Combination

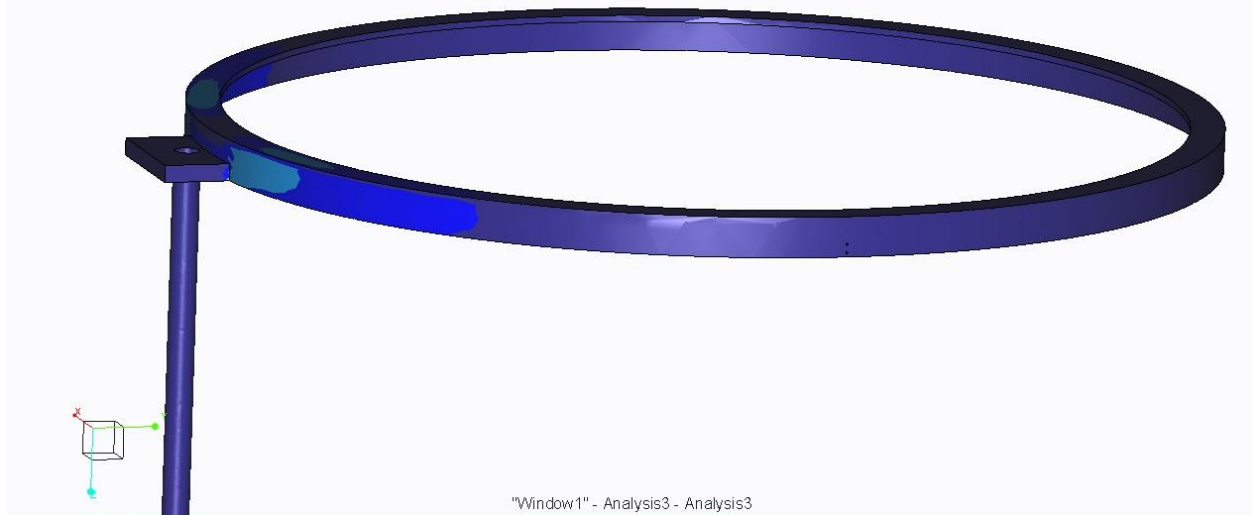
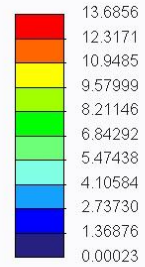

**Figure 17: Stress Analysis of the Ring**

Figure 17 shows that with the increase in ring thickness, the highest stresses experienced by the ring are around the pole mount and reach values of approximately 6.8 ksi. Since most of these stresses are concentrated around the pole mount, they can be further decreased by increasing the size of the pole mount to wrap around a larger portion of the ring. These stresses result in a factor of safety of approximately 2.8. Currently, the team considers the factor of safety of 2.8 to be acceptable.

Since only one side of the ring is secured to the pole and extends 5 feet away from it, its behavior will be similar to a cantilever beam. However, cantilever beams have greater risks of deflection than other structures. If the ring deflects too much, it could not only affect the functionality of the system by pushing the fruit bunches farther away, but repeated large deflections could cause fatigue to the material and result in the system's failure. The initial 0.25-



inch ring design exhibited large deflections, the highest of which reached 7 inches below the horizontal line. Considering the length of the chainsaw being used is only 8 inches, it is evident that this is an unacceptable amount of displacement. Thus, the 0.375-inch ring design was then analyzed for deflection by running a FEA and is depicted in Figure 18.

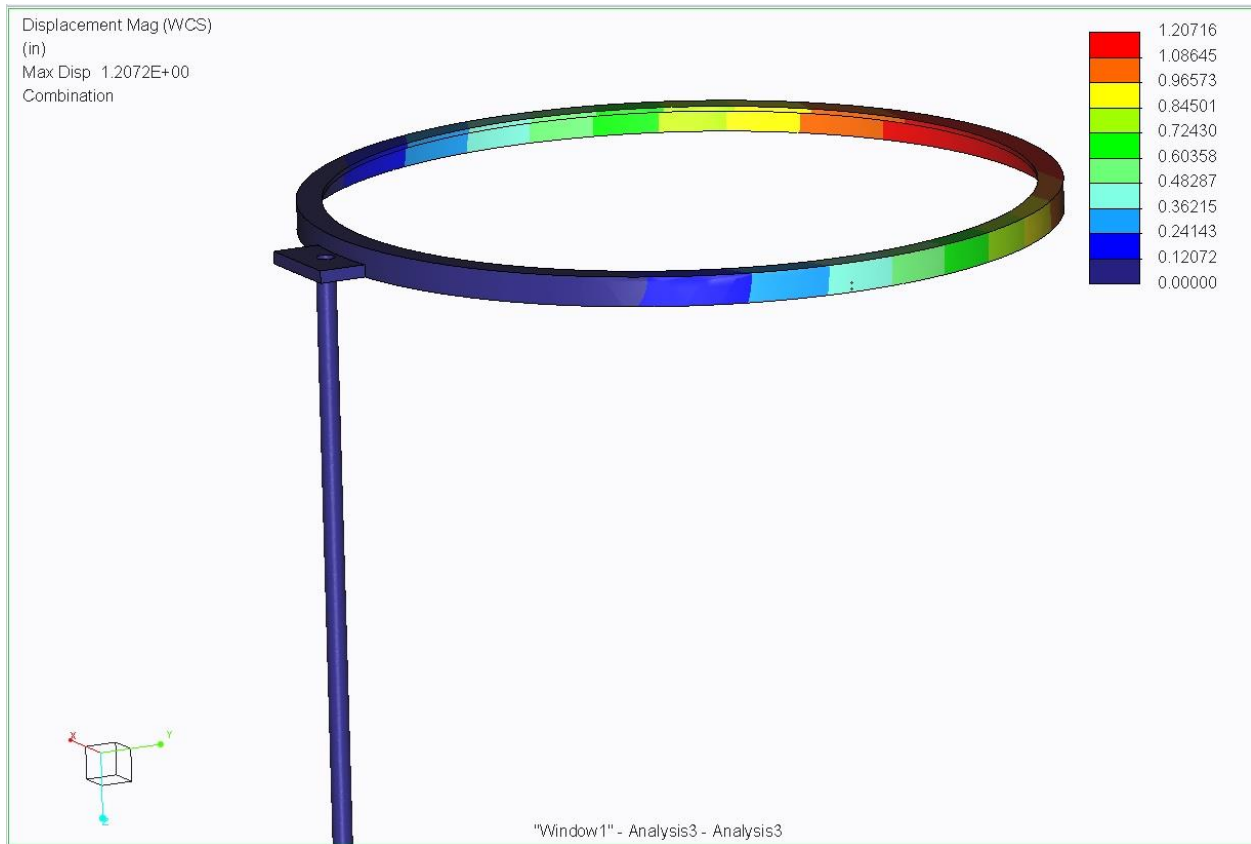

**Figure 18: Displacement Analysis of the Ring**

As Figure 18 shows, the 0.375-inch thick ring will not displace more than approximately 1.2 inches below the horizontal axis. Since the ring has a 5-foot diameter, this displacement represents less than 1 degree of deflection. For the current design, this displacement was deemed acceptable by the team. Each half of the ring will be made by cutting two long bands out of a 96-inch long sheet of aluminum. A roller will then be used to give the bands their circular shape. The top of the ring will be cut from the same sheet and then welded on top of the circular bands,

creating the L-shaped circle that is desired. The minimum size sheet that can be used to manufacture this ring is 38 inches high by 96 inches wide. Unfortunately, this increase in thickness comes with a disadvantage. Since this process results in a significant amount of scrap material, simply increasing the ring's thickness by 0.125 inch nearly doubled the cost from approximately \$600 to approximately \$1,100. If further analysis indicates that the 0.375-inch thick ring is also unacceptable, another increase in thickness would likely be too expensive to be considered.

#### **4.4 Cutting Mechanism**

The cutting mechanism depicted in Figure 19 will be set on an aluminum platform that will traverse around the circumference of the ring by utilizing a direct current (DC) motor. A second platform is mounted on top of a lead screw that controls its forward and backward translation. Two guide shafts will be adjacent to the lead screw to keep the secondary platform stable and balanced. The secondary platform will have two sets of trusses that support the weight of a box containing a DC motor that controls the saw and the stepper motor that controls its pitch. The height of the trusses and the size of the box are designed to give the saw 90 degrees of pitch. Though a larger angle of pitch is possible, it is not necessary or recommended, because it would mean that the saw is cutting fruit bunches directly over the platform. The saw blade being used is an 8-inch long chain saw that remains from the Class of 2015's design.

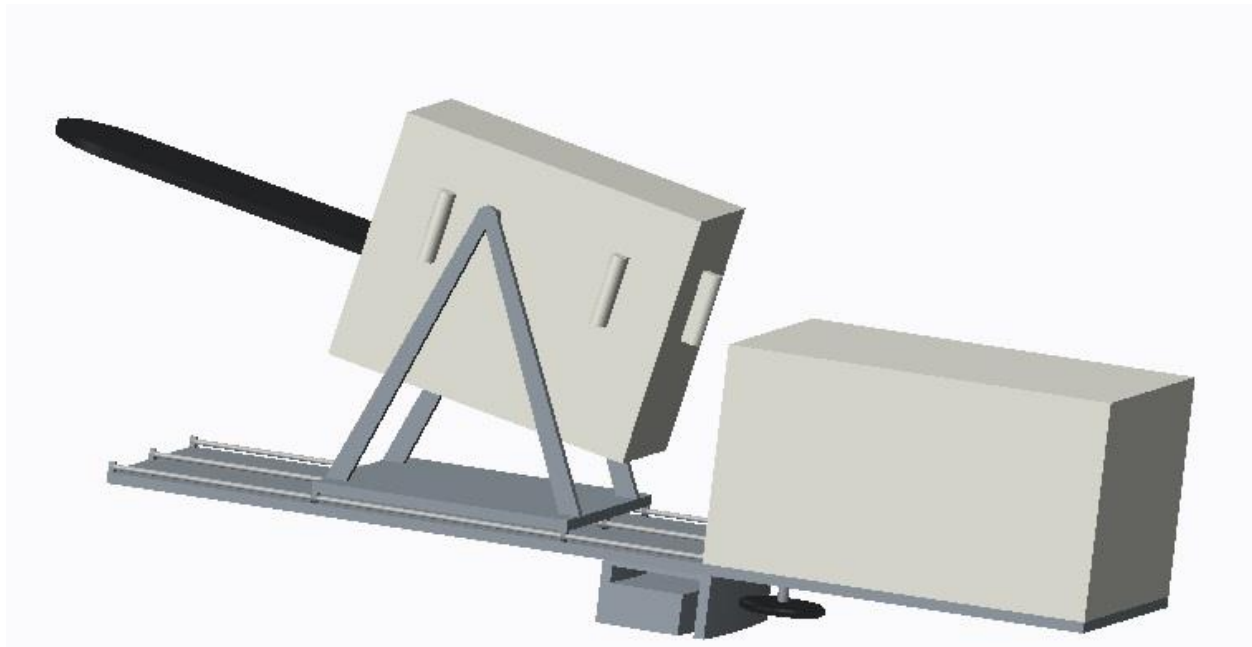

**Figure 19: Cutting Mechanism**

The cutting mechanism will be controlled using an Arduino UNO microcontroller similar to the one depicted in Figure 20 [20]. The Arduino UNO operates at 5 volts (V), has 14 digital input/output pins, 6 analog input pins, and 6 Pulse Width Modulation (PWM) input/output pins. The board operates at 16 megahertz, has 32 kilobytes (KB) of flash memory, and 2 KB static random-access memory. The board will be powered by D cell batteries connected by a USB adapter. This controller will control 3 DC motors and a stepper motor. These motors will be controlled using multiple L293D dual H-bridge motor drivers, shown in Figure 21 [21]. The pin layout of L293D is depicted in Figure 22 [22]. Pins 1 and 9 need 5 V to enable to use of the driver and pin 16 will also need 5 V for the combinational logic inside it. Pin 8 takes the voltage that will be released to the motors. Pin 4, 5, 12, and 13 are all connected to ground to allow current flow. Pins 2, 7, 10, and 15 take inputs from the Arduino board. Pins 3, 6, 11, and 14 are outputs connected to the motors. Pins 2, 7, 10, and 15 control pins 3, 6, 11, and 14, respectively.

When one of the input pins receives a signal from the board, the corresponding output pin receives the voltage from pin 8 of the driver.

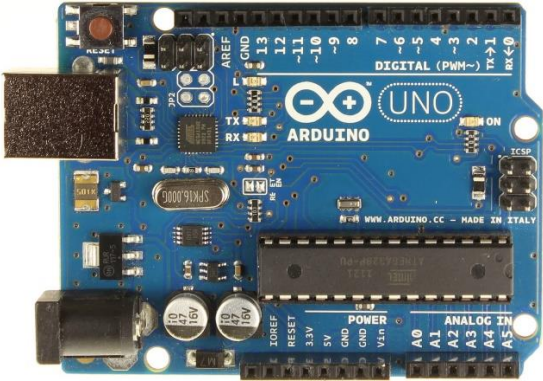

Figure 20: Arduino UNO Microcontroller [20]



Figure 21: L293D H-bridge Motor Driver [21]

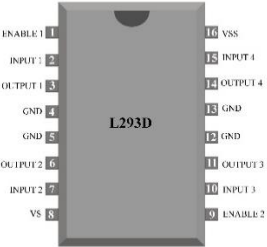
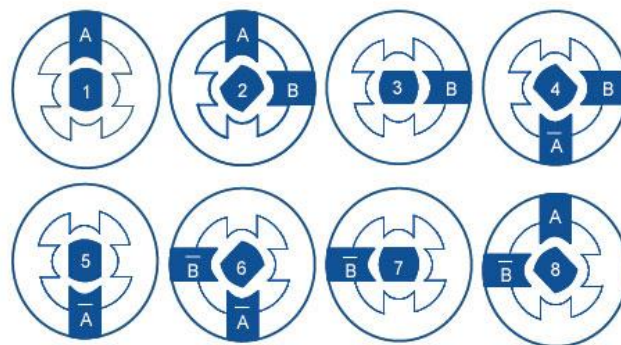

Figure 22: Pin layout of L293D [22]

For the DC motors to have the ability to run forward and backward, the positive end should be placed in one of the motor driver's output pins and the negative end in a different output pin. To go in one direction, one of the corresponding input pins must be set high, while the other remains low. The converse is true for the opposite direction. Two separate DC motors can be controlled with a single L293D H-bridge motor driver. The stepper motor selected has four phases and has four wires corresponding to each phase. Therefore, one complete motor driver must be used for the stepper motor. The stepper motor uses internal electromagnetic fields to move the magnet inside of the motor. When a current is applied to either of the two coils inside of the stepper motor, an electromagnetic field is created. The polarity of the electromagnetic field depends on the direction of the current. The two possible polarities of the electromagnetic field are each controlled by a wire. To control the direction of the stepper motor, the electromagnetic field of the coils must be turned on and off in sequence, as shown in Figure 23 [23].

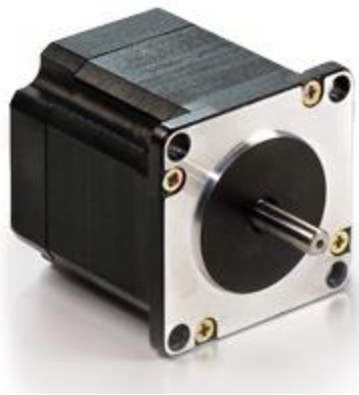

**Figure 23: Stepper Motor Forward Sequence [23]**

Two of the three DC motors that will be used is depicted in Figure 24 [24]. The stepper motor that will be used is depicted in Figure 25 [25].



**Figure 24: DC Motor [24]**



**Figure 25: Stepper Motor [25]**

Two DC motors and the stepper motor will be used for movement of the cutting mechanism. One DC motor will be used to traverse the track and the other will be used for the forward and backward translation of the saw. The two DC motors have a horsepower of 0.13, operate at 2,600 revolutions per minute (RPM), and run on 24 V. The RPM of the motor shown in Figure 24 will be geared downward to reach the required torque. A ratio of 1:5 was chosen to reduce the motor from 2,600 RPM to 520 RPM, but is subject to change due to the performance of the motors and the weight of the mechanism. The motors will be tested with a load similar to the load for the design. The duty cycle for the PWM signals will be determined through these

tests. The gears will be fabricated using additive manufacturing so that new ones are available to be made at any time. If the cutting mechanism traverses around the ring too quickly once the prototype is assembled, it can destabilize the ring and cause it to separate from the tree.

However, if the prototype's test results indicate that the speed of the motor needs to vary, it can be achieved using PWM signals. The third DC motor was acquired from the Black and Decker saw that remains from the Class of 2015's design. This motor operates at 18 V. The other specifications of the motor are unknown, because the manufacturer would not disclose the motor's specifications, but the motor is designed for the saw, guaranteeing smooth operation.

The stepper motor depicted in Figure 25 operates at 12 V, has an output torque of 600 ounce-inches, and requires 1 ampere per phase. All of the motors will be powered by 16 rechargeable D cell batteries with a rating of 10,000 milliamp hours. The resulting voltage of these batteries will be 24 V and will require the creation of a voltage regulator for the stepper motor and the saw motor. Using these batteries, the cutting mechanism will be able to run continuously for a minimum of 3.5 hours, assuming that the mechanism will be used in a 10-hour workday. Assembly, disassembly, and operating time are each estimated to require 5 minutes each. The cutting mechanism will have sufficient power to last the entire period. An Arduino template file for the usage of all these motors has been created.

The full schematic cutting mechanism's electronics is depicted in Figure 26. A total of 11 input/output pins are used in the Arduino UNO board, which leaves three extra pins in case more are needed. The cutting mechanism will be controlled wirelessly by the user with the use of radio frequencies. The receiver and transmitter selected is shown in Figure 27 [26]. These components operate at 433 hertz and are made for the Arduino microcontrollers. An Arduino library and template files for the operation of these devices have been obtained from online sources [27].

The receiver will be placed in the cutting mechanism and the transmitter will be inside the wireless controller. The transmitter will be able to send a signal to the cutting mechanism when powered with 12 V and an antenna of at least 6 inches. The controller will also be operated using an Arduino UNO microcontroller and will be powered using 8 AA cell batteries. An Arduino Joystick Shield will be used for user input and is depicted in Figure 28 [28]. This shield is made specifically for the Arduino UNO. The left and right movement of the joystick will maneuver the cutting mechanism around the ring. The up and down movement of the joystick will move the saw in and out. Button D will turn the saw on and button A will turn it off. Button B will pitch the saw upward while button C will bring it downward. The schematic for the Joystick Shield connected to the Arduino UNO is shown in Figure 29 [29]. The transmitter will be connected to any of the unused pins. The casing for both the controller's electronics and the cutting mechanism will be created using additive manufacturing. The circuitry for the cutting mechanism will be soldered to decrease holding space. A camera will be screwed onto the casing of the cutting mechanism's electronics. The monitor of the camera will be screwed onto the casing of the controller. The camera and the monitor will both operate at 5 V. The camera and monitor are depicted in Figure 30 [30].



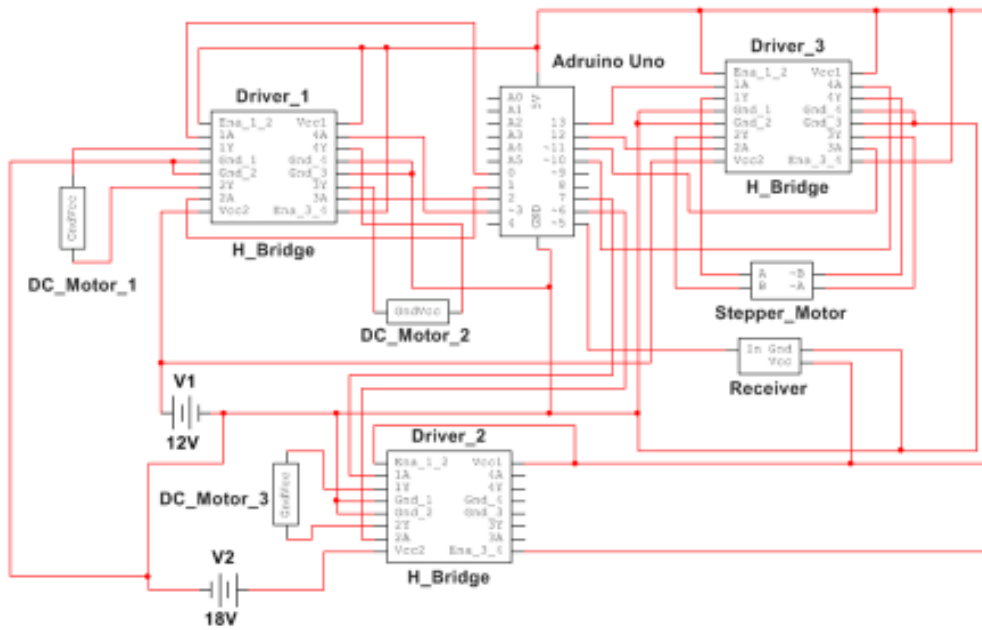

Figure 26: Cutting Mechanism Schematic

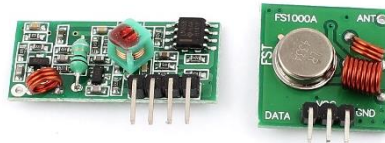

Figure 27: Receiver (left) and Transmitter (right) [26]



Figure 28: Arduino Joystick Shield [28]

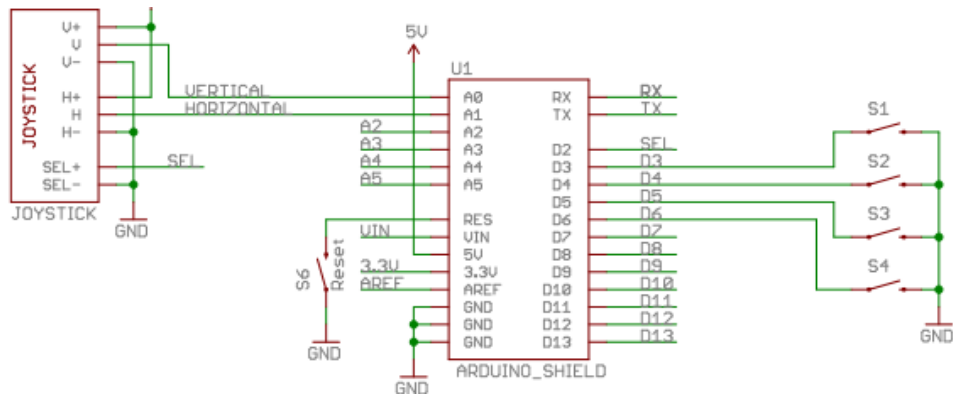

Figure 29: Joystick Shield Schematic [29]



Figure 30: Camera and Monitor [30]

## 4.5 The Base

The base of the system will consist of four legs joined together by links at a central point and is depicted in Figure 31. When the user is finished cutting the fruit bunches and disassembling the pole, the links will move upward and the stand will retract similar to a tripod.



**Figure 31: Rendering of the Base**

In addition to adding stability, the stand will also bear the weight of the pole, cutter, and ring, while the worker inserts additional pole sections from the bottom. Since this is a proof-of-concept design and expensive materials are not able to be used for the pole, the joint at the top of the base that holds the legs and pole in place must be able to support the weight of a 40-foot tall aluminum pole. Assuming that the heaviest pole that would be used would have a diameter of 2 inches and a thickness of 0.25 inch, a total pole weight of roughly 50 pounds was set based on the density of aluminum. Moreover, the combined weight of the 15-pound cutter and the 25-pound aluminum ring resulted in the total applied weight on the joint being 90 pounds. The FEA of the aluminum joint under this stress is depicted in Figure 32.

Stress von Mises (WCS)  
(ksi)  
Loadset:LoadSet1 : PRT0002

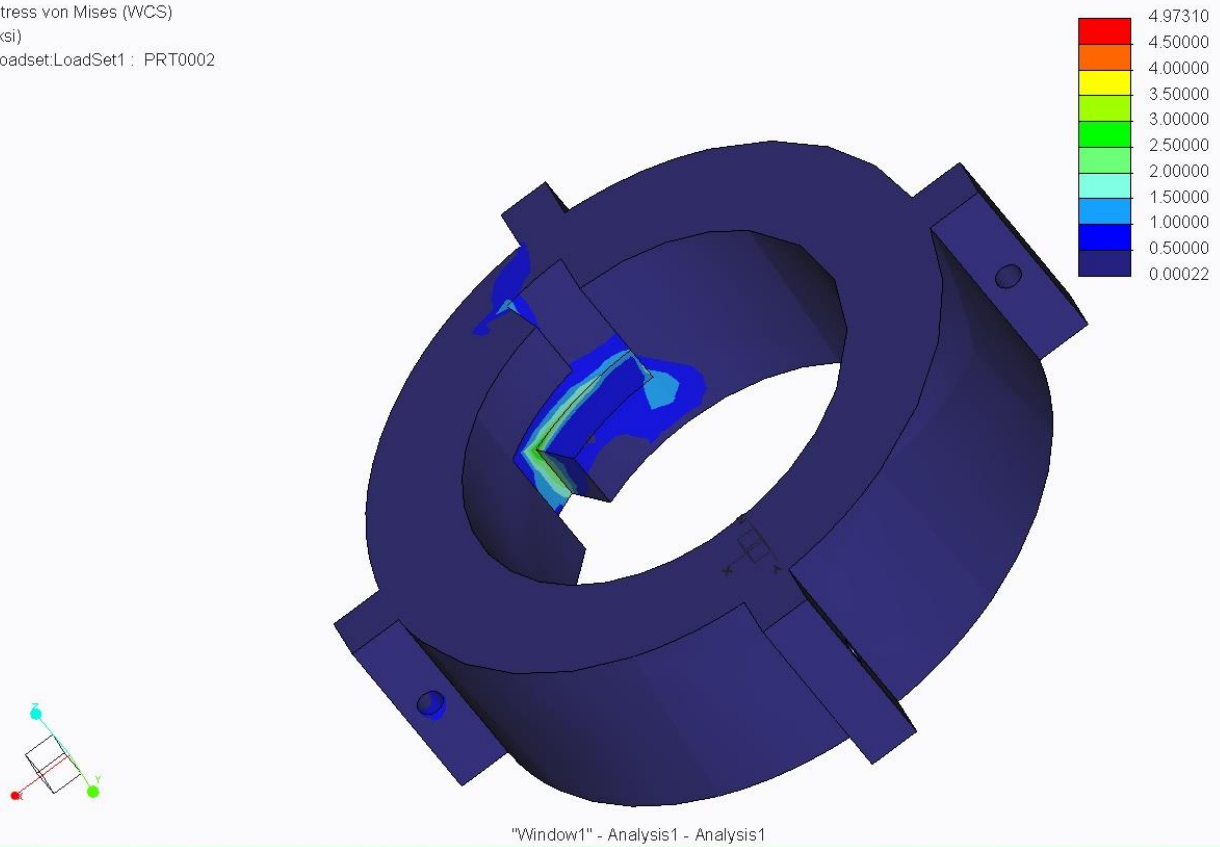

**Figure 32: Stress Analysis of the Aluminum Joint, Top View**

As shown in Figure 32, the majority of the weight will be concentrated on the locking mechanism. This joint will not experience more than 3 ksi of stress on this side, which is far less than the yield stress of aluminum. The greatest stress is experienced by the pin hole on the other side as seen in Figure 33.

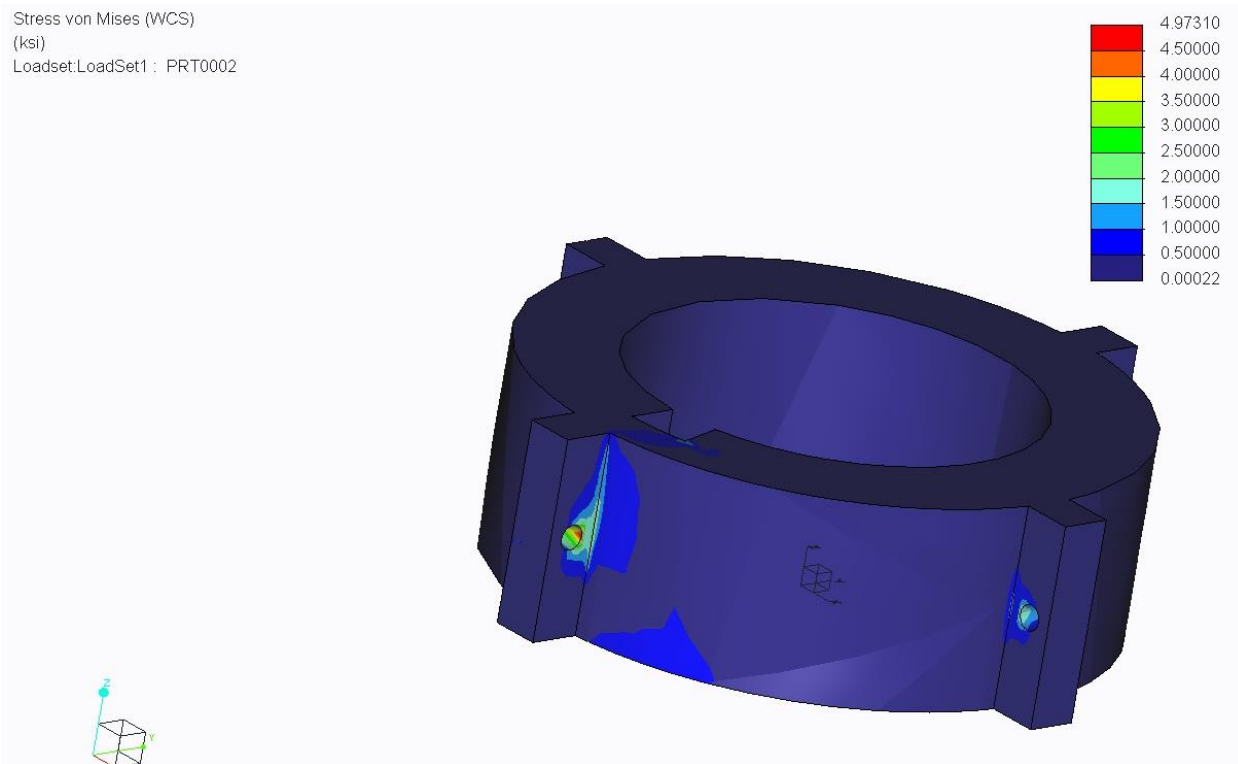

**Figure 33: Stress Analysis of the Aluminum Joint, Side View**

The pinhole closest to the locking slot experiences far greater stress than the other three, indicating that the weight is not evenly distributed among the pin holes. However, the highest stress shown is just under 5 ksi, which results in a factor of safety of about 3.8. The team decided this factor of safety is sufficient and does not necessitate redesign. However, if a higher factor of safety is desired, the locking slot could either be moved to distribute the weight better between an adjacent pinhole, more slots could be added to the interior of the joint, or the material could be changed to steel. Since the pin joints display non-uniform distribution of stress, it was necessary to also analyze the pins. In Figure 34, the total 90-pound weight was applied to the 0.25-inch section that is covered by the pinhole and was constrained at the ends of this section, because it is where the highest level of shear stress is expected to be experienced.

Stress von Mises (WCS)  
(ksi)  
Loadset: LoadSet1: STAND\_PIN2

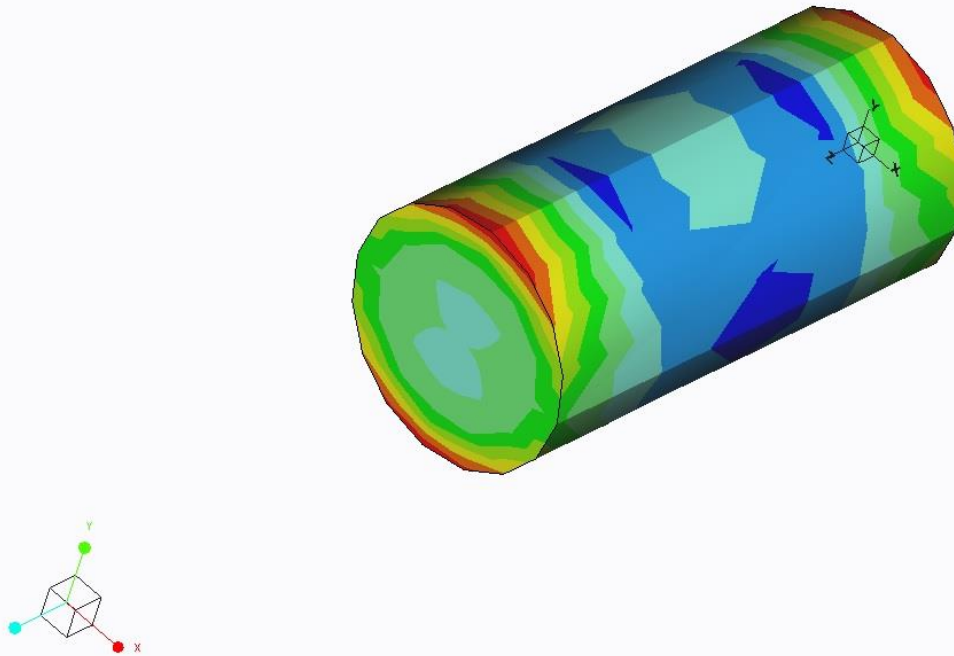
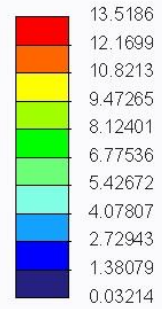

"Window1" - Analysis1 - Analysis1

**Figure 34: Stress Analysis of the Pin for Base Leg**

The pin experiences a higher stress than the pinhole, because it is not as reinforced. The highest stress exhibited by the 0.125-inch diameter pin was about 13.5 ksi, which was far enough from the 19-ksi yield stress value of aluminum for it to produce an acceptable factor of safety. However, steel pins are more common and less expensive than aluminum pins and the yield strength of A36 steel is approximately 36 ksi [31]. Therefore, if a steel pin is used, it will give a minimum factor of safety of about 2.7, which was deemed acceptable by the team.

## 5. Analysis of Selected Design

### 5.1 Modifications

#### 5.1.1 Cutter

During this phase, this cutter design was reevaluated for improvement. By rearranging the electrical components within the box, its size was able to be decreased from 9 inches by 7.5 inches by 5 inches (length by width by height) to 4 inches by 4 inches by 5 inches. Additionally, rather than having a wheel use friction to traverse around the circumference of the ring, a rack and pinion system will be used to reduce the likelihood of slippage. The platform upon which the cutter is mounted was also modified. Rather than a square-shaped platform with a triangular set of trusses, the new design uses a narrow rectangular platform and two thicker trusses for support. The thickness of the trusses will be  $\frac{3}{8}$  inch, allowing for greater vibration resistance and ease of manufacturing, since it will be made from the same stock material as the ring. Figure 35 depicts the new cutter design.

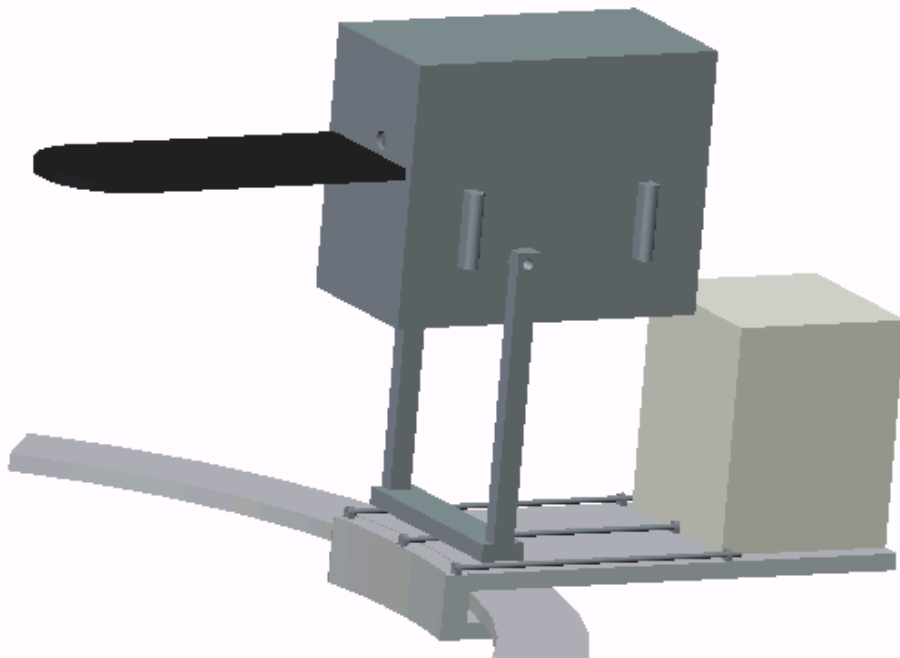

Figure 35: Modified Cutting Mechanism

### 5.1.2 Ring

The initial design for the ring consisted of a circular ring that would enclose the entire circumference of the tree's trunk, allowing for 360-degree access to the palm fruit. Due to budgetary constraints, aluminum was selected to fabricate the ring. In the previous phase, the ring was designed with an L-shaped cross section and a thickness of 3/8 inch. However, after a more complete analysis was conducted in this phase, it was found that with a thickness of 3/8 inch the L-shape would not be necessary to prevent excess deflection.

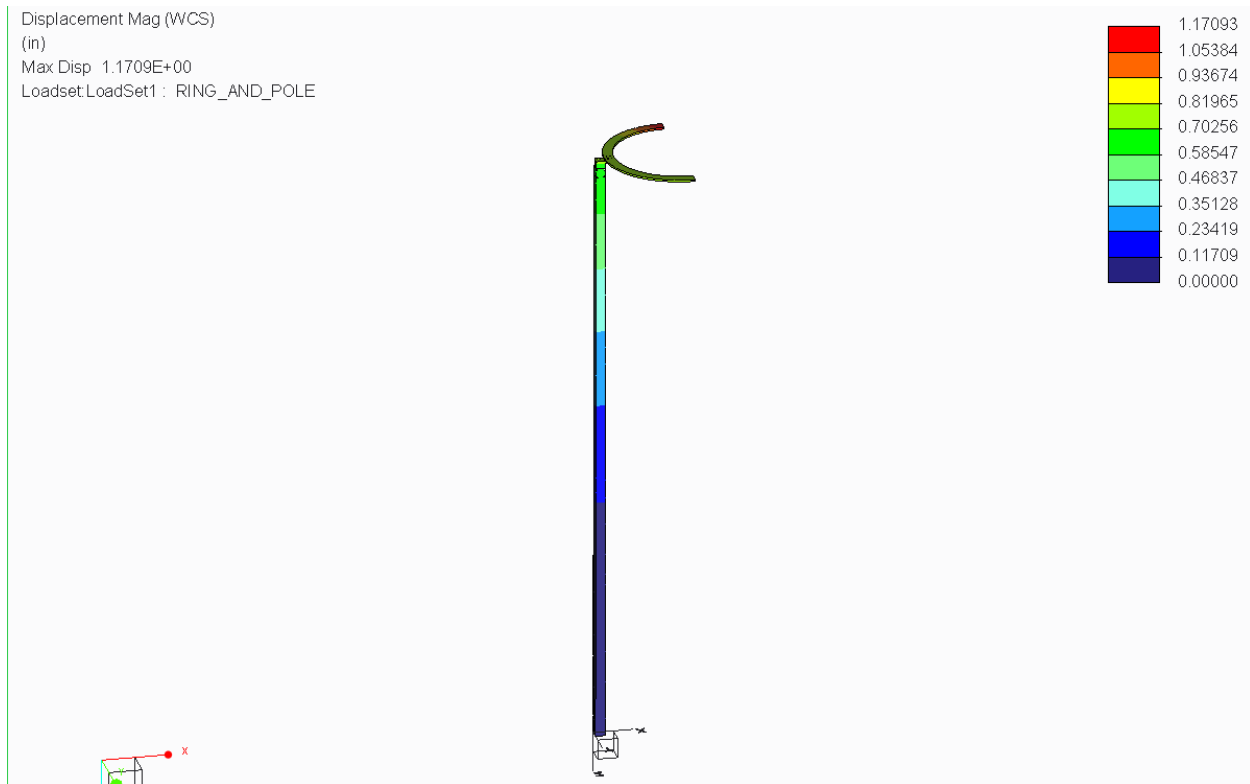
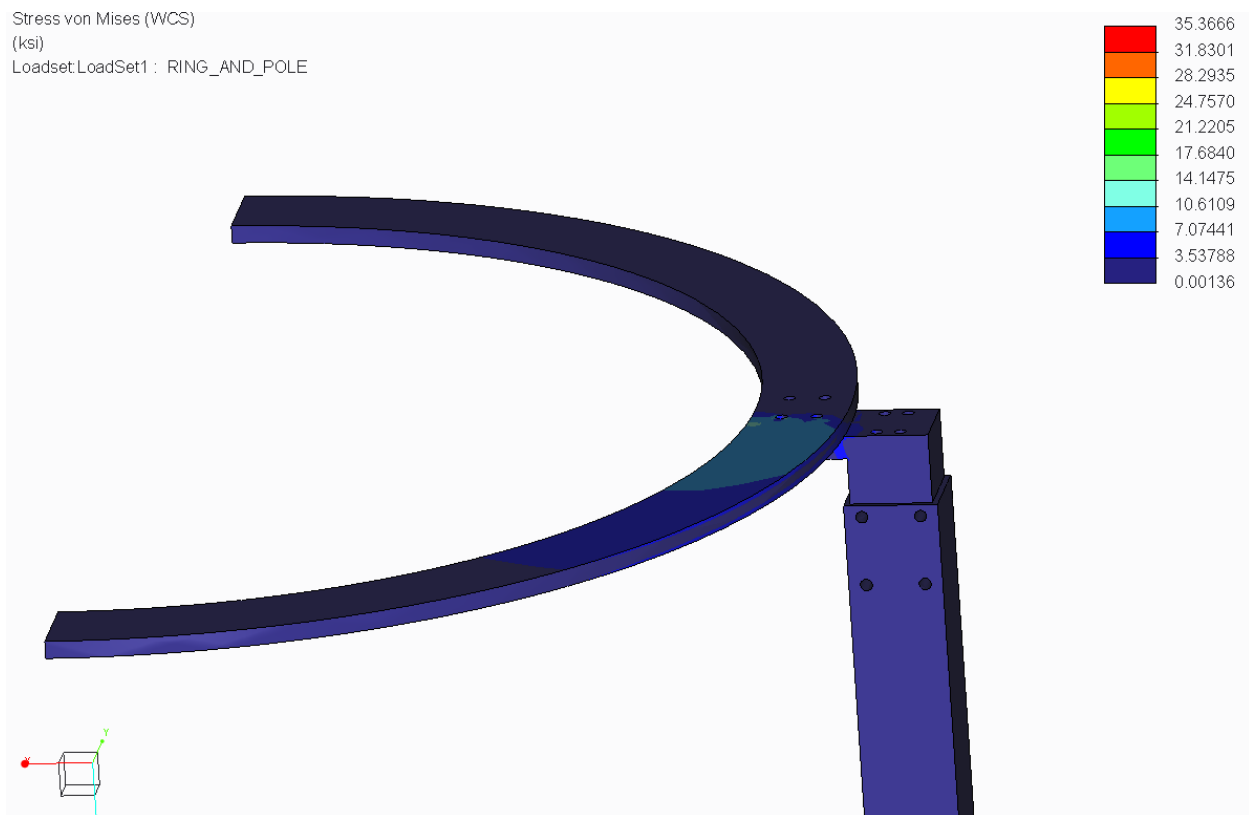

Figure 36: Deflection Analysis of Modified Ring

As shown in Figure 36, the new ring will actually experience slightly less deflection than the previous one, due to its lighter weight. The L-shape as a track was further proved obsolete with the use of the rack and pinion system. Additionally, to further decrease the weight of the ring, the fully circular ring was replaced with a semicircular ring and with the length of the



cutting mechanism concentrated on the outer edge of the ring, the diameter was also able to be decreased from 60 inches to 30 inches. The ring will also be attached to the pole from its bottom, rather than its side, to further relieve the stresses acting upon it. After the ring design was completed, a FEA was conducted on it and is depicted in Figure 37.



**Figure 37: Stress Analysis of Modified Ring**

Figure 37 shows that the highest stresses experienced by the actual ring will be no more than about 14 ksi, and with aluminum having a yield strength of 40 ksi, this new design will give a factor of safety of about 2.9. The higher stresses of up to 35 ksi depicted by the FEA will be felt by the block that connects the ring to the pole. According to the FEA, this will only be felt in a region thousandths of an inch wide and therefore will likely not cause excessive yielding throughout the rest of the block.

### 5.1.3 Pole

In the previous phase, a design for a poling system was selected but was not analyzed in time for the previous report, due to unknown errors in the FEA. The design consisted of a series of aluminum poles that were connected to one another with clamps and then lifted upward with the ring by the operator. However, this design was intended to be light enough to be carried by hand around a large plantation; after further analysis, it was determined that in order to withstand the column stresses associated with the weight of the ring and cutter, the pole would have to be over 4 inches in diameter. A pole of this diameter would mean that the total system weight would be approximately 100 pounds, which would be far too heavy to be carried by hand. The design was then modified using the Class of 2015's telescoping poles. The telescoping poles are elevated using a system of pulleys shown in Figure 38.

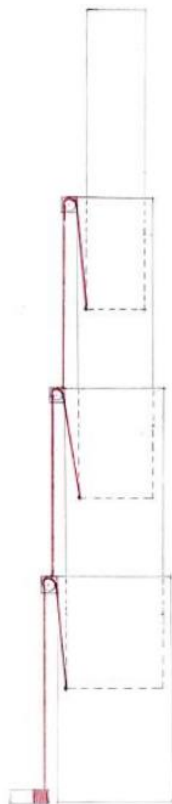

Figure 38: Previous Year's Pulley Mechanism

As shown in Figure 38, the pulley mechanism consists of three separate steel wires that are each grounded to a different pole. As the winch pulls the first wire and lifts the second pole, it will pull on the wire connected to the first stationary pole, which will cause the next pole to be lifted. The entire system will consist of four poles that are each 10 feet long, which sums to the required 40 feet. Each pole has a square cross section for easier machinability and component attachment; each pole's outside widths, from the base pole to the top pole, are 5 inches, 4 inches, 3 inches, and 2 inches. The square cross section also allows for easier adaptation to the new ring and cutter mechanism, since it can be more easily attached.

The main benefit of using the poles from the Class of 2015's design is that thorough analysis and testing has already been conducted on them. The Class of 2015 designed the poles to withstand high wind speeds and carry a weight of 40 pounds. Their FEA is shown in Figure 39 [9].

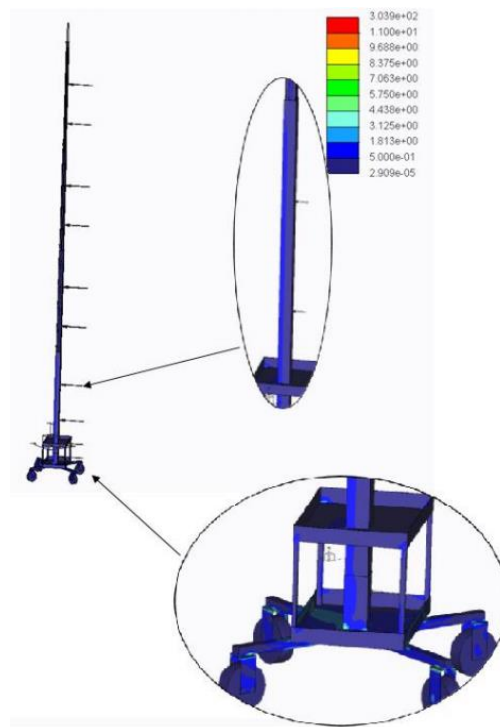
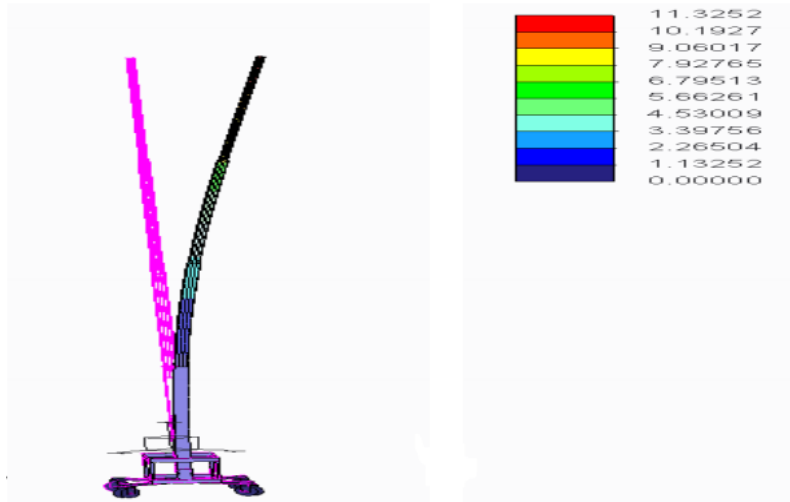

Figure 39: FEA of the Class of 2015's Design [9]

The results of the FEA indicate that the stress within the pole itself will not exceed 6 MPa (0.9 ksi). The higher stresses are felt within the cart that will be redesigned. Additionally, the previous year conducted a deflection analysis of the cart, shown in Figure 40.



**Figure 40: Deflection Analysis of the Class of 2015's Design**

The analysis in Figure 40 indicated that with their applied loads, the Class of 2015's design would not exhibit more than 11 mm (0.4 inch) in deflection, which is acceptable for a mechanism of this size. Since, the Class of 2015's poling system demonstrated that it was capable of lifting their 40-pound cutting mechanism without experiencing excess stress or deflection. Therefore, it is reasonable to conclude that it would be possible to attach the current team's cutting mechanism, which is expected to weigh less than 25 pounds, to the top of the polling system with no added risk of failure. However, because the weight of the poles is expected to exceed over 100 pounds, and the weight of the winch and battery will add another 60 pounds, the possibility of carrying the system by hand must be abandoned and an acceptable mobility platform must be designed.

#### 5.1.4 Cart

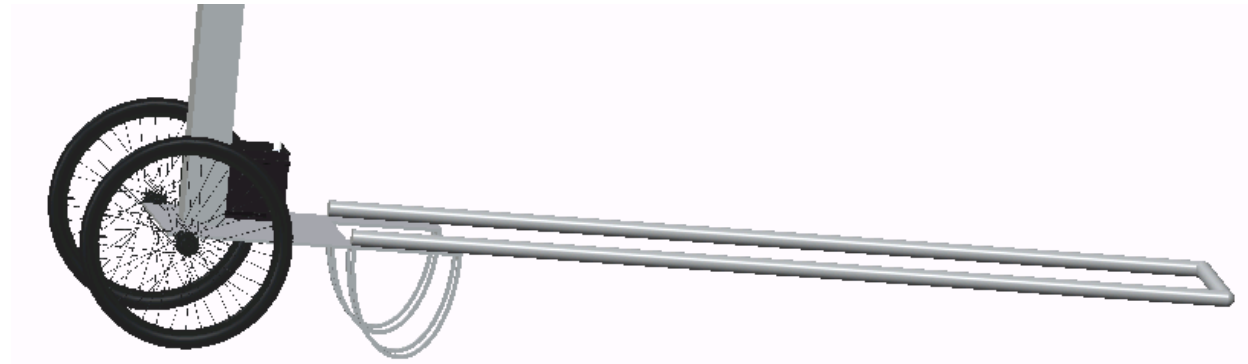

**Figure 41: Cart**

The mobility platform design that was selected is depicted in Figure 41. It is similar to the design of many modern rickshaws; by using long extended handles the operator is able to apply a large moment around the axis of the wheels, allowing them to lift and pull large amounts of weight. Unlike the Class of 2015's design, which utilized a four-wheeled cart, the mobility platform will use only two wheels, which will make it easier to maneuver on rough terrain. The cart's chassis will be modified from an existing 2-wheel wheelbarrow, to ensure that it is capable of withstanding the weight of the entire poling system. A FEA of the cart was conducted and is depicted in Figure 42.

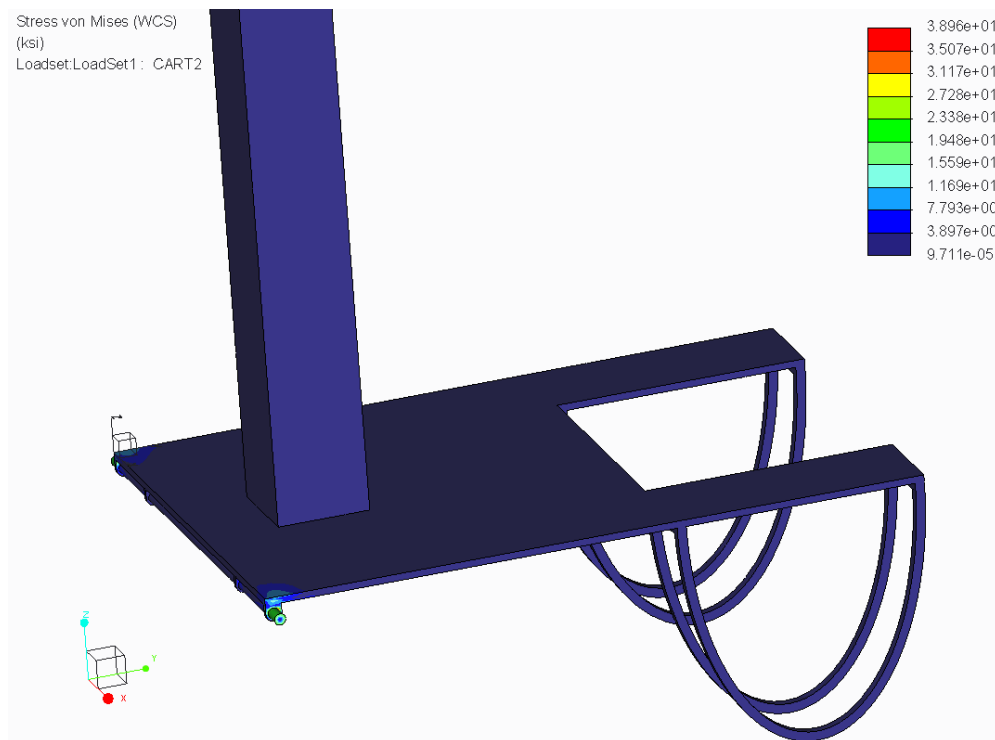

**Figure 42: Stress Analysis of the Cart**

As shown by the FEA in Figure 42, the platform itself will not experience greater than 16 ksi of stress. Most of the higher stress values will be directed toward the wheelbarrow chassis, which is rated for 400 pounds, far less than the weight of the polling system.

### **5.1.5 Electrical Components**

A winch motor and a battery have been added to the base of the cart to assist with raising the telescoping pole. The winch motor selected is the Trakker 1-horsepower 2,000-pound Universal Winch and is shown in Figure 43. Since the weight of the telescoping pole and cutting mechanism is a small fraction compared to the capability of the winch, the motor will only need a fraction of its total power. Though the exact value of the amperes (A) drawn from this motor cannot be determined until it is tested, the team estimated that it will be between 20A–25A as a worst-case scenario; this estimation is half the value of the potential amperage the motor can draw. The battery that will power this winch is the 12-volt Super State Marine – Deep Cycle

Battery and is shown in Figure 44. This battery is rated to last 225 minutes with a continuous draw of 23 amperes. The Palm Harvester group from Class of 2015 claimed that their telescoping pole using the same components took a total of 38 seconds to ascend and descend. Using this information and the energy capacity of the battery, this set up will allow the mechanism to ascend and descend a total of 355 times throughout one battery life. If the device were used for 12 hours, it would have to ascend and descend a tree 30 times every hour to drain the battery completely.

The addition of these two components will require an Arduino microcontroller at the base along with a motor driver and another receiver. The motor driver for this motor will need to be capable of supplying more amperage than the other motor drivers; therefore the team has selected the motor driver, shown in Figure 45, that supports up to 30 amperes continuously. Having two different receivers will not cause an issue as long as the software is set up correctly. The second receiver has been ordered and is currently being delivered. Once the shipment is received, it will be connected to an Arduino microcontroller separate from the other transmitter and receiver and the functionality of the whole system will be tested.



**Figure 43: Winch Motor**



Figure 44: 12V Super State Marine Deep Cycle Battery



Figure 45: Motor Driver for Winch Motor

## 5.2 Testing

The Arduino wireless transmitter and receiver have been purchased and the order has arrived. The wireless components have been tested and the results suggest that they work properly. To test the functionality of these components, Derek and Alberto connected the receiver to an Arduino microcontroller and the transmitter to a separate microcontroller. The sample code for the components given from the manufacturer was utilized and altered for our test. The microcontroller connected to the transmitter was programmed to receive user input from a joystick (connected to the board) and then would transmit data depending on the user input. The microcontroller connected to the receiver was programmed to receive input from the transmitter and would use that input to decide which LEDs (connected to the board) to toggle on



or off. Using four LEDs, this simulated the manipulation of the motor driver to control two DC motors and the motor driver to control the stepper motor. With the transmitter operating at 9V volts and an antennae length of 4 inches, the receiver was able to pick up a signal wirelessly from approximately 160 feet. This would be enough distance to reach the cutting mechanism when it is erected, however, our design will work from 260–330 feet when the transmitter is operated at 12 volts, with an antennae length of 6 inches. The circuits used for this test and the code used are depicted in Figure 46, Figure 47, Figure 48, and Figure 49, .

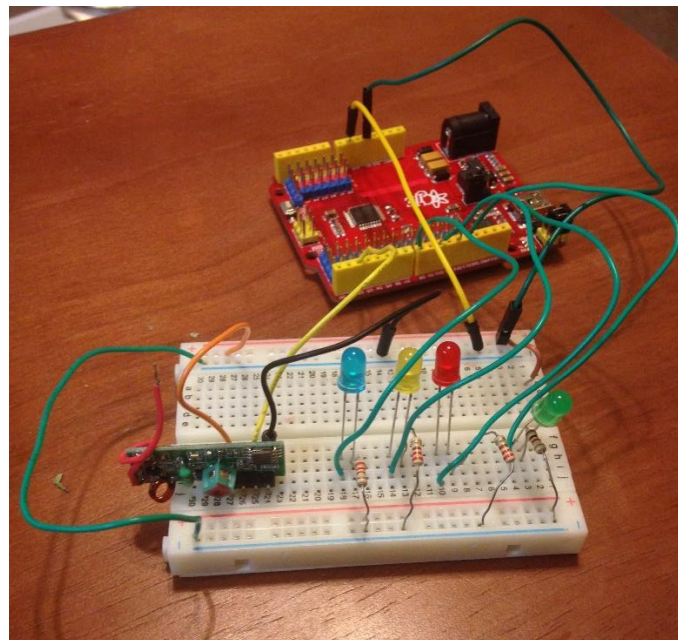

**Figure 46: Receiver Testing Circuit**

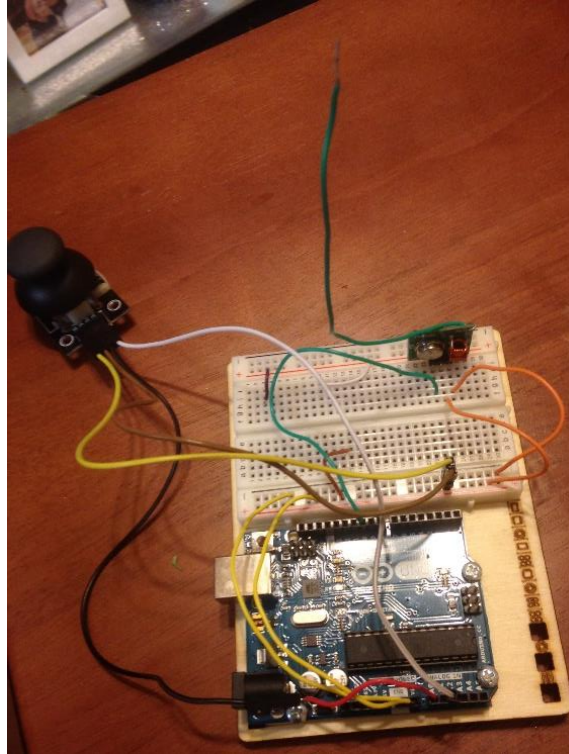

Figure 47: Transmitter Testing Circuit

```

void loop() {

    int sensorValx = analogRead(A0);
    int sensorValy = analogRead(A2);

    if(sensorValx < hundred)
    {
        mySwitch.send("0000000000000000000000010");
    }
    else if(sensorValy < hundred)
    {
        mySwitch.send("0000000000000000000000001");
    }
    else if(sensorValx > nine_hundred)
    {
        mySwitch.send("000000000000000000000000100");
    }
    else if(sensorValy > nine_hundred)
    {
        mySwitch.send("0000000000000000000000000101");
    }
    else
    {
        mySwitch.send("000000000000000000000000001");
    }
}

#include <RCSwitch.h>

RCSwitch mySwitch = RCSwitch();
const int hundred = 100;
const int nine_hundred = 900;
void setup() {

    Serial.begin(115200);

    // Transmitter is connected to Arduino Pin #10
    mySwitch.enableTransmit(10);
}

```

Figure 48: Transmitter Testing Code

```

#include <RCSwitch.h>

RCSwitch mySwitch = RCSwitch();

const int one = 1;
const int two = 2;
const int three = 3;
const int four = 4;
const int five = 5;
const int blue = 8;
const int yellow = 10;
const int red = 12;
const int green = 13;
int state = one;
void setup() {
  Serial.begin(115200);
  mySwitch.enableReceive(0); // Receiver on interrupt 0 => that is pin #2
  pinMode(blue, OUTPUT);
  pinMode(yellow, OUTPUT);
  pinMode(red, OUTPUT);
  pinMode(green, OUTPUT);
}

void loop() {
  if (mySwitch.available()) {
    int value = mySwitch.getReceivedValue();

    if(value == two) // turn on only blue LED
    { // when joystick is Left
      digitalWrite(blue, HIGH);
      digitalWrite(yellow, LOW);
      digitalWrite(red, LOW);
      digitalWrite(green, LOW);
    }
    else if(value == three) // turn on only yellow LED
    { // when joystick is Down
      digitalWrite(blue, LOW);
      digitalWrite(yellow, HIGH);
      digitalWrite(red, LOW);
      digitalWrite(green, LOW);
    }

    else if(value == four) // turn on only green LED
    { //when joystick is Right
      digitalWrite(blue, LOW);
      digitalWrite(yellow, LOW);
      digitalWrite(red, LOW);
      digitalWrite(green, HIGH);
    }
    else if(value == five) // turn on only red LED
    { // when joystick is Up
      digitalWrite(blue, LOW);
      digitalWrite(yellow, LOW);
      digitalWrite(red, HIGH);
      digitalWrite(green, LOW);
    }
    else // turn off all leds
    { //when joystick is in middle position
      digitalWrite(blue, LOW);
      digitalWrite(yellow, LOW);
      digitalWrite(red, LOW);
      digitalWrite(green, LOW);
    }
    mySwitch.resetAvailable();
  }
}

```

**Figure 49: Receiver Testing Code**

The joystick shield will act as the controller for the system; it has been ordered and is currently being shipped. Testing the controller will be similar to the testing of the wireless components. The previous code for the transmitter utilized a separate joystick for user input. The new code is modified to use the joystick on the joystick shield for user input along with the buttons on the shield. The code for this has been made and is shown in Figure 50 and Figure 51. All different combinations will send a different signal that will toggle the LEDs in a unique pattern. Once the joystick shield works correctly, it will be used to as user input for the remaining tests. The controller will be deemed to have successfully pass its tests once every source of user input on it works properly.

```

#include <RCSwitch.h>

RCSwitch mySwitch = RCSwitch();
const int hundred = 100;
const int nine_hundred = 900;
const int button_A = 2;
const int button_B = 3;
const int button_C = 4;
const int button_D = 5;
const int button_E = 6;
const int button_F = 7;

void setup() {
  Serial.begin(115200);
  //Transmitter is connected to Pin 10
  mySwitch.enableTransmit(10);
  pinMode(button_A, INPUT);
  pinMode(button_B, INPUT);
  pinMode(button_C, INPUT);
  pinMode(button_D, INPUT);
  pinMode(button_E, INPUT);
  pinMode(button_F, INPUT);
}

void loop() {
  int sensorValx = analogRead(A0);
  int sensorValy = analogRead(A1);

  if(sensorValx < hundred)
    mySwitch.send("0000000000000000000000010");
  else if(sensorValy < hundred)
    mySwitch.send("0000000000000000000000011");
  else if(sensorValx > nine_hundred)
    mySwitch.send("00000000000000000000000100");
  else if(sensorValy > nine_hundred)
    mySwitch.send("00000000000000000000000101");
  else if(button_A == HIGH)
    mySwitch.send("00000000000000000000000110");
  else if(button_B == HIGH)
    mySwitch.send("00000000000000000000000111");
  else if(button_C == HIGH)
    mySwitch.send("000000000000000000000001000");
  else if(button_D == HIGH)
    mySwitch.send("000000000000000000000001001");
  else if(button_E == HIGH)
    mySwitch.send("000000000000000000000001010");
  else if(button_F == HIGH)
    mySwitch.send("000000000000000000000001011");
  else
    mySwitch.send("0000000000000000000000001");
}

```

Figure 50: Controller Testing Code for Transmitter

```

#include <RCSwitch.h>
RCSwitch mySwitch = RCSwitch();
const int neutral = 1;
const int js_left = 2;
const int js_down = 3;
const int js_right = 4;
const int js_up = 5;
const int A = 6;
const int B = 7;
const int C = 8;
const int D = 9;
const int E = 10;
const int F = 11;
const int blue = 8;
const int yellow = 10;
const int red = 12;
const int green = 13;
int state = one;
void setup() {
  Serial.begin(115200);
  mySwitch.enableReceive(0);
  // Receiver on interrupt 0 => that is pin #2
  pinMode(blue, OUTPUT);
  pinMode(yellow, OUTPUT);
  pinMode(red, OUTPUT);
  pinMode(green, OUTPUT);
}

void loop() {
  if (mySwitch.available()) {

    int value = mySwitch.getReceivedValue();

    if(value == js_left)// turn on only blue LED
    { // when joystick is Left
      digitalWrite(blue, HIGH);
      digitalWrite(yellow, LOW);
      digitalWrite(red, LOW);
      digitalWrite(green, LOW);
    }
    else if(value == js_down)// turn on only yellow LED
    { // when joystick is Down
      digitalWrite(blue, LOW);
      digitalWrite(yellow, HIGH);
      digitalWrite(red, LOW);
      digitalWrite(green, LOW);
    }
    else if(value == js_right)// turn on only green LED
    { //when joystick is Right
      digitalWrite(blue, LOW);
      digitalWrite(yellow, LOW);
      digitalWrite(red, LOW);
      digitalWrite(green, HIGH);
    }

    else if(value == js_up) // turn on only red LED
    { // when joystick is Up
      digitalWrite(blue, LOW);
      digitalWrite(yellow, LOW);
      digitalWrite(red, HIGH);
      digitalWrite(green, LOW)
    }
    else if(value == A)// turn on only blue & yellow LED
    { // when button A is pressed
      digitalWrite(blue, HIGH);
      digitalWrite(yellow, HIGH);
      digitalWrite(red, LOW);
      digitalWrite(green, LOW);
    }
    else if(value == B)// turn on only yellow & red LED
    { // when button B is pressed
      digitalWrite(blue, LOW);
      digitalWrite(yellow, HIGH);
      digitalWrite(red, HIGH);
      digitalWrite(green, LOW);
    }

    else if(value == E)// turn on only blue & red LED
    { // when button E is pressed
      digitalWrite(blue, HIGH);
      digitalWrite(yellow, LOW);
      digitalWrite(red, HIGH);
      digitalWrite(green, LOW);
    }
    else if(value == F)// turn on only yellow & green LE
    { // when button F is pressed
      digitalWrite(blue, LOW);
      digitalWrite(yellow, HIGH);
      digitalWrite(red, LOW);
      digitalWrite(green, HIGH);
    }

    else if(value == C)// turn on only red & green LED
    { // when button C is pressed
      digitalWrite(blue, LOW);
      digitalWrite(yellow, LOW);
      digitalWrite(red, HIGH);
      digitalWrite(green, HIGH);
    }
    else if(value == D)// turn on only green & blue LED
    { // when button D is pressed
      digitalWrite(blue, HIGH);
      digitalWrite(yellow, LOW);
      digitalWrite(red, LOW);
      digitalWrite(green, HIGH);
    }
    else if(value == E)// turn on only blue & red LED
    { // when button E is pressed
      digitalWrite(blue, HIGH);
      digitalWrite(yellow, LOW);
      digitalWrite(red, HIGH);
      digitalWrite(green, LOW);
    }

    else// turn off all leds
    { //when joystick is in middle position
      // and no buttons are pressed
      digitalWrite(blue, LOW);
      digitalWrite(yellow, LOW);
      digitalWrite(red, LOW);
      digitalWrite(green, LOW);
    }
    mySwitch.resetAvailable();
  }
}

```

Figure 51: Controller Testing Code for Receiver

The DC motors and winch have been ordered but are in the processing of being delivered. These components will be controlled with a motor driver that will turn the motors on and off with their desired power. The motor driver is controlled by an Arduino microcontroller. These motors will be operated using Pulse Width Modulated (PWM) signals. The way a PWM signal works is shown in Figure 52. Code has been written to test the motors and is depicted in Figure 53. This code is set for a PWM signal of 25% duty cycle. The code uses user input (from a joystick) to rotate a motor in each direction depending on the input. We will test the motors with this code while the motors have no load, simply to test their functionality. Once they work, the only testing needed would be to find the appropriate duty cycle percentage. To do that, the motors will have to be tested with the load they will each have and the duty cycle must be increased or decreased depending on the motors performance. The two DC motors will operate at 22.2 volts and the winch will operate at 24 volts. The winch will be marked as functional once it can successfully manipulate the telescoping pole upward and downward. The DC motors will pass their tests when one of them can successfully traverse the ring left and right, and the other motor can successfully give the saw forward and backwards translation.

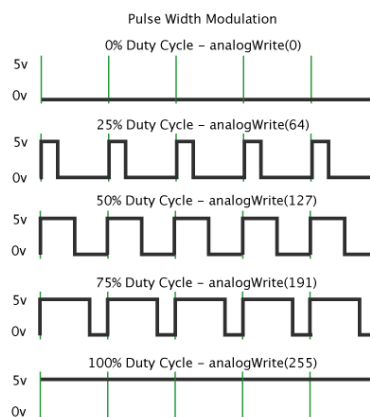

**Figure 52: Graph Definition of PWM**

```

const int hundred = 100;
const int nine_hundred = 900;
const int sixty_four = 64;
const int zero = 0;
const int motor_1_red = 5;
const int motor_1_black = 6;
const int motor_2_red = 9;
const int motor_2_black = 10;

void setup() {
  Serial.begin(115200);
  pinMode(motor_1_red, OUTPUT);
  pinMode(motor_1_black, OUTPUT);
  pinMode(motor_2_red, OUTPUT);
  pinMode(motor_2_black, OUTPUT);
}

void loop() {
  int sensorValx = analogRead(A0);
  int sensorValy = analogRead(A2);

  if(sensorValx < hundred)// joystick left
  { // Motor 1 turn right at 25% duty cycle
    analogWrite(motor_1_red, zero);
    analogWrite(motor_1_black, sixty_four);
    analogWrite(motor_2_red, zero);
    analogWrite(motor_2_black, zero);
  }
  else if(sensorValy < hundred)//joystick down
  { // Motor 2 turn left at 25% duty cycle
    analogWrite(motor_1_red, zero);
    analogWrite(motor_1_black, zero);
    analogWrite(motor_2_red, sixty_four);
    analogWrite(motor_2_black, zero);
  }
  else if(sensorValy > nine_hundred)//joystick up
  { // Motor 2 turn right at 25% duty cycle
    analogWrite(motor_1_red, zero);
    analogWrite(motor_1_black, zero);
    analogWrite(motor_2_red, zero);
    analogWrite(motor_2_black, sixty_four);
  }
  else //joystick middle
  { // Both Motors off
    analogWrite(motor_1_red, zero);
    analogWrite(motor_1_black, zero);
    analogWrite(motor_2_red, zero);
    analogWrite(motor_2_black, zero);
  }
}

```

**Figure 53: Testing Code for DC Motors and Winch**

The stepper motor will also be controlled by a motor driver and the motor driver will be controlled by an Arduino microcontroller. The testing for a stepper motor is different than the DC motors. Since the stepper turns by making the internal magnets step one at a time, digital signals will be used instead of PWM signals. Therefore, the stepper motor has been tested without a load. This circuit is depicted in Figure 54. It will then be tested within the system with its load. The biggest challenge with testing the stepper motor will not be how it is controlled, but rather how it is physically set up instead of the system. This stepper motor will operate at 12 volts. The stepper motor passes its testing once it can successfully pitch the saw up and down. The code used to test the stepper motor is depicted in Figure 55.

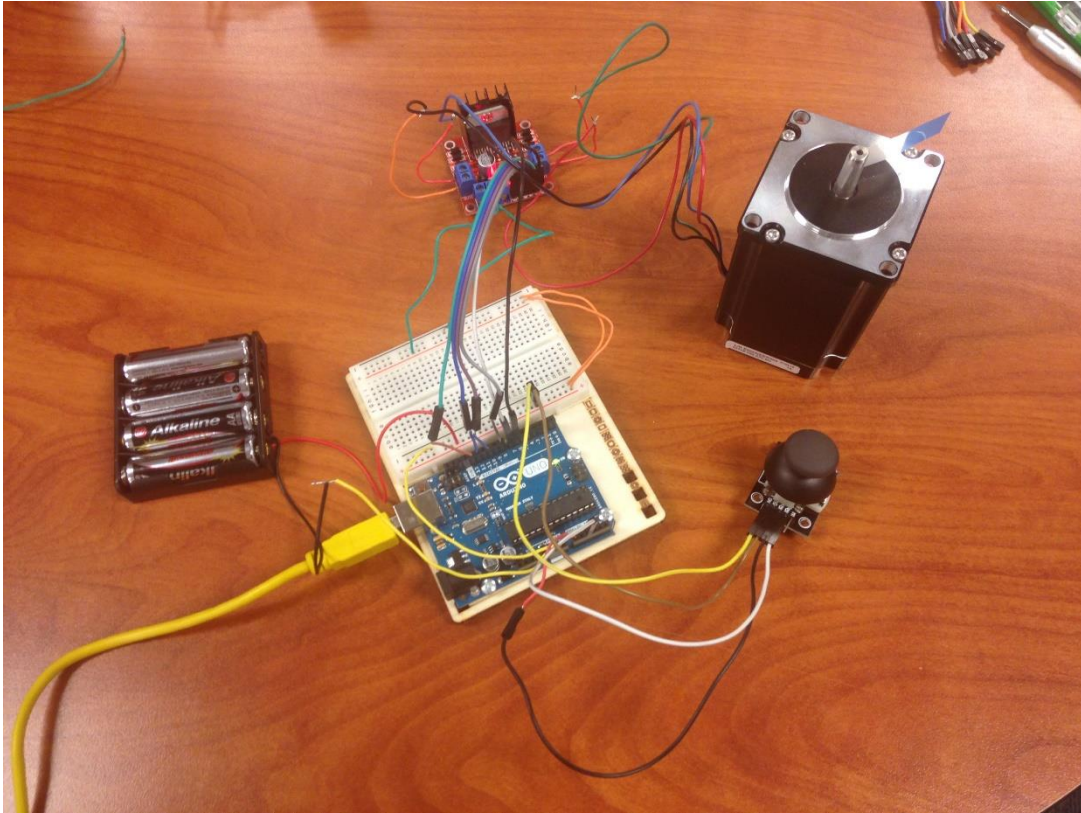

Figure 54: Stepper Motor Testing Circuit

```

const int hundred = 100;
const int nine_hundred = 900;
const int A = 7;
const int B = 8;
const int not_A = 12;
const int not_B = 13;
const int one = 1;
const int two = 2;
const int three = 3;
const int four = 4;
const int five = 5;
const int six = 6;
const int seven = 7;
const int eight = 8;

void setup() {
  Serial.begin(115200);
  pinMode(A, OUTPUT);
  pinMode(B, OUTPUT);
  pinMode(not_A, OUTPUT);
  pinMode(not_B, OUTPUT);
  int state = one;
}

void loop() {
  int sensorValx = analogRead(A0);

  if(sensorValx < hundred//if joystick is left
  {
    // Stepper motor rotates CW
    if(state == one)
    {
      digitalWrite(A, HIGH);
      digitalWrite(B, LOW);
      digitalWrite(not_A, LOW);
      digitalWrite(not_B, LOW);
      state = two;
    }
    else if(state == two)
    {
      digitalWrite(A, HIGH);
      digitalWrite(B, HIGH);
      digitalWrite(not_A, LOW);
      digitalWrite(not_B, LOW);
      state = three;
    }
    else if(state == three)
    {
      digitalWrite(A, LOW);
      digitalWrite(B, HIGH);
      digitalWrite(not_A, LOW);
      digitalWrite(not_B, LOW);
      state = four;
    }
    else if(state == four)
    {
      digitalWrite(A, LOW);
      digitalWrite(B, HIGH);
      digitalWrite(not_A, HIGH);
      digitalWrite(not_B, LOW);
      state = five;
    }
    else if(state == five)
    {
      digitalWrite(A, LOW);
      digitalWrite(B, LOW);
      digitalWrite(not_A, HIGH);
      digitalWrite(not_B, LOW);
      state = six;
    }
  }
}

```



```

else if(state == six)
{
digitalWrite(A, LOW);
digitalWrite(B, LOW);
digitalWrite(not_A, HIGH);
digitalWrite(not_B, HIGH);
state = seven;
}
else if(state == seven)
{
digitalWrite(A, LOW);
digitalWrite(B, LOW);
digitalWrite(not_A, LOW);
digitalWrite(not_B, HIGH);
state = eight;
}
else
{
digitalWrite(A, HIGH);
digitalWrite(B, LOW);
digitalWrite(not_A, LOW);
digitalWrite(not_B, HIGH);
state = one;
}
}

else if(sensorValx > nine_hundred)//if joystick is right //Stepper motor rotates CCW
{
if(state == one)
{
digitalWrite(A, HIGH);
digitalWrite(B, LOW);
digitalWrite(not_A, LOW);
digitalWrite(not_B, LOW);
state = two;
}
else if(state == two)
{
digitalWrite(A, HIGH);
digitalWrite(B, LOW);
digitalWrite(not_A, LOW);
digitalWrite(not_B, HIGH);
state = three;
}
else if(state == three)
{
digitalWrite(A, LOW);
digitalWrite(B, LOW);
digitalWrite(not_A, LOW);
digitalWrite(not_B, HIGH);
state = four;
}
else if(state == seven)
{
digitalWrite(A, LOW);
digitalWrite(B, HIGH);
digitalWrite(not_A, LOW);
digitalWrite(not_B, LOW);
state = eight;
}
else
{
digitalWrite(A, HIGH);
digitalWrite(B, HIGH);
digitalWrite(not_A, LOW);
digitalWrite(not_B, LOW);
state = one;
}
}
else if(state == four)
{
digitalWrite(A, LOW);
digitalWrite(B, LOW);
digitalWrite(not_A, HIGH);
digitalWrite(not_B, HIGH);
state = five;
}
else if(state == five)
{
digitalWrite(A, LOW);
digitalWrite(B, LOW);
digitalWrite(not_A, HIGH);
digitalWrite(not_B, LOW);
state = six;
}
else if(state == six)
{
digitalWrite(A, LOW);
digitalWrite(B, HIGH);
digitalWrite(not_A, HIGH);
digitalWrite(not_B, LOW);
state = seven;
}
}
}

```

**Figure 55: Testing Stepper Motor Code**

The saw is operated by a DC motor. Like the DC motors, this motor will also be controlled by a motor driver. This DC motor differs from all the other motors for multiple reasons. Since this one is designed specifically to drive the saw, PWM signals will not be used and digital signals will be used instead. This motor, unlike the others, only needs to spin in one direction which simplifies the code even further. The code for this is shown below in Figure 56. The functionality of this system will be successful once the saw can be toggled on and off, through the push of a button on the controller.

```

const int button_A = 2;
const int saw = 10;
void setup() {
  Serial.begin(115200);
  pinMode(button_A, INPUT);
  pinMode(saw, OUTPUT);
}

void loop() {
  if(button_A == HIGH)
    digitalWrite(saw, HIGH);
  else
    digitalWrite(saw, LOW);
}

```

Figure 56: Saw Testing Code

Once every individual component has passed all of its tests, the whole system can be tested together. The complete cutting mechanism system will be tested on its own before being lifted up by the telescoping pole. When the cutting mechanism system can successfully traverse the ring left and right, pitch the saw up and down, provide forwards and backward translation of the saw, and turn the saw on and off, it is then ready to be attached to the poling. The first time the cutting mechanism is sent upward, the blade of the saw will be detached for extra safety. Once every single function seems to operate correctly, the saw blade can then be reattached and every function of the system will be tested once again.

## 6. Business Analysis

### 6.1 Economic Analysis

Last year's team was allotted a budget of \$2,500 to build an oil palm harvesting device [9]. However, this device did not meet the customer's requirements, because it was not portable. The team is tasked with designing a portable harvesting device with the same budget of \$2,500. If more money is required to complete the design, the sponsor is willing to expand the budget.

Maintenance costs of any harvesting device will be discussed in future reports, after materials are selected and the prototype's functionality is tested. Despite the high initial cost of purchasing a mechanical harvesting device, the product should cost less to maintain than the annual salary of a worker. Data for Malaysian workers were used to calculate the return on investment, since Malaysia is a leading producer of oil palm fruit [3]. These calculations assume that a Malaysian worker earns a minimum wage of \$297 per month, oil palm plantations contain hundreds of trees, oil palms are harvested daily for eight hours [2], and that the device would be sold for \$2,000 (Table 1). The calculations shown in Appendix A yield a return on investment of 78.20%, which means that the long-term labor savings outweigh the high initial purchase price. Currently, the only money lost to current harvesting methods involves the equipment and human labor required to climb trees and manually cut fruit bunches [2]. This section may be updated in future reports with more information, once further analysis is completed.

## **6.2 Environmental Impact**

When creating a final design, the team considered various outcomes to reduce the environmental impact of the design. The team has selected three manufacturing processes to complete the design: water jetting, additive printing and rolling. None of the selected manufacturing processes directly affect the environment. While production will involve the mechanical assembly of modeled parts, no components will be made from toxic or caustic materials. A variety of batteries were selected as the energy source for the final device, if handled with care, it is unlikely that they will transfer any hazardous waste to the surrounding environment. The main environmental concern for this project is damaging the oil palm tree while the harvesting device is used. The selected design does not attach to the palm tree in any way, which avoids any puncturing of the tree's trunk. Thus, only applied, concentrated, and fixed

forces should exist in the prototype, to ensure that the device will not damage the oil palm tree when being operated.

### **6.3 Ethical Considerations**

Since the device will increase the palm harvesting efficiency, fewer workers would be required to do the task. This situation could cause lower employment. There is another cost to using any efficient oil palm harvesting device, because increasing oil palm fruit production is directly related to increasing deforestation [11]. Deforestation poses a threat to the endangered species that inhabit the rainforests in these areas [11]. Any documentation our team creates for the final device will inform the operator that there is a tradeoff between increasing oil palm fruit production and decreasing deforestation. This section may be updated in future phases with more ethical issues that may arise once the prototype is assembled and tested.

### **6.4 Health and Safety**

The target weight for the device is less than 300 pounds, to prevent workers from becoming fatigued. All electrical components will be located inside of a waterproof box to reduce the risk of electrocution. Since the selected design will be controlled far from the base of an oil palm tree, there is a low risk of any cutting mechanism or fruit bunches falling on a worker. Any selected cutting mechanism will have a regulated speed to ensure that it remains stable during operation. Table 31 depicts ergonomic risk factors for workers on oil palm plantations [32]. Once the design is finalized and the prototype is assembled, this section may be expanded with more details.

**Table 31: Ergonomic Risk Factors on Oil Palm Plantations [32]**

Commonly affected body part/region (potential MSDs)	Task movement / Ergonomic risk factors	References
Neck disorders	Repetitive work	NIOSH (1997); Walker-Bone & Palmer (2002); Rosecrance <i>et al.</i> (2006); Davis (2007); Osborne <i>et al.</i> (2010); Fathallah (2010)
	Forceful work	
	Static contraction	
	Extreme working postures	
Shoulder disorders	Repeated or sustained exertions	NIOSH (1997); Walker-Bone & Palmer (2002); Rosecrance <i>et al.</i> (2006); Davis (2007); Osborne <i>et al.</i> (2010); Fathallah (2010)
	Forceful exertion	
	Awkward or sustained posture (shoulder flexion or abduction)	
Elbow disorders such as epicondylitis	Forceful exertion	NIOSH (1997); Davis (2007); Fathallah (2010)
	Repetition	
	Extreme postures	
Hand/wrist tendonitis such as carpal tunnel syndrome	Repetition	NIOSH (1997); Walker-Bone & Palmer (2002); Davis (2007); Osborne <i>et al.</i> (2010); Fathallah (2010)
	Forceful exertion	
	Awkward posture	
Low back disorders	Heavy physical work	NIOSH (1997); Walker-Bone & Palmer (2002); Rosecrance <i>et al.</i> (2006); Osborne <i>et al.</i> (2010); Davis (2007); Fathallah (2010); Lee (2012)
	Lifting and forceful movements	
	Bending and twisting (awkward postures) such as stooping	
	Whole-body vibration	
	Static work postures	
Knee pain (including osteoarthritis)	Kneeling	Walker-Bone & Palmer (2002); Davis (2007); Osborne <i>et al.</i> (2010); Lee (2012)
	Squatting	
	Prolonged standing	
Ankle / foot pain	Prolonged standing	Walker-Bone & Palmer (2002); Davis (2007) Osborne <i>et al.</i> (2010)
	Static posture	

## 6.5 Social and Political Considerations

Oil palm fruit harvesters in developing countries would benefit from an electromechanical harvesting device; farmers would be able to harvest more fruit for a lower cost and increase profits, because the harvesting process would be efficient, simple, and safe. If the oil palm harvesting process is improved, more individuals in developing countries may wish to purchase the harvesting device. However, since the demand for palm oil is inelastic [33], the demand for palm oil would not necessarily increase.

However, there will end up being a surplus of workers competing for an even smaller number of jobs, which could actually increase the unemployment rate of oil palm harvesters [34]. This may cause social resentment among oil palm workers, because some individuals will inevitably be terminated, while their coworkers will remain employed. Since workers have to compete against each other to avoid termination, their relationship with management can be affected. This section may be updated in the future with more information regarding additional social and political considerations, once the implementation plan for any finalized design is completed.

## **6.6 Sustainability**

The sustainability of any oil palm fruit-harvesting device is heavily dependent on the materials' strength, durability, and the number of electromechanical components. The strength of the materials used in the device and its durability will affect the product's life cycle. For example, the device must be able to resist oxidation in a moist rainforest environment. Furthermore, minimizing the number of components will result in fewer parts that need to be replaced throughout the product's life cycle. Once the prototype is assembled and tested, more information regarding the sustainability of the design may be added to this section.

## **7. Project Progress**

### **7.1 Milestones and Schedule**

#### **7.1.1 Define Phase Tasks**

Major tasks that are required to be completed by the end of the Design Phase are discussed in Table 32. Figure 57 depicts the network flow diagram for the Design Phase, which includes the specific tasks necessary to complete the ones given in Table 32. Quantitative

information regarding the specific tasks for the Define Phase depicted in Figure 57 is given in Table 33.

**Table 32: Major Tasks for the Define Phase**

Task	Explanation
Writing the group's team contract.	This task ensures all team members agree on the policies and procedures that will be used throughout this project.
Contacting and meeting with Dr. Okoli.	This task allows the team to obtain the sponsor's customer requirements and demands for the oil palm fruit harvesting device.
Making a voice of the customer diagram.	This task verifies that all of the customer's requirements were successfully understood.
Constructing the house of quality.	This task converts the customer's requirements into technical requirements and determine the most important elements to consider.
Conducting background research.	This task includes conducting background research into past prototypes and design methodology. It also includes researching current oil palm fruit harvesting methods and the variables involved. This task is significant, because a prototype cannot be designed without knowledge of the current harvesting process.
Writing the group's Risk Assessment.	This task ensures the safety of all group members during the construction and testing of any prototype design.
Brainstorming.	This task allows group members to discuss ideas regarding harvesting device designs.
Choosing a design selection deadline.	This task ensures the team receives the necessary materials by the beginning of the Analyze Phase.
Writing the Define Phase report.	This task allows the group to communicate to the sponsor and stakeholders the team's approach to the project and the current status of any design concepts.
Presenting the group's project status.	This task allows the group to demonstrate a firm understanding of the project to the sponsor and stakeholders, as well as provide a synopsis of the Define Phase report.

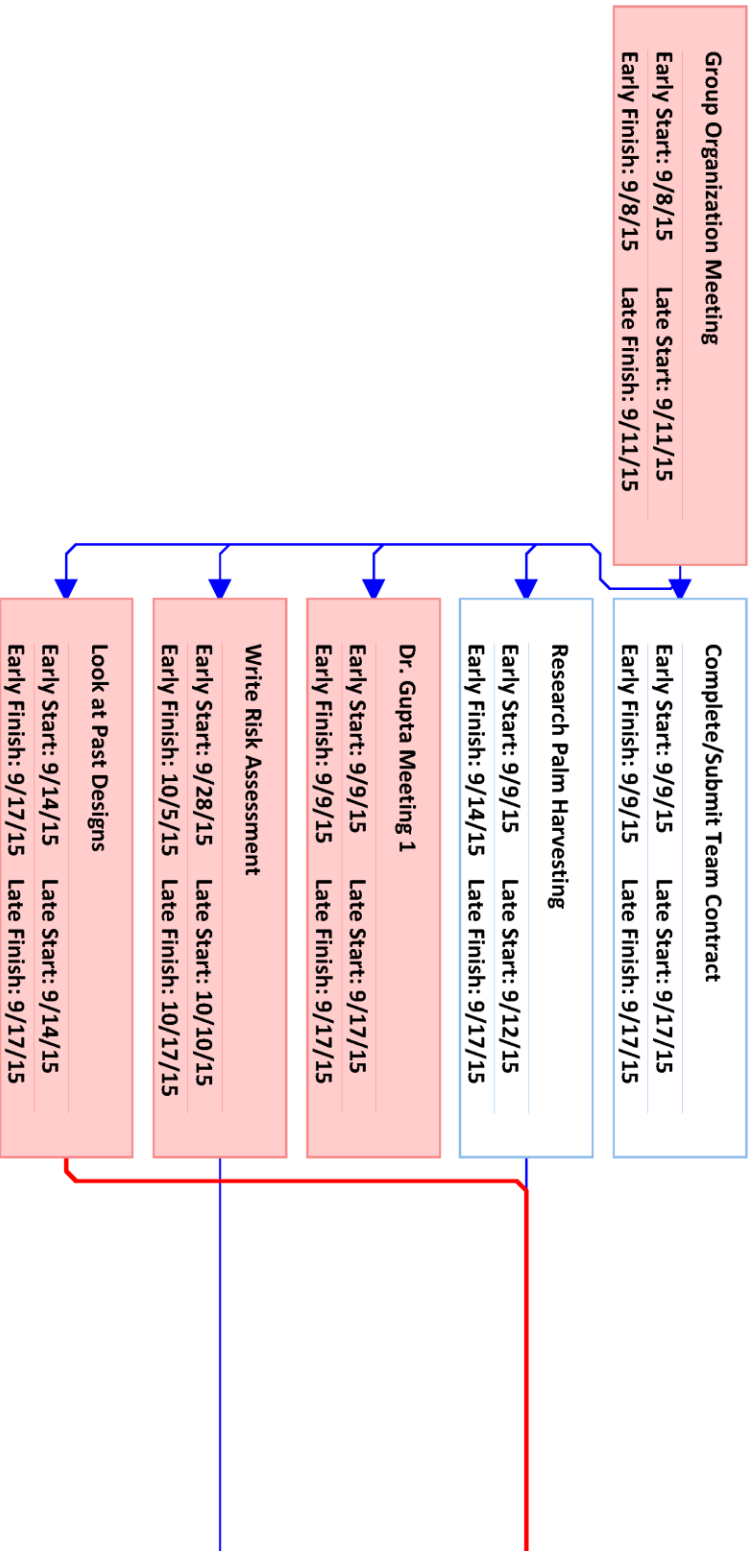



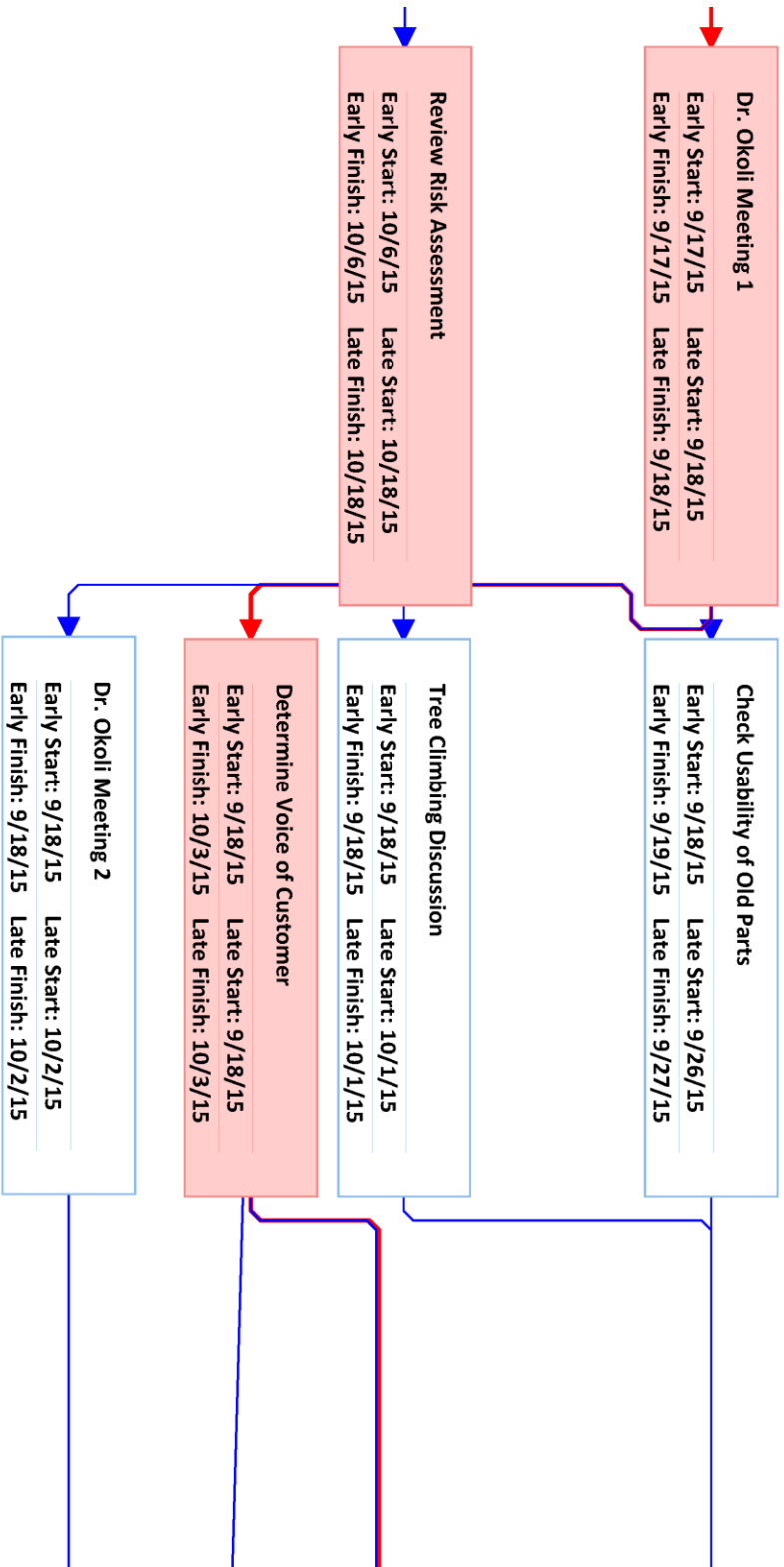

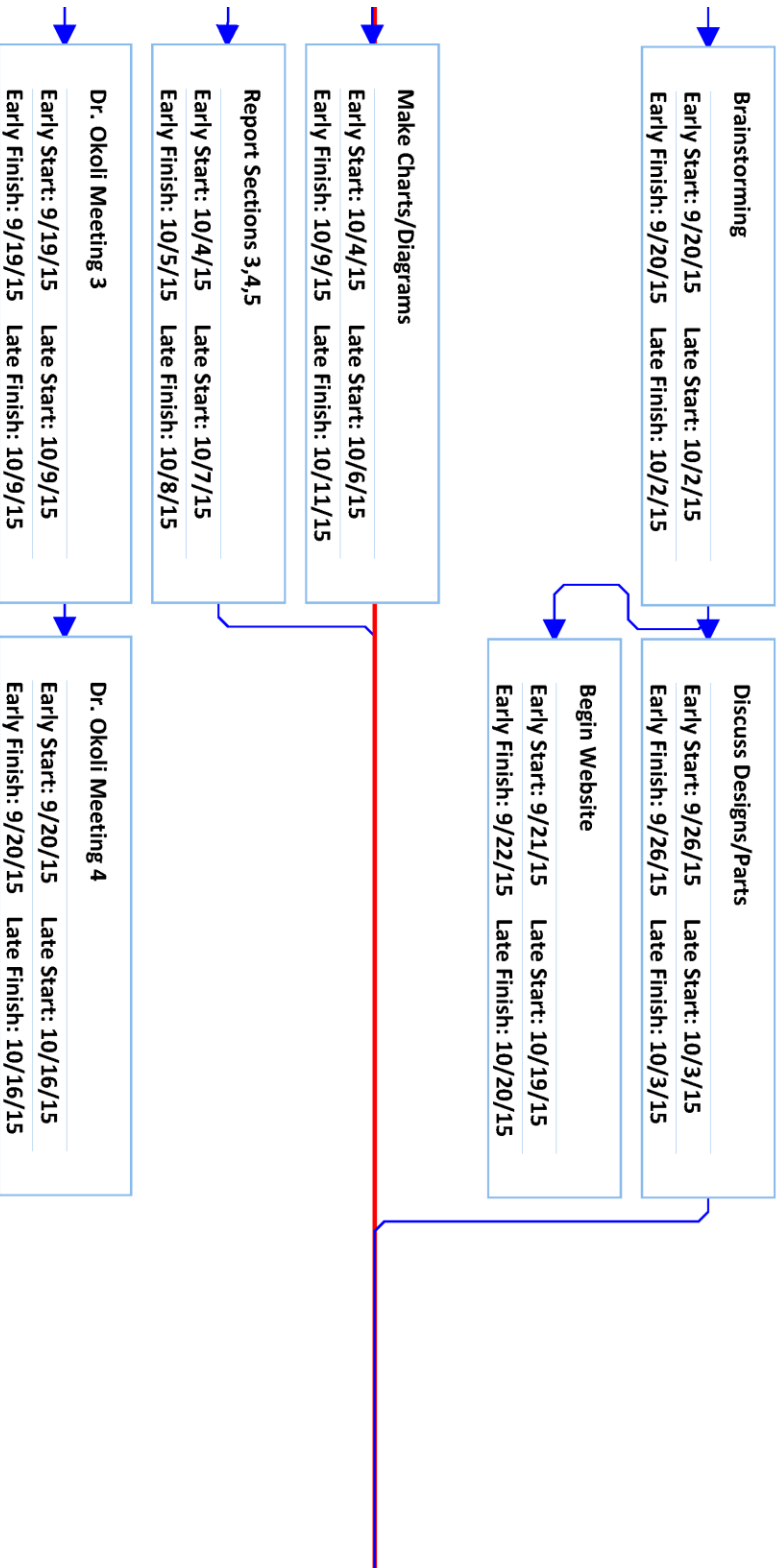

**Report Sections 1,2**  
Early Start: 10/4/15    Late Start: 10/4/15  
Early Finish: 10/8/15    Late Finish: 10/8/15

**Merge Report Sections**  
Early Start: 10/9/15    Late Start: 10/9/15  
Early Finish: 10/11/15    Late Finish: 10/11/15

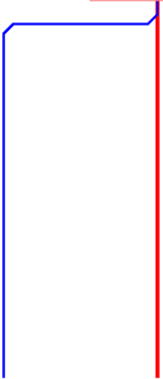

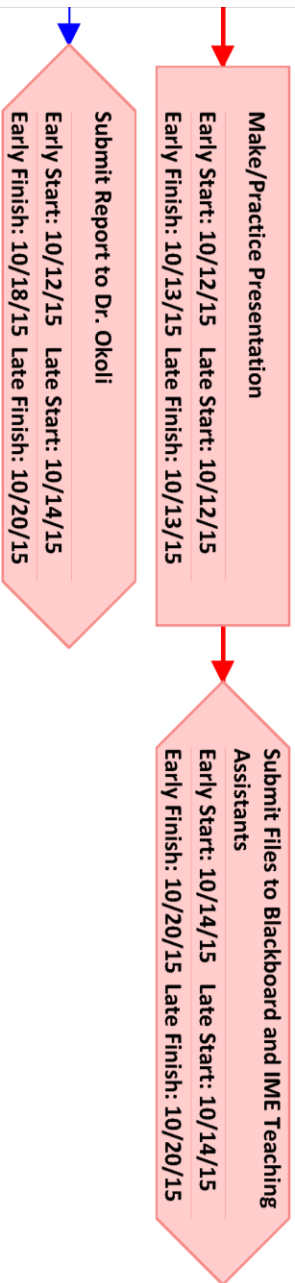

Figure 57: Network Flow Diagram for the Define Phase

**Table 33: Detailed Network Flow Diagram Information for Define Phase Tasks**

Task Name	Start	Finish	Free Slack	Total Slack	Early Start	Early Finish	Late Start	Late Finish
Group Organization Meeting	9/8/15	9/8/15	0 days	3 days	9/8/15	9/8/15	9/11/15	9/11/15
Complete/Submit Team Contract	9/9/15	9/9/15	8 days	8 days	9/9/15	9/9/15	9/17/15	9/17/15
Research Palm Harvesting	9/9/15	9/14/15	3 days	3 days	9/9/15	9/14/15	9/12/15	9/17/15
Dr. Gupta Meeting 1	9/9/15	9/9/15	8 days	8 days	9/9/15	9/9/15	9/17/15	9/17/15
Look at Past Designs	9/14/15	9/17/15	0 days	0 days	9/14/15	9/17/15	9/14/15	9/17/15
Dr. Okoli Meeting 1	9/17/15	9/17/15	0 days	0 days	9/17/15	9/17/15	9/18/15	9/18/15
Check Usability of Old Parts	9/18/15	9/19/15	0 days	8 days	9/18/15	9/19/15	9/26/15	9/27/15
Tree Climbing Discussion	9/18/15	9/18/15	1 day	13 days	9/18/15	9/18/15	10/1/15	10/1/15
Dr. Okoli Meeting 2	9/18/15	9/18/15	0 days	14 days	9/18/15	9/18/15	10/2/15	10/2/15
Determine Voice of Customer	9/18/15	10/3/15	0 days	0 days	9/18/15	10/3/15	9/18/15	10/3/15
Dr. Okoli Meeting 3	9/19/15	9/19/15	0 days	20 days	9/19/15	9/19/15	10/9/15	10/9/15
Dr. Okoli Meeting 4	9/20/15	9/20/15	26 days	26 days	9/20/15	9/20/15	10/16/15	10/16/15
Brainstorming	9/20/15	9/20/15	0 days	12 days	9/20/15	9/20/15	10/2/15	10/2/15
Begin Website	9/21/15	9/22/15	28 days	28 days	9/21/15	9/22/15	10/19/15	10/20/15
Discuss Designs/Parts	9/26/15	9/26/15	7 days	7 days	9/26/15	9/26/15	10/3/15	10/3/15
Write Risk Assessment	9/28/15	10/5/15	0 days	12 days	9/28/15	10/5/15	10/10/15	10/17/15
Report Sections 1,2	10/4/15	10/8/15	0 days	0 days	10/4/15	10/8/15	10/4/15	10/8/15
Make Charts/Diagrams	10/4/15	10/9/15	2 days	2 days	10/4/15	10/9/15	10/6/15	10/11/15
Report Sections 3,4,5	10/4/15	10/5/15	3 days	3 days	10/4/15	10/5/15	10/7/15	10/8/15
Review Risk Assessment	10/6/15	10/6/15	12 days	12 days	10/6/15	10/6/15	10/18/15	10/18/15
Merge Report Sections	10/9/15	10/11/15	0 days	0 days	10/9/15	10/11/15	10/9/15	10/11/15
Make/Practice Presentation	10/12/15	10/13/15	0 days	0 days	10/12/15	10/13/15	10/12/15	10/13/15
Submit Report to Dr. Okoli	10/12/15	10/18/15	2 days	2 days	10/12/15	10/18/15	10/14/15	10/20/15
Submit Files to Bb and TAs	10/14/15	10/20/15	0 days	0 days	10/14/15	10/20/15	10/14/15	10/20/15

Free slack refers to the number of days an activity can be delayed before it delays any succeeding activities, while total slack (also known as float) denotes the number of days an activity can be delayed before it delays the entire project [35]. All activities with a total slack value of zero (0) in Table 33 are along the Define Phase’s critical path, which is denoted by red boxes and arrows in Figure 57. These critical tasks must be completed by the specified deadline,

or the Define Phase will be delayed. Table 33 shows that the first part of the Define Phase's critical path starts on 9/14/15 and ends on 10/20/15. Thus, the critical path of the Define Phase is 36 days.

A Gantt chart of the Define Phase's activities was constructed and is depicted in Figure 58. A Gantt chart is a project management tool used to visualize a project from start to finish. This includes, but it not limited to, a list of all project activities, when each activity begins and finishes, the expected duration of each activity, and where any activities may overlap with one another.

Task Name	9/8	9/9	9/10	9/11	9/12	9/13	9/14	9/15	9/16	9/17	9/18	9/19	9/20	9/21	9/22	9/23	9/24	9/25	9/26	9/27	9/28
Group Organization Meeting	[Bar]																				
Complete/Submit Team Contract	[Bar]																				
Research Palm Harvesting	[Bar]																				
Dr. Gupta Meeting 1	[Bar]																				
Look at Past Designs	[Bar]																				
Dr. Okoli Meeting 1	[Bar]																				
Check Usability of Old Parts	[Bar]																				
Tree Climbing Discussion	[Bar]																				
Dr. Okoli Meeting 2	[Bar]																				
Determine Voice of Customer	[Bar]																				
Dr. Okoli Meeting 3	[Bar]																				
Dr. Okoli Meeting 4	[Bar]																				
Brainstorming	[Bar]																				
Begin Website	[Bar]																				
Discuss Designs/Parts	[Bar]																				
Write Risk Assessment	[Bar]																				
Report Sections 1,2	[Bar]																				
Make Charts/Diagrams	[Bar]																				
Report Sections 3,4,5	[Bar]																				
Review Risk Assessment	[Bar]																				
Merge Report Sections	[Bar]																				
Make/Practice Presentation	[Bar]																				
Submit Report to Dr. Okoli	[Bar]																				
Submit Files to Blackboard and IME Teaching Assistants	[Bar]																				

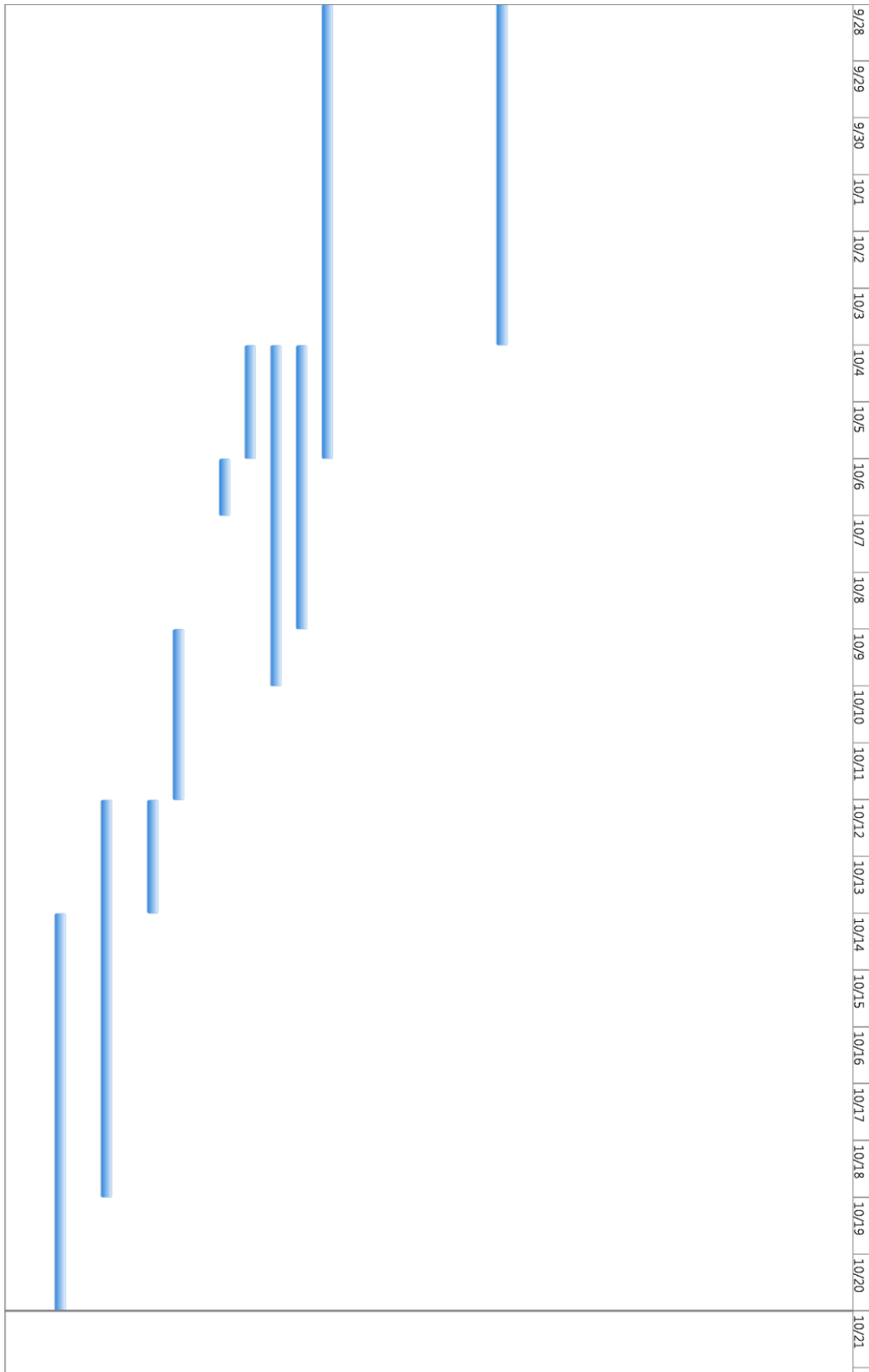

Figure 58: Gantt Chart for the Define Phase



Using Figure 57 and Figure 58, the earliest the Define Phase can end is 10/20/15. The latest the Define Phase can end is also 10/20/15. The reason the early and late finish dates are the same is due to the aforementioned critical path and total slack times, as well as the fact that the Define Phase requires a significant amount of time to ensure all customer requirements are defined properly. In Figure 57 and Figure 58, four days were allotted to submitting the report to the project's stakeholders. If critical tasks are not completed by their late finish deadlines, then the amount of time needed to submit the report at the end of the Define Phase must be reduced. In order to accomplish this task, the team would be required to work in time that was previously not designated for the project.

### **7.1.2 *Measure Phase Tasks***

Major tasks that are required to be completed by the end of the Measure Phase are discussed in Table 34. Figure 59 depicts the network flow diagram for the Measure Phase, which includes the tentative planning of the beginning of the Measure Phase in detail, along with a broader plan of the end of the phase. Quantitative information regarding the specific tasks depicted in Figure 59 is given in Table 35.

**Table 34: Major Tasks for the Measure Phase**

Task	Explanation
Contact and meeting with Dr. Okoli.	This ensures that any designs developed by the group are desirable by the sponsor.
Brainstorming.	Group members discuss ideas regarding harvesting device designs.
Discuss the evolution of the team's designs.	Team members discuss which palm harvesting ideas are feasible, given the time constraints of the project.
Final design selection.	A design that meets the sponsor's requirements must be selected.
Generate three-dimensional design renderings.	This visualizes how the palm harvesting prototype will appear after it is built and allows for any design issues to be identified before construction begins.
Write the Measure Phase report.	This communicates to the sponsor and stakeholders the team's design selection and the steps that must be taken before it is constructed.
Present the group's project status.	This demonstrates that a design was selected and materials were ordered to the sponsor and stakeholders, as well as provide a synopsis of the Measure report.
Order the materials needed for the selected palm harvesting device design.	Makes sure materials arrive to complete a prototype by the end of the project.

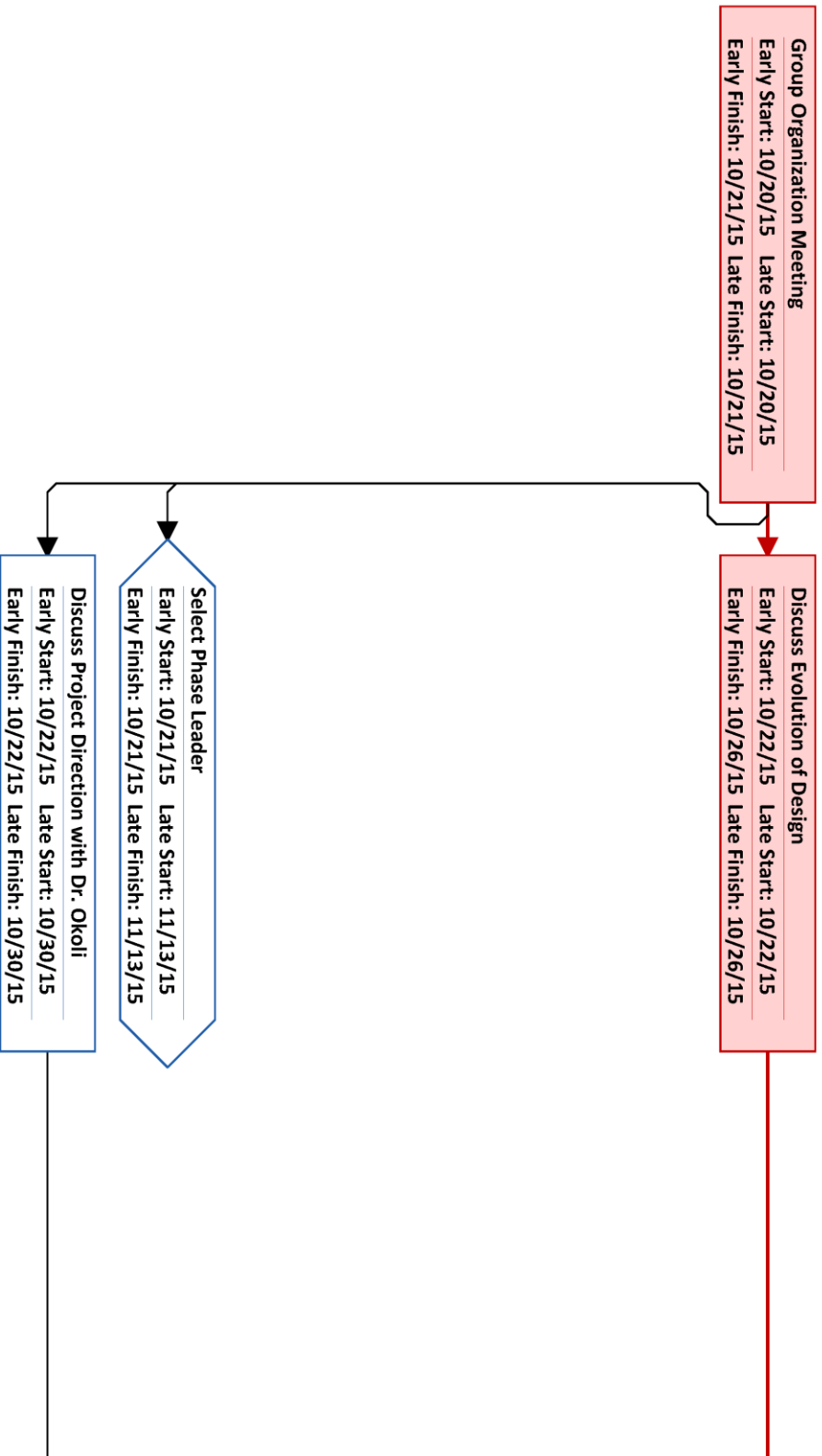

Brainstorm/Develop Design Concepts  
Early Start: 10/27/15 Late Start: 10/27/15  
Early Finish: 11/3/15 Late Finish: 11/3/15

Finish/Select Final Design  
Early Start: 11/4/15 Late Start: 11/4/15  
Early Finish: 11/9/15 Late Finish: 11/9/15

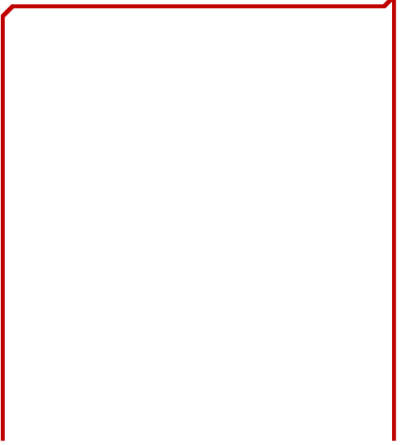

---

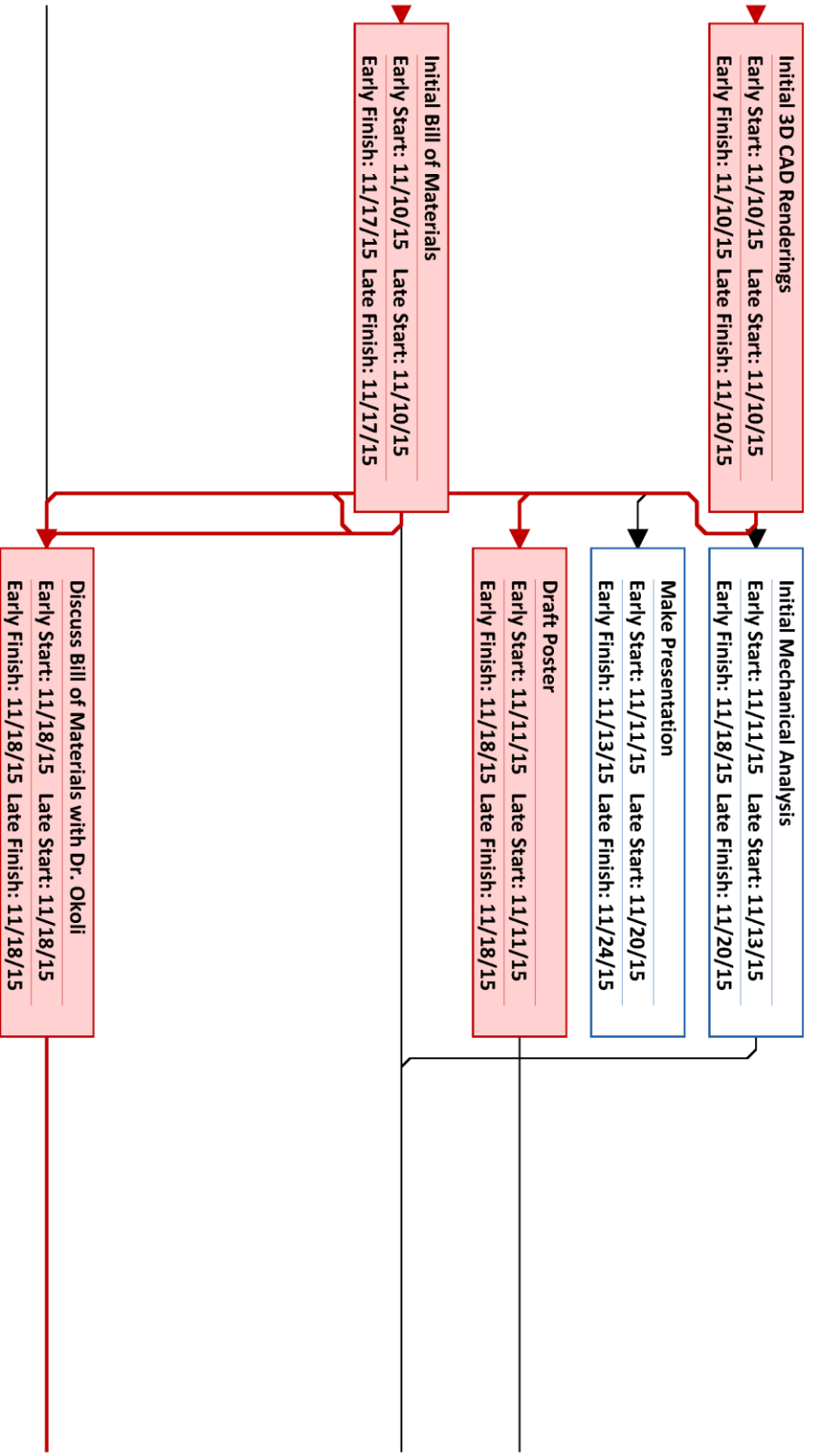

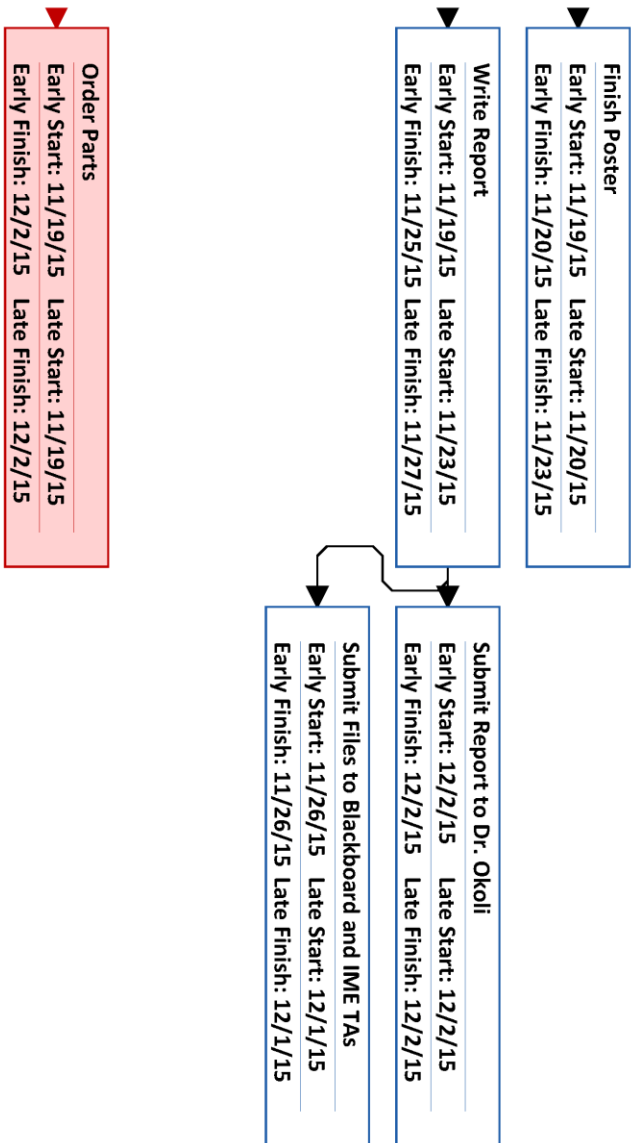

Figure 59: Network Flow Diagram for the Measure Phase

**Table 35: Detailed Network Flow Diagram Information for Measure Phase Tasks**

Task Name	Start	Finish	Free Slack	Total Slack	Early Start	Early Finish	Late Start	Late Finish
Group Organization Meeting	10/20/15	10/21/15	0 days	0 days	10/20/15	10/21/15	10/20/15	10/21/15
Select Phase Leader	10/21/15	10/21/15	17 days	17 days	10/21/15	10/21/15	11/13/15	11/13/15
Discuss Project Direction with Dr. Okoli	10/22/15	10/22/15	6 days	6 days	10/22/15	10/22/15	10/30/15	10/30/15
Discuss Evolution of Design	10/22/15	10/26/15	0 days	0 days	10/22/15	10/26/15	10/22/15	10/26/15
Brainstorm/Develop Design Concepts	10/27/15	11/3/15	0 days	0 days	10/27/15	11/3/15	10/27/15	11/3/15
Finish/Select Final Design	11/4/15	11/9/15	0 days	0 days	11/4/15	11/9/15	11/4/15	11/9/15
Initial 3D CAD Renderings	11/10/15	11/10/15	0 days	0 days	11/10/15	11/10/15	11/10/15	11/10/15
Initial Bill of Materials	11/10/15	11/17/15	0 days	0 days	11/10/15	11/17/15	11/10/15	11/17/15
Draft Poster	11/11/15	11/18/15	0 days	0 days	11/11/15	11/18/15	11/11/15	11/18/15
Initial Mechanical Analysis	11/11/15	11/18/15	0 days	2 days	11/11/15	11/18/15	11/13/15	11/20/15
Make Presentation	11/11/15	11/13/15	7 days	7 days	11/11/15	11/13/15	11/20/15	11/24/15
Discuss Bill of Materials with Dr. Okoli	11/18/15	11/18/15	0 days	0 days	11/18/15	11/18/15	11/18/15	11/18/15
Finish Poster	11/19/15	11/20/15	1 day	1 day	11/19/15	11/20/15	11/20/15	11/23/15
Write Report	11/19/15	11/25/15	0 days	2 days	11/19/15	11/25/15	11/23/15	11/27/15
Order Parts	11/19/15	12/2/15	0 days	0 days	11/19/15	12/2/15	11/19/15	12/2/15
Submit Files to Blackboard and IME TAs	11/26/15	11/26/15	3 days	3 days	11/26/15	11/26/15	12/1/15	12/1/15
Submit Report to Dr. Okoli	12/2/15	12/2/15	0 days	0 days	12/2/15	12/2/15	12/2/15	12/2/15

Free slack and total slack (float) were discussed in Section 7.1.1. All activities with a total slack value of zero (0) in Table 35 are along the Measure Phase's critical path, which is denoted by red boxes and arrows in Figure 59. These critical tasks must be completed by the specified deadline, or the Measure Phase will be delayed. Table 35 shows that the first part of the Measure Phase's critical path starts on 10/20/15 and ends on 12/2/15. Thus, the critical path of the Measure Phase is 43 days.

Gantt charts were discussed in Section 7.1.1. A Gantt chart of the Measure Phase's planned activities was constructed and is depicted in Figure 60.



Task Name	10/21	10/22	10/23	10/24	10/25	10/26	10/27	10/28	10/29	10/30	10/31	11/1	11/2	11/3	11/4	11/5	11/6	11/7	11/8	11/9
Group Organization Meeting	█																			
Select Phase Leader	█																			
Discuss Project Direction with Dr. Okoli	◆ 10/21 █																			
Discuss Evolution of Design	█																			
Brainstorm/Develop Design Concepts	█																			
Finish/Select Final Design	█																			
Draft Poster	█																			
Initial 3D CAD Renderings	█																			
Finish Poster	█																			
Write Report	█																			
Initial Bill of Materials	█																			
Initial Mechanical Analysis	█																			
Order Parts	█																			
Make Presentation	█																			
Submit Report to Dr. Okoli	█																			
Submit Files to Blackboard and IME TAs	█																			
Discuss Bill of Materials with Dr. Okoli	█																			

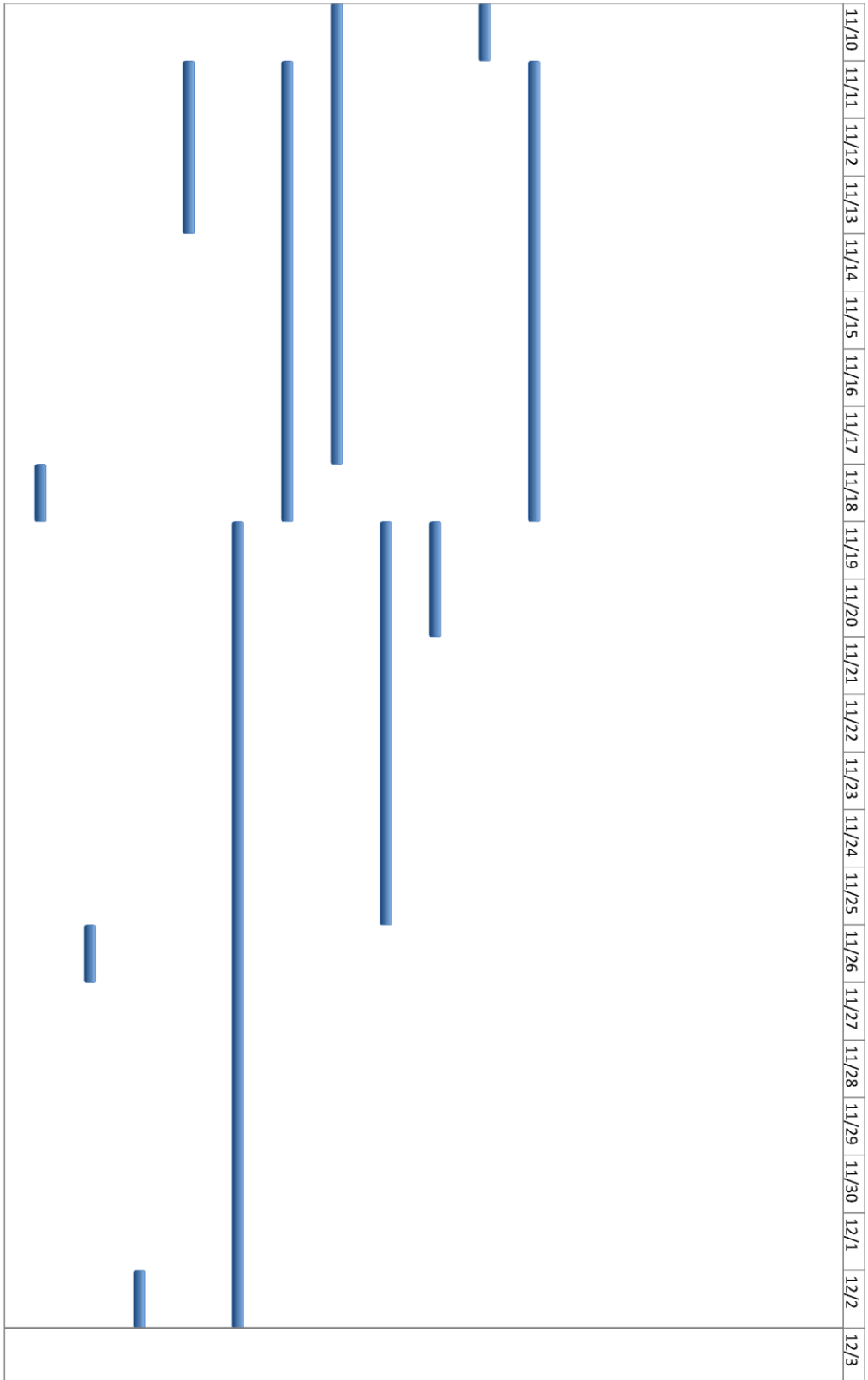

Figure 60: Gantt Chart for the Measure Phase

Using Figure 59 and Figure 60, the earliest the Measure Phase can end is 12/2/15. The latest the Measure Phase can end is also 12/2/15.

### 7.1.3 Analyze Phase Tasks

Major tasks that are required to be completed by the end of the Analyze Phase are discussed in Table 36. Figure 61 depicts the network flow diagram for the Analyze Phase, which includes an outline of the tasks that need to be completed. Quantitative information regarding the specific tasks depicted in Figure 61 is given in Table 37.

**Table 36: Major Tasks for the Analyze Phase**

Task	Explanation
Contacting and meeting with Dr. Okoli.	This ensures that any designs developed by the group do not need any final adjustments before being constructed.
Conduct pole FEA.	FEA on the pole must be conducted to determine if the design is feasible.
Verify design and CAD renderings	Based on the results of the pole FEA, the design and CAD renderings may need to be updated.
Write the Analyze Phase report.	This allows the group to communicate to the sponsor and stakeholders the team's analysis results and any future plans of action.
Present the group's project status.	This allows the group to demonstrate that a design was analyzed, as well as provide a synopsis of the Analyze Phase report.

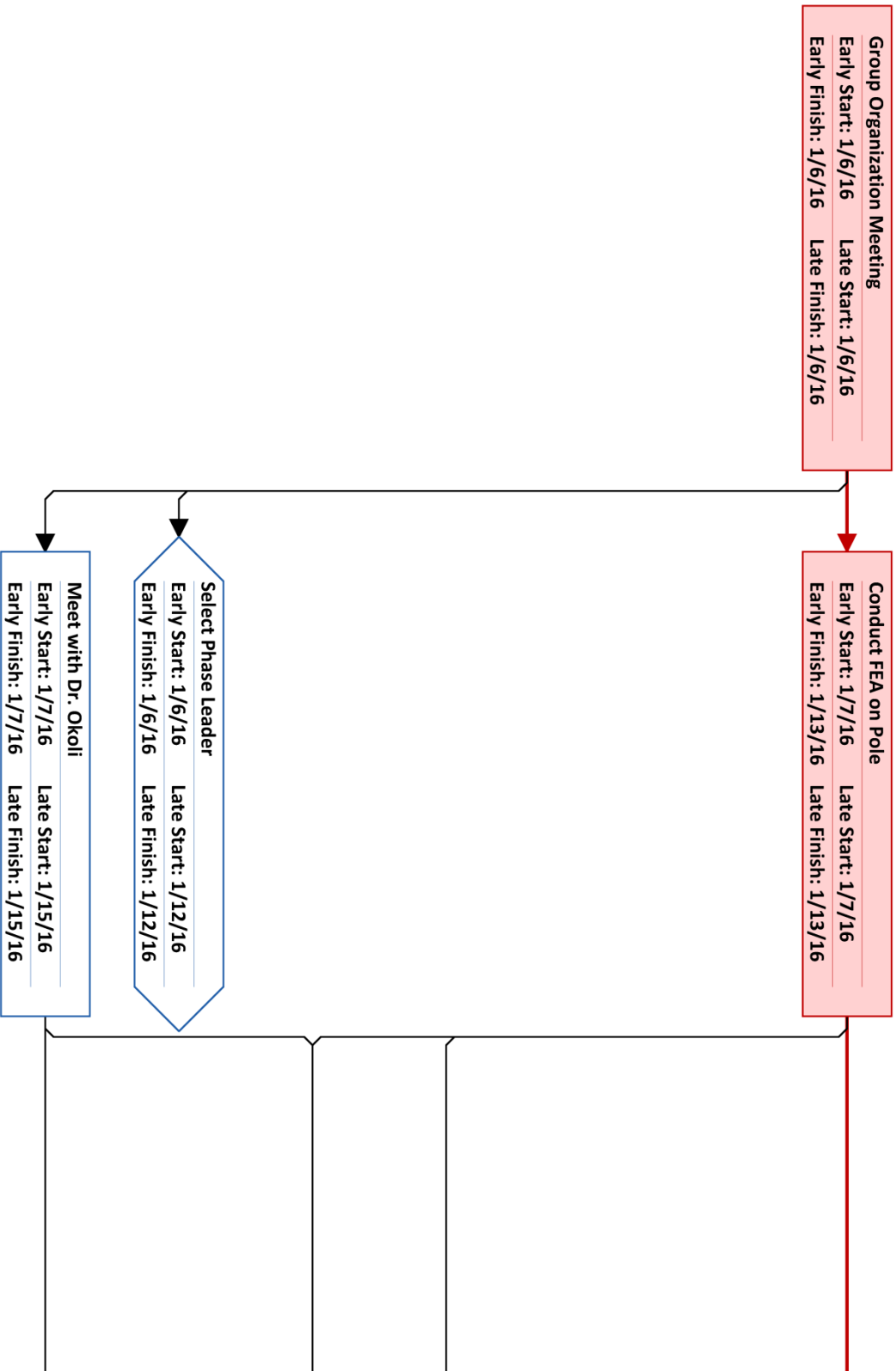

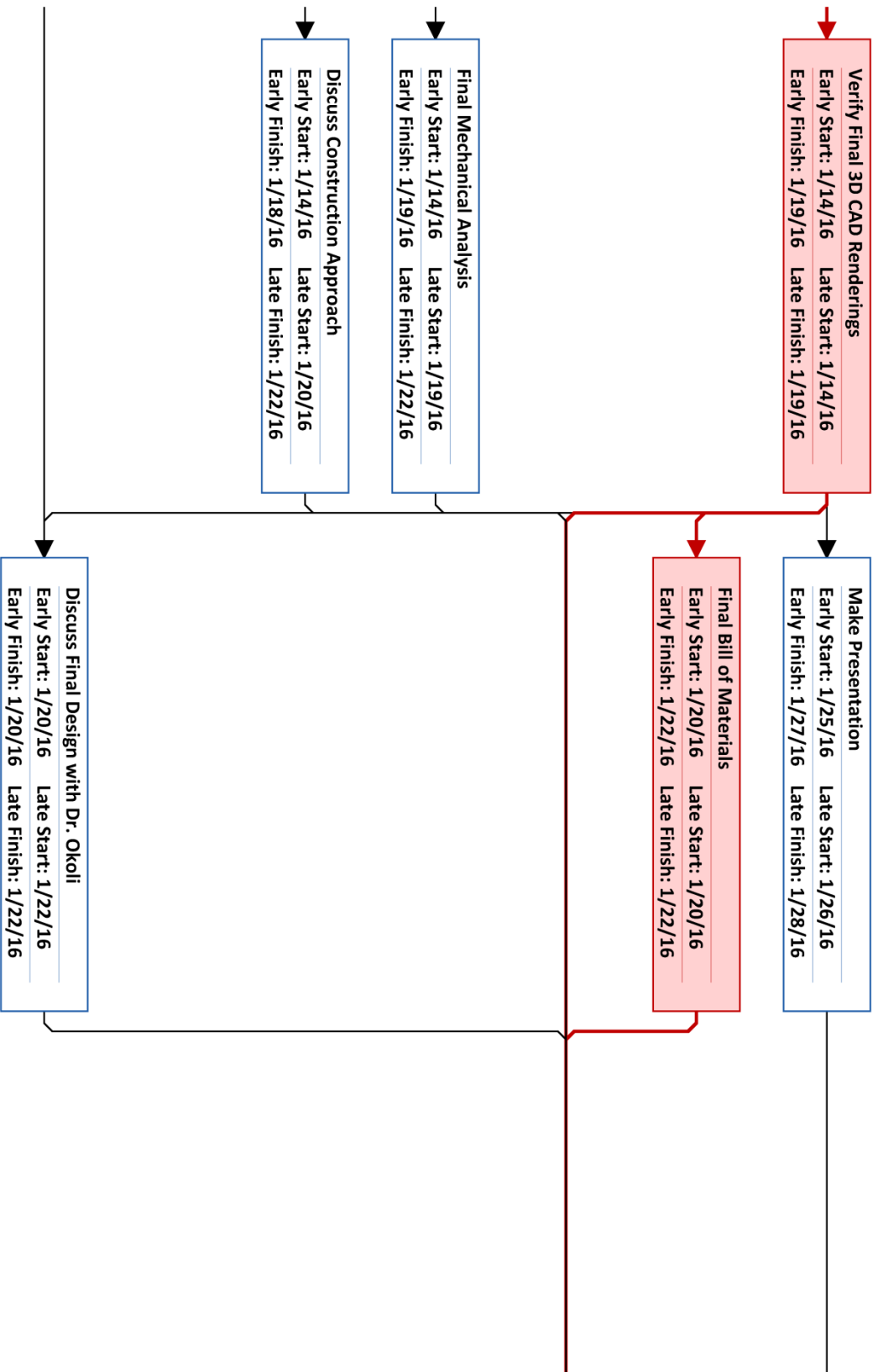

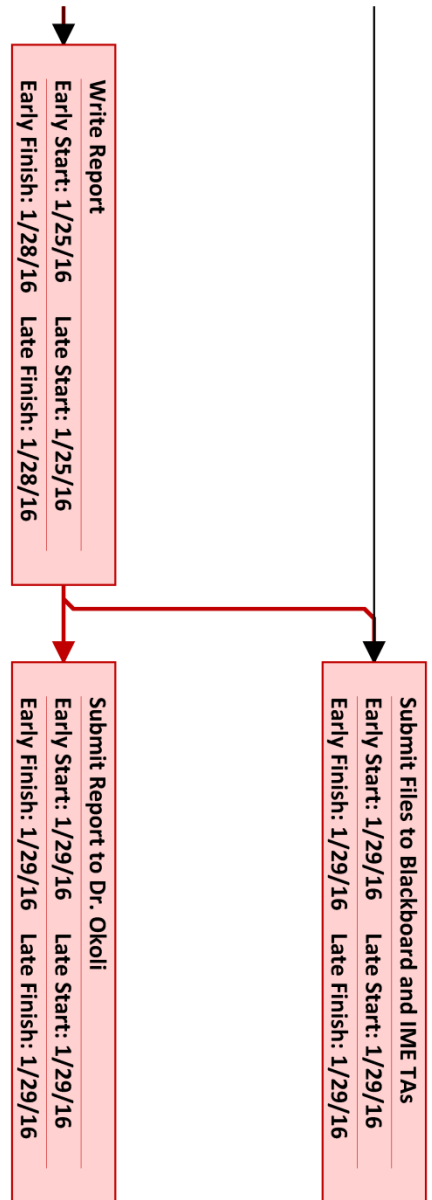

Figure 61: Network Flow Diagram for the Analyze Phase

**Table 37: Detailed Network Flow Diagram Information for Analyze Phase Tasks**

Task Name	Duration	Start	Finish	Free Slack	Total Slack	Early Start	Early Finish	Late Start	Late Finish
Group Organization Meeting	1 day	1/6/16	1/6/16	0 days	0 days	1/6/16	1/6/16	1/6/16	1/6/16
Select Phase Leader	0 days	1/6/16	1/6/16	4 days	4 days	1/6/16	1/6/16	1/12/16	1/12/16
Meet with Dr. Okoli	1 day	1/7/16	1/7/16	6 days	6 days	1/7/16	1/7/16	1/15/16	1/15/16
Conduct FEA on Pole	5 days	1/7/16	1/13/16	0 days	0 days	1/7/16	1/13/16	1/7/16	1/13/16
Discuss Construction Approach	3 days	1/14/16	1/18/16	4 days	4 days	1/14/16	1/18/16	1/20/16	1/22/16
Verify Final 3D CAD Renderings	4 days	1/14/16	1/19/16	0 days	0 days	1/14/16	1/19/16	1/14/16	1/19/16
Final Mechanical Analysis	4 days	1/14/16	1/19/16	3 days	3 days	1/14/16	1/19/16	1/19/16	1/22/16
Final Bill of Materials	3 days	1/20/16	1/22/16	0 days	0 days	1/20/16	1/22/16	1/20/16	1/22/16
Discuss Final Design with Dr. Okoli	1 day	1/20/16	1/20/16	2 days	2 days	1/20/16	1/20/16	1/22/16	1/22/16
Write Report	4 days	1/25/16	1/28/16	0 days	0 days	1/25/16	1/28/16	1/25/16	1/28/16
Make Presentation	3 days	1/25/16	1/27/16	1 day	1 day	1/25/16	1/27/16	1/26/16	1/28/16
Submit Report to Dr. Okoli	1 day	1/29/16	1/29/16	0 days	0 days	1/29/16	1/29/16	1/29/16	1/29/16
Submit Files to Blackboard and IME TAs	1 day	1/29/16	1/29/16	0 days	0 days	1/29/16	1/29/16	1/29/16	1/29/16

Free slack and total slack (float) were discussed in Section 7.1.1. All activities with a total slack value of zero (0) in Table 37 are along the Analyze Phase’s critical path, which is denoted by red boxes and arrows in Figure 61. These critical tasks must be completed by the specified deadline, or the Analyze Phase will be delayed. Table 37 illustrates that the first part of

the Analyze Phase's critical path starts on 1/6/16 and ends on 1/29/16. Thus, the critical path of the Analyze Phase is 23 days. However, this duration is subject to change in the future, depending on the results of the Measure Phase.

Gantt charts were discussed in Section 7.1.1. A Gantt chart of the Measure Phase's planned activities was constructed and is depicted in Figure 62.



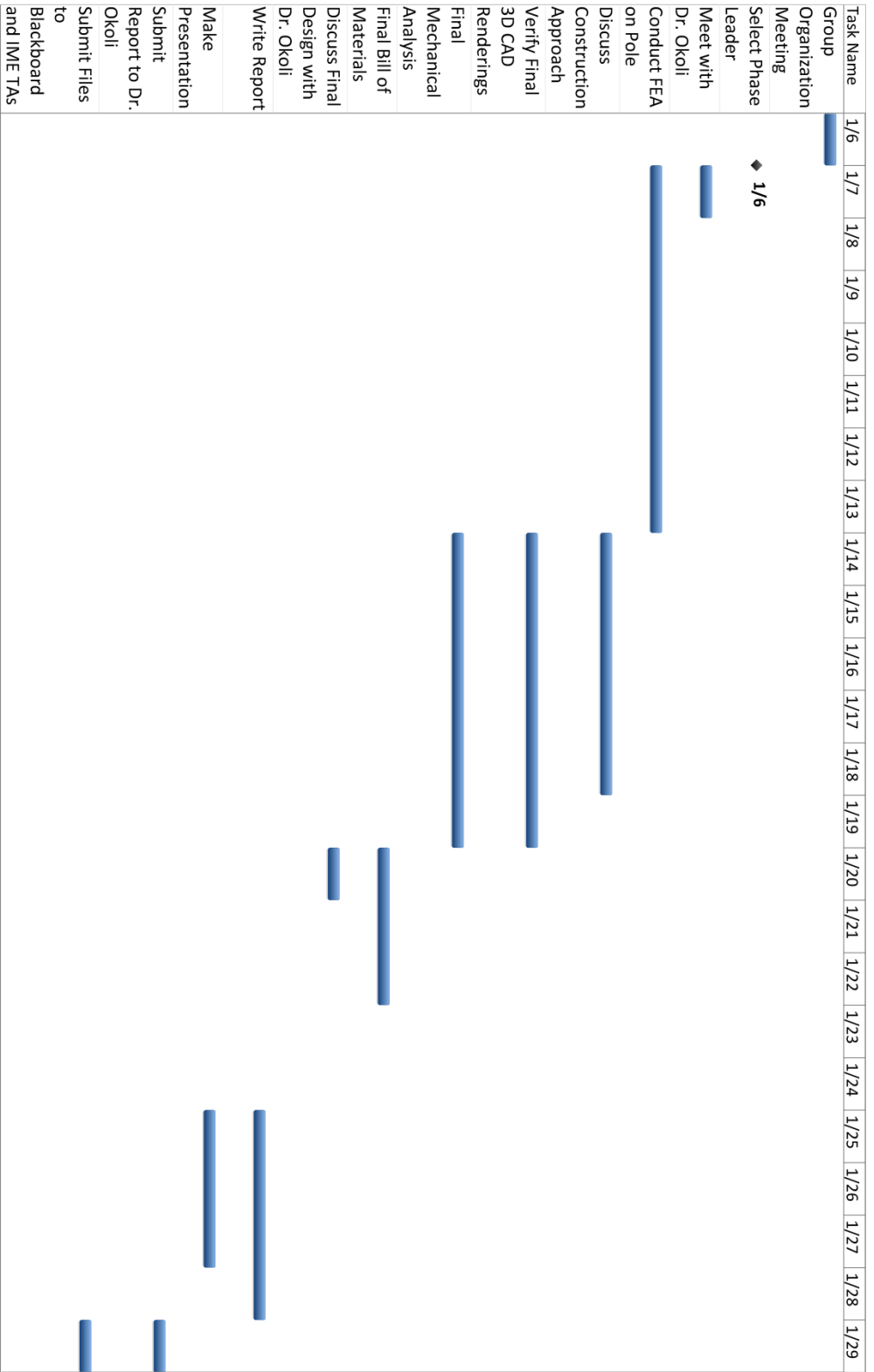

Figure 62: Gantt Chart for the Analyze Phase

Using Figure 61 and Figure 62, the earliest that the Analyze Phase can end is 1/29/16.

The latest the Analyze Phase can end is also 1/29/16.

#### **7.1.4 *Improve Phase Tasks***

Since the Improve Phase has not yet begun, all tasks listed in this subsection are subject to change in the future, based on the team's design process or new instructions from the sponsor. Major tasks that are required to be completed by the end of the Improve Phase are discussed in Table 38. Figure 63 depicts the network flow diagram for the Improve Phase, which includes a broad outline of the tasks that need to be completed. Quantitative information regarding the specific tasks depicted in Figure 63 is given in Table 39.

**Table 38: Major Tasks for the Improve Phase**

Task	Explanation
Contacting and meeting with Dr. Okoli.	The sponsor can inform the group of any changes that are desired to the constructed prototype.
Determine construction schedule.	This allows the group to determine when parts will be built or assembled.
Build ring.	This will involve building the ring mechanism of the design.
Assemble pole.	This will involve building the pole section of the design.
Document progress.	This allows the group to communicate to the sponsor and stakeholders the team's progress on constructing the prototype.
Presenting the group's project status.	This allows the group to demonstrate progress toward a prototype to the sponsor and stakeholders, as well as give a synopsis of the Improve Phase's tasks.

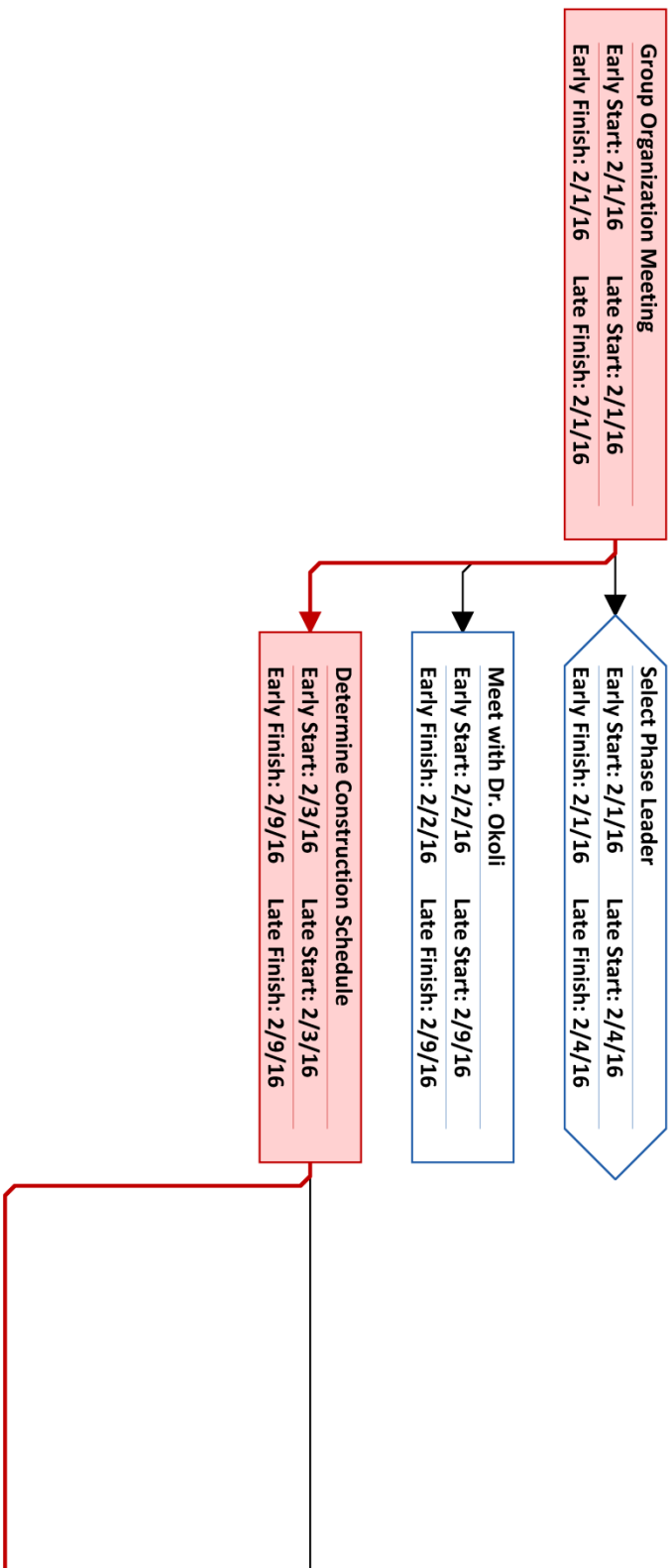

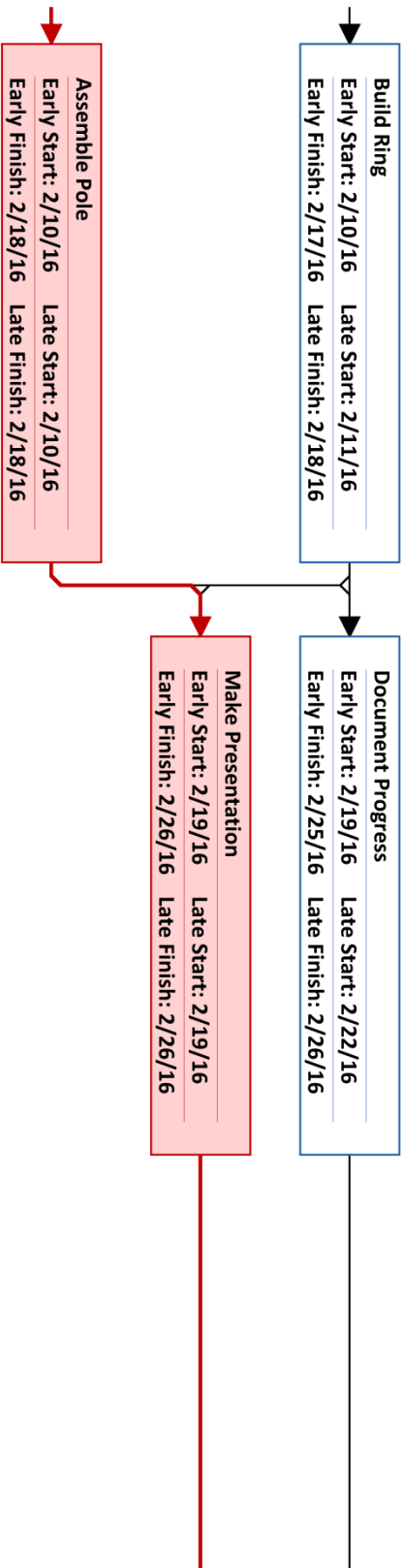

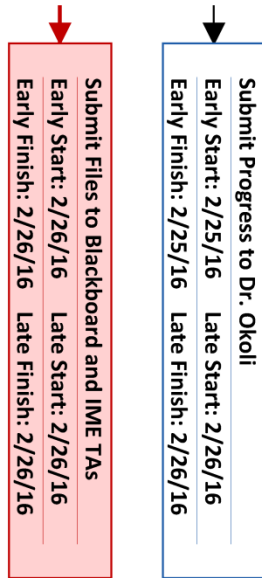

Figure 63: Network Flow Diagram for the Improve Phase

**Table 39: Detailed Network Flow Diagram Information for Improve Phase Tasks**

Task Name	Duration	Start	Finish	Free Slack	Total Slack	Early Start	Early Finish	Late Start	Late Finish
Group Organization Meeting	1 day	2/1/16	2/1/16	0 days	0 days	2/1/16	2/1/16	2/1/16	2/1/16
Select Phase Leader	0 days	2/1/16	2/1/16	2 days	2 days	2/1/16	2/1/16	2/4/16	2/4/16
Meet with Dr. Okoli	1 day	2/2/16	2/2/16	5 days	5 days	2/2/16	2/2/16	2/9/16	2/9/16
Determine Construction Schedule	5 days	2/3/16	2/9/16	0 days	0 days	2/3/16	2/9/16	2/3/16	2/9/16
Build Ring	6 days	2/10/16	2/17/16	1 day	1 day	2/10/16	2/17/16	2/11/16	2/18/16
Assemble Pole	7 days	2/10/16	2/18/16	0 days	0 days	2/10/16	2/18/16	2/10/16	2/18/16
Document Progress	5 days	2/19/16	2/25/16	0 days	1 day	2/19/16	2/25/16	2/22/16	2/26/16
Make Presentation	6 days	2/19/16	2/26/16	0 days	0 days	2/19/16	2/26/16	2/19/16	2/26/16
Submit Progress to Dr. Okoli	0 days	2/25/16	2/25/16	1 day	1 day	2/25/16	2/25/16	2/26/16	2/26/16
Submit Files to Blackboard and IME TAs	0 days	2/26/16	2/26/16	0 days	0 days	2/26/16	2/26/16	2/26/16	2/26/16

Free slack and total slack (float) were discussed in Section 7.1.1. All activities with a total slack value of zero (0) in Table 39 are along the Improve Phase’s critical path, which is denoted by red boxes and arrows in Figure 63. These critical tasks must be completed by the specified deadline, or the Improve Phase will be delayed. Table 39 illustrates that the first part of the Improve Phase’s critical path starts on 2/1/16 and ends on 2/26/16. Thus, the critical path of the Improve Phase is 25 days.

Gantt charts were discussed in Section 7.1.1. A Gantt chart of the Improve Phase’s planned activities was constructed and is depicted in Figure 64.

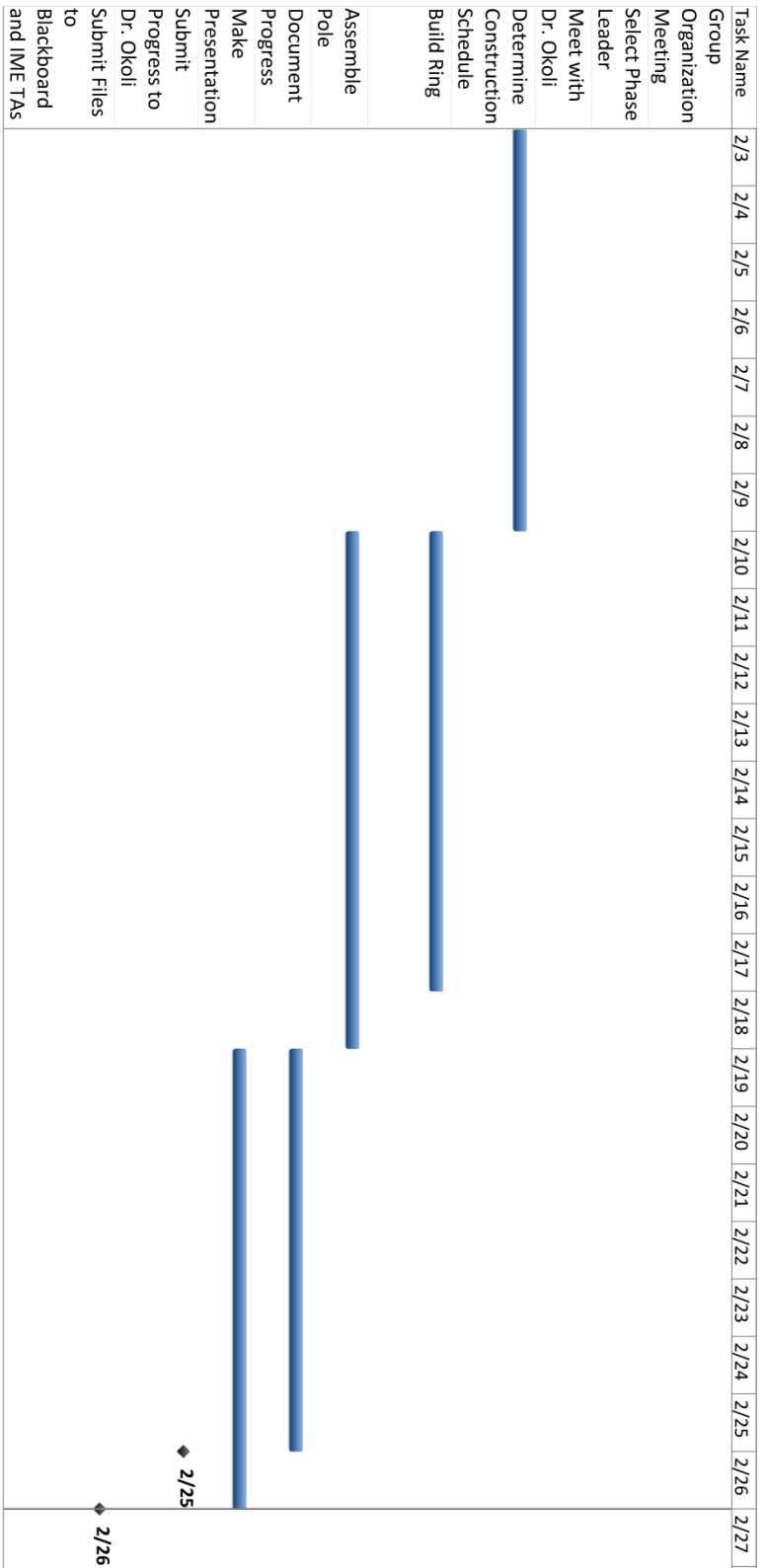

Figure 64: Gantt Chart for the Improve Phase



Using Figure 63 and Figure 64, the earliest the Improve Phase can end is 2/26/15. The latest the Improve Phase can end is also 2/26/16.

### **7.1.5 Control Phase Tasks**

Since the Control Phase has not yet begun, all tasks listed in this subsection are subject to change in the future, based on the team's design process or new instructions from the sponsor. Major tasks that are required to be completed by the end of the Control Phase are discussed in Table 40. Figure 65 depicts the network flow diagram for the Control Phase, which includes a broad outline of the tasks that need to be completed. Quantitative information regarding the tasks in Figure 65 is given in Table 41.

**Table 40: Major Tasks for the Control Phase**

Task	Explanation
Contacting and meeting with Dr. Okoli.	The sponsor can inform the group of any prototype benchmarks that must be met.
Finalize prototype construction.	This allows the group to finish constructing the prototype.
Write prototype manual.	This allows someone that was not a part of the project to be able to learn how to operate the prototype.
Writing the Control Phase report.	This allows the group to communicate to the sponsor and stakeholders the team's final prototype design and specifications.

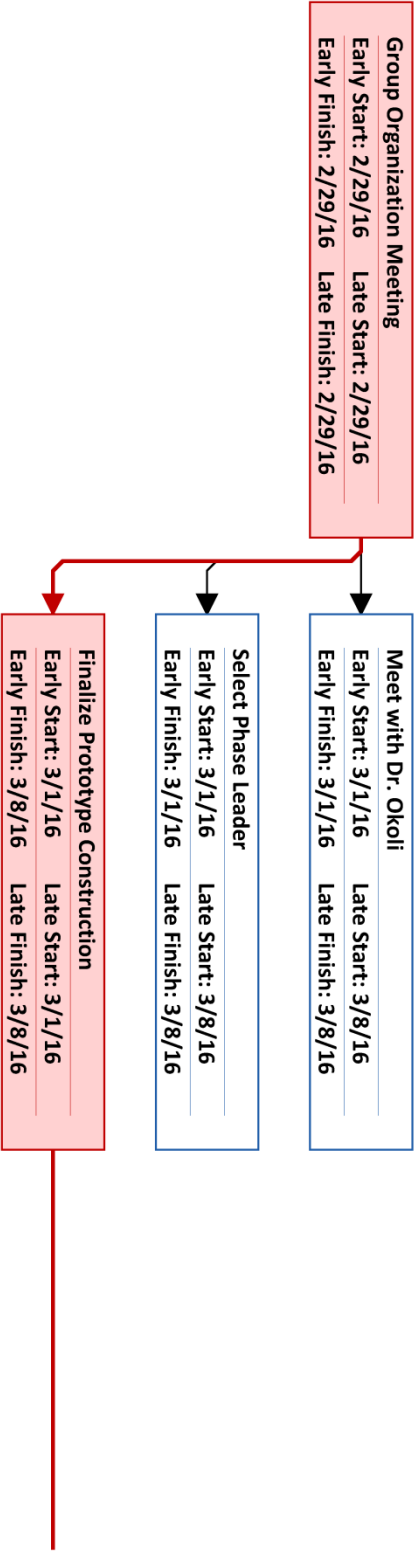

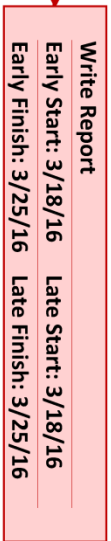
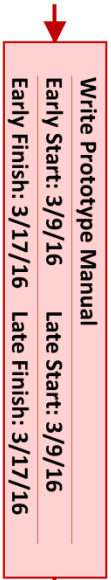

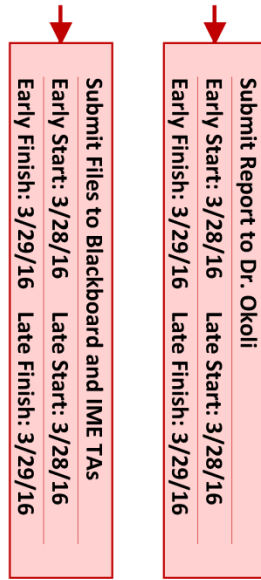

**Figure 65: Network Flow Diagram for the Control Phase**

**Table 41: Detailed Network Flow Diagram Information for Control Phase Tasks**

Task Name	Start	Finish	Free Slack	Total Slack	Early Start	Early Finish	Late Start	Late Finish
Group Organization Meeting	2/29/16	2/29/16	0 days	0 days	2/29/16	2/29/16	2/29/16	2/29/16
Finalize Prototype Construction	3/1/16	3/8/16	0 days	0 days	3/1/16	3/8/16	3/1/16	3/8/16
Write Prototype Manual	3/9/16	3/17/16	0 days	0 days	3/9/16	3/17/16	3/9/16	3/17/16
Write Report	3/18/16	3/25/16	0 days	0 days	3/18/16	3/25/16	3/18/16	3/25/16
Submit Report to Dr. Okoli	3/28/16	3/29/16	0 days	0 days	3/28/16	3/29/16	3/28/16	3/29/16
Submit Files to Blackboard and IME TAs	3/28/16	3/29/16	0 days	0 days	3/28/16	3/29/16	3/28/16	3/29/16

Free slack and total slack (float) were discussed in Section 7.1.1. All activities with a total slack value of zero (0) in Table 41 are along the Control Phase’s critical path, which is denoted by red boxes and arrows in Figure 65. These critical tasks must be completed by the specified deadline, or the Control Phase will be delayed. Table 41 illustrates that the first part of the Control Phase’s critical path starts on 2/29/16 and ends on 3/29/16. Thus, the critical path of the Control Phase is 29 days. However, this duration is subject to change in the future, depending on the results of the Improve Phase.

Gantt charts were discussed in Section 7.1.1. A Gantt chart of the Control Phase’s planned activities was constructed and is depicted in Figure 66.

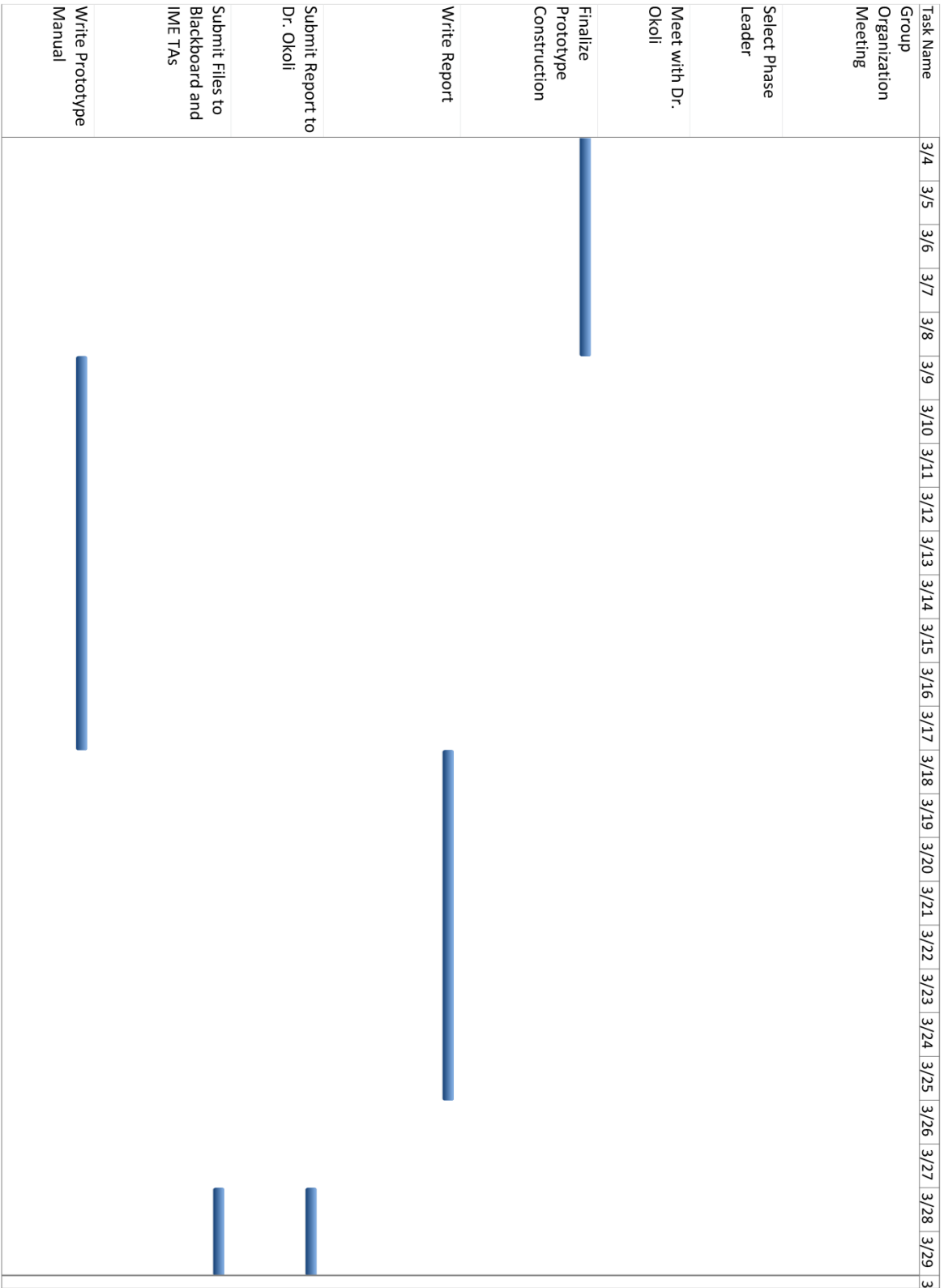

Figure 66: Gantt Chart for the Control Phase

Using Figure 65 and Figure 66, the earliest the Control Phase can end is 3/29/16. The latest the Control Phase can end is also 3/29/16. However, these planned tasks are subject to change at the conclusion of the Improve Phase, when the beginning of the Control Phase will be planned further. While the Control Phase cannot be completed any later than 3/29/16, it is possible that the phase might be completed earlier than that date when more tasks are scheduled.

## 7.2 Risk Management

To help identify risks for this project, a Strengths/Weaknesses/Threats/Opportunities (SWOT) matrix was constructed and is depicted in Figure 67. The information in this section is subject to change in future phases, depending upon how the prototype is assembled.



Figure 67: SWOT Matrix



In Figure 67, safety has been taken into consideration and the use of the machine will allow workers to harvest fruit bunches without ascending and descending each oil palm tree. Additionally, the team considered that workers might be inexperienced controlling sophisticated electronic equipment. The team solved this issue by utilizing a simple joystick controller. Finally, aluminum was used to reduce weight and add strength to the design, which makes it very durable.

Although the team has integrated electromechanical components into the prototype, the system is not completely autonomous. The system has to be setup on each tree. Subsequently, the cutting mechanism has to be pushed upward. As a result, the mechanism is not expected to work faster than a human climbing the tree. Since there are no oil palm trees located in the Tallahassee area, the device will have to be tested on a structure similar to a 40-foot tall oil palm tree, such as a light pole.

As humans become fatigued after climbing several trees throughout the day, they gradually become less productive. The prototype, however, will continue to operate at the same level of productivity, ultimately increasing the total oil palm fruit output.

As a potential threat, there exists a possibility that the cutting mechanism could harm the operator if it falls. Exceeding the budget is another potential threat, because the project would not be able to be completed within the sponsor's requirements. In addition, if receipt of the ordered parts is delayed, it could prevent an effective prototype from being completed.

The projected demand increase for palm oil [5] means that new techniques to improve the efficiency of current harvesting methods are needed. Since humans become fatigued after climbing several trees throughout the day [2], there is a limit to a human workers efficiency. An

electromechanical harvesting device would allow workers to remain on the ground and decrease the amount of physical labor during the harvesting process. This will allow laborers to harvest more oil palm fruit in a safer and more efficient manner.

The petiole, depicted in Figure 68 [36], can become a potential threat for the device during the harvesting process. Petioles are sharp and can prevent the device from descending the tree or can possibly damage it. Exceeding the budget is another potential threat, because the project would not be completed within the sponsor's requirements. Since the final design has yet been selected, it is difficult to determine how much (if any) damage may occur when operating prototype. The operator, machine, or tree could be at risk while cutting oil palm fruit. The probability and impact of each of these risks is depicted in Figure 69. In Figure 69, the color green indicates that a "low risk" is deemed acceptable and safe, while the color yellow means that a "moderate risk" is acceptable with proper safety precautions. The colors red and dark red both indicate that the "high risk" or "extreme risk" is dangerous and unacceptable, respectively. The difference between a "high risk" and "extreme risk" is that an "extreme risk" is more likely to occur than a "high risk." These descriptions are also given in Figure 69.

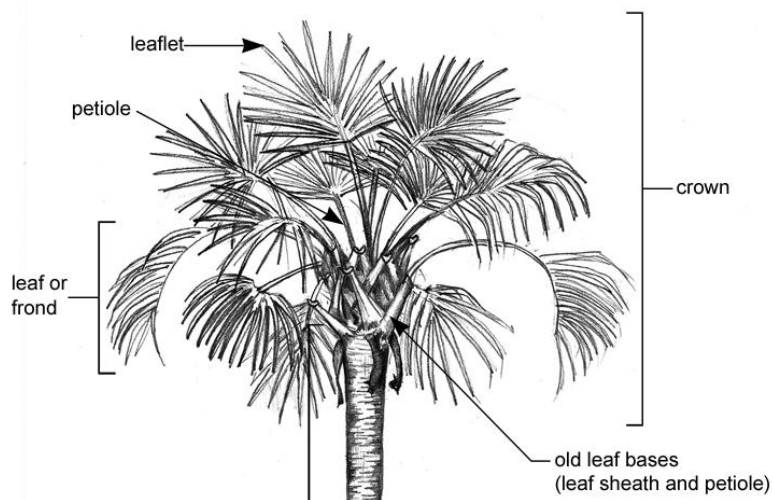

Figure 68: Upper Portion of a Generic Palm Tree [36]

		Impact		
		Low	Moderate	High
Probability	Low		Damaging the environment while operating the palm harvester	Exceeding the \$2,500 budget
	Moderate			Cutting oil palm fruit could damage the operator, machine, or tree
	High			Trees have petioles that make descending difficult

Color	Meaning	Result
	Low Risk	Acceptable/safe
	Moderate Risk	Acceptable with proper safety precautions
	High Risk	Unacceptable/dangerous
	Extreme Risk	

Figure 69: Risk Matrix

### 7.3 Budget and Bill of Materials

The sponsor has set a budget of \$2,500 for the entire project. Since any design selected will most likely contain several mechanical components and some electrical components, the mechanical parts and materials used in construction of the prototype will likely utilize most of the budget. In order to ensure the project does not exceed its budget, 8% of the budget (\$200) is set as the management reserve amount.

#### 7.3.1 Estimated Budget

The “most likely” cost of this project assumes that most parts used in the prototype will be constructed from lightweight aluminum that can easily be machined by team members. Some additional mechanical parts, such as actuators, may also be required. Since most of the electrical components will simply involve the mechanical devices communicating among themselves and

to the operator, the cost is not expected to be as significant. Based on the Class of 2015's expenditures [9] the most likely cost of this project is described in Table 42.

**Table 42: Budget Based on the Most Likely Cost of the Components**

<b>Item</b>	<b>Most Likely Cost</b>
Mechanical Components	\$500.00
Materials	\$1,500.00
Electrical Components	\$300.00
<b>Total Cost</b>	<b>\$2,300.00</b>
<b>Remaining Management Reserve</b>	<b>\$200.00</b>

Table 42 illustrates that the project would be completed within the most likely cost budget, with the entire management reserve still available. Table 43 shows a more optimistic scenario that assumes that a minimum number of mechanical and electrical parts will be required and that most of the mechanical parts can be fabricated from existing stock material.

**Table 43: Budget Based on the Optimistic Cost of the Components**

<b>Item</b>	<b>Optimistic Cost</b>
Mechanical Components	\$200.00
Materials	\$1,200.00
Electrical Components	\$100.00
<b>Total</b>	<b>\$1,500.00</b>
<b>Remaining Management Reserve</b>	<b>\$200.00</b>
<b>Budget Surplus</b>	<b>\$800.00</b>

Table 43 demonstrates that the optimistic cost budget would result in the project being completed with the entire management reserve still available, as well as a budget surplus of \$800. However, a more pessimistic scenario would likely involve some combination of the budgets given in Table 42, Table 43, and Table 43.

This scenario could result from the team members improperly machining parts, which would result in new materials that would need to be ordered and fabricated quickly, in order to not delay the project. The pessimistic cost budget is given in Table 44.

**Table 44: Budget Based on the Pessimistic Cost of the Components**

<b>Item</b>	<b>Cost</b>
Mechanical Components	\$600.00
Materials	\$1,700.00
Electrical Components	\$300.00
<b>Total</b>	<b>\$2,600.00</b>
<b>Remaining Management Reserve</b>	<b>-\$100.00</b>

Table 44 illustrates the most pessimistic scenario, the entire management reserve would be used, and the project would still exceed the budget by \$100. The team would either have to petition the sponsor for a slight increase in the budget to complete the project or fund the overage using donations from team members.

In order to determine the most plausible budget, a weighted average of the budgets given in

Table 42, Table 43, and Table 44 must be computed, using the formula  $C_e =$

$(C_o + 4C_m + C_p)/6$ , where  $C_o$  represents the optimistic budget given in Table 43,  $C_m$

represents the most likely budget given in Table 42, and  $C_p$  represents the pessimistic budget

given in Table 44. This calculation yielded the final budget given in Table 45.

**Table 45: Final Budget Based on a Weighted Average of Three Budgets**

<b>Item</b>	<b>Cost</b>
Mechanical Components	\$466.67
Materials	\$1,483.33
Electrical Components	\$267.67
<b>Total</b>	<b>\$2,217.67</b>
<b>Remaining Management Reserve</b>	<b>\$200.00</b>
<b>Budget Surplus</b>	<b>\$82.33</b>

Table 45 demonstrates that the project would be completed within the budget and results in a budget surplus of \$82.33. The previously estimated budget tables are given in Appendix B.

### ***7.3.2 Actual Expenditures and Bill of Materials***

The actual expenditures for the selected design and the bill of materials are given in Table 46.

**Table 46: Budget and Bill of Materials**

<b>Part</b>	<b>Quantity</b>	<b>Unit Price</b>	<b>Total</b>
0.375" x 96" x 38" Aluminum Sheet	1	\$529.20	\$529.20
2.2 pounds of 3D Printing Material	3	\$34.00	\$102.00
DC Motors	3	\$34.00	\$102.00
Stepper Motor	1	\$199.78	\$199.78
Track Wheel	1	\$1.96*	\$1.96*
Lead Screw Rod	1	\$7.68*	\$7.68*
Lead Screw Nut	1	\$0.50*	\$0.50*
Linear Bearings (1/4" x 13/16" x 5/16")	4	\$5.49*	\$21.96*
Shaft (1/4" x 2 ft)	1	\$2.80*	\$2.80*
Robot Mount	1	Used from Aluminum Sheet/PLA material	
12V Winch Battery	1	**	**
Connectors (25 Pack)	1	\$14.83	\$14.83
Arduino	3	\$20.79	\$62.37
Joystick Shield	1	\$8.00	\$8.00
10A 5-25V Dual Channel DC Motor Driver	2	\$23.49	\$46.98
30A 5-30V Single Brushed DC Motor Driver	1	\$37.99	\$37.99
L298N MotoMama H-Bridge Motor Driver Shield	1	\$9.98	\$9.98
Transmitter/Receiver	1	\$3.00	\$3.00
Bread Board	1	\$4.54	\$4.54
Battery Holder	3	\$1.76	\$5.28
AA Cell Batteries (4 Pack)	3	\$5.28	\$15.84
4400mAH 3.7V Li-Ion Battery	10	\$20.00	\$199.99
D Cell Batteries (8 Pack)	1	\$11.34	\$11.34
USB Breakaway Cable	1	\$5.39	\$5.39
65x22 Gauge Assorted Jumper Wires	1	\$3.95	\$3.95
25' #22 Gauge Black Hook-Up Wire	1	\$2.25	\$2.25
Miscellaneous Hardware (screws, nuts, et cetera)	As Required	\$50.00	\$50.00
Winch	1	\$104.26*	\$104.26*
Cart	1	\$269.99*	\$269.99*
Pulley	1	**	**
Braided Steel Line	1	**	**
Telescoping Square Tubing	1	**	**
Chainsaw Blade	1	**	**
* Unordered parts		Unordered Total	\$409.15
** Used from previous year		Ordered Total	\$1,405.07
		<b>TOTAL</b>	<b>\$1,814.22</b>

The analysis of the budget determines that the electrical components total to \$733.51 and the mechanical components total to \$1,080.71, with a total budget use of \$1,814.22. This leaves \$685.78 remaining from the total budget of \$2,500.00. Since the telescoping tubing from the previous year is used in the current design, it resulted in a saving of about \$650.00 in the total budget. With these savings and the large portion of the mechanical materials already in the group's possession, the budget could be used to order the electrical components and remaining mechanical components necessary to complete the design.

In order to keep the costs to a minimum and to be economical with the budget, it was decided to use parts from the Class of 2015's project that also appear in the current design. This included the 12V winch battery, the telescoping aluminum tubing, the winch, the pulleys, and the braided steel line. In total this saved the group about \$650.00 [9]. With these parts already available for use, the budget was able to be spent in other areas of the design.

Another major change to the budget with the current design from the last design is the inclusion of the utility cart. This change used \$269.99 of the budget, but replaced the bicycle wheels, the axle, and the handles from the last design, all of which totaled about \$300.00. Along with this choice being more efficient in terms of time for production and guaranteed functionality, it also is a more cost efficient choice.

Figure 70 depicts an S-curve that shows the target expenditures of the budget over the entire length of the project. Most expenditures will occur midway through the project due to the process of ordering parts. Additional expenditures that occur after the initial parts are ordered will be for tools and extra materials.



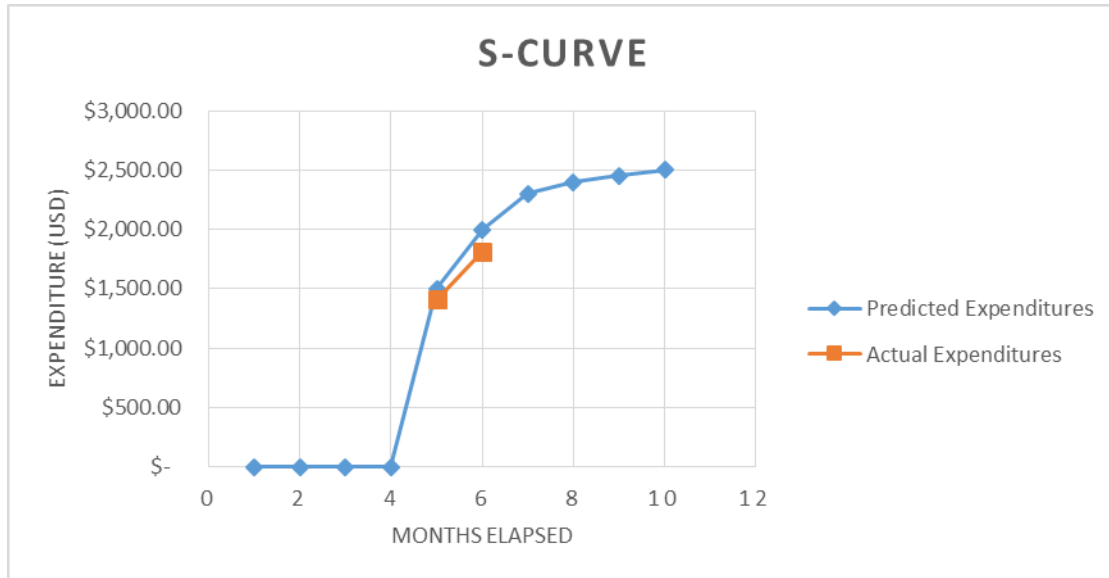

**Figure 70: S-Curve**

## 8. Conclusion

There is a large demand for palm oil, all over the world; unfortunately, the current methods used to harvest oil palm fruit are inefficient [2]. Developing a device to improve the efficiency of oil palm fruit harvesting would increase production and improve workers' safety. The current method requires humans to climb 40-foot tall palm trees and manually cut fruit bunches; this is extremely dangerous because a worker has a high probability of falling off the tree [10]. Creating an electromechanical system would eliminate this risky human involvement. To design such a device, the team met with Dr. Okoli, the project's sponsor, researched basic information on oil palm fruit harvesting methods, proposed several design concepts, and became familiar with the limitations that the final design must satisfy.

In the Define Phase, the group constructed a house of quality to determine which technical requirements were the most important to satisfy the customer's requirements; the group found that the electromechanical components was the most important technical requirement,

followed by the system weight and modular design. The group also discussed two main approaches to designing a harvesting device. The first approach involved improving one of the previous groups' designs, while the second was to create a new system. The team proposed three distinct design concepts to the project's sponsor that could achieve all customer requirements. The first design proposed making the Class of 2015's existing telescopic poles more portable and improving the cart design's mobility and safety. The second design involved modifying an existing gas-powered pole pruner with an extendable fiberglass shaft to reach a height of 40 feet. This also included mounting a camera at the end of the saw to allow the operator to see the oil palm fruit bunches at the top of the tree; this camera will be connected via Bluetooth to a screen used by a worker on the ground. The final design proposed constructing a semi-autonomous, tree-climbing robot. The robot would have ascended and descended the tree autonomously, but the user would have been required to instruct the robot to begin climbing and manually stop the robot at the top of the tree. Once the robot arrived at the top of the tree, the user would have manually operated the cutting mechanism to harvest the desired oil palm fruit bunches.

In this phase, the previously discussed concepts lead to a selected design containing aspects of all aforementioned designs. The design consists of a large circular track that encircles the palm tree and allows a cutting mechanism to traverse around its circumference. The track is raised to the fruit by using a series of pole sections that are attached together at the base and raised upward. Finite element analyses were then conducted on the components of the design to determine if it could achieve design requirements. The ring was analyzed and it was found that the stresses exhibited from the weight of the cutter and the ring itself required the thickness to be increased from 0.25 inch to 0.375 inch to produce an acceptable factor of safety of 2.8. The ring's deflection was also analyzed and found to be fewer than 1.2 inches below the horizontal. It

was determined that this still allowed the cutter to operate effectively. Next, the cutter mechanism was discussed and a design for the electrical controls was proposed. Finally, the most vulnerable component of the base, the locking mechanism, was analyzed and it was found that even with a thick and heavy pole weighing 90 pounds, the lowest possible factor of safety was 3.8.

The group then used finite element analyses to measure the effects of daily use on the proposed design. After making some modifications, such as increasing the thickness of the ring, the stresses experienced by the structure yielded acceptable factors of safety and the deflections experienced by the ring and the pole did not inhibit the overall performance of the mechanism. Next, a budget was devised based on what the team determined would be the necessary components to meet all the sponsor's design requirements. By prioritizing building the top of the design first, the ring and cutter section will likely consume the time available for the completion of this project. In the Measure Phase, the FEA of the pole was completed.

During the Analyze Phase, several milestones were achieved to help accomplish the team's end goal of completing the project by the end of the semester. After the FEA of the aluminum poling was completed, two major conclusions were apparent. First, the initial cross-sectional area of the poling was too small to support the column stress and weight of the ring, due to the density of the ring's material; aluminum was selected for the ring due to budgetary constraints, which resulted in the poling needing to be stronger and have a larger cross-sectional area to provide the required support. This revelation brought the team to their second conclusion—a design change was needed. The team's design needed to be changed because the weight of the entire system would have been too heavy for one individual to lift, which was the initial design implementation. The team then referenced the Class of 2015's design to see if any

design concepts or parts could be salvaged to foment the required design modifications. The team discovered that the lifting mechanism from the previous design would be sufficient for the new design's requirements. The square hollow aluminum poling, pulleys, braided steel cable, winch, and battery are all able to be used, which allowed the team to allocate more funds for other parts. After a new modified final design was constructed in modeling software and a bill of materials was completed, all required parts were ordered. Currently, the team is waiting for the ordered parts to arrive during the Improve Phase. During the next phase, the team will begin assembling the prototype using all available parts, so that the device can be completed by the end of the semester.

## 9. References

- [1] Soyatech, "Palm Oil Facts," 2015. [Online]. Available: [http://www.soyatech.com/Palm\\_Oil\\_Facts.htm](http://www.soyatech.com/Palm_Oil_Facts.htm). [Accessed 6 October 2015].
- [2] K. Jusoff and M. F. Zainuddin, "Musculoskeletal Disorders in Oil Palm Fruit Bunches in Malaysia," *Journal of Environmental Science & Engineering*, vol. 3, no. 7, p. 64–67, 2009.
- [3] L. Gooch, "Malaysia Enacts Minimum Wage: The New York Times," 1 May 2012. [Online]. Available: <http://www.nytimes.com/2012/05/02/business/global/malaysia-enacts-minimum-wage.html>. [Accessed 12 October 2015].
- [4] International Labour Organisation, Sectoral Activities Programme, International Labour Organisation, Committee on Work on Plantations, Recent Developments in the Plantations Sector, Geneva: International Labor Office, 1994.
- [5] E. B. Skinner, "Bloomberg," 18 July 2013. [Online]. Available: <http://www.bloomberg.com/bw/articles/2013-07-18/indonesias-palm-oil-industry-rife-with-human-rights-abuses>. [Accessed 6 October 2015].
- [6] B. Carpenter, C. X. Smith, J. A. Rojas, W. Craig, O. Abakporo and S. Trayner, "Define Phase Report for IE Senior Design Class," FAMU-FSU College of Engineering, Tallahassee, 2011.
- [7] FAMU-FSU College of Engineering, Department of Mechanical Engineering, "Projects of Previous Classes," 2015. [Online]. Available: [http://eng.fsu.edu/me/senior\\_design/](http://eng.fsu.edu/me/senior_design/). [Accessed 22 November 2015].
- [8] R. Aleman, Y. Liu, B. Newman, G. Alessandria, B. Lobo, L.-O. Verret and D. Boswell, "Measure Phase Report - Oil Palm Harvester with Telescoping Pole," FAMU-FSU College of Engineering, Tallahassee, 2013.
- [9] A. Smith, C. Chiros, M. Derius, T. Levin, T. Baker and S. Gates, "Control Phase – Palm Harvester Project," FAMU-FSU College of Engineering, Tallahassee, 2015.
- [10] World Wide Fund for Nature, "Creating Ripples for Positive Change," 10 February 2014. [Online]. Available: <http://www.worldwildlife.org/stories/creating-ripples-for-positive-change>. [Accessed 6 October 2015].
- [11] SayNotoPalmOil.com, "Palm Oil," 2015. [Online]. Available:

- [http://www.saynotopalmoil.com/Whats\\_the\\_issue.php](http://www.saynotopalmoil.com/Whats_the_issue.php). [Accessed 6 October 2015].
- [12] CommodityBasis, "Palm Oil Prices," 2014. [Online]. Available: [https://www.commoditybasis.com/palmoil\\_prices](https://www.commoditybasis.com/palmoil_prices). [Accessed 6 October 2015].
- [13] R. Aleman, G. Alessandra, D. Boswell, Y. Liu, B. Lobo, B. Newan and L.-O. Verrer, "Define Phase Deliverable - Oil Palm Pruning Device," FAMU-FSU College of Engineering, Tallahassee, 2013.
- [14] American Society for Quality, "Building a House of Quality with Technical and Competitive Benchmarking," 2004. [Online]. Available: <http://asq.org/learn-about-quality/benchmarking/overview/tutorial-building-house-of-quality.html>. [Accessed 14 October 2015].
- [15] IDEACore, "QFD Designer User Guide," 2006. [Online]. Available: [http://ideacore.com/index.php?option=com\\_content&view=article&id=111&Itemid=90](http://ideacore.com/index.php?option=com_content&view=article&id=111&Itemid=90). [Accessed 15 October 2015].
- [16] Y. G. Ng, M. T. S. Bahri, M. Y. I. Syah, I. Mori and Z. Hashim, "Ergonomics Observation: Harvesting Tasks at Oil Palm Plantation," *Journal of Occupational Health*, vol. 55, no. 5, p. 405–414, 2013.
- [17] B. A. Talib and Z. Darawi, "An Economic Analysis of the Malaysian Palm Oil Market," *Oil Palm Industry Economic Journal*, vol. 2, no. 1, p. 19–27, 2002.
- [18] K. East, "Global labor imbalance: Some countries see a surplus of jobs while others see higher unemployment," 7 July 2014. [Online]. Available: <http://www.washingtontimes.com/news/2014/jul/7/global-labor-imbalance-some-countries-see-a-surplu/?page=all>. [Accessed 18 October 2015].
- [19] Microsoft TechNet, "Difference between free slack and total slack," 28 June 2012. [Online]. Available: <https://social.technet.microsoft.com/Forums/projectserver/en-US/d373c2ae-11b4-4030-a4fb-62bb8a2d73a1/difference-between-free-slack-and-total-slack>. [Accessed 6 October 2015].
- [20] IDTools, "Identifying Commonly Cultivated Palms," May 2014. [Online]. Available: [http://idtools.org/id/palms/palmid/images/fs\\_images/anatomy-fan-palm.png](http://idtools.org/id/palms/palmid/images/fs_images/anatomy-fan-palm.png). [Accessed 2015 October 15].
- [21] OnlineMetals.com, "Metals and Plastic Materials," 2015. [Online]. Available: <http://www.onlinemetals.com/>. [Accessed 27 November 2015].

- [22] Robo 3D, "Products," 2015. [Online]. Available: <http://store.robo3d.com/collections/filament-pla/>. [Accessed 27 November 2015].
- [23] Lin Engineering, "Stepper Motor Manufacturer," 2015. [Online]. Available: <http://www.linengineering.com/>. [Accessed 27 November 2015].
- [24] McMaster-Carr, "General Purpose ACME Fully Threaded Rod," 2015. [Online]. Available: <http://www.mcmaster.com/#93410a111/=10101g5>. [Accessed 27 November 2015].
- [25] McMaster-Carr, "Acme Threaded Rods and Studs," 2015. [Online]. Available: <http://www.mcmaster.com/#general-purpose-acme-rods/=10101ny>. [Accessed 27 November 2015].
- [26] Adafruit Industries, "Linear Bearing Platform (Small) - 8mm Diameter - SC8UU," 2015. [Online]. Available: <http://www.adafruit.com/products/1179?gclid=CLHz-aK8pMkCFVGQHwodJwUG9A>. [Accessed 27 November 2015].
- [27] McMaster-Carr, "Shafts," 2015. [Online]. Available: <http://www.mcmaster.com/#precision-shafts/=10102dz>. [Accessed 27 November 2015].
- [28] Adafruit Industries, "Linear Rail Shaft Guide/Support - 8mm Diameter - SK8," 2015. [Online]. Available: <http://www.adafruit.com/products/1182>. [Accessed 27 November 2015].
- [29] Stihl, "Pole Pruners," 2015. [Online]. Available: <http://www.stihlusa.com/products/pole-pruners/>. [Accessed 18 October 2015].
- [30] Coolmagnetman.com, "Experiments with magnets and conductors," 2015. [Online]. Available: <http://www.coolmagnetman.com/magconda.htm>. [Accessed 23 November 2015].
- [31] Clearwater Composites, LLC, "Properties of Carbon Fiber," 2015. [Online]. Available: <http://www.clearwatercomposites.com/resources/Properties-of-carbon-fiber>. [Accessed 23 November 2015].
- [32] InvestmentMine, "1 Week Aluminum Prices and Price Charts," 2015. [Online]. Available: <http://www.infomine.com/investment/metal-prices/aluminum/1-week/>. [Accessed 23 November 2015].
- [33] US Composites, "Carbon Fiber Fabrics," 2015. [Online]. Available: <http://www.uscomposites.com/carbonpage.html>. [Accessed 23 November 2015].

- [34] A. Castle, "Know Your Arduino: A Practical Guide to The Most Common Boards," 12 June 2013. [Online]. Available: <http://www.tested.com/tech/robots/456466-know-your-arduino-guide-most-common-boards/>. [Accessed 24 November 2015].
- [35] L. George, "L293D – Quadruple Half H DC Motor Driver," 2015. [Online]. Available: <https://electrosome.com/l293d-quadruple-half-h-dc-motor-driver/>. [Accessed 24 November 2015].
- [36] P-N Junction Lab, "L293 Dual DC motor / Stepper motor controller," 2015. [Online]. Available: <http://pnjunctionlab.com/l293-d/>. [Accessed 24 November 2015].
- [37] Oriental Motor U.S.A. Corp., "Basics of Motion Control," 2015. [Online]. Available: <http://www.orientalmotor.com/technology/articles/step-motor-basics.html>. [Accessed 24 November 2015].
- [38] AmpFlow, "Small High Performance Motors," 2015. [Online]. Available: [http://www.ampflow.com/small\\_high\\_performance\\_motors.htm](http://www.ampflow.com/small_high_performance_motors.htm). [Accessed 29 November 2015].
- [39] Lin Engineering, "NEMA SIZE 23 | Step Size 1.8°," 2015. [Online]. Available: <http://www.linengineering.com/stepper-motors/E5718.aspx>. [Accessed 29 November 2015].
- [40] Terapeak, "433mhz - Wireless Uhf Receiver - Arduino & Raspberry," 2015. [Online]. Available: <http://www.terapeak.com/worth/433mhz-wireless-uhf-receiver-arduino-raspberry/281207346165/>. [Accessed 24 November 2015].
- [41] Summerfuel Robotics, "RF Wireless Transmitter & Receiver Module 433Mhz for Arduino MX-05V/XD-RF-5V," 2015. [Online]. Available: <https://sites.google.com/site/summerfuelrobots/arduino-sensor-tutorials/rf-wireless-transmitter-receiver-module-433mhz-for-arduino>. [Accessed 30 November 2015].
- [42] StackExchange, "Can I use a 6 pin Bluetooth module in a 4 pin socket?," 30 July 2015. [Online]. Available: <http://arduino.stackexchange.com/questions/13818/can-i-use-a-6-pin-bluetooth-module-in-a-4-pin-socket>. [Accessed 24 November 2015].
- [43] R. Owens, "Joystick\_Shield-v14," 29 November 2011. [Online]. Available: [http://cdn.sparkfun.com/datasheets/Dev/Arduino/Shields/Joystick\\_Shield-v14.pdf](http://cdn.sparkfun.com/datasheets/Dev/Arduino/Shields/Joystick_Shield-v14.pdf). [Accessed 24 November 2015].
- [44] Seculife, "Wireless Home Security System Baby Monitor 2.4GHz 7" LCD One 4CH DVR & One 380TVL Weatherproof Camera WRC890+WCM7061B - AU Plug," 2015. [Online].



Available: [http://www.seculife.com/details/Wireless-Home-Security-System-Baby-Monitor-2-4GHz-7-LCD-One-4CH-DVR-One-380TVL-Weatherproof-Camera-WRC890-WCM7061B-AU-Plug-84000327D/?utm\\_source=google&utm\\_medium=pla&utm\\_campaign=cse&gclid=CjwKEAiA7MWyBRDpi5TFqqmm6hMSJAD6G](http://www.seculife.com/details/Wireless-Home-Security-System-Baby-Monitor-2-4GHz-7-LCD-One-4CH-DVR-One-380TVL-Weatherproof-Camera-WRC890-WCM7061B-AU-Plug-84000327D/?utm_source=google&utm_medium=pla&utm_campaign=cse&gclid=CjwKEAiA7MWyBRDpi5TFqqmm6hMSJAD6G). [Accessed 2015 November 2015].

- [45] MatWeb, "ASTM A36 Steel, bar," [Online]. Available: <http://matweb.com/search/DataSheet.aspx?MatGUID=d1844977c5c8440cb9a3a967f8909c3a&ckck=>. [Accessed 23 November 2015].

## Appendix A: Return on Investment Calculations

Wage assumptions and return on investment calculations for Malaysian oil palm fruit harvesters.

### Assumptions

Malaysian workers earn \$297 per month.

Each oil palm plantation contains hundreds of trees.

Oil palms are harvested for eight (8) hours daily.

A worker earns a simple salary of \$297/month  $\times$  12 months = \$3,564/year

The return on investment (ROI) formula is:

$$\text{ROI} = \frac{(\text{Gain from Investment} - \text{Cost of Investment})}{\text{Cost of Investment}}$$

Computing the ROI:

$$\text{ROI} = \frac{(\$3,564 - \$2,000)}{\$2,000} = 0.7820$$

$$\text{ROI}_{\text{percent}} = \text{ROI} \times 100\% = 0.7820 \times 100\% = 78.20\%$$

## Appendix B: Estimated Budget Tables

Table 47: Estimated Budget for the Ring and Cutter Mechanism

Part	Cost (\$)	Source
Ring	1,050	[37]
3D Printing Material	100	[38]
DC Motors	150	Estimated
DC Motors	150	Estimated
Stepper Motor	130	[39]
Lead Screw Rod	27	[40]
Lead Screw Nut	12	[41]
Electrical Components	115	Estimated
Linear Bearings	30	[42]
Shaft	38	[43]
Shaft Housing	20	[44]
Robot Mount	30	[37]
Battery	150	Estimated
<b>Total</b>	<b>2,002</b>	

\*3D printing refers to additive manufacturing

The budget given in Table 47 lists the price of each part. Each entry contains the estimated cost of each respective part and the source where it was obtained. The team is using a top-to-bottom approach because of the complexity of the ring and cutter. The ring will be made out of a 96-inch by 38-inch sheet of aluminum that will cost \$1,050. Other mechanical components will be obtained from this sheet, such as the platform on which the robot stands, as well as the mount housings. \$100 will be allocated to 3D printer materials. Even though the price per 2.2 pounds of 3D printing materials is \$50, an extra set will be ordered in case of any issues during fabrication. Some electrical components and motors are yet to be chosen, because Dr. Gupta is currently advising the team on motors that will meet the design requirements. Lightweight motors that the team has found cost around \$150. All electrical components that will control the motors are not expected to cost more than \$150. The robot mount will be machined or made from a water jet from one solid block of aluminum that will cost \$30. A battery has not been selected but it is

estimated to cost \$150. As shown in Table 47, total cost of the preliminary ring design is expected to be around \$2,000. After researching material costs from a variety of different vendors, it was found that the aluminum polling and base could not be completed with only \$500 remaining in the budget. Additionally, there is a possibility that once this design is analyzed further, the initial \$2,000 estimate could increase and restrict the budget for the rest of the design further. These estimates were used to construct the bill of materials given in Table 48.

**Table 48: Bill of Materials for the Ring and Cutter Mechanism**

<b>Bill of Materials</b>	
<b>Part</b>	<b>QTY.</b>
0.375" x 96" x 38" Aluminum Sheet	1
2.2 pounds of 3D Printing Material	2
Hinge	1
DC Motors	3
Stepper Motor	1
Track Wheel	1
Lead Screw Rod	1
Lead Screw Nut	1
Linear Bearings	4
Shaft	2
Shaft Housing	4
Robot Mount	1
Battery	1
Connectors	15
Arduino	2
Joystick Shield	1
Motor Drivers	3
Transmitter/Receiver	1
Bread Board	1
Battery Holder	2
AA Cell Batteries	8
D Cell Batteries	8
USB Breakaway Cable	1
Miscellaneous Hardware (screws, nuts, et cetera)	As Required