

Design for Manufacturing

Team 6

Capacitor Assembly Automation



Members:

Marissa Foreit- mlf12b

Kyler Kazmierski- kjk12f

Folaranmi Adenola- folaranmi1.adenola

Olayinka Oladosu- olayinka1.oladosu

Faculty Advisor

Dr. Moore

Sponsor

Mr. Walker

Instructor

Dr. Shih

4/7/2017

Table of Contents

Table of Figures	iv
ACKNOWLEDGMENTS	ivii
1. Design for Manufacturing	Error! Bookmark not defined.
2. Design for Reliability	2
3. Design for Economics	3

Table of Figures

Figure 1: Exploded View of Tape Roller.....	1
Figure 2: Exploded View of Wrapping Device	2
Figure 3: Pie Chart	3
Figure 4: Budget Report.....	4
Figure 5: Pick and Place Robot.....	4

ACKNOWLEDGMENTS

We would like to thank Dr. Shih for teaching the class and providing their feedback. We would also like to thank Mr. Walker, our sponsor, for his generosity and guidance in overseeing this project. Lastly, we would like to thank Dr. Moore for advising us and sharing his knowledge and suggestions on what future steps we could take.

1. Design for Manufacturing

To assemble the tape roller, the parts needed to be machined first. The machined parts include the base plate, plate, posts, roller arms, guide rails and rods (Figure 1). The next step is to begin assembling. First, screw the posts into the base plate. The next step is to screw the guide rails onto the posts. From there, assemble the roller arms and attach them to the guide rails. The overall assemble process takes about 30 minutes and the machining process takes about two weeks. The design does not have a lot of room for reducing parts. Each part is essential to the overall function.

Both the L-Gauge and the gauge block were 3D printed due to time constraints, however these could both be machined out of aluminum. The gauge block should also be calibrated prior to use to ensure proper measurements.

The wrapping mechanism (Figure 2) had majority of the parts 3D printed as well. However, if time permits, these parts should be machined as well. The assembly has not yet begun for this device.

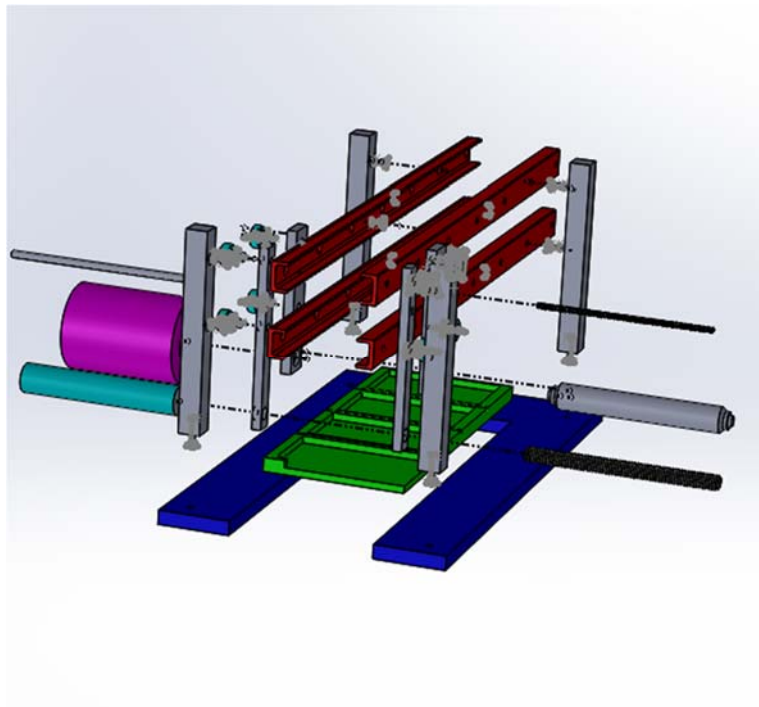

Figure 1: Exploded View of Tape Roller

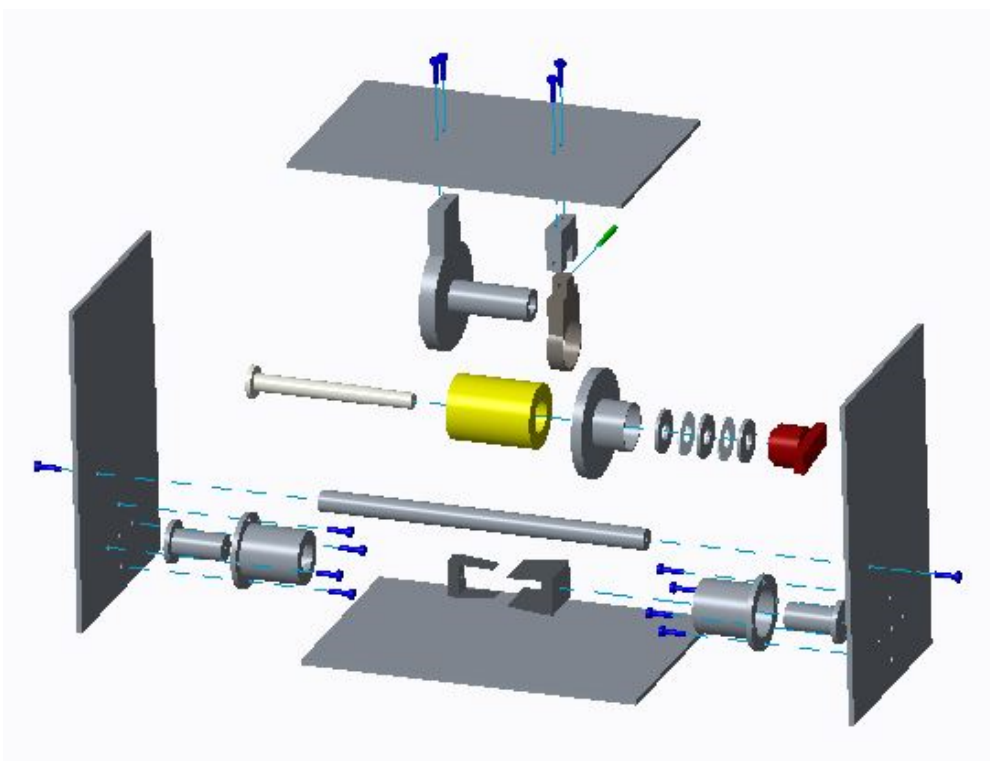

Figure 2: Exploded view of wrapping device

2. Design for Reliability

Currently, the tape roller is having a few issues with the roller arms staying on the guided rails. Once this issue is fixed, the design should be able to run for at least 1000 times. The whole prototype is made out of aluminum, so it is durable. The wheels on the roller arms way wear out over time, however they are easy to replace. The L-gauge and gauge block will be able to function at least 10,000 times. These aren't used for dynamic motions, so they won't experience as much wear and tear. However, the gauge block will need to be re-calibrated once a year to ensure it still is measuring accurately. The wrapping design is not finished yet, so the reliability study cannot be done for it yet. However, while building it, the goal is to build a reliable and safe prototype.

3. Design for Economics

The overall production costs \$520.23 (Figure 3). All of the parts were either manufactured for free or 3D printed for free. The main costs come from purchasing the raw materials. The cost would most likely increase due to the cost of manufacturing. An estimated manufacturing cost is about \$700, which would bring the overall total to about \$1,200.

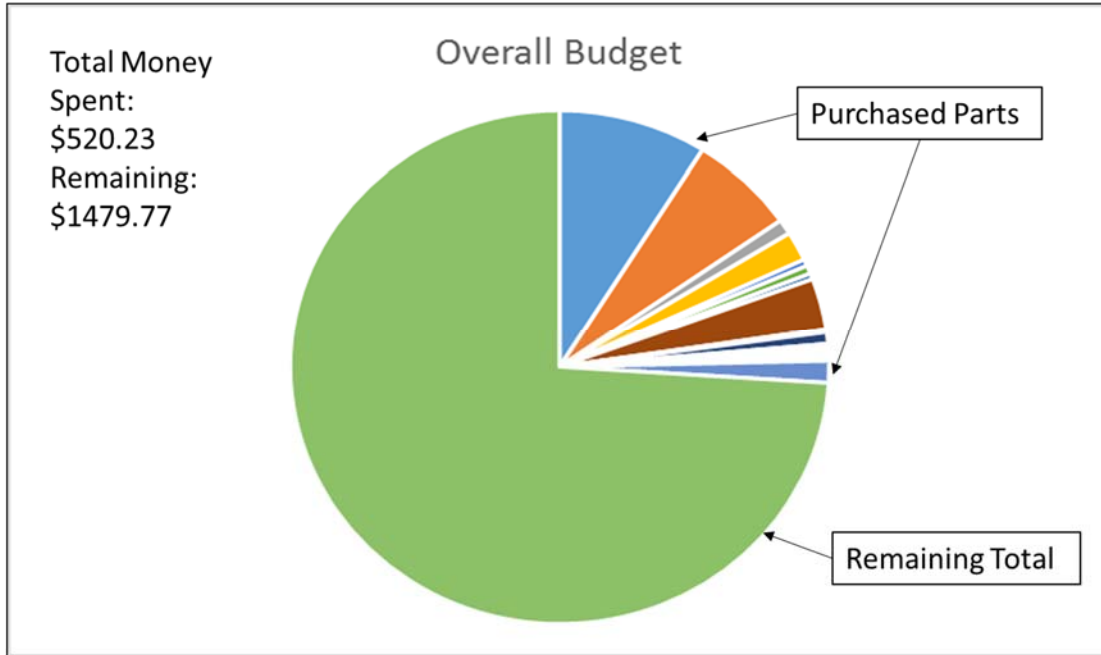

Figure 3: Budget Report Pie Chart

Team 6 Budget Report		
Part Number	Item	Cost
60135K95	Guide Rails	178
60135K94	Track Roller	127.68
9008K12	AL Bars	18.84
45K177	Tape	37.15
8975K11	AL 12" x 24" sheet	8.24
91253A266	Short Screws	10.65
91253A010	Long Screws	7.18
98023A111	Washers	64.81
8975K615	Al Bar	2.53
8974K22	Al Rod	1.54
8974K13	Al Rod	14.89
98750A113	Threaded Stud	2.4
92825A355	Spacers	3.42
91247A489	Hex Head Screw	4.89
87095K82	Stainless Steel Rod	5.15
92240A542	Hex Head Screw	5.29
8982K44	Al 90 angle	27.57
	Total	520.23
	Remaining	1479.77

Figure 4: Budget Report

The only product on the market comparable to our design would be a “pick and place” robot (Figure 5). The “pick and place” robot could be used for the stacking process, however it costs about \$2,000, whereas the L-gauge was 3D printed for free. Since this product would not save much assembly time, it was not selected to be used within the design process.



Figure 5: Pick and Place Robot