

Midterm Report 1

Team 6

Capacitor Assembly Automation



Members:

Marissa Foreit- mlf12b

Kyler Kazmierski- kjk12f

Folaranmi Adenola- folaranmi1.adenola

Olayinka Oladosu- olayinka1.oladosu

Faculty Advisor

Dr. Moore

Sponsor

Mr. Walker

Instructor

Dr. Gupta

10/21/2016

Table of Contents

Table of Figures	iii
ABSTRACT	iv
ACKNOWLEDGMENTS	v
1. Introduction	1
2. Project Description	1
2.1 Needs Statement.....	1
2.2 Background Research	2
2.3 Goal Statement.....	2
2.4 Objectives.....	2
2.5 Constraints and Costumer Requirements	2
3. HOQ	3
4. Concept Generation	4
5. Design and Analysis	7
5.1 Automation Design 1.....	7
5.2 Dimensional Check 1.....	7
5.3 Dimesnional Check 2.....	8
6. Gantt Chart and Project Planning	9
7. Conclusion	10
References	12
Biography	13

Table of Figures

Figure 1: House of Quality showing the relationship between Customer Requirements and Engineering Characteristics	4
Figure 2: Individual Capacitor section approx. 4”L x 2.5”W showing tabs used for electrical connection	5
Figure 3: Assembly of 4 sections, electrical connection tabs soldered and lead wires attached ...	5
Figure 4: Assembly wrapped with insulation material	6
Figure 5: Gauge block with cut-out of the capacitor dimensions	7
Figure 6: Capacitor sliding into gauge block	8
Figure 7: Gauge block without capacitor	8
Figure 8: Dimension check process for 2 nd gauge block design	9
Figure 9: Gantt Chart	10

ABSTRACT

Capacitor assembling involves a series of steps and processes; this consequently makes the assembly process labor intensive and time consuming. The objective of this project, sponsored by Unison Industries - GE Aviation, is to develop a level of automation for the assembly process of capacitors by designing and fabricating a working prototype of equipment that can reduce the assembly time by 50%. This prototype must also be able to perform a dimensional check of the capacitor immediately after assembly. To accomplish this goal, Team 6 has been in contact with Kevin Walker of Unison Industries. He will be providing the team with the information needed in order to develop design solutions.

ACKNOWLEDGMENTS

Team 6 would like to thank Unison Industries for being our sponsor for this project. We would also like to thank Kevin Walker for taking the time to be our mentor throughout this upcoming process.

1. Introduction

Unison Industries is a subsidiary of GE, specializing in electrical components for jet engines, ignition systems, generators and sensors. They are the global leader for supplying products such as complex gas turbine engine components and electrical/mechanical systems. 80% of jet engines worldwide are installed with ignition systems produced by Unison Industries.

The main objective of this project is to develop an automated process to assemble the capacitors. The current process is very labor intensive and requires various steps, which slows down the production of these products. The steps include placing tape on each section of the capacitors, stacking the capacitors, soldering electrical tabs, wrapping the stacked capacitors, taping the entire package and doing a dimensional check. Another portion of this project is dedicated to creating a process to do a final dimensional check on all three dimensions at once, instead of measuring each dimension one at a time. This will also speed up the assembly time for this part.

2. Project Definition

2.1 Needs Statement

The project requires an automated system to be developed in order to assemble the capacitors.

The capacitors consist of the following parts:

- 4 individual capacitor sections that become stacked together
- a layer of tape and insulator paper between each section
- electrical tabs for connections
- lead wires
- insulation material wrapped around the assembly

The finished assembly production line needs to reduce the time and labor that is required to assemble the capacitor. By the end of this project, a working prototype of the automation process needs to be created, as well as a method to quickly do a dimensional analysis of the finished assembly.

2.2 Background Research

Capacitors are used to store energy as an electrostatic field [1]. There are 4 conducting plates with insulated paper in between each layer. Capacitors for jet engines are capable of storing anywhere from 30 to 300 times the energy stored in a car spark capacitor.

There are several different types of capacitor assembling machines, generally categorized by capacitor type. There are also options for slow, medium or high-speed assembly lines. For this project, the goal will be to design either a medium or a high-speed assembly line. There is also the option of developing an automatic system versus a semi-automatic system. The automatic system does not require the use of an operator and is fully functional on its own. The semi-automatic system requires the slight use of an operator [1]. After discussing it with the sponsor, Team 6 will develop a semi-automated system. Steps to design this system will be discussed in further detail later on in the paper.

2.3 Goal Statement

Design and develop an automated process in order to improve the manufacturing and assembly of the ignition exciter.

2.4 Objectives

- Improve the assembly time of the ignition exciter through some level of automation
- Maintain or increase the reliability of the ignition exciters
- Create a more economical and efficient manufacturing process
- Design and develop working prototype machinery to most efficiently manufacture the ignition exciters
- Test the prototype(s) and make any necessary modifications that may improve the manufacturing process

2.5 Constraints and Customer Requirements

- Machinery built must be both practical and economical
- The process and machinery created must comply with any applicable safety regulations
- Process must include some level of automation in the assembly steps

- Projects needs to reduce overall assembly time from 27 min to 15 min
- Project must be completed by the end of the Spring 2017 semester

3. House of Quality

The objective of Team 6 is to lower the production time of the assembly of capacitors from 27 minutes to 15 minutes through the aid of an automation process, which eradicates the labor-intensive manual process of assembly.

The House of Quality (Figure 1) was created in order to know what aspects are desired so that the team can lead focus on that aspect. The House of Quality below indicates customer's requirements and technical requirements. House of Quality aids in determining the important factors necessary to fulfill the need statement and constraints. It displays the rank and necessity of each requirement. This will serve as an aid to assess priorities prior to the assembly of the capacitors. The technical requirements are shown with their corresponding customer requirements.

As a whole, the house of quality (HOQ) shows that the primary Engineering requirements are Production time (our priority in this project), the reliability, dimensions. Having this in mind, it is germane to remember that although a large portion of the project time must be spent pursuing these goals, the others will not be neglected. Those three characteristics were ranked most highly because of their direct effect upon how much time it will save during assembly of this capacitors, reliability, and ensuring that we stay within the specified dimension range (4.25”H x 2.6”L x 1.38”W). The HOQ displays that some Engineering characteristics can be addressed with less urgency than other characteristics. This is evident in the conceptual designs displayed by Team 6 in this report. The designs focuses mainly on the three earlier stated technical requirements because we have to start with a technically sound design that addresses key requirements, which are paramount to the success of this project

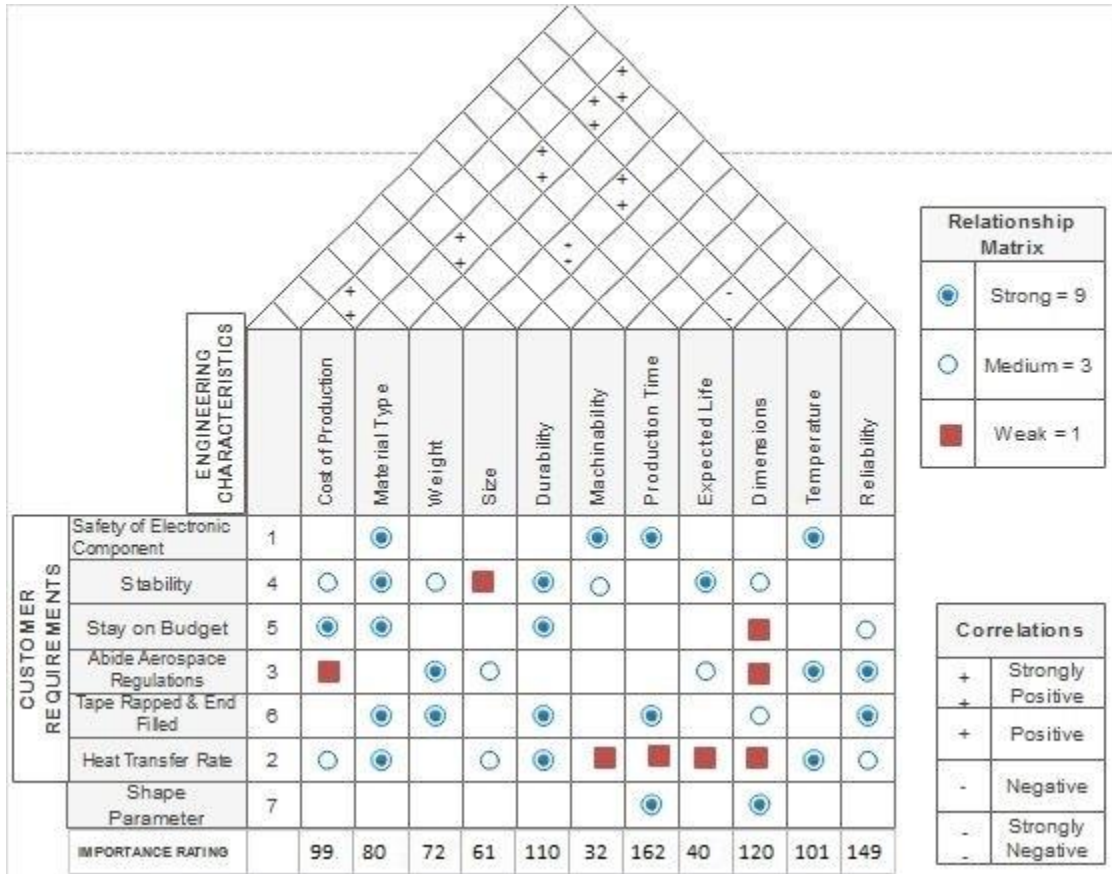

Figure 1. House of Quality showing the relationship between Customer Requirements and Engineering Characteristics

4. Concept Generation

To design a semi-automated system, the steps for assembly need to first be analyzed. Unison Industries have provided the following assembly steps [2]:

- A. Select 4 capacitor sections and attach clipped tabs together and verify capacitance is within range. If not select different capacitors to meet capacitance range (Figure 2)

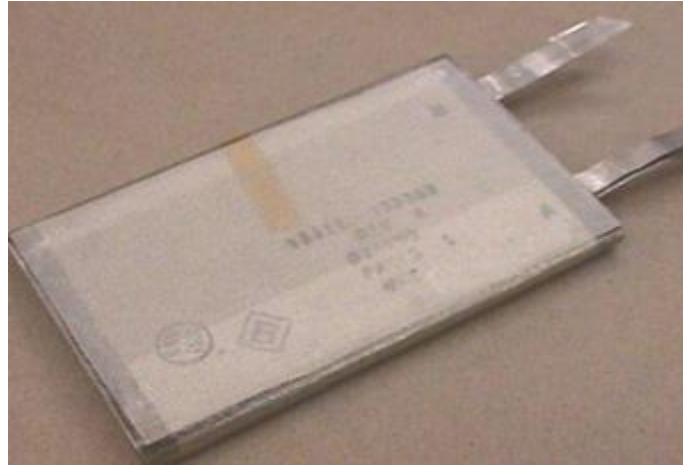

Figure 2: Individual Capacitor section approx. 4”L x 2.5”W showing tabs used for electrical connection [2]

- B. Cut a piece of tape and place between each capacitor section. The clipped tabs must line up on one side. (Do not use an Xacto knife to cut the tape)
- C. Form capacitor tabs and solder
- D. Attach and solder 8” wire to clipped tabs and 8” wire to unclipped tabs
- E. Assemble sleeving wires
- F. Assemble 2” tape over both soldered tabs (Figure 3)

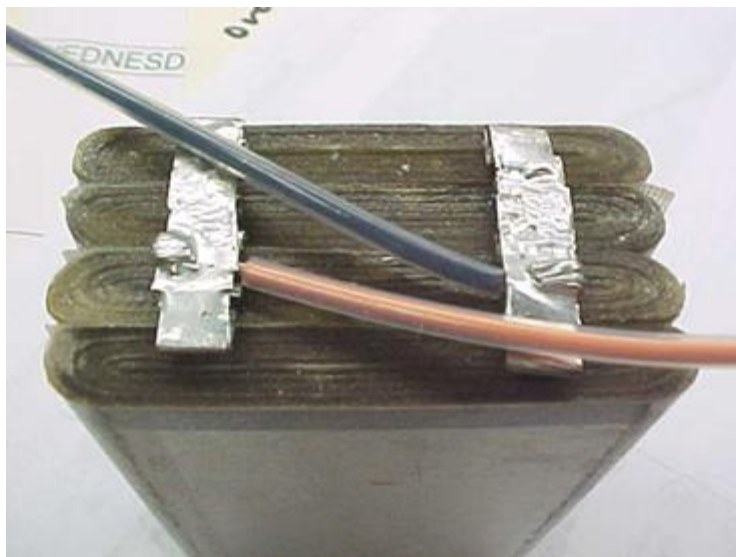

Figure 3: Assembly of 4 sections, electrical connection tabs soldered and lead wires attached [2]

- G. Form safety loop in both wires shown

- H. Wrap an 8.31” piece of insulation around sides of pack
- I. Secure insulation and wires in place using 1 ½ turns of Tape in 3 places (Figure 4)

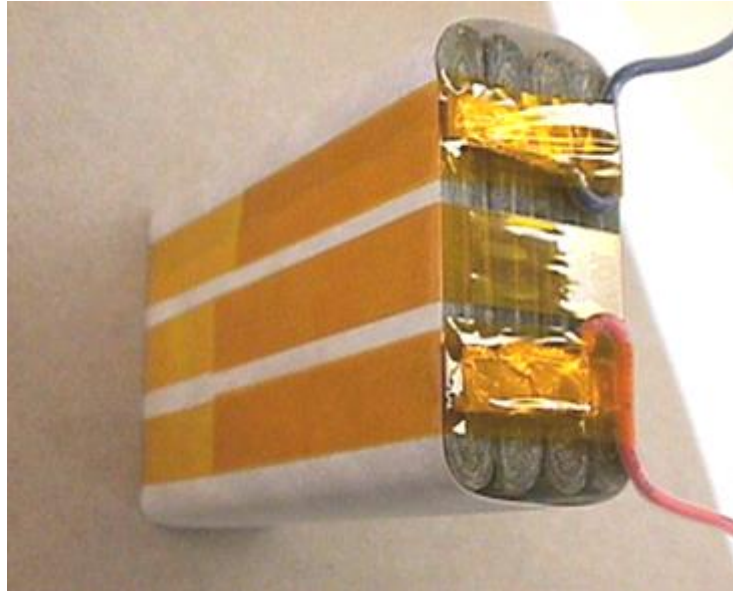

Figure 4: Assembly wrapped with insulation material [2]

- J. Final Inspection
 - a. Using Vernier's, check the following dimensions:
 - i. 4.25” max, 1.38” max, 2.60” max
 - b. Visually inspect the following:
 - i. Correct and complete assembly
 - ii. Damage to wires or assembly
 - iii. Paperwork complete

Not all of these steps need to be automated because they are simple steps, or developing an automated process would be too difficult. For example, the stacking of the capacitors is a simple and quick step that could remain as a manual process.

5. Design and Analysis

5.1 Automation Design 1

The steps that will become automated in this design are steps B, H and I. For step B, a rolling mechanism could be designed to roll the tape over the top of 3 capacitors. The operator would then have to cut the tape in between the capacitors with a scissor since a Xacto knife is not allowed to be used. This would save time because the current process requires the operator to unwrap each piece of double-sided tape, and place it on 3 of the capacitors, one at a time. This new mechanism would pull the tape off a roll, and it would cover all three pieces at once. However, the stacking of the capacitors sections would still be manual but a device will be created to ensure better quality when stacking them.

Steps H and I are both time consuming due to the difficulty of tightly wrapping the paper around the capacitor pack. A system is to be designed so that the paper can be wrapped tightly and quickly, followed by a system to wrap 3 pieces of tape around the whole thing to ensure the paper remains tight.

5.2 Dimensional Check 1

One requirement of the project is to develop a way to check all three dimensions at once. To do this, a functional gauge has been created (Figure 5).

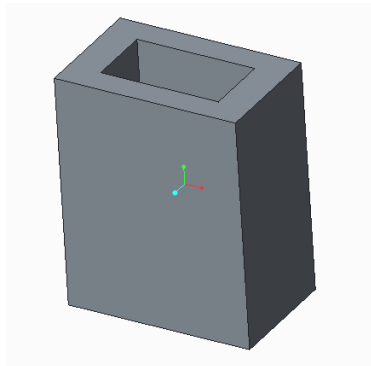

Figure 5: Gauge block with cutout of the capacitor dimensions

The way the gauge works is that it has a cut-out of the maximum allowed dimensions of the finished part, which are 4.25" x 1.38" x 2.60" (Figure 6). If the part is able to slide into the gauge, it passes the dimension check. If the part does not slide into the gauge, the part is too large and therefore it fails.

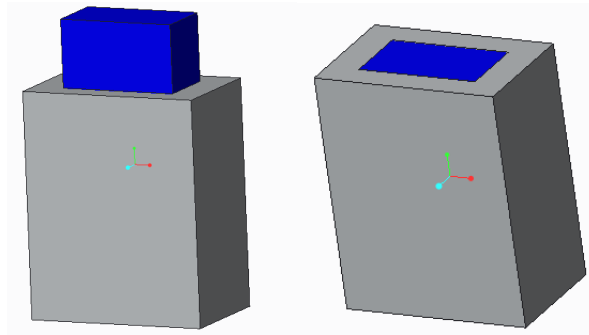

Figure 6: Capacitor sliding into gauge block

By creating this gauge, the overall process will speed up. The current method is to check each dimension one at a time using a caliper, which can be time consuming. This design is functional, easy to machine, and will make the dimension check more efficient.

5.3 Dimensional Check 2

An alternate gauge design was also created to compare with the first design. The second gauge design aimed to have more access to the capacitor assembly when checking the dimensions and is shown below (Figure 7).

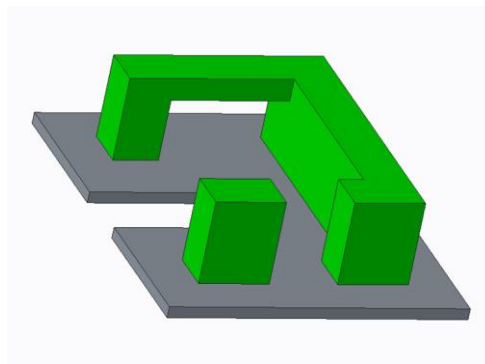

Figure 7: Gauge block without capacitor

This gauge works by laying the finished assembly on the side with the largest surface area and sliding it into the front gateway of the design which is 4.25" wide and pushing it to the back of the gauge. The capacitor is then pushed through the top doorway in order to check its height and width, which are supposed to be 1.38" and 2.60" respectively. This process is illustrated in the pictures below (Figure 8).

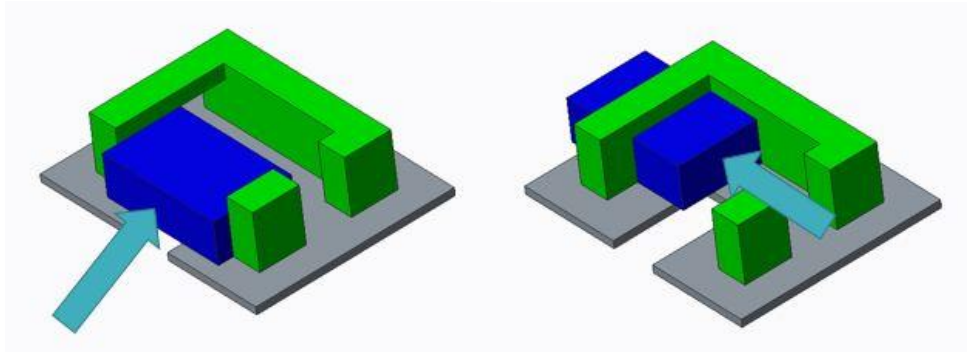

Figure 8: Dimension check process for 2nd gauge block design

This design was created with the intention of improving the speed of the dimension check by using a quicker and more efficient process. With this design, the assembly does not have to be pushed out unless it is the wrong dimensions. If the assembly gets stuck in the gauge, the cutout on the bottom should aid in quickly removing the part. Otherwise, the assembly is pushed in two directions with the latter removing it from the gauge. The base was designed to be flat and wide so that it can be bolted down onto a table for added stability, but the part is also small enough (8.25" x 6.60") to be easily transported around the shop.

6. Gantt Chart and Project Planning

A Gantt Chart (Figure 9) was created to lay out the different tasks needed to complete this design project and the amount of time each task will take. The chart only extends to the end of this semester, and will be re-evaluated in December once there is a better idea of how far along the team is. The team is currently working on concept design and hopes to have a few different prototype ideas within the next few weeks.

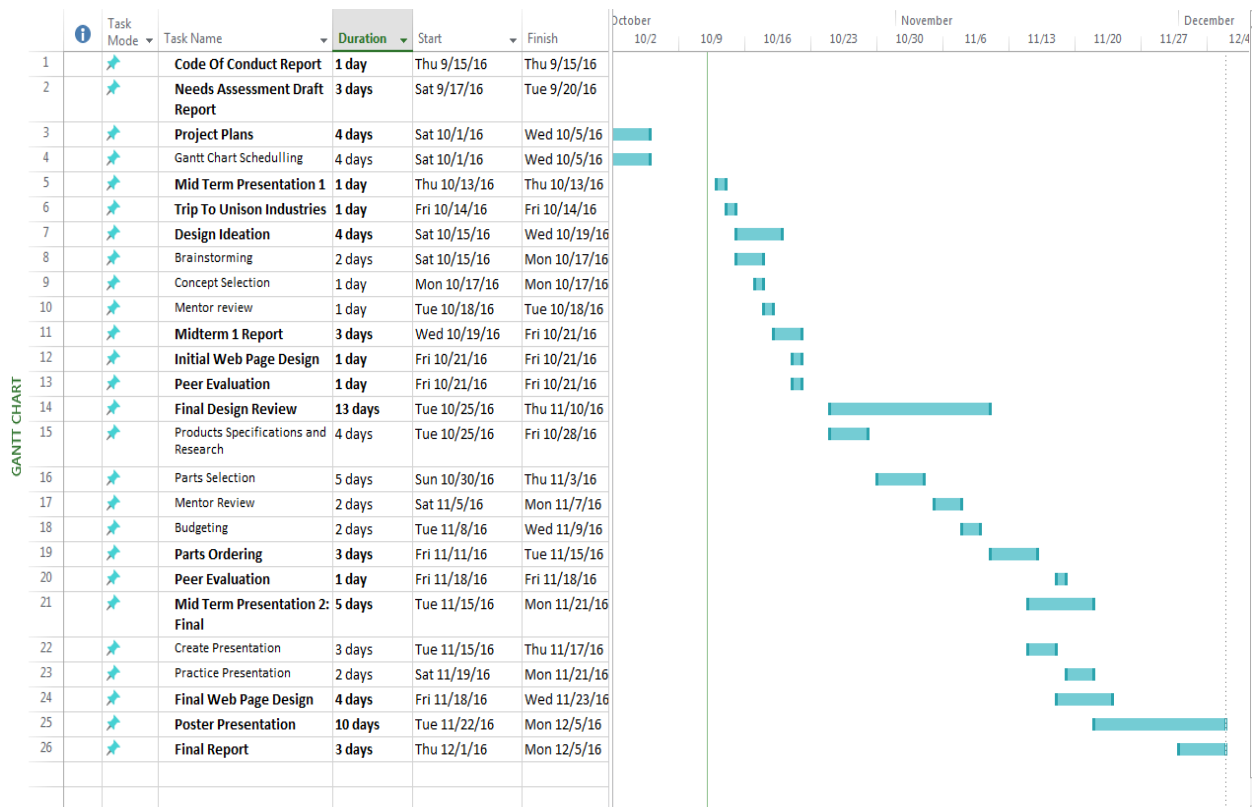

Figure 9: Gantt Chart

The main timeline goals of the group are to have a finalized design selected in December and at least one backup design in case the original does not work. Since nothing works on the first try, Team 6 would like to order the material in December and start building the prototype in early January. This will allow plenty of time for mistakes and errors. The team will be able to brainstorm and redesign the prototype, if needed, before the final deadline in April. Since the process Team 6 is automating has so many different steps, not all of them need to be automated. This gives the team the freedom to decide to keep certain steps a manual process if the automation designs fails or becomes too complicated.

7. Conclusion

The purpose of this project is to develop an automated system that will make the assembling of capacitors of faster and more economical. If an automated capacitor assembling system is

developed, this will increase the overall production of the company at a reduced time and rate. The team had the options of choosing between fully automated assembly design or semi-automated assembly design, but the team has decided to go with the semi-automated design. This will require the help of an operator along the assembly line process; however, the added automated steps will still improve the assembly time by 50%.

Part of the assembly steps that will be automated is the cutting and placing of the tape between each capacitor, wrapping of 8.31” insulation material around the assembled capacitor and the one time dimensional check of the capacitor. The current design idea is to develop a rolling mechanism that would roll the double sided tape over the top of the three capacitors at once, a functional gauge that will guide the operator by maintaining the dimension of the capacitors while stacking them, a mechanism to quickly wrap the insulation paper around the capacitor stack, and also a final dimensional gauge with a cut-out section of maximum allowance for a one time dimensional check of the assembled product.

Within the next few weeks, the team hopes to come out with more design ideas and CAD drawings that gives a better description of each automated process.

References

- [1] http://www.globalspec.com/learnmore/manufacturing_process_equipment/manufacturing_equipment_components/capacitor_assembly_machines
- [2] K. Walker, "Senior Design Project Definition" pages 3-4.

Biography

Marissa Foreit is the team leader for this group. She is a senior in Mechanical Engineering at Florida State University and hopes to go into the manufacturing industry after graduation. Her experience includes an internship with Schmid Tool and Engineering this past summer.

Olayinka Oladosu is an exchange student of Florida Agricultural & Mechanical University from Federal University of Technology, Akure, Ondo State, Nigeria. He plans to complete his Bachelor's degree in Materials Engineering, attend graduate school to pursue a Master's degree and Phd. in Materials Engineering. He interned for Nigerite Limited and Sumo Steels Limited, Lagos, Nigeria. Plays soccer & Plans to work in an Oil & Gas multinational company after graduation.

Kyler Kazmierski was born and raised in Saint Augustine, FL and is currently a senior Mechanical Engineering student enrolled at Florida State University. After graduating in the Spring of 2017 with his Bachelor's degree, Kyler plans to obtain a full time job in the industry.

Folaranmi Adenola is an exchange student from Florida Agricultural and Mechanical University from Federal University of Technology Akure, Ondo State. He plans to complete his bachelors in Metallurgical and Materials Engineering. He interned in 7up Bottling Company (Pepsi Nigeria) and he is currently involved in a research of Microwave assisted HTL and hydrocracking of winery waste for nutraceutical and biofuel extraction. He plans to attend graduate school to pursue a master's in Industrial Engineering.