



FAMU-FSU College of Engineering

Team Members: Jose Arita, Brian Baker, Adonis Costa, Guido De Souza, Michigun Joseph, Jose Pacheco, Macklin Tweedie **Reviewers:** Dr. Bruce Harvey, Dr. Simon Foo **Instructor:** Dr. Jerris Hooker **Advisor:** Dr. Petru Andrei **Visual Reviewer:** Mrs. Faye Gibson **Sponsor:** ECE Advisory Board

Background

The FAMU-FSU College of Engineering administration and staff have raised concerns about the futility of their efforts to inform students about important topics. While Communication and Multimedia Services (CMS) is in the midst of upgrading the College of Engineering website, the Electrical and Computer Engineering (ECE) Advisory board has suggested a parallel approach: the creation of an interactive and informational kiosk.

Motivation

The concept is to create an Android application within Android OS that allows ease of access for all users while delivering important information about the College of Engineering. Design-wise, the kiosk will feature an interactive opportunity for visitors, students, staff and faculty effectively giving the College of Engineering a more modern feel. Students will benefit from the kiosk as it will reduce the amount of information that is lost through other delivery methods while also providing opportunity to get involved within the campus. The ECE faculty also benefits from the reduction of advising strain while simultaneously laying groundwork for a department-specific informational center made by their own students.

Objectives

- Deliver relevant information about courses offered, faculty, events, and organizations more efficiently compared to emails, flyers, etc. for students, faculty and staff.
- Showcase student talent and the campus's technological edge.
- To create a wall mounted kiosk that is ADA compliant to accommodate all users without restriction or strain.
- To create a software environment that promotes scalability and ease of use through an application that is built from the ground up.

Wall Mounting

- Restricted to a max 4 inch protrusion off of the wall to meeting ADA requirements
- Vertical Orientation of monitor to accommodate more eye levels and allow for more comfort in viewing
- The orientation equally provides more physical access in terms of reach with more touch point height

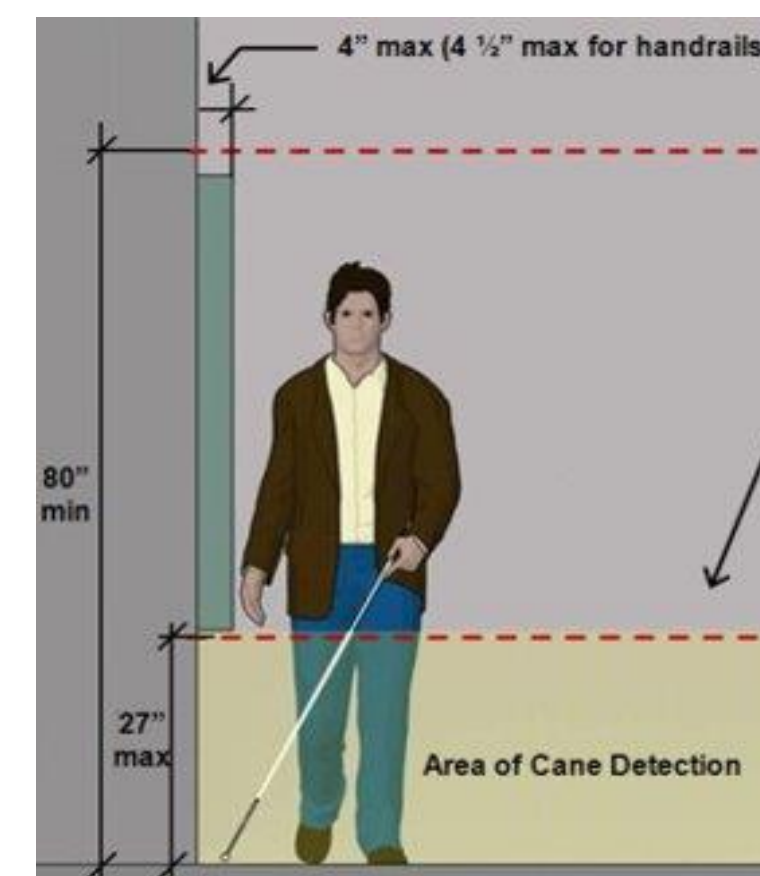

Ergonomics

- Kiosk is compliant with Americans with Disabilities Act (ADA) specifications
- Goal: to guarantee that the kiosk can be used by users with mobility limitations and hearing/vision impairments at the same level as users with no physical disabilities



Design

Mount

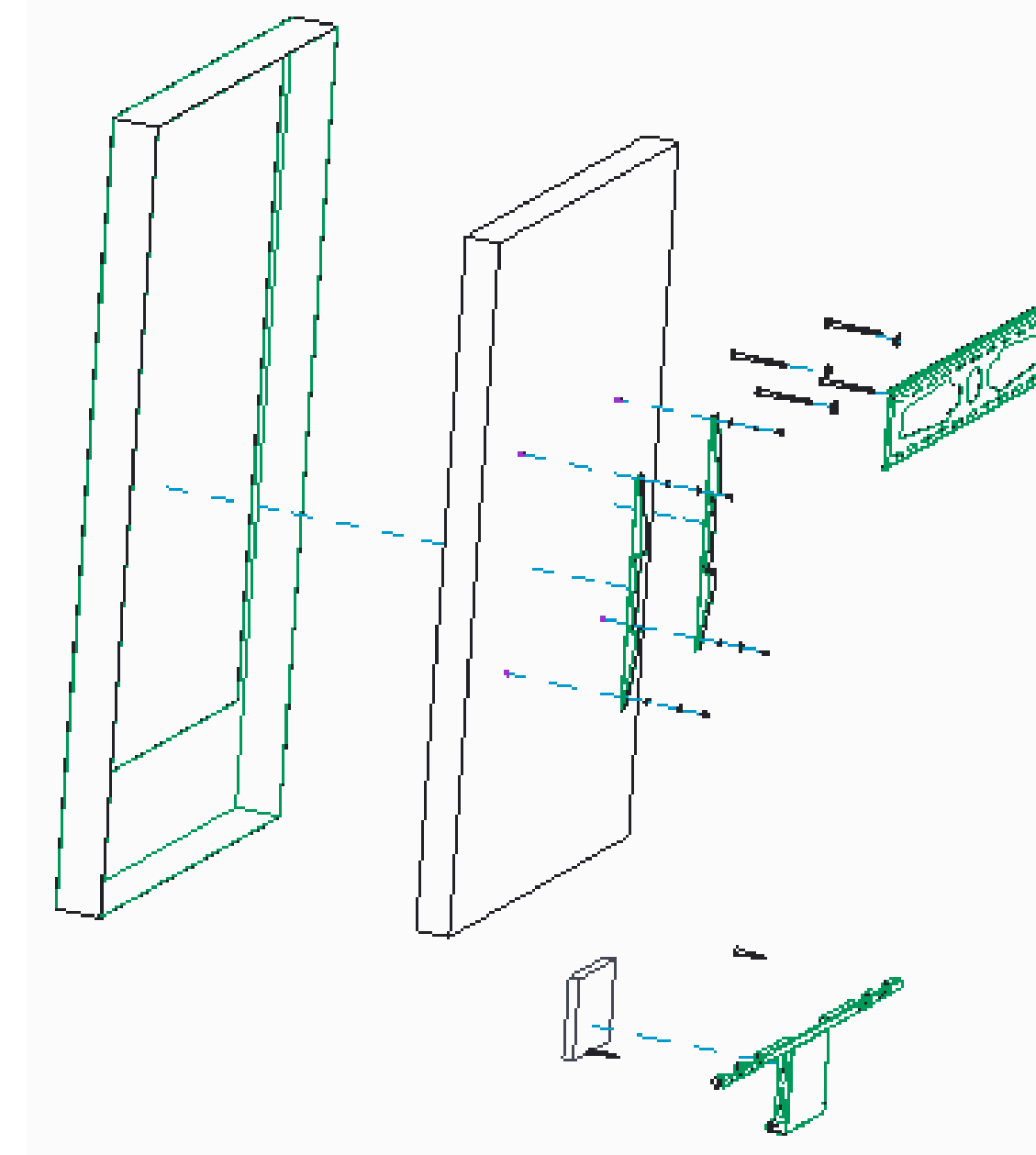

TV Display



Features Wanted

Feedback received from surveys done with over 150 possible users, consisting of students, faculty and visitors.

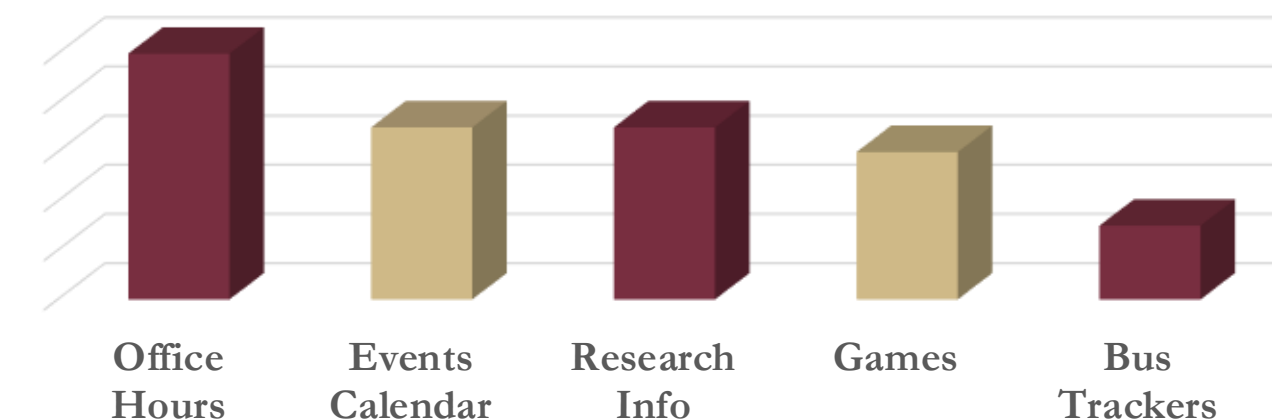

Hardware

- Display – Samsung DB55E
- 55 inch High Definition TV
 - Full HD (1920 x 1080)
 - Oriented vertically to allow for reach by various heights
 - Business class – can operate for 20 hours a day



- Touchscreen – TSI Touch
- Infrared (IR) overlay
 - Designed specifically for DB55E
 - Provides up to 10 simultaneous touch points
 - Also provides protection for TV
 - Integrated casing and glass screen cover

- Android TV Device – TX3 Mini
- Powers Android application
 - Connects to TV via HDMI
 - USB connects to touchscreen
 - Ethernet port for internet



Software

- The Android TV device runs an Android app that has touchscreen controls
- Home menu will feature six major menus
 - Each will have sub-menus as detailed to the right
- Virtual button to move controls down for users with less reach

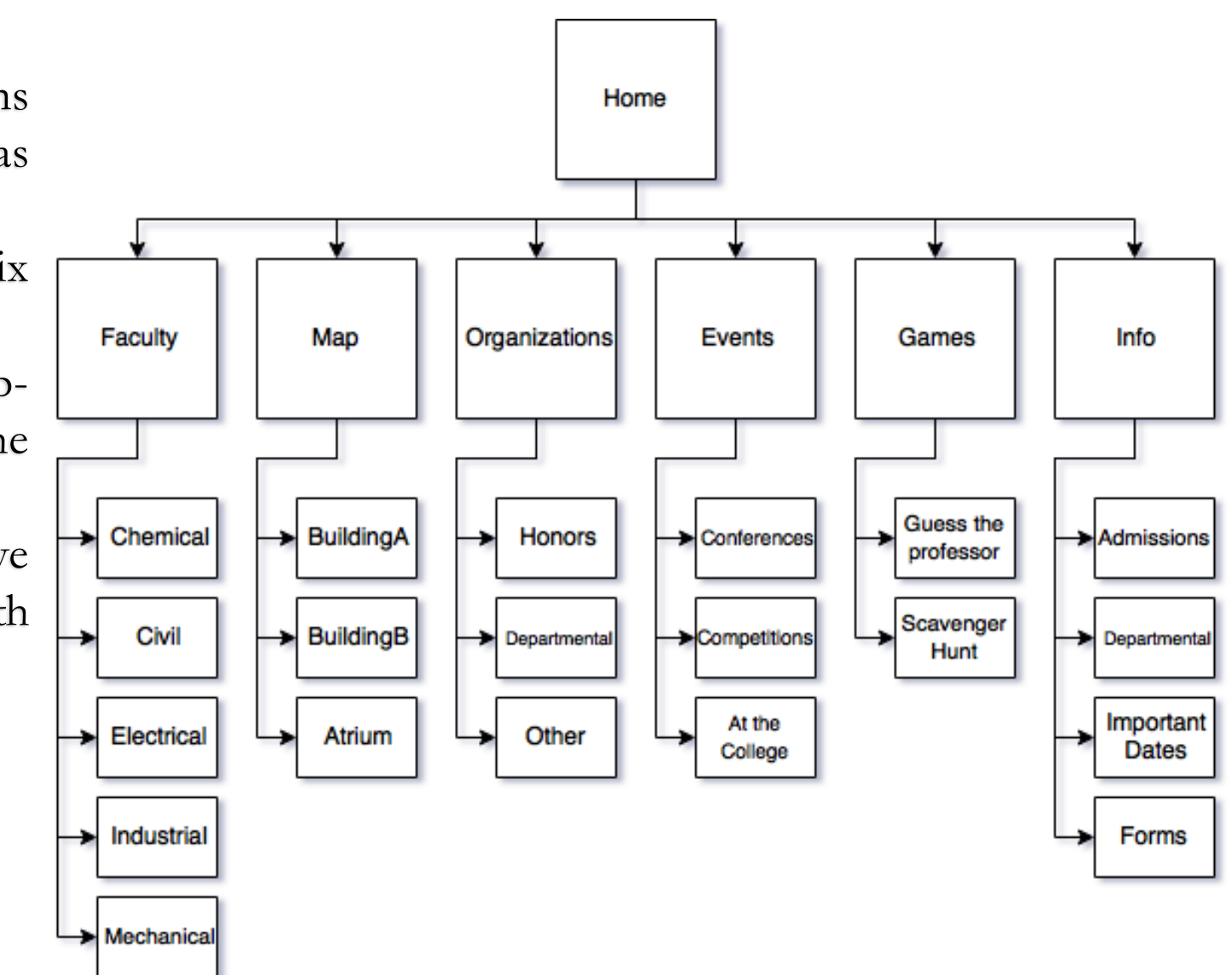

Target Results

Metric Number	Need	Metric	Imp.	Units	Marginal Value	Ideal Value	Status
1	An Interactive Screen	Touch Screen	Very High	Inch	20"-90"	48"	55"
2	Information Hub	Subjective	Very High	N/A	N/A	N/A	Satisfactory
3	Internet Connection	Reliable Connection	Very High	N/A	N/A	N/A	Satisfactory
4	Protected Against Theft & Tampering	Binary (Yes or No)	High	Condition	Wear and Tear	Unbroken	Satisfactory
5	Wall Mounted	Center Height	High	Feet	3'-5'	4'	Satisfactory
6	Good Experience	Subjective	High	N/A	N/A	N/A	TBD
7	Schedule Appointments	Meetings, etc.	High	N/A	N/A	N/A	TBD
8	Scalability	Subjective	High	N/A	N/A	N/A	Satisfactory
9	Screen Display	Resolution	Medium	Pixels	1080p-2160p	2160p	Satisfactory
10	Audio	Speakers	Medium	Decibels	40-60 dB	50 dB	Satisfactory
11	Highlight ECE Department Innovation	Subjective	Low	N/A	N/A	N/A	TBD

Conclusion

The primary objectives of the project this year were to establish a user friendly interface and create an aesthetically pleasing design. These tasks were completed. Some of the secondary objectives of the project included providing a solid foundation for the project for years to come as well as creating a draw to the kiosk. We believe we have also completed these tasks. The groundwork has been laid to keep growing this project for years to come.

Future Work

- Interface Kiosk App with College of Engineering Website through Drupal API
- Voice recognition
- Facial recognition
- Text to speech software
- Holograms
- Student ID swipe accessibility
- Adjustable mounts
- Printing capabilities

Acknowledgement

The Kiosk Team thanks the following individuals for their guidance, support, and constructive criticism on this project:

- Dr. Jerris Hooker
- Dr. Shayne McConomy
- Dr. Simon Foo
- Dr. Bruce Harvey
- Mrs. Faye Gibson
- Dr. Petru Andrei
- ECE Advisory Board