



FAMU-FSU
Engineering

SoutheastCon 2020 Hardware Competition

Virtual Design Review 5



Team Introductions



Isabel Barnola
*Lead Software
Engineer*



David Bowen
*Lead Robotics
Engineer*



Diego Campos
*Lead Signal
Process Engineer*



Alex Ndekeng
*Lead Power
Systems
Engineer*



Abiel Souverain
*Lead Design
Engineer*

Sponsor and Advisor



FAMU-FSU
College of Engineering



Engineering Mentor
Jerris Hooker, Ph.D.



Academic Advisor
Bruce A. Harvey, Ph.D.



Objective

The objective of the project is to build an autonomous robot with the capabilities of completing at least one of the two challenges set for the 2020 SoutheastCon hardware competition.

Alex Ndekeng



Project Background

Alex Ndekeng

2020 Southeast Con hardware competition

- 1st challenge: accurately stack Lego Duplo blocks representing the digits of pi.
- 2nd Challenge: push buttons in an order that represents the digits of pi

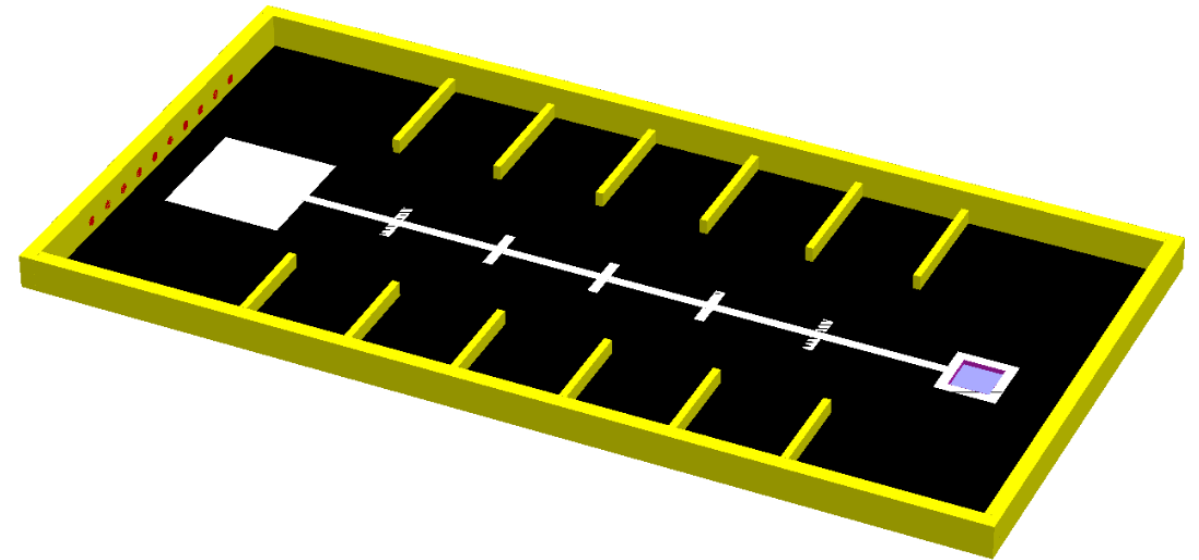

Description	Number of points
Total stack sequenced correctly	$20 * N * N$
Additional stack not sequenced correctly	$N * N$
Total button presses sequenced correctly	$10 * N$
Additional button presses not sequenced correctly	N (max of 100 counted)

Alex Ndekeng

Customer Needs

- We're having our customers be the same as our primary and secondary markets as well as our stakeholders
- 12"x12"x12" autonomous Robot
- Ability to pick up to pick up Lego blocks and stack them
- Ability to stack Legos or push buttons in the order of the numbers of pi
- Navigate through the arena

Alex Ndekeng

Built Practice Playfield

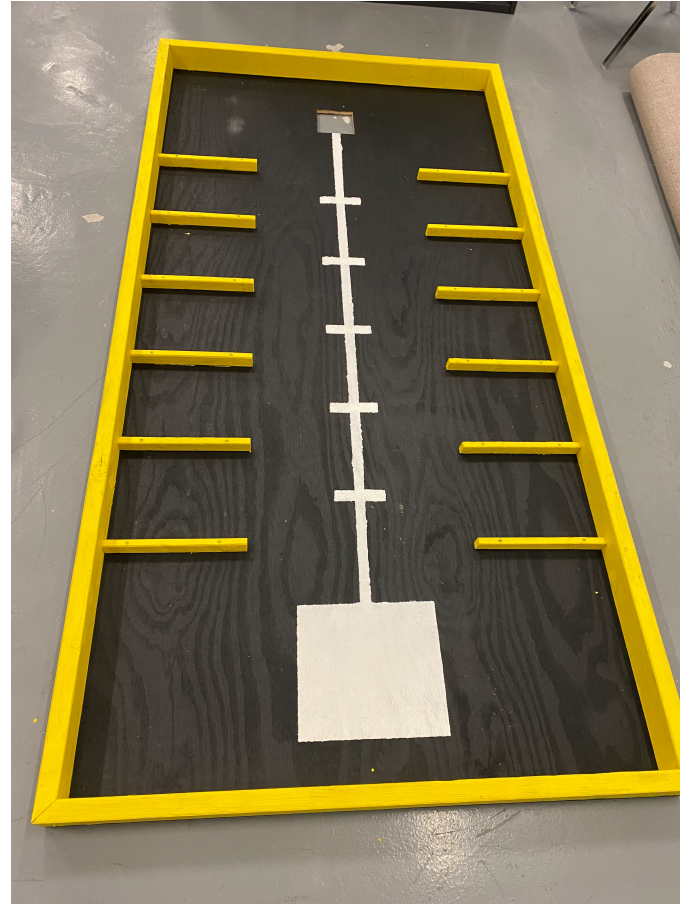

Components

Abiel Souverain

Ezio

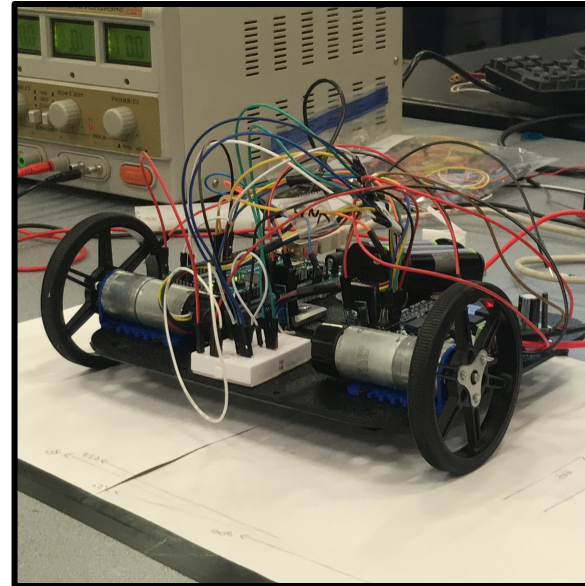
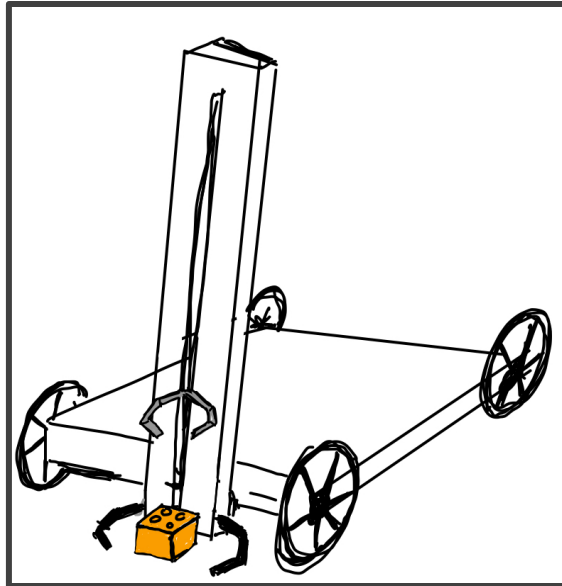

Abiel Souverain

Components

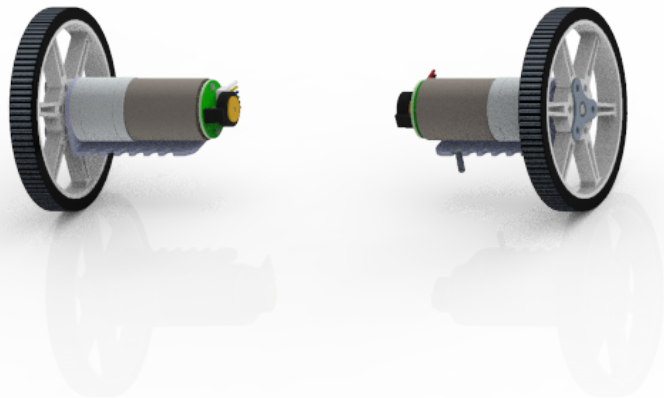

- Driving Motors – 99:1 gearbox
- Wheels – 80x10mm
- 6V
- 6.5A Stall Current
- 1A Running Current

Abiel Souverain

Parallel Gripper



- Model is based on this gripper from Servo City

Abiel Souverain

Components

5.23 in

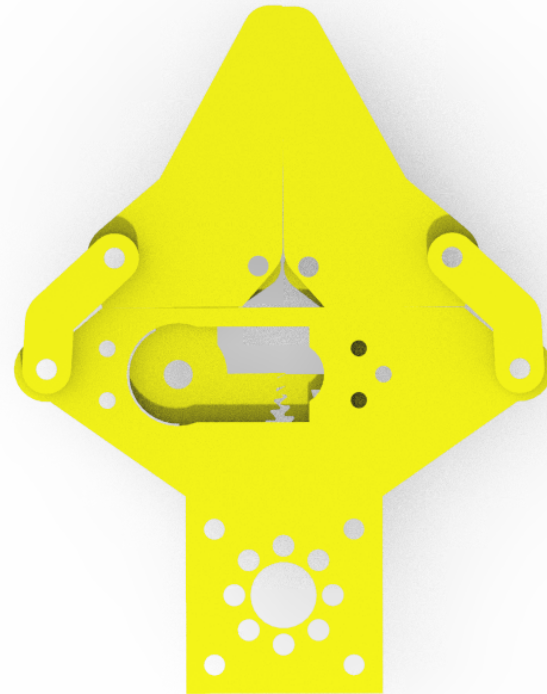

Lower Claw

5.30 in



Upper Claw

Abiel Souverain

Components – Laser cut bases

Lower
Base

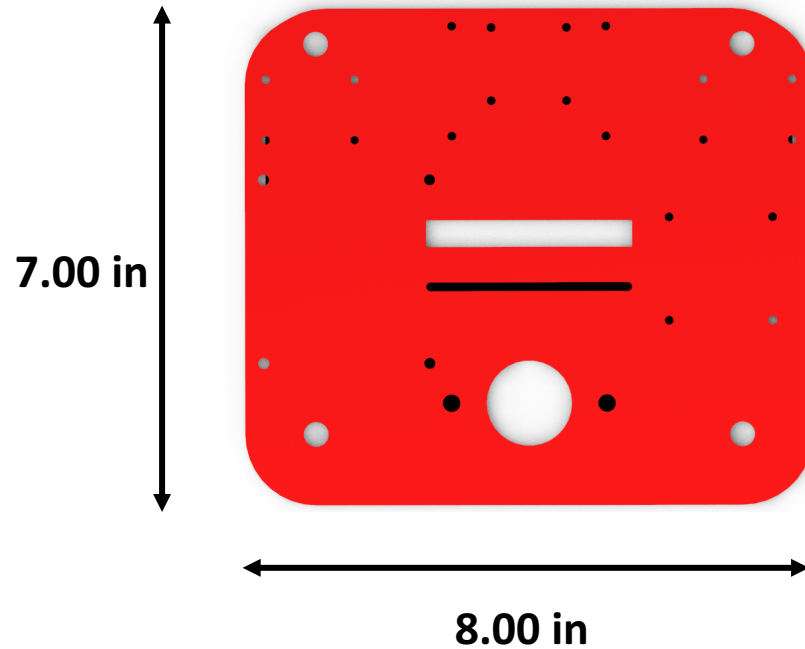

Upper
Base

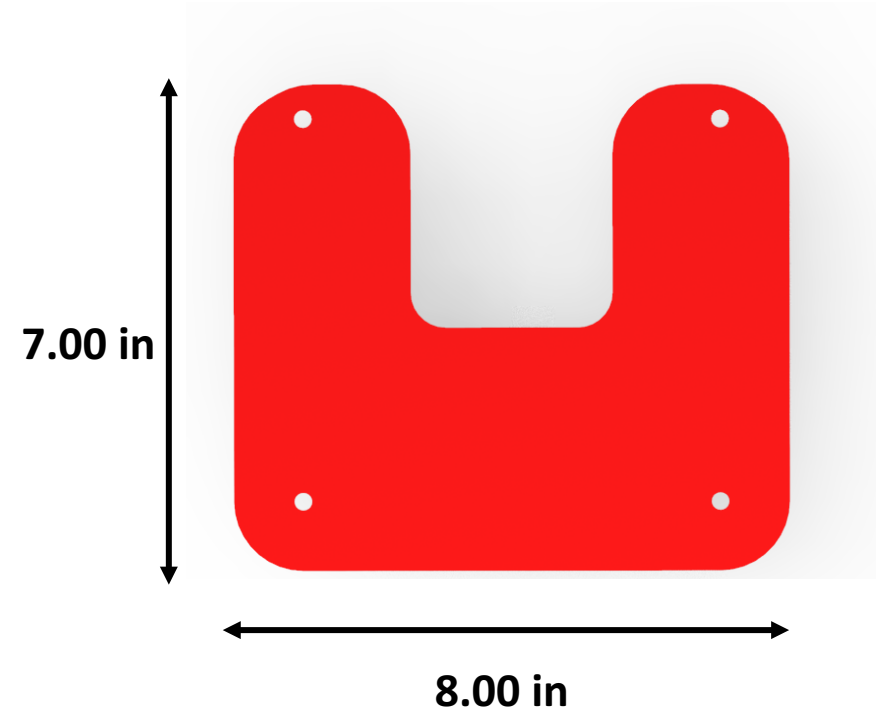

Abiel Souverain

Components

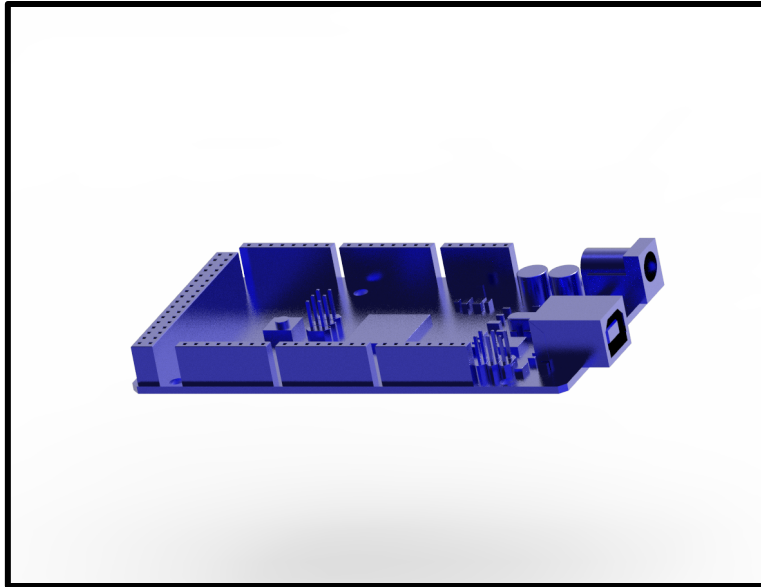

Arduino Mega

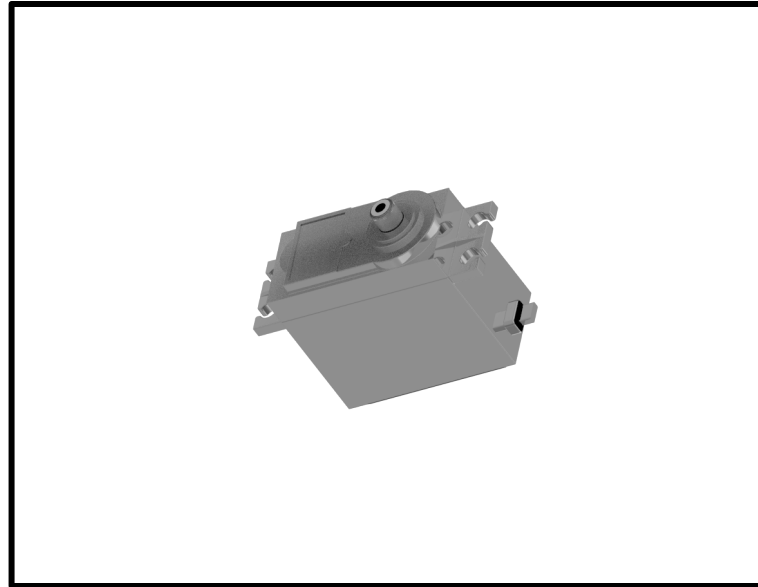

Servo Motor

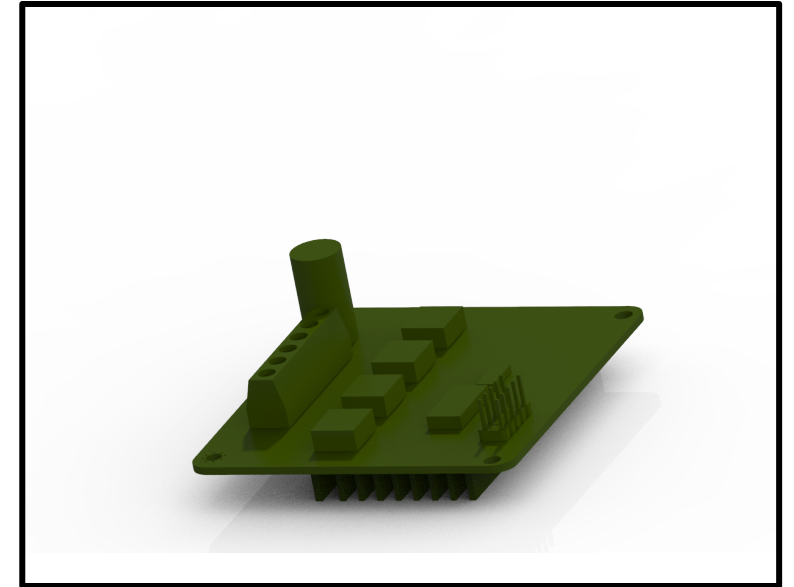

DC Motor Driver

Abiel Souverain

Components – Elevator Assembly

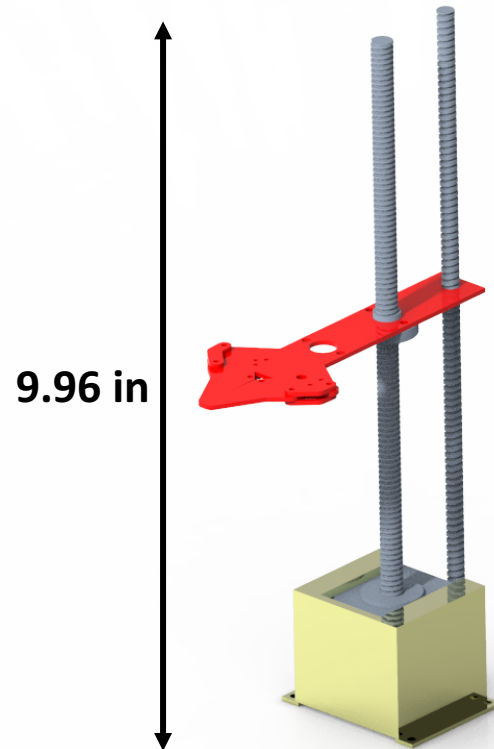

- Stepper motor with lead screw
- Geared Claw – servo controlled
- Guide Rod

Abiel Souverain

Wiring Diagram

Diego Campos

Wiring Diagram

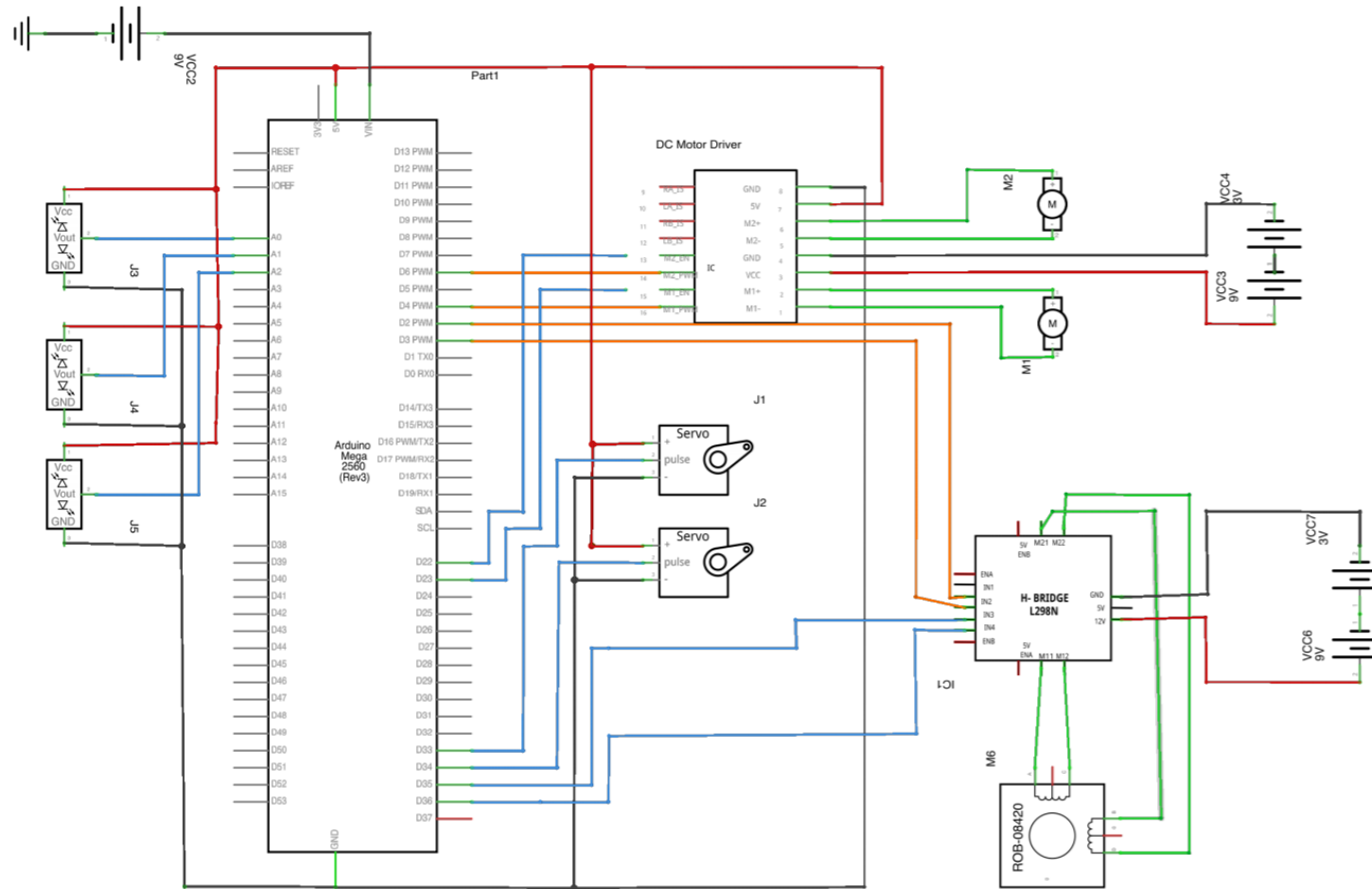

Diego Campos

Block Layout for 7 numbers

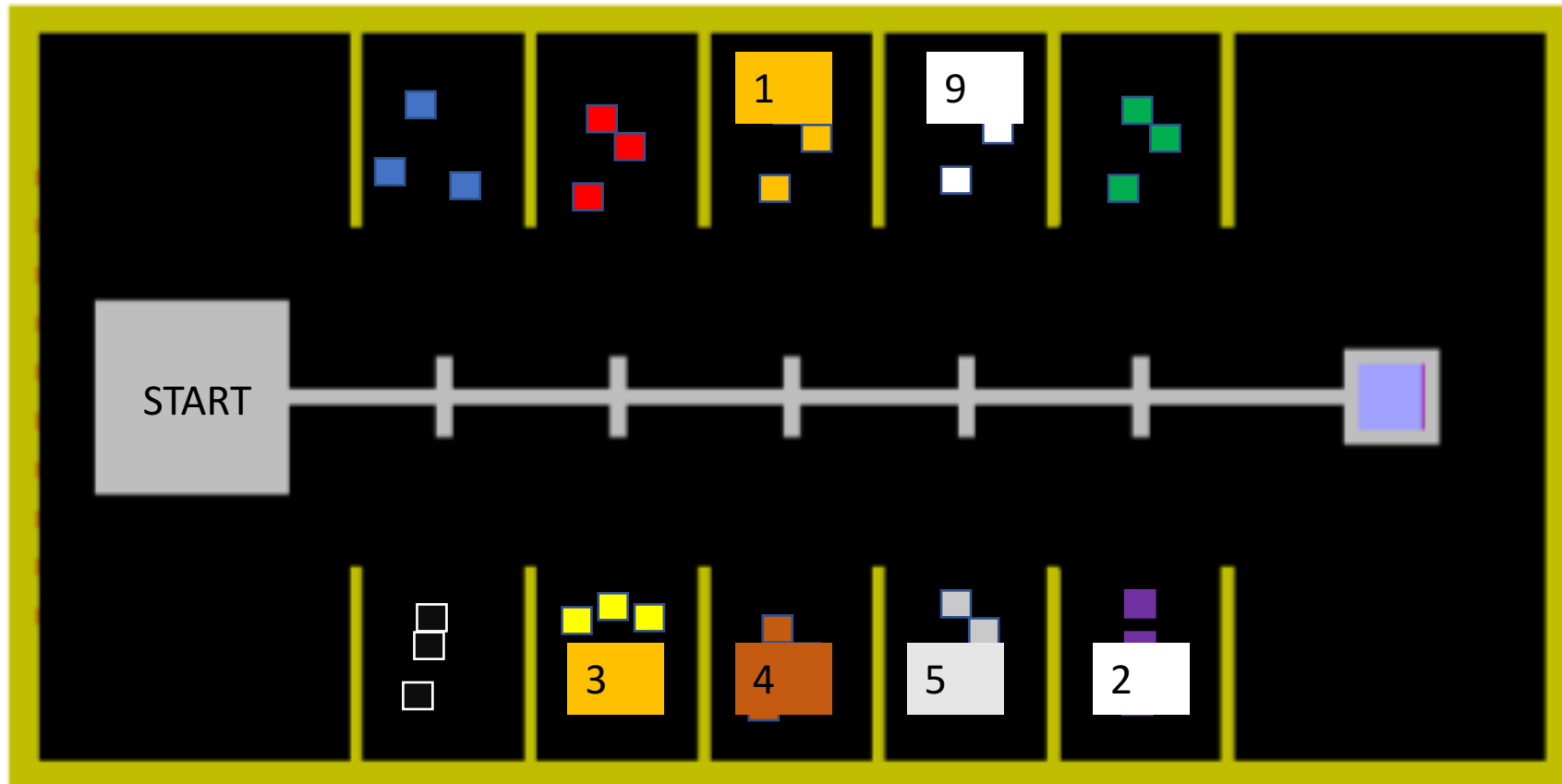

Diego Campos

Block Layout for 10 numbers

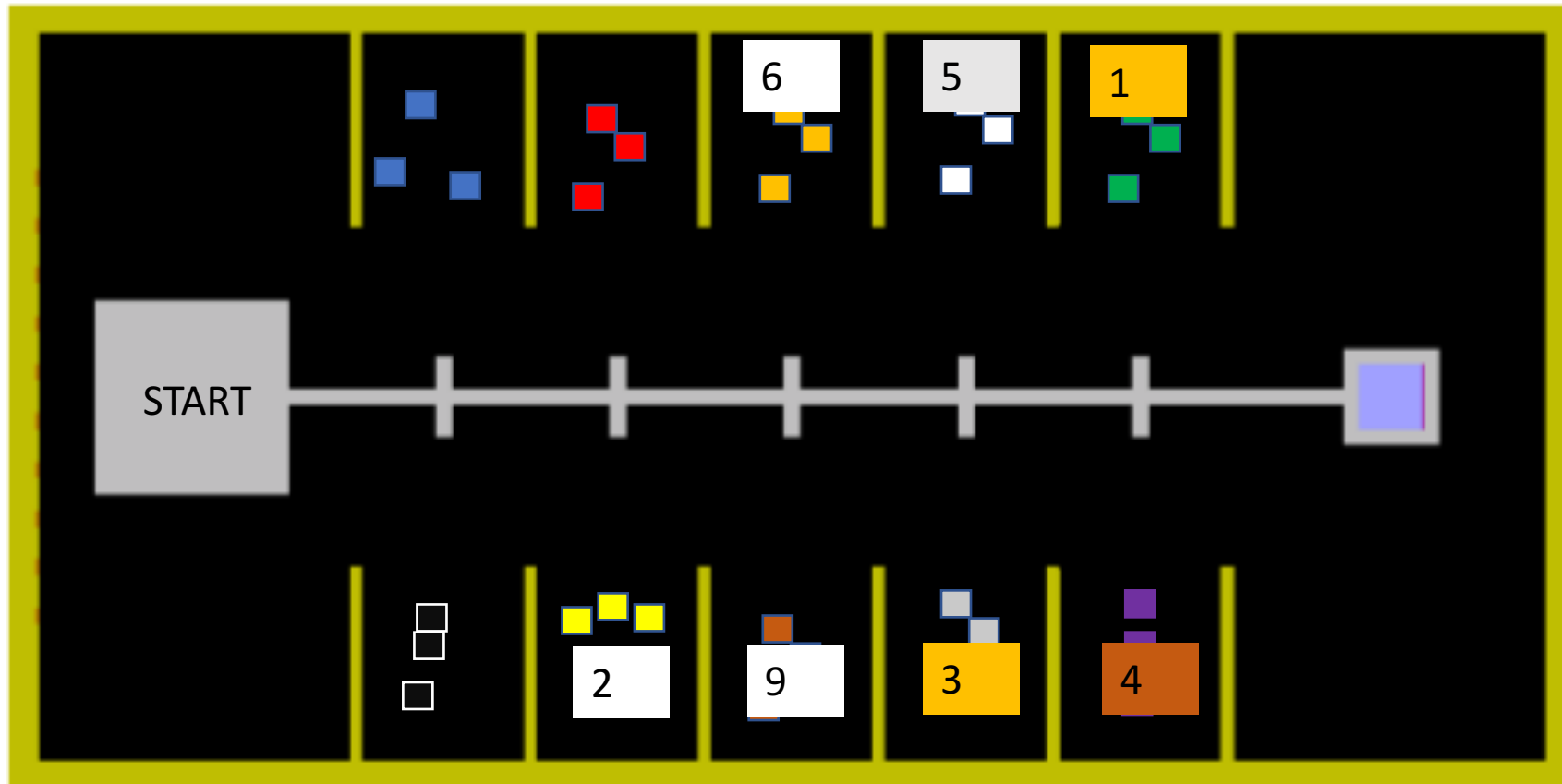

Diego Campos

Code

Isabel Barnola

Pseudocode – 7 blocks

```

1  stacking_challenge()
2  {
3      // Block 3
4      line_following(n = 2) // navigate over n white lines
5      turn(right)          // rotate - 90 degrees
6      stacking()           // Stack lego - Value = 3
7      position = 2
8      // Block 1
9      turn(left)
10     line_following(1)
11     turn(left)
12     stacking()
13     position = 3
14     last_stack(position,left) // check if time == deadline - go to end
15     // Block 4
16     turn(right)
17     turn(right)
18     stacking()
19     position = 3
20     last_stack(position,right) // check if time == deadline - go to end
21     // Block 1
22     turn(left)
23     turn(left)
24     stacking()
25     position = 3
26     last_stack(position,left) // check if time == deadline - go to end
27
28     // Block 5
29     turn(right)
30     line_following(n = 1)
31     turn(right)
32     stacking()
33     position = 4
34     last_stack(position,right) // check if time == deadline - go to end
35     // Block 9
36     turn(left)
37     turn(left)
38     stacking()
39     position = 4
40     last_stack(position,left) // check if time == deadline - go to end
41     // Block 2
42     turn(right)
43     line_following(n = 1)
44     turn(right)
45     stacking()
46     //END
47     turn(left)
48     line_following(n =1 )
49     stacking()
50     drive_backwards()
51 }

```

Isabel Barnola

Pseudocode – Main functions

```
line_following(int num_lines)
{
    // follow line
    // count vertical lines
    // stop when count = num_lines
    // uses turn_l, turn_r,
    //     advance and stop
}

turn (int direction) // right or left
{
    // turn 90 degrees to direction
    last_stack(int position,int dir )
    {
        // not enough time - stack at the goal
        turn(dir)
        line_following(5-position)
    }
}
```

```
stacking()
{
    // aproach block until its detected
    go_to_block();
    pick_block()
    {
        // activate claw1
        // lead screw - down
        // deactivate claw2
        // lead screw - up
        // activate claw2
        // deactivate claw1
        // lead screw - up
    }
    // drive back to vertical line
    drive_backwards( num_turns)
}
```

Isabel Barnola

Main functions What is done?

What is done?

- Line_following ✓
 - Robot stops after line
 - Velocity has to be slowed down
 - IR sensors must be attached to interrupt
- Turn ✓
 - Robot turns very close to 90 degrees
- Last_stack() ✓
 - Combination of turn and line_following

To do

- Stacking()
 - go_to_block()
 - Pick(block)
- drive_backwards

Isabel Barnola

Line following - Testing

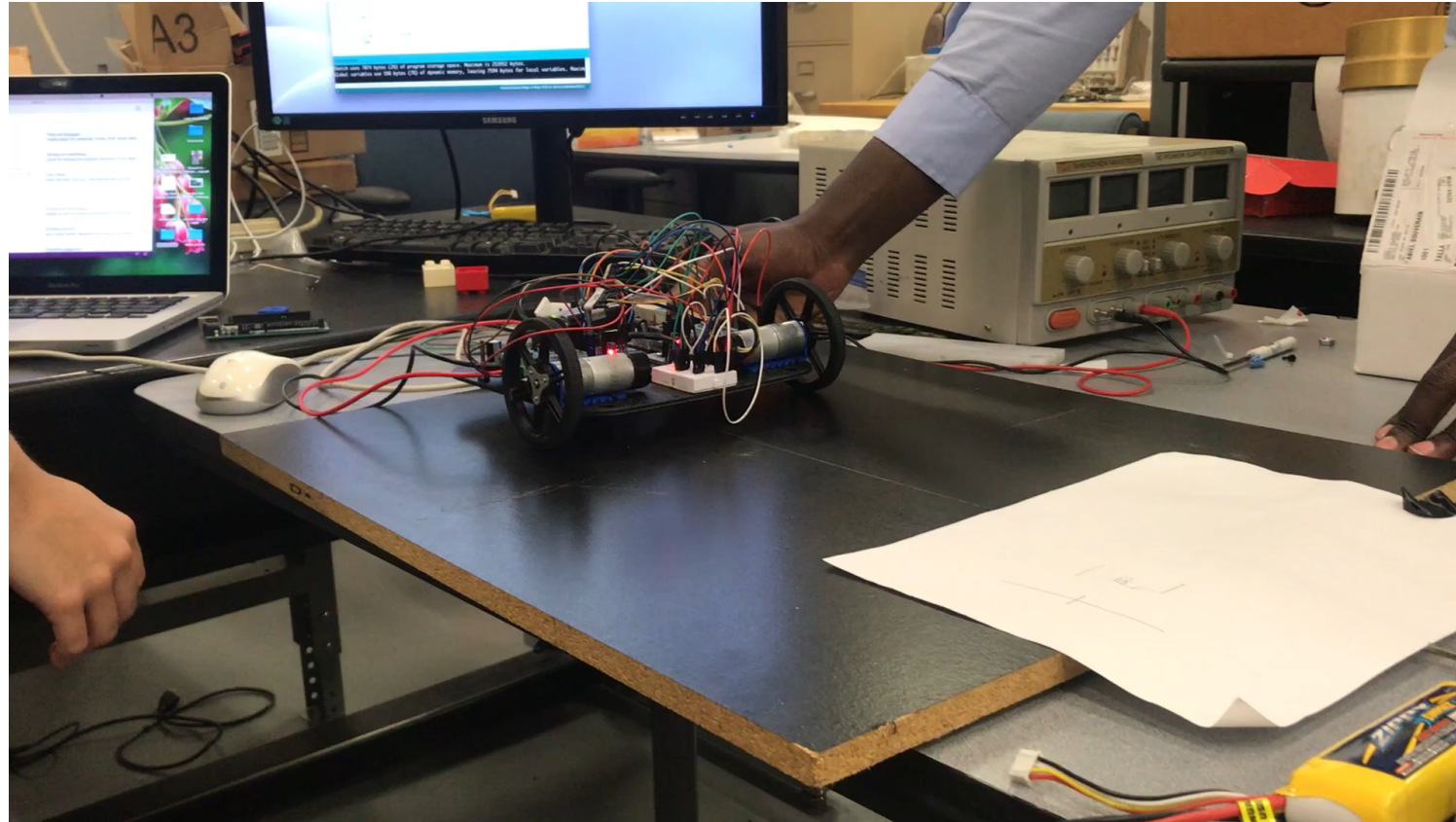

Isabel Barnola

Line Following - Testing

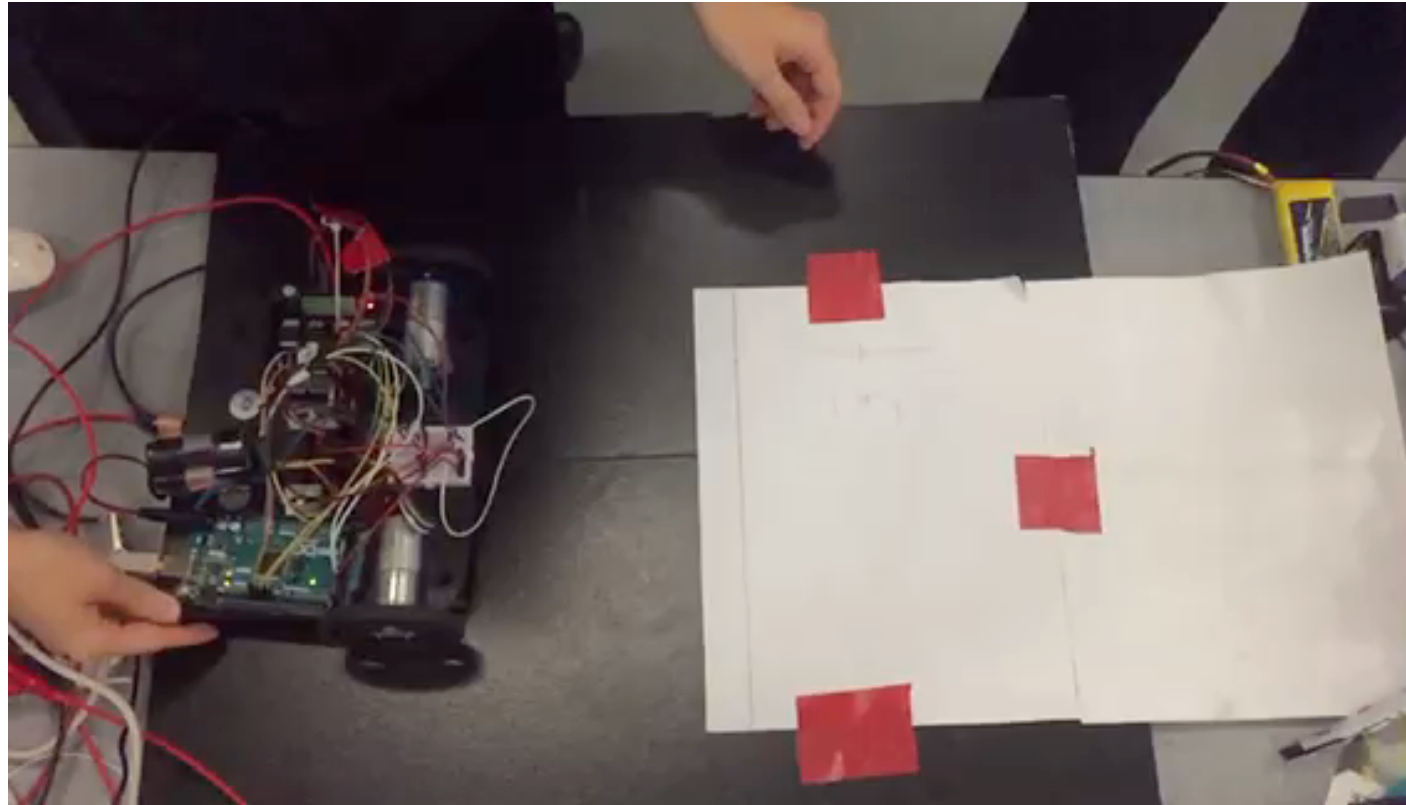

Isabel Barnola

Programming

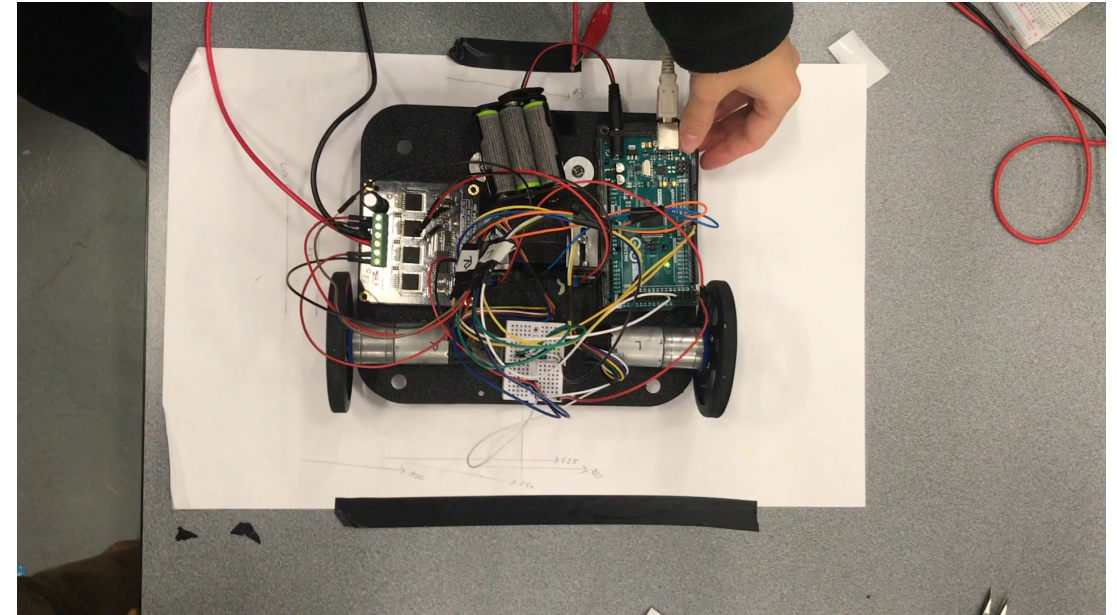
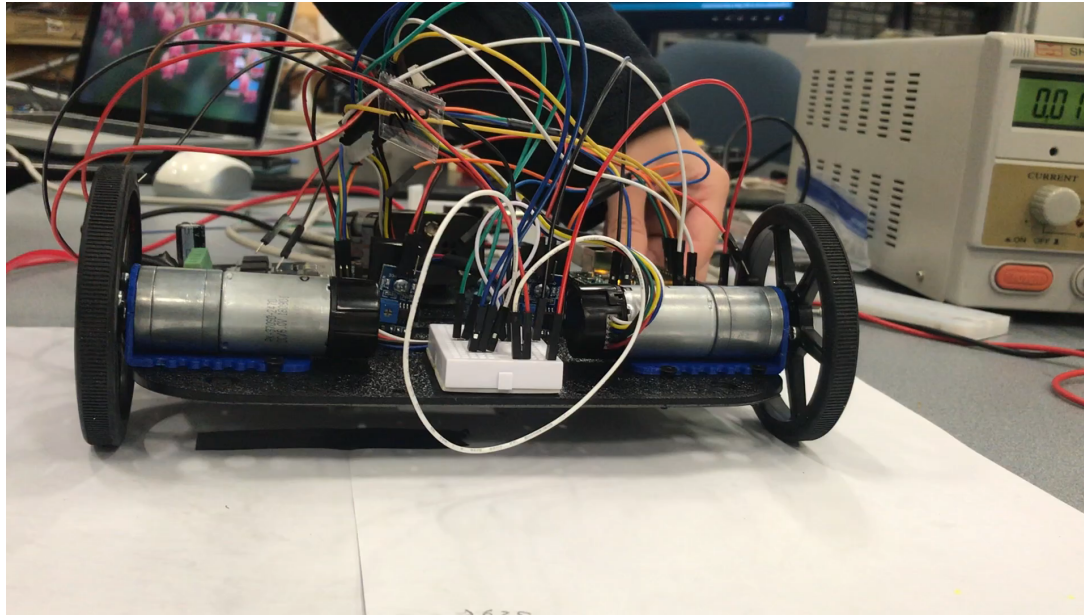

Isabel Barnola

Timeline

David Bowen

Timeline

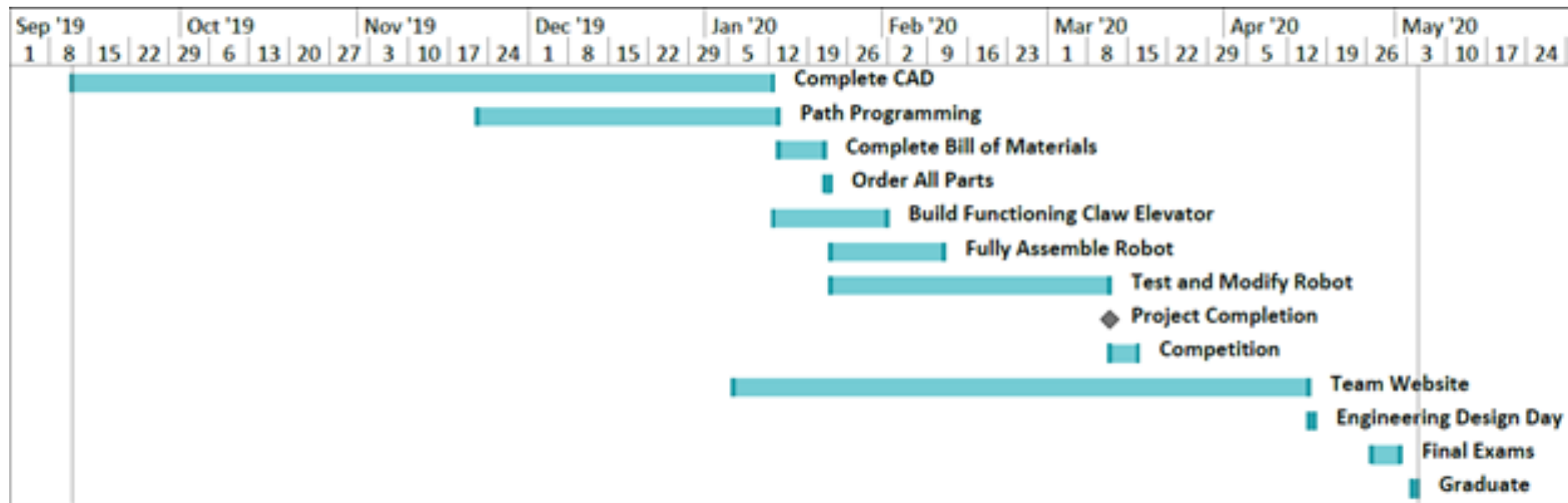

David Bowen

Revised Timeline

1. Programming – March 1, 2020
2. Functioning claw elevator – 1 week after parts arrive
3. Completed CAD – February 23, 2020
4. Fully assembled robot – Dependent on 2.
5. Competition – March 12-15, 2020

David Bowen

Obstacles

- Power/Batteries
- Path Programming
- Parts being shipped
- Encoders
- Motor speed

David Bowen



Parts Ordered

- Stepper motor with lead screw
- ABS sheets
- DC motor driver
- 12V High current battery pack
- 9V Batteries
- Hardware

David Bowen

4 Most Important Points

1. Discussed physical components
2. Discussed wiring and programming
3. Obstacles/revised timeline
4. Waiting on parts to arrive

David Bowen

Thank you for your time.

Team Email: southeastcon@admin.my.fsu.edu

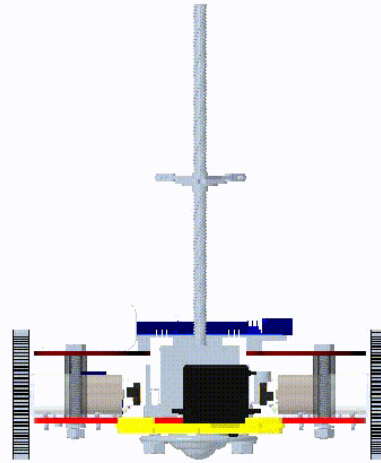

Review

Current Progress

Revised Timeline

Future Work

David Bowen

Backup Slides



Functional Decomp Backup







Concepts



Challenge

180
Seconds

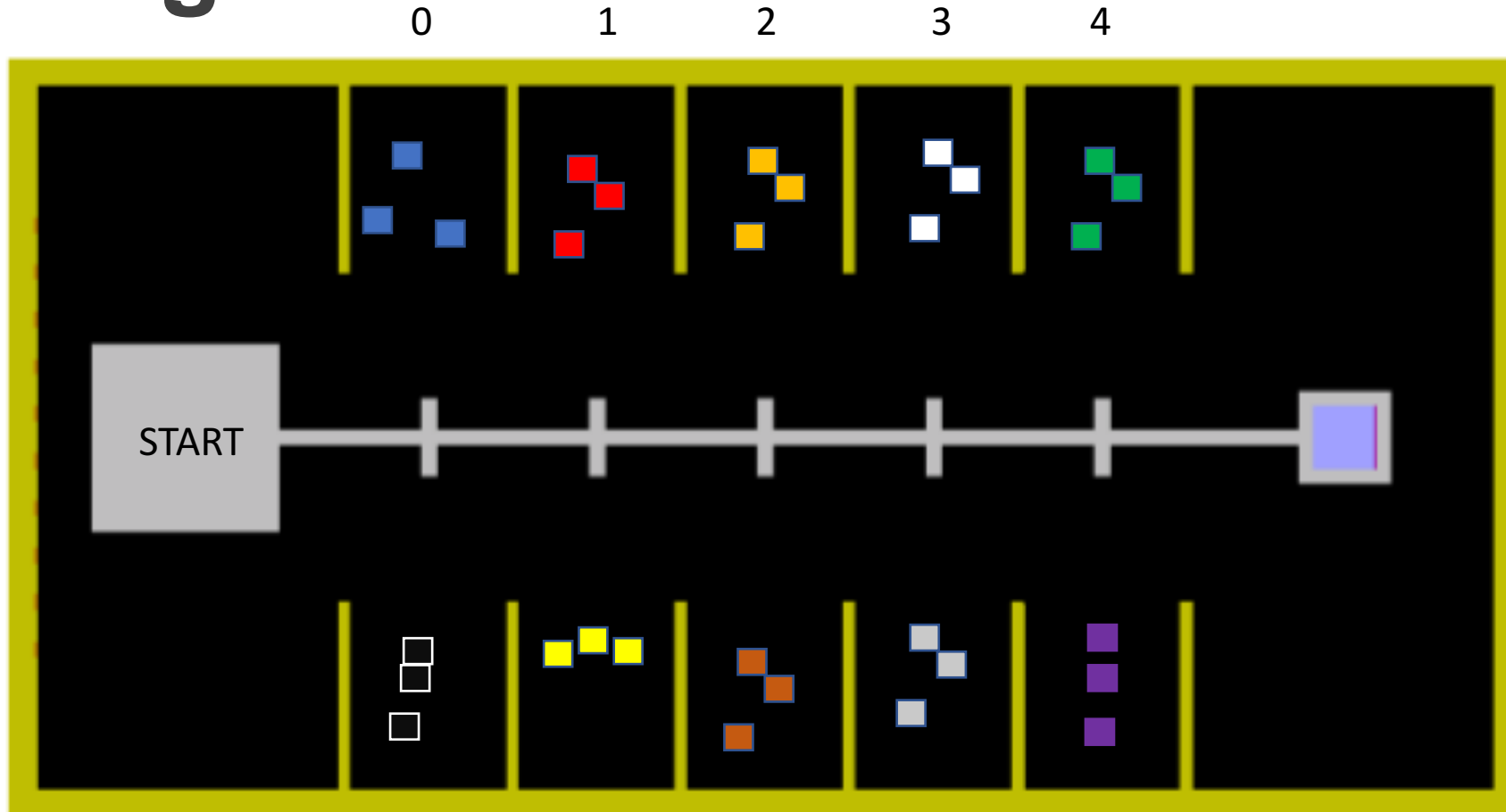

Concepts 1-2

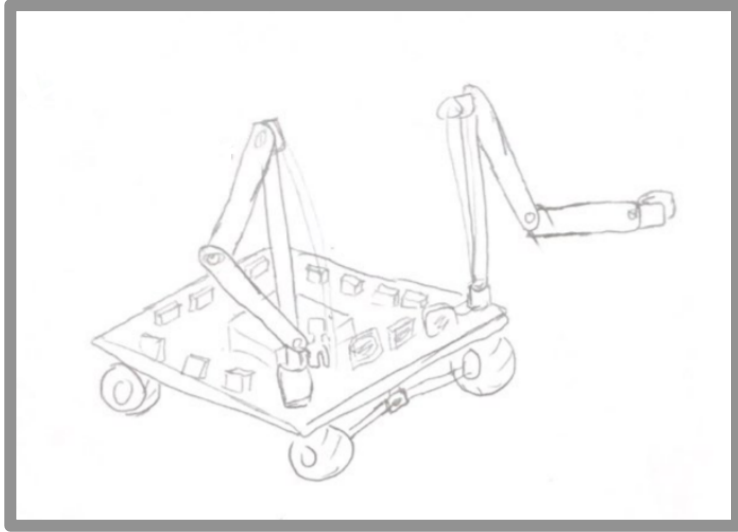

Robot with two arms

- 2 arms to hold the Lego and stack it and has a
- Hammerlike appendage on top of one arm.

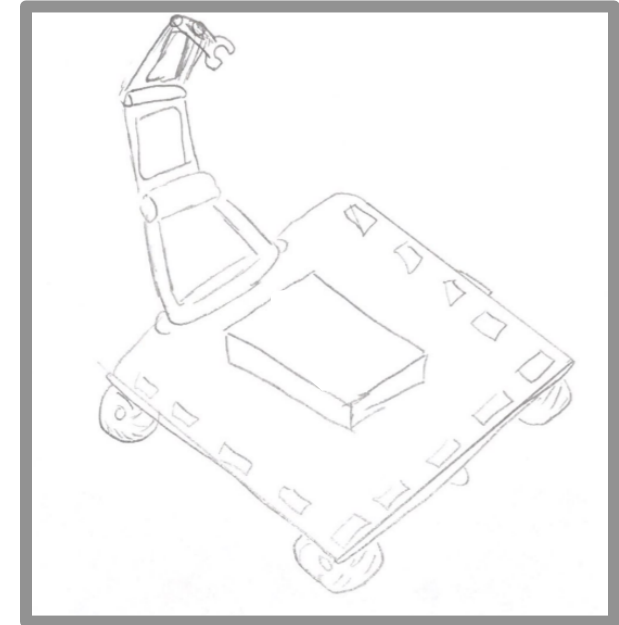

Scorpion

- 4 motors in the “tail.”
- Individual motors in wheels

Isabel Barnola

Concepts 3-4

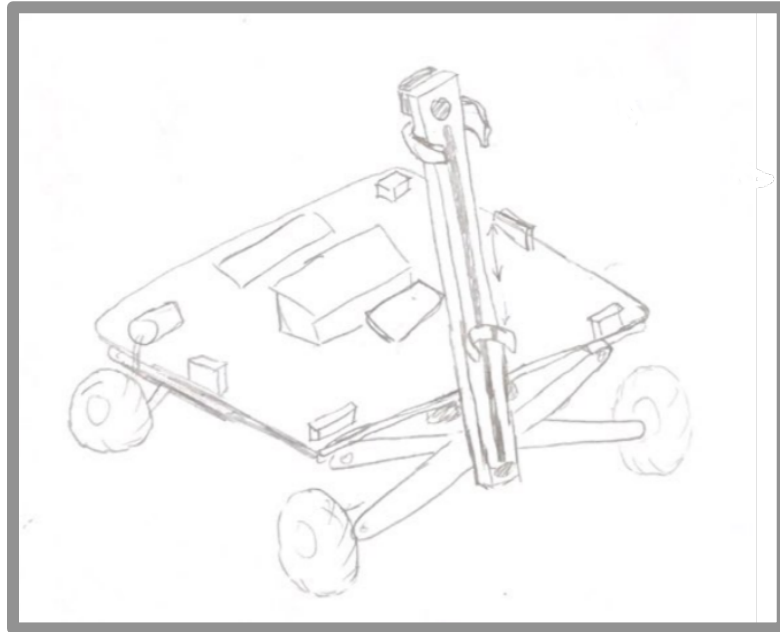

Robot with 2 claws and lift kit.

- Two claws to raise and lower blocks.
- It will find blocks using sonar.
- Lift kit.

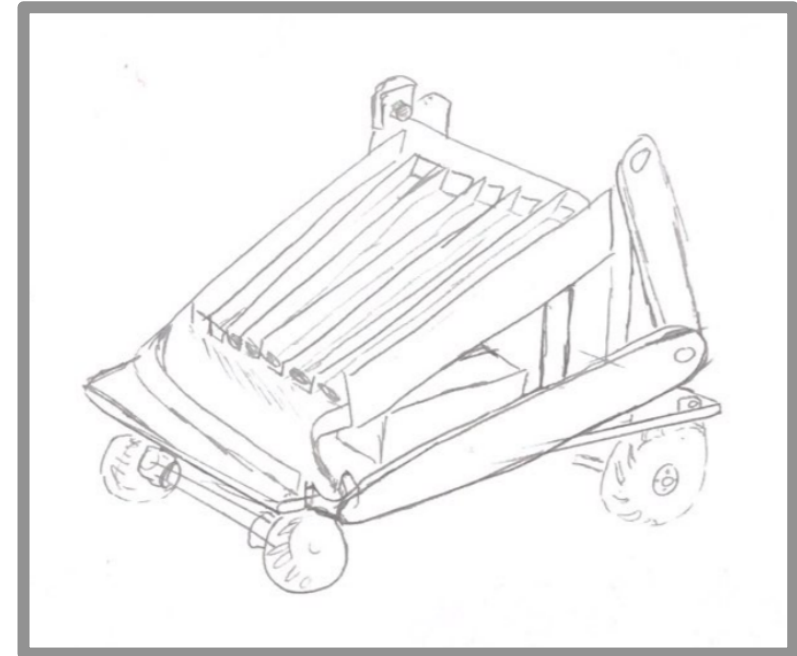

Color Sorting Robot

- Sorter on its body with blocks that slide in.
- Elevator and claw
- 3 DoF arm

Isabel Barnola

Concepts 5-6

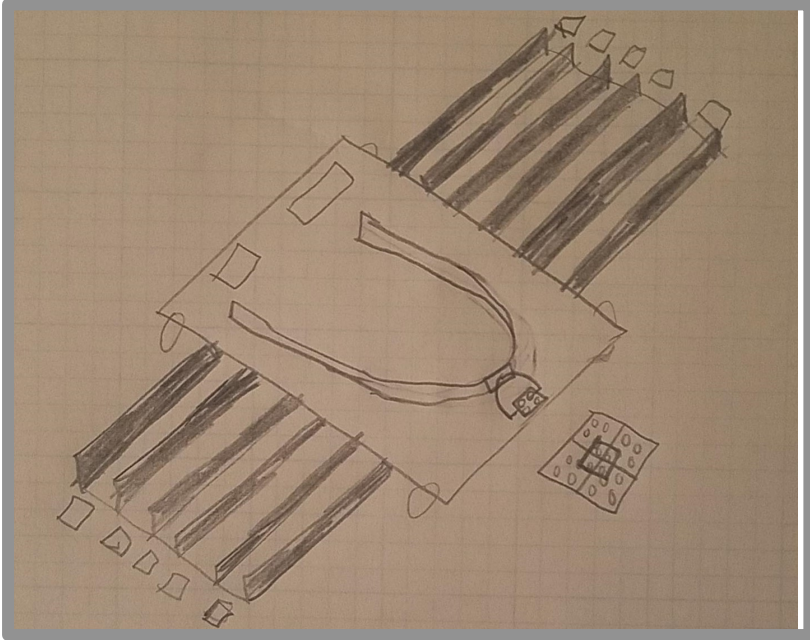

Slide System

- Slide system on either side to collect the blocks.
- Claw on a track to move grab the next block in the sequence and stack it.

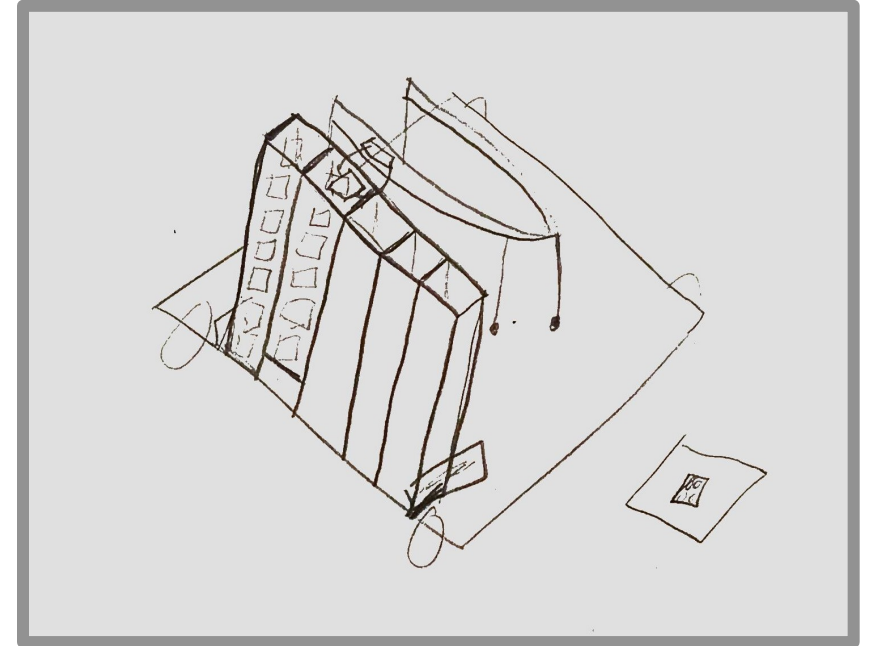

Spring Elevator

- spring-based elevator in 10 individual hoppers to store and supply bricks.
- It will have a claw track for stacking.

Isabel Barnola

Concept 7

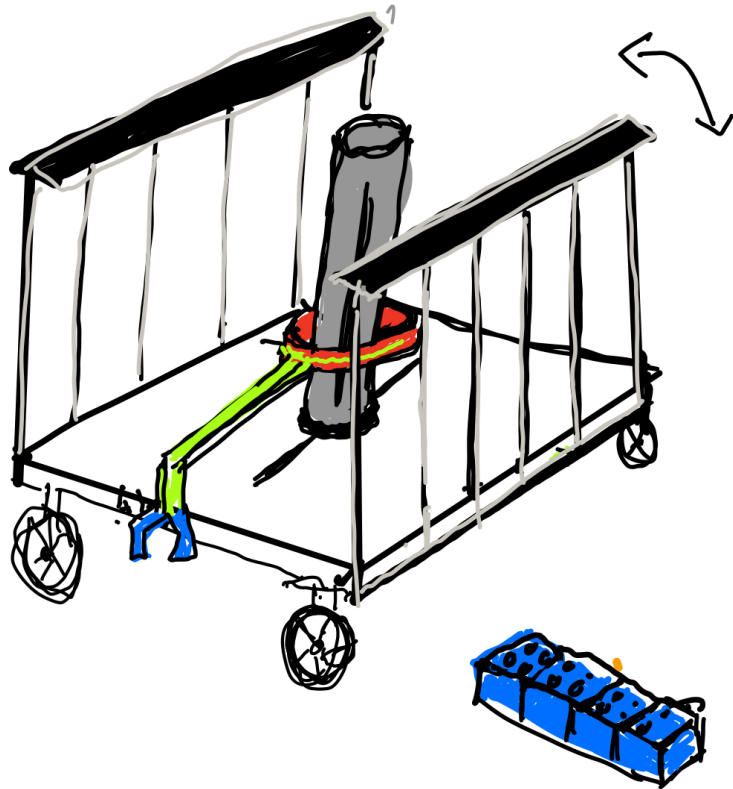

Stingray

- Net-like arms.
- Arms used to drag the Legos from the bins in an organized fashion to the base.
- From there an arm, composed of a lift and a claw that moves 360 degrees pick up the Lego blocks and stack them correctly on the base.

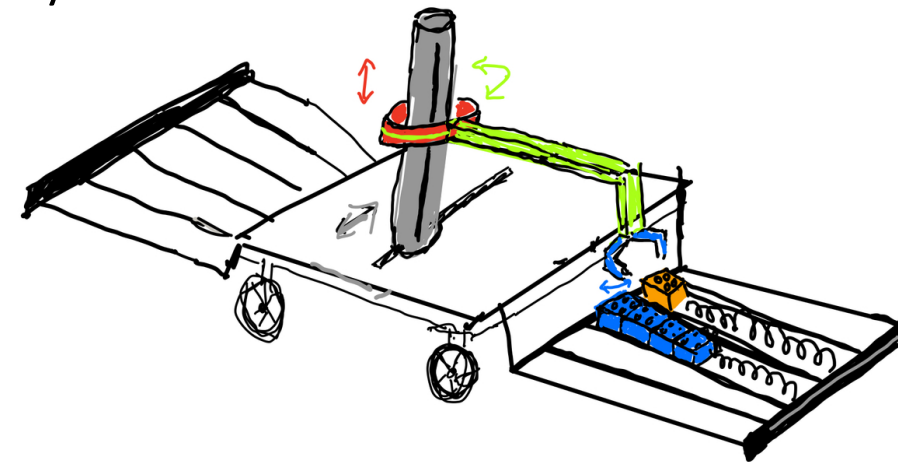

Isabel Barnola

Concept Selection Backup



Pugh Matrix

Engineering Characteristics	Datum	Weights	Scorpion	Robot w/ two arms	Claws and lift kit	Slide System	Spring based elevator	Stingray
Acceleration	0	1	1	1	1	1	0	-1
Distance from Barrier	0	1	1	1	1	0	0	1
Block Height	0	2	0	1	0	0	0	1
Time to reach correct bin	0	1	-1	-1	0	1	-1	0
End time behavior	0	1	1	1	1	1	0	1
Time to locate block within bin	0	1	0	-1	0	1	0	1
Total Score	-	-	2	3	3	4	-1	4
Rank	-	-	5	3	3	1	6	1

Pugh Matrix

Engineering Characteristics	Weights	Datum(Scorpion)	Robot with two arms	Slide System	Claws and lift kit	Stingray
Acceleration	1	0	-1	-1	-1	-1
Distance from barrier	1	0	0	-1	0	0
Block height	2	0	1	0	1	1
Time to reach correct bin	1	0	0	1	1	1
End time behavior	1	0	0	1	0	1
Time to locate blocks within bin	1	0	1	1	1	1
Total	-	-	1	1	3	4
Rank	-	-	3	3	2	1

Criteria Weights

	Acceleration	Distance from Barrier	Block height (raising and lowering)	Time to Reach Correct Bin (Color Determination)	End Time behavior	Time to locate block within bin
Acceleration	1.000	5.000	0.333	1.000	3.000	0.333
Distance from Barrier	0.200	1.000	0.333	0.333	1.000	0.200
Block height (raising and lowering)	3.000	3.000	1.000	1.000	1.000	0.333
Time to Reach Correct Bin (Color Determination)	1.000	3.000	1.000	1.000	5.000	1.000
End Time behavior	0.333	1.000	1.000	0.200	1.000	0.143
Time to locate block within bin	3.000	5.000	3.000	1.000	7.000	1.000
Sum	8.533	18.000	6.667	4.533	18.000	3.010

Criteria Weights

Criteria	Criteria Weights
Acceleration	0.157
Distance from Barrier	0.054
Block height (raising and lowering)	0.176
Time to Reach Correct Bin (Color Determination)	0.211
End Time behavior	0.065
Time to locate block within bin	0.337

Acceleration Ratings

	Datum - Color Sorting	Scorpion	Robot with two arms	Claws and lift kit	Slide system	Spring-based elevator	Stingray
Datum - Color Sorting	1.000	0.200	0.333	0.200	1.000	0.333	1.000
Scorpion	5.000	1.000	1.000	3.000	5.000	5.000	3.000
Robot with two arms	3.000	1.000	1.000	0.200	5.000	1.000	3.000
Claws and lift kit	5.000	0.333	5.000	1.000	5.000	3.000	3.000
Slide system	1.000	0.200	0.200	0.200	1.000	0.333	3.000
Spring-based elevator	3.000	0.200	1.000	0.333	3.000	1.000	3.000
Stingray	1.000	0.333	0.333	0.333	0.333	0.333	1.000
Sum	19.000	3.267	8.867	5.267	20.333	11.000	17.000

Distance From Barrier Ratings

	Datum - Color Sorting	Scorpion	Robot with two arms	Claws and lift kit	Slide system	Spring-based elevator	Stingray
Datum - Color Sorting	1.000	0.333	0.333	0.333	3.000	1.000	1.000
Scorpion	3.000	1.000	3.000	1.000	5.000	3.000	3.000
Robot with two arms	3.000	0.333	1.000	1.000	3.000	1.000	1.000
Claws and lift kit	3.000	1.000	1.000	1.000	5.000	3.000	1.000
Slide system	0.333	0.200	0.333	0.200	1.000	0.333	0.333
Spring-based elevator	1.000	0.333	1.000	0.333	3.000	1.000	1.000
Stingray	1.000	0.333	1.000	1.000	3.000	1.000	1.000
Sum	12.333	3.533	7.667	4.867	23.000	10.333	8.333

Block Height Capabilities (Raising and Lowering)

	Datum - Color Sorting	Scorpion	Robot with two arms	Claws and lift kit	Slide system	Spring-based elevator	Stingray
Datum - Color Sorting	1.000	1.000	1.000	0.333	3.000	0.333	3.000
Scorpion	1.000	1.000	1.000	0.333	3.000	1.000	1.000
Robot with two arms	1.000	1.000	1.000	0.200	1.000	1.000	0.333
Claws and lift kit	3.000	3.000	5.000	1.000	3.000	3.000	1.000
Slide system	0.333	0.333	1.000	0.333	1.000	0.333	0.333
Spring-based elevator	3.000	1.000	1.000	0.333	3.000	1.000	1.000
Stingray	0.333	1.000	3.000	1.000	3.000	1.000	1.000
Sum	9.667	8.333	13.000	3.533	17.000	7.667	7.667

Color Determination

	Datum - Color Sorting	Scorpion	Robot with two arms	Claws and lift kit	Slide system	Spring-based elevator	Stingray
Datum - Color Sorting	1.000	3.000	5.000	1.000	5.000	3.000	1.000
Scorpion	0.333	1.000	1.000	0.200	0.333	1.000	0.333
Robot with two arms	0.200	1.000	1.000	0.333	0.333	0.333	0.200
Claws and lift kit	1.000	5.000	3.000	1.000	3.000	3.000	0.333
Slide system	0.200	3.000	3.000	0.333	1.000	1.000	1.000
Spring-based elevator	0.333	1.000	3.000	0.333	1.000	1.000	1.000
Stingray	1.000	3.000	5.000	3.000	1.000	1.000	1.000
Sum	4.067	17.000	21.000	6.200	11.667	10.333	4.867

End Time Behavior

	Datum - Color Sorting	Scorpion	Robot with two arms	Claws and lift kit	Slide system	Spring-based elevator	Stingray
Datum - Color Sorting	1.000	0.333	0.333	1.000	1.000	3.000	1.000
Scorpion	3.000	1.000	1.000	1.000	0.333	5.000	3.000
Robot with two arms	3.000	1.000	1.000	3.000	1.000	5.000	1.000
Claws and lift kit	1.000	1.000	0.333	1.000	1.000	5.000	0.333
Slide system	1.000	3.000	1.000	1.000	1.000	3.000	1.000
Spring-based elevator	0.333	0.200	0.200	0.200	0.333	1.000	0.333
Stingray	1.000	0.333	1.000	3.000	1.000	3.000	1.000
Sum	10.333	6.867	4.867	10.200	5.667	25.000	7.667

Time to Locate Block in Bin

	Datum - Color Sorting	Scorpion	Robot with two arms	Claws and lift kit	Slide system	Spring-based elevator	Stingray
Datum - Color Sorting	1.000	1.000	0.200	1.000	0.333	1.000	0.333
Scorpion	1.000	1.000	0.333	1.000	0.333	1.000	0.333
Robot with two arms	5.000	3.000	1.000	5.000	3.000	3.000	0.200
Claws and lift kit	1.000	1.000	0.200	1.000	1.000	1.000	0.250
Slide system	3.000	3.000	0.333	1.000	1.000	1.000	0.250
Spring-based elevator	1.000	1.000	0.333	1.000	1.000	1.000	0.250
Stingray	3.000	3.000	5.000	4.000	4.000	4.000	1.000
Sum	15.000	13.000	7.400	14.000	10.667	12.000	2.617

Final AHP Matrix

Final Matrix Transposed						
	Acceleration	Distance from Barrier	Block height (raising and lowering)	Time to Reach Correct Bin (Color Determination)	End Time behavior	Time to locate block within bin
Datum - Color Sorting	0.047	0.091	0.102	0.249	0.106	0.069
Scorpion	0.304	0.284	0.117	0.059	0.199	0.072
Robot with two arms	0.161	0.146	0.091	0.044	0.206	0.238
Claws and lift kit	0.259	0.213	0.318	0.209	0.118	0.074
Slide system	0.061	0.041	0.058	0.116	0.181	0.117
Spring-based elevator	0.116	0.103	0.151	0.104	0.038	0.076
Stingray	0.052	0.123	0.163	0.219	0.153	0.355

Concept Selection



Analytical Hierarchy Process

Concept	Alternative Value
Datum - Color Sorting	0.113
Scorpion	0.133
Robot with two arms	0.152
Claws and lift kit	0.185
Slide system	0.098
Spring-based elevator	0.100
Stingray	0.219

David Bowen

House of Quality

		Engineering Characteristics							
		Units	ft/s ²	in	in	s	s	s,in	s
Customer Requirements	Importance Weight Factor	Acceleration	Distance from Barrier	Block height (raising and lowering)	Time to Reach Correct Bin (Color Determination)	Design/Build Time	End Time behavior	Time to locate block within bin	
Stack Duplo Blocks Correctly	6	1	5	9	9	9	1	5	
Mobility	5	5	9	5	5	9	9	5	
Robot Volume	7	1	5	5	1	1	1	5	
Color Recognition	3	5	1	5	5	5	1	1	
Speed	4	9	1	1	9	9	9	5	
Automatic Shutdown	2	5	1	1	1	1	9	1	
Easy of Implementation	0	5	5	9	5	9	1	5	
Button Pushing	1	1	1	1	1	5	1	1	
Raw Score		97	81	89	85	109	101	69	
Relative Weight %		18%	15%	16%	15%	20%	18%	13%	
Rank Order		3	6	4	5	1	2	7	

David Bowen



Pugh Matrix

Datum		Concepts					
Engineering Characteristics		Scorpion	Robot with two arms	Claws and lift kit	Slide system	Spring-based elevator	Stingray
Acceleration		+	+	+	+	S	+
Distance from Barrier		+	+	+	S	S	S
Block height (raising and lowering)		S	+	S	S	S	+
Time to Reach Correct Bin (Color Determination)		-	-	S	+	-	+
End Time behavior		+	+	+	+	S	S
Design/Build Time		S	-	+	+	-	S
Time to locate block within bin		S	-	S	+	S	+
Sum of Pluses		3	4	4	5	0	4
Sum of Minuses		1	3	0	0	2	0
Rank		4	3	2	1	5	2

Datum		Concepts		
Engineering Characteristics	Scorpion	Stingray	Slide system	Claws and lift kit
Acceleration		S	-	-
Distance from Barrier		-	-	S
Block height (raising and lowering)		+	S	+
Time to Reach Correct Bin (Color Determination)		+	+	+
End Time behavior		-	+	S
Design/Build Time		S	S	+
Time to locate block within bin		+	+	+
Sum of Pluses		3	3	4
Sum of Minuses		2	2	1
Rank		2	2	1

David Bowen



Analytical Hierarchy Process

Concept	Alternative Value
Datum - Color Sorting	0.113
Scorpion	0.153
Robot with two arms	0.139
Claws and lift kit	0.190
Slide system	0.095
Spring-based elevator	0.095
Stingray	0.179

David Bowen

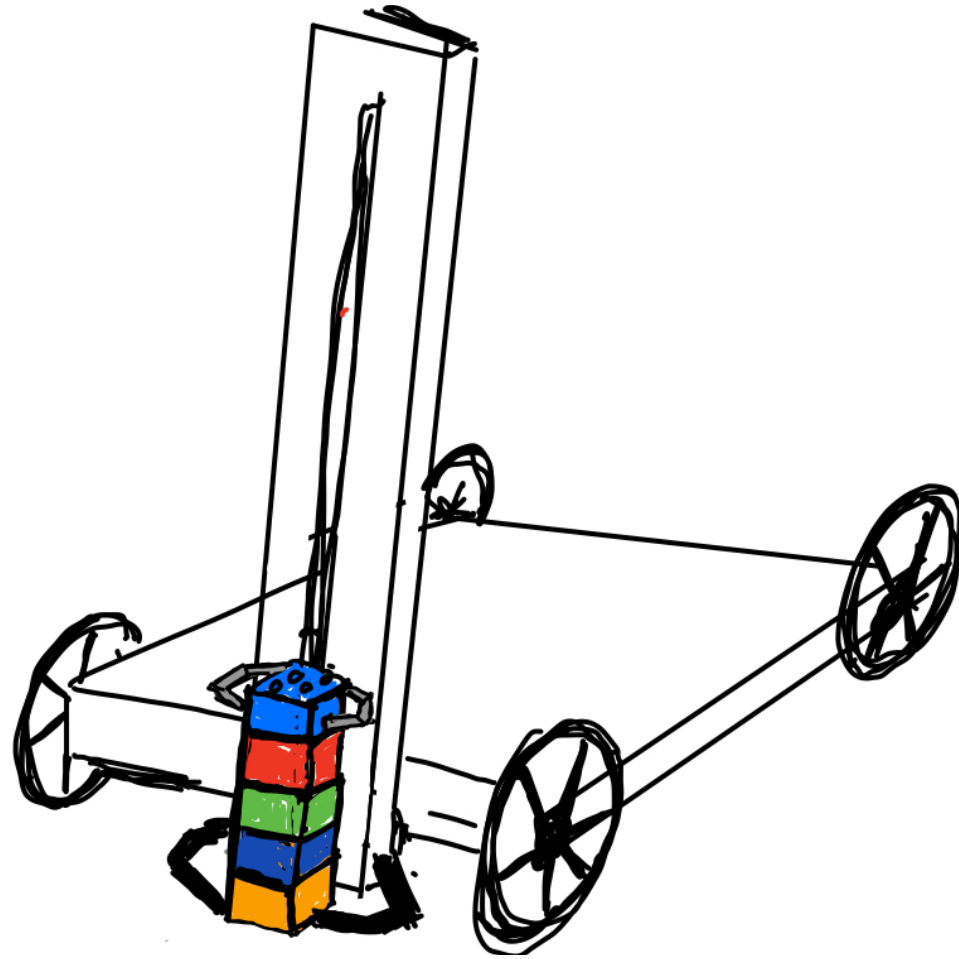

Detailed Math Backup







Standard Shapes

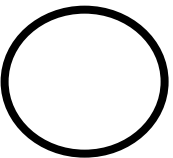
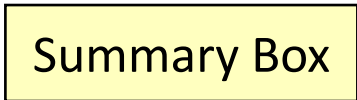
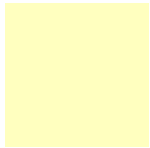

Text box 1

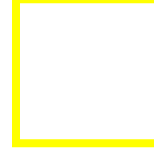
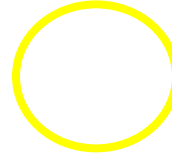
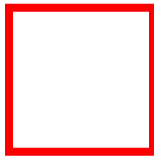
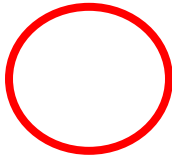

Approved Logos



FAMU-FSU
College of
Engineering



FAMU-FSU
Engineering



FAMU-FSU
Engineering



FAMU-FSU
College of Engineering



Color Palette

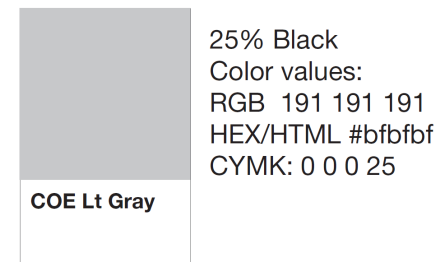
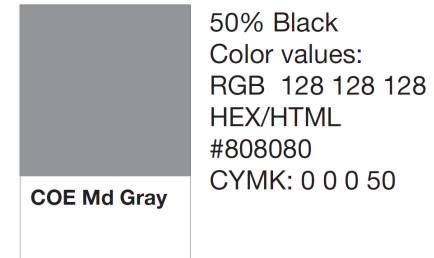
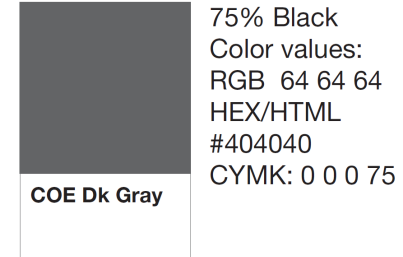
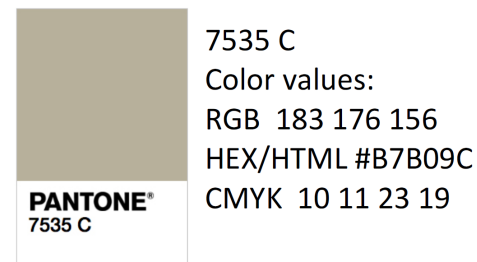
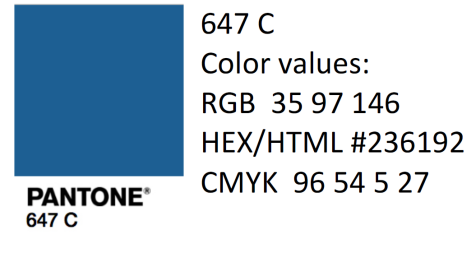
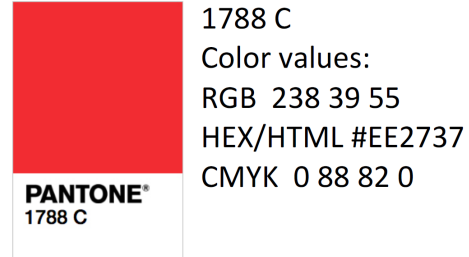
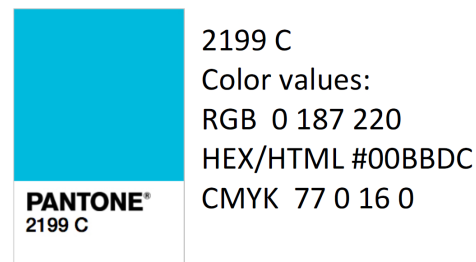
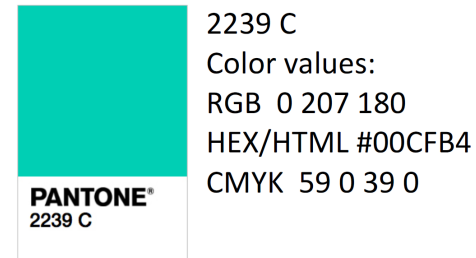
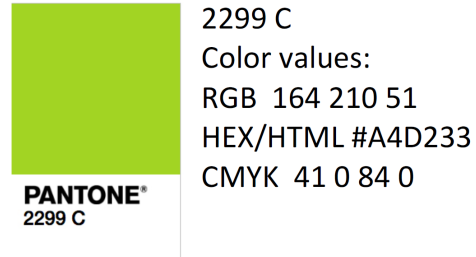

APA Tables

Category 1	Category 2	Category 3	Category 4	Category 5
Item 1				
Item 2				
Item 3				
Item 4				

Category 1	Category 2		Category 3	
	subcategory 1	subcategory 2	subcategory 1	subcategory 2
Item 1				
Item 2				
Item 3				
Item 4				