

Team 517: NASA Sample Manipulation Project

Justin Bomwell, Kalin Burnside, Ryan Dingman, Joshua Jones, Victor Prado, Matthew Schrold

FAMU-FSU College of Engineering

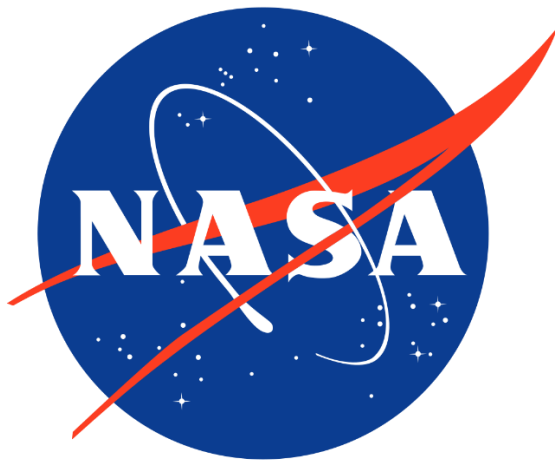

FAMU-FSU
College of
Engineering

Table of Contents

Project Overview..... 2

Mechanical System..... 3

Mechanical Components..... 3

Assembly 4

Operation 7

Trouble Shooting..... 8

Electronics 9

Electrical Components..... 9

Assembly 10

Operation 12

Trouble Shooting..... 12

Project Overview

The goal of this project is to provide a way for NASA to conduct an initial analysis of Martian rocks while on Mars to determine if the rocks may be worth bringing back to Earth to study for signs of life. Our system has 3 main functions: collect the sample, orient the sample for sensors, and store the sample. The primary focus of the project is on collection and orientation, as that is where we felt we could provide the most innovation. The orientation part of our project is centered around the end-effector, a mechanism on the end of a robotic arm which will pick up and orient the sample rocks. The end-effector consists of 2 perpendicular pairs of “fingers” which translate in and out (to grip the sample) and rotate (to orient the sample). We’ll be providing the most detailed design as well as physical prototype for the end-effector, but we will also be creating models and simulations for the robotic arm and potential storage system. The robotic arm would move the end-effector from the sample pick-up location to sensor locations to storage. Storage would have to prevent the samples from being destroyed during transit from Mars to Earth as well as prevent any possible cross contamination. Our new design will provide a robust system for scanning the full surface of items which may prove useful for purposes other than a Mars mission.

Mechanical System

The operation and troubleshooting of the mechanical parts should only be conducted by someone with expertise in such a field. Lack of competency may result in the personal injury or in damage of parts.

Mechanical Components

Roller Chain Sprocket: The roller chain sprocket is used to transfer mechanical power from the upper housing unit to move the fingers.

Square Face DC Motor: The square face DC motors are used to drive finger movement to grasp samples.

Position-Control DC Motor: The position-control DC motors are used to provide precise rotation of the fingertips.

Carbon Steel Keyed Rotary Shaft: The shafts are used throughout the device to transfer rotation from the motors to power the translation and rotation of the fingers.

Metal Miter Gear: The metal miter gear is used to couple two parallel fingers by being powered through one square face DC motor.

Metal Gear: The metal gear is used to convert rotational power from the DC motors to translational movement when used in conjunction with a gear rack.

Metal Gear Rack: The metal gear rack is used to convert rotational power from the DC motors to translational movement when used in conjunction with a metal gear.

Roller Chain: Roller chains are utilized to transfer mechanical power generated in the upper section of the end effector to the fingers.

Machinable-Bore Clamping Steel Shaft Coupling: Couples the position-control DC motor to the rotary shafts to provide rotation of the fingertips.

Ball bearings: Ball bearings are used throughout the device to support the rotary shafts while reducing undesired friction.

Assembly

All mechanical components will be housed in an outer shell. At the center of the shell is the shell core (*fig. 1 left*). The shell core will have the DC motors (*fig. 1 right*), and the drive shafts (*fig. 2*) mounted to it. Once the DC motors are mounted, a single miter gear will be attached to the shaft of each. The outer diameter of the shaft matches the inner diameter of the miter gear, so no adapter is needed. The chains connecting sprockets are shown in yellow in all figures.

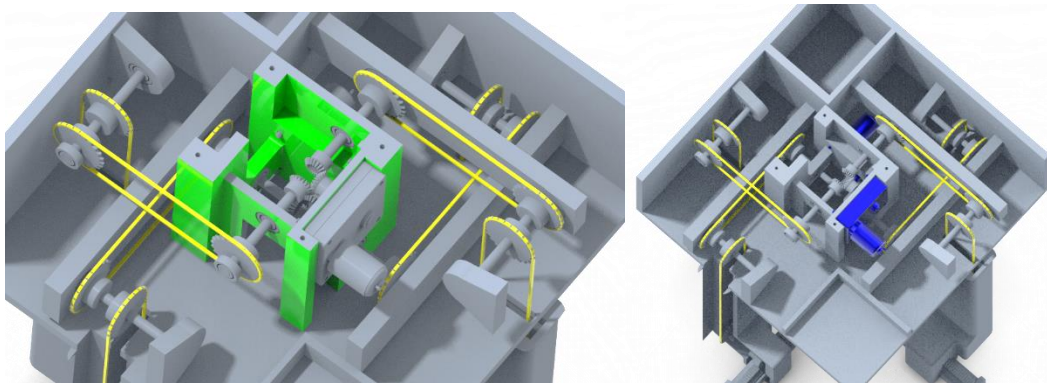

Figure 1 left: Shell Core (green) right: DC motor placement (blue)

The drive shafts are 93.8 mm long and use 2 bearings, 1 sprocket, and 1 miter gear, spaced as shown. The miter gear will contact the gear attached to the motor, while the sprocket

will drive a chain to the next shaft. The miter gear of each drive shaft will be 90° offset from the motor gear, and the two drive shafts connected to the DC motor will be 180° from each other.

Both bearings of each drive shaft will be supported by the core of the shell.

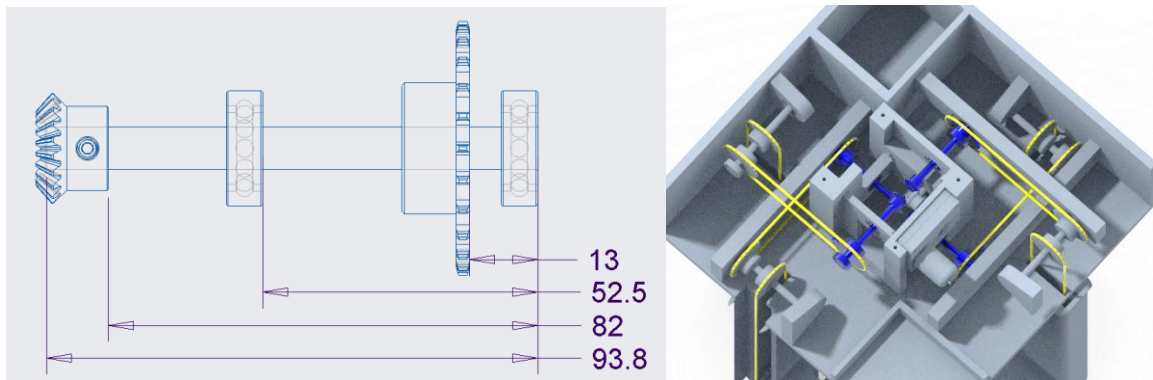

Figure 2 left: Drive shaft drawing (all dimensions in mm) right: Drive shaft placement in shell (blue)

The chain driven by the drive shaft will be connected to the turn shaft. The purpose of the turn shaft is to change the direction of power transmission by 90° , transferring the power from the DC motor down to the fingers. The shaft is 97.8 mm long with two bearings (one fitted onto each end of the shaft), and two sprockets. The sprocket closer to the end of the shaft will connect to the drive shaft, while the sprocket closer to the middle of the shaft will connect to the knuckle shaft.

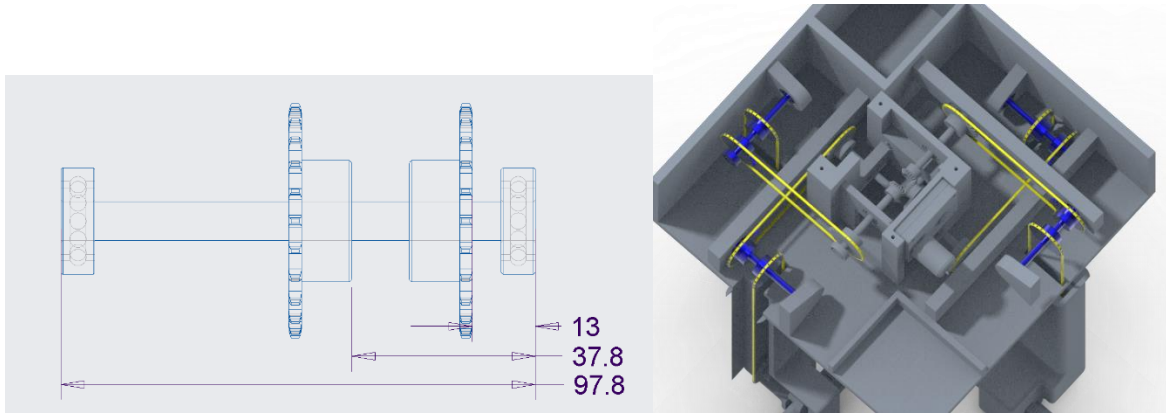

Figure 3 left: Turn shaft drawing (all dimensions in mm) right: Turn shaft placement in shell (blue)

The knuckle shafts are located at the base of each finger branch. They are 89 mm long and use 2 bearings, 1 sprocket, and 1 pinion. The pinion will connect to the rack on the fingers, allowing for translational motion. Since opposite fingers are driven by the same motor, and the miter gears for each drive shaft are 180 degrees opposite, opposing knuckle shafts will counter rotate and both fingers will be driven inward, or outward, simultaneously.

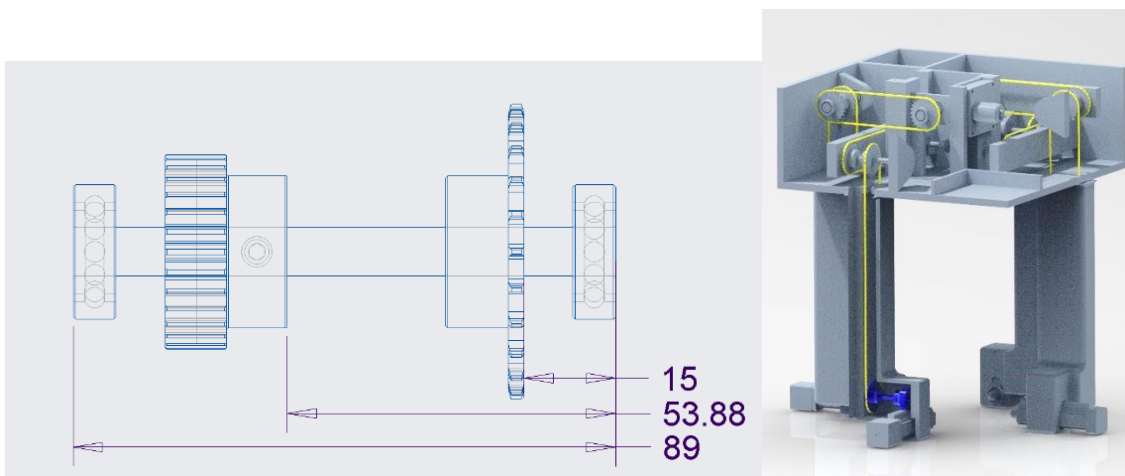

Figure 4 left: Knuckle shaft drawing (all dimensions in mm) right: Knuckle shaft placement (blue)

The finger shaft uses 2 bearings, and a silicon fingertip. In a set of opposing fingers, one will have a stepper motor (*fig. 5 right, red*) attached, while one will have a simple backing (*fig. 5 right, green*) attached. There are four 3 mm screw holes which either the motor or the backing can be secured with. Each finger with a motor will require a coupler (shown in *fig. 5 left*) which will couple the stepper motor output shaft and the rotating shaft for the finger. Once the fingertips are in full contact with the sample during operation, the rotation of the unactuated finger will be driven by the opposite actuated finger. Each finger will have a rack mounted to the top to drive translational motion generated by the pinion on the knuckle shaft.

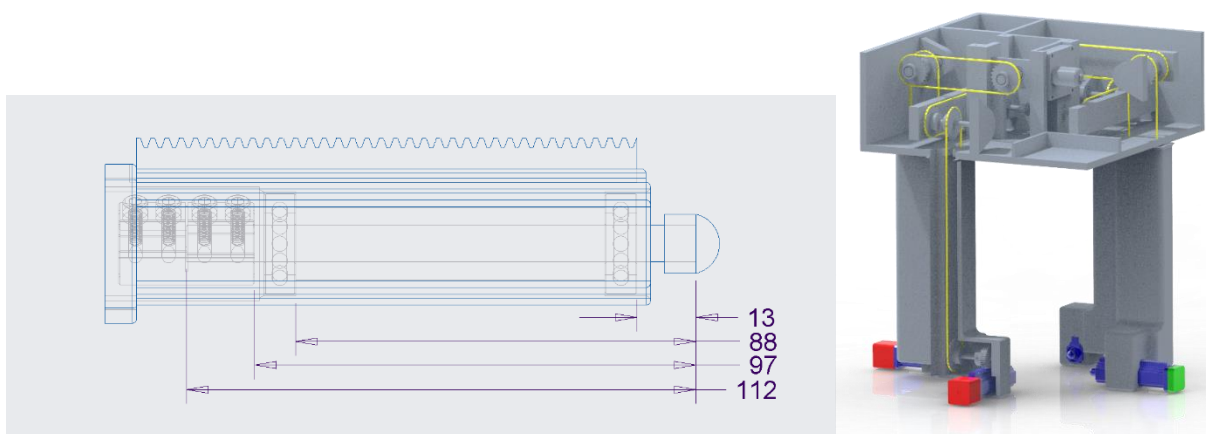

Figure 5 left: Finger drawing (all dimensions in mm) right: Finger and attachment placement (motor – red, backing – green)

Operation

1. Input location coordinates of the desired object.
2. Wait for the object to be moved onboard to where the sensors will be operated.
3. Once the object is aligned properly, input desired locations on the object to have that point on the object aligned in front of the sensors.

4. Repeat step 3 until all desired points of interest on the object have been accessed by the sensors.
5. Once step 4 is completed, choose to move the sample to storage (Step 5.a) or to discard the sample back to the environment (Step 5.b).
 - a. Choose a storage bin to store and secure the sample during transport.
 - b. Wait for the arm to return the sample to the environment.
6. Repeat steps 1-5.

Trouble Shooting

1. If **fingers are not translating at equal rates**, ensure that the chains are tensioned properly by adding or removing chain links so that the chain is wrapped tightly around the sprockets.
2. If there is **difficulty assembling the fingers**, first connect the motor shaft to the rotation shaft with the coupler then attach the inner bearing to its correct position. Then attach the motor to the fingers with the mounting screws. Finally, secure the outer bearing using a rubber mallet and a socket that is the same diameter as the bearing.
3. If there are **issues securing an object with the fingers**, make sure that the silicone tips on the fingers are attached properly so that they do not move with contact.
4. If the **finger shaft is not turning when the stepper motor is active**, disassemble the finger set and check the connection between the shafts and the coupler. Since the coupler inner diameter on the motor side is larger than the motor output shaft, the shaft diameter extension (accomplished with duct tape in the prototype) may need to be replaced.

Electronics

The operation and troubleshooting of the electronics should only be conducted by someone with expertise in such a field. Connecting parts in ways that they are not meant to be connected could result in damaged parts, fires, and even electrocution.

Electrical Components

Arduino Uno R3: The Arduino Uno R3 is used to send signals to the motor drivers for operation. These units operate between 7 V and 12 V with a maximum current draw of 40mA.

Tic T500 Stepper Motor Controller: The stepper motor controller is used to drive both stepper motors and can operate between 4.5 V and 35 V, but they can only deliver up to 1.5 A per phase without proper cooling. It can be communicated with using I2C, USB, and non-inverted TTL serial.

Dual Serial Motor Controller: The DC motor driver operates between 6 V and 16 V with a maximum of 30 A. It can be communicated with using non-inverted TTL serial.

Jumper Wire (M-M/F-F): The jumper wires are used for connecting the microcontroller with the drivers as well as the motors if need be.

Insulated 9V Battery Snap Connectors: The 9v battery snap connectors will be used to power the microcontrollers.

16 AWG Wire Black: The 16 AWG wire black will be used to make connections to the negative terminal of the lead acid battery and the rest of the system.

16 AWG Wire Red: The 16 AWG wire red will be used to make connections to the positive terminal of the lead acid battery and the rest of the system.

In-line Fuse Holder: The in-line fuse holder will be placed in series with the positive terminal of the battery for safety precautions.

Fuse 5A: The 5 A fuse will be placed inside the in-line fuse holder to limit the maximum current our system will draw to 5 A.

12VDC Lead Acid Battery 18Ah: The 12 VDC Lead Acid Battery will power our drivers and motors. This battery must be handled with care due to its max short-duration discharge current (10 sec) of 18 A

Procell 9v Alkaline Battery: These batteries will be used to power the Arduino's.

Electrical Tape: The electrical tape will be used to tape off exposed leads and wires that could potentially be shorted or touched unintentionally.

Extra Components from Dr. Hooker: Barrel connector for 9v battery snap connectors to plug into Arduino, and a L289 motor driver for the DC motors for a backup.

Assembly

First the motors must be connected to their respective motor drivers. The two stepper motors will be attached to the Tic T500 controllers by soldering the wires to the output terminals on the driver. Jumper wires or the AWG 16 wires may be used to extend the wires from the motors to accomplish this. The same will be done for the DC motors, but both connected to the Dual serial motor controller on output ports one and two.

The Arduino may be connected to the motor driver's communication ports via jumper wires. The insulated 9v battery snap connectors can be attached to the barrel port terminals and

connected to the Arduino. When the Arduino needs to be used a 9v battery can be attached to the snap connectors to power it.

The motor drivers must be connected in parallel to each other and the battery to operate off the same voltage. The connections to the 12VDC lead acid battery will be made last. The 16 AWG red wire needs to be connected to the positive input terminals of the drivers, and the 16 AWG black wire to the negative input terminals of the same drivers. The in-line fuse holder will be connected between the battery and the node that connects each driver in parallel using the 16 AWG red wire. The 5 A fuse must be placed inside the in-line fuse holder before connecting the battery. Finally, connect the in-line fuse holder to the positive terminal of the lead acid battery and the 16 AWG black wire from the negative input terminals of the drivers to the negative terminal of the battery.

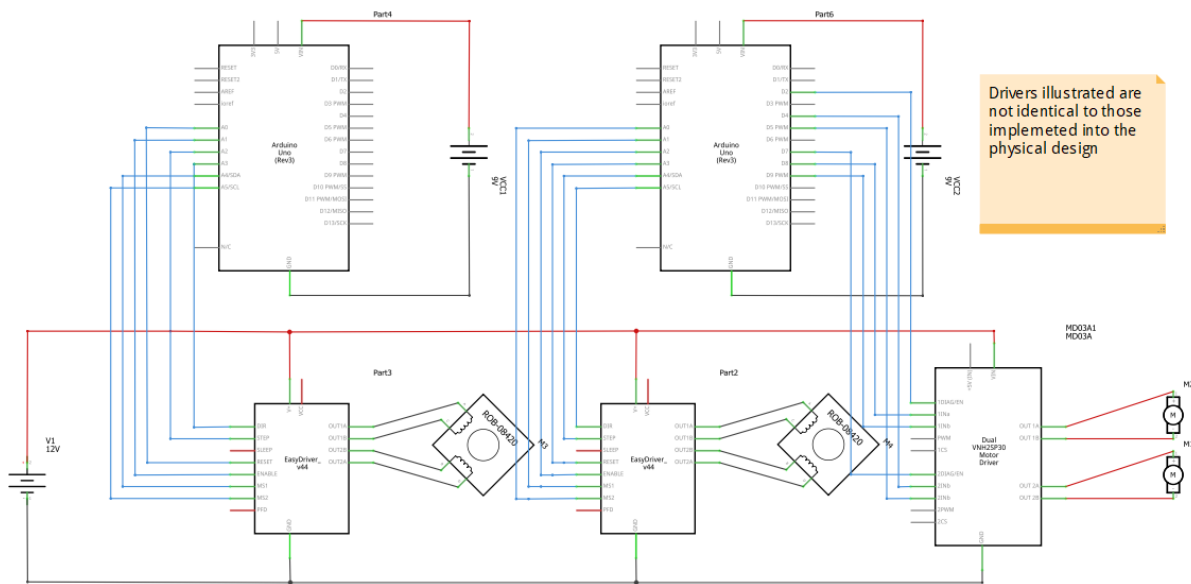

Figure 6: Wiring diagram for Electronics

Operation

Once the electronic components are assembled the system is ready to go. The Arduino unit can be programmed to send instructions to the motor drivers using the non-inverted TTL serial or I2C communication protocol covered in the software portion of this manual.

Trouble Shooting

If the power lights on any of the drivers are out, then power is not being supplied and a few things could have gone wrong.

1. **Before attempting to troubleshoot**, check the leads to the battery to make sure its properly connected and has contact with the live and ground wires.
2. If the battery is connected properly, disconnect the battery and check to make sure it has a charge.
3. Leave the battery disconnected and check the in-line fuse to see if the 5 A fuse has been blown. If the fuse has been blown replace it with a new 5 A fuse.
4. Check the connected points between the drivers and the battery to see if they are making proper contact.
5. If all previous steps have been followed and the problem persists the drivers could have been damaged and may need to be replaced. Individually testing the drivers outside of the system could give more information on why they do not work.

If the Arduino R3 units are not lighting up:

1. Check the Insulated 9v battery snap connectors to make sure they're connected
2. Make sure the 9v battery has charge

3. Make sure the connections from the battery snap connector to the barrel port adapter are connected properly.

If all drivers and Arduino units are powered up but motors will not run:

1. Confirm that the connections between the motor and their respective drivers are made and secure.
2. Use a multimeter to measure the current being drawn to the motor and the voltage referenced to ground. If the motor isn't receiving a voltage it could be a software issue or if it is but not as much as expected the motor could have been damaged and will need replacing.