

Team 508
SAE Aero Design:
Geometric Integration
EML 4552C

Team Members

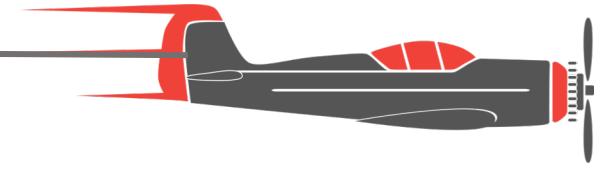

Jacob Pifer
Project Manager
Manufacturing Engineer



Lauren Chin
Lift & Control Surfaces Engineer
Meeting Coordinator
CAD Engineer



Joseph Figari
Fuselage and Payload Engineer
Financial Coordinator
CAD Engineer

Sponsors

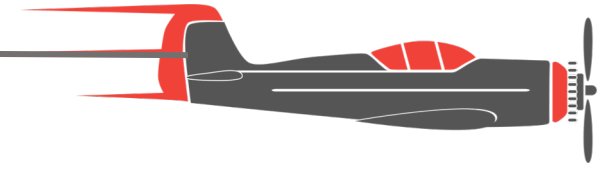

Florida Space Grant Consortium
Financial Sponsor



Seminole RC Club
Equipment Provider



Shayne McConomy, PhD
Faculty Sponsor

Jacob Pifer

Advisors

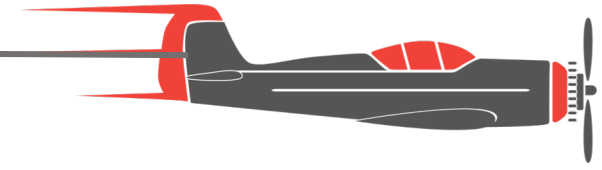

Simone Hruda, PhD
Faculty Advisor



Eric Adams
Fablab Supervisor



Dorr Campbell, PhD
Materials Advisor

Jacob Pifer

Project Objective

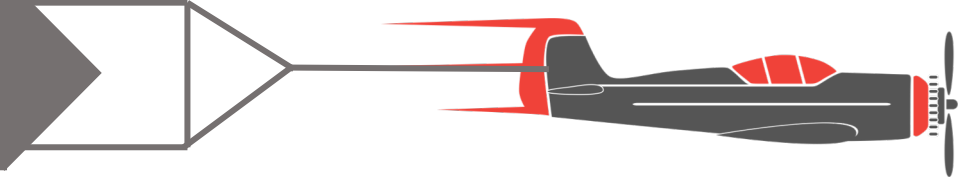

- The objective of this project is to design and manufacture a 3D printed remote control airplane within the rules of the SAE Aero Design Competition
- It will be able to take off, complete the needed flight path, and land while carrying the required cargo



Jacob Pifer

Project Brief Summary

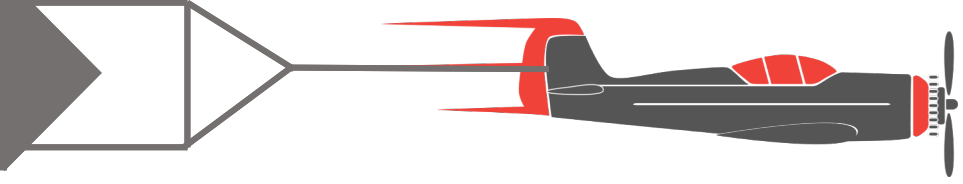

- The plane will not be flown at the competition in March
- Team is still a part of the competition
- Plane will still be built within competition rules
- Test flight will be done in Tallahassee with Seminole RC Club
- If necessary and time permits, design changes will be made and a second flight will take place

Jacob Pifer

Project Brief Summary

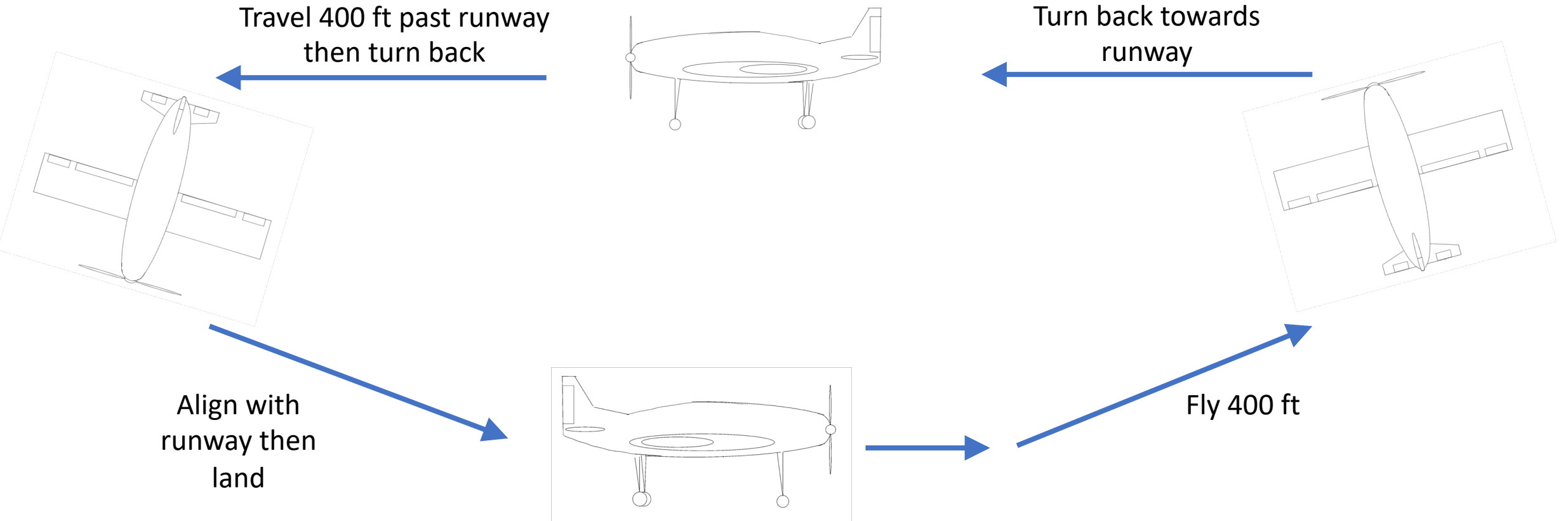
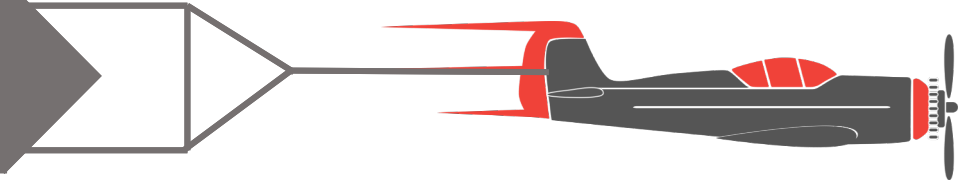

Jacob Pifer

Material Selection

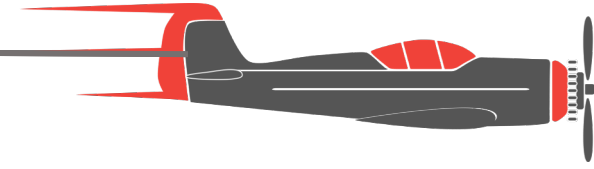

- House of Quality found weight to be most important design factor
- Two possible filaments could be used within budget and competition rules
 - PLA
 - LW-PLA
- Torsion and bending tests done to compare strengths
- Tests found PLA to be stronger but due to weight advantage LW-PLA was chosen



Jacob Pifer

Printers

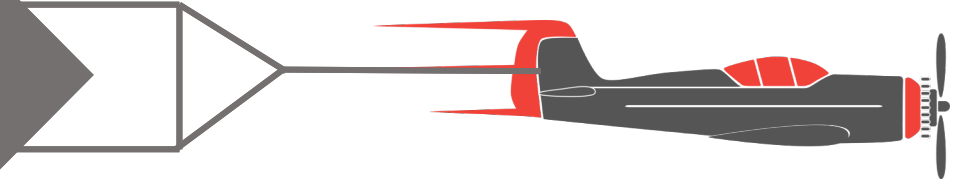

- Lulzbot TAZ printers are the main printers used
 - Design Lab has two and the Innovation Hub has one
- Any PLA parts will be printed at the Innovation Hub
 - Small parts that DREMEL printers can make
- Cura-lulzbot used to queue prints
 - Helps in estimating print time, material used, and needed printing orientations

Jacob Pifer

Printing Parts

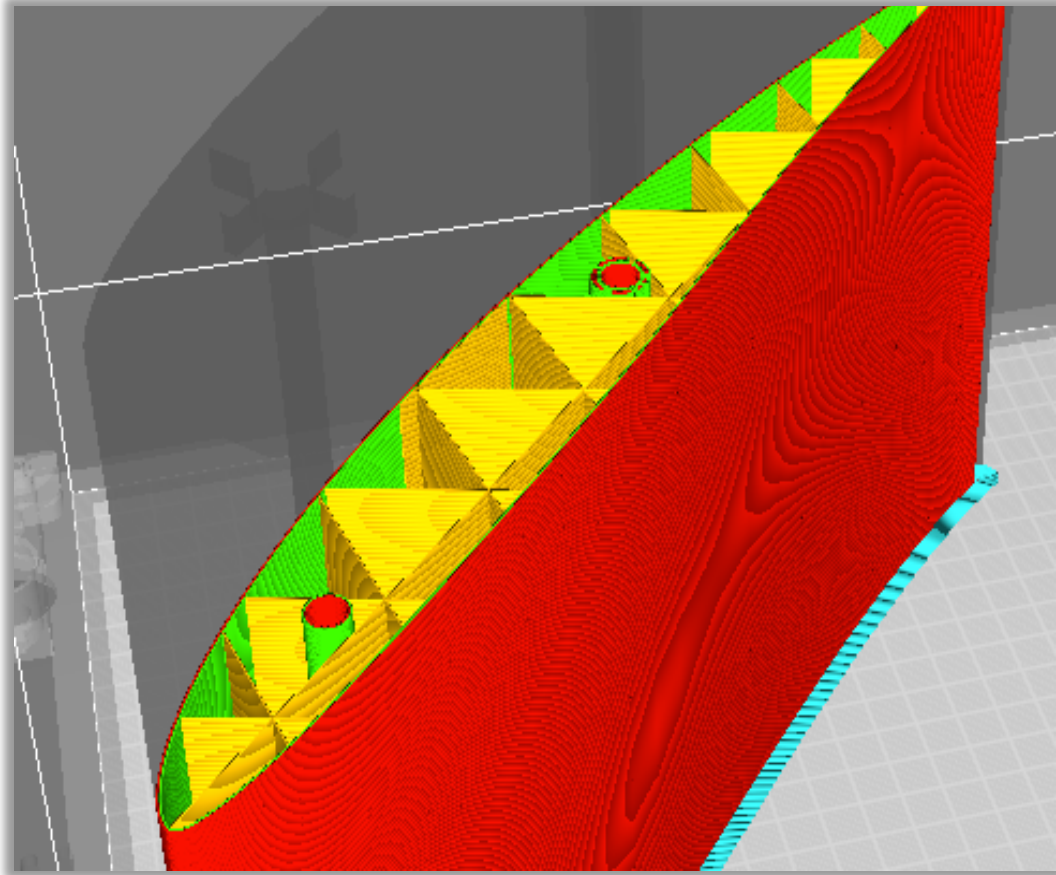
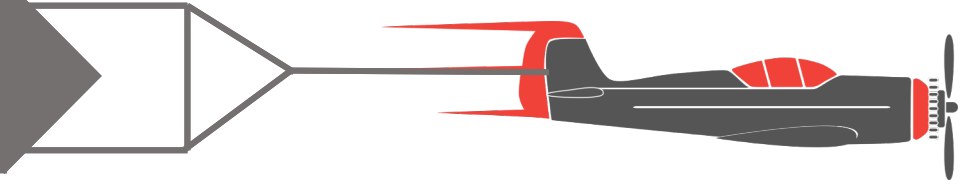

Jacob Pifer

Printing Parts

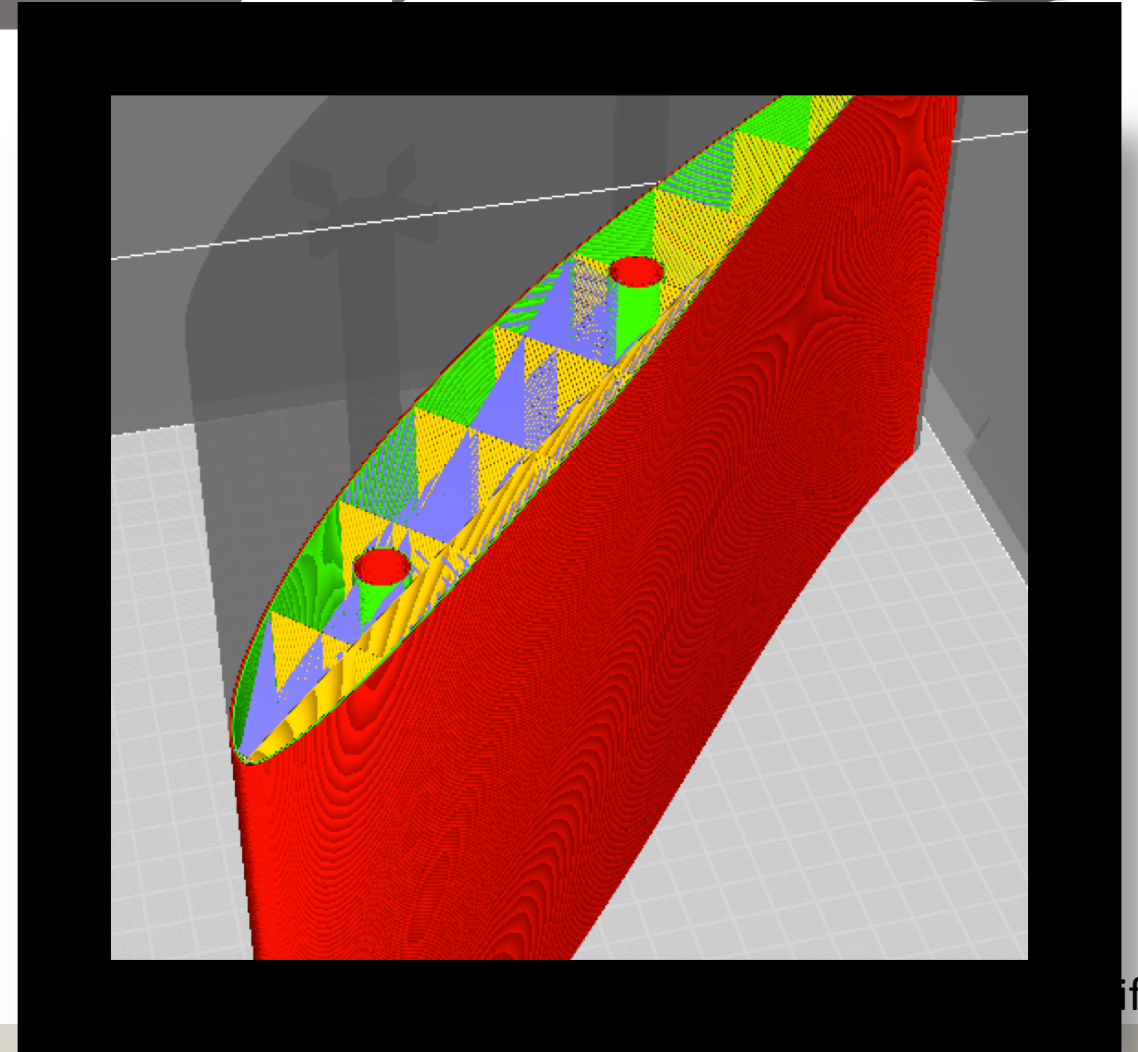
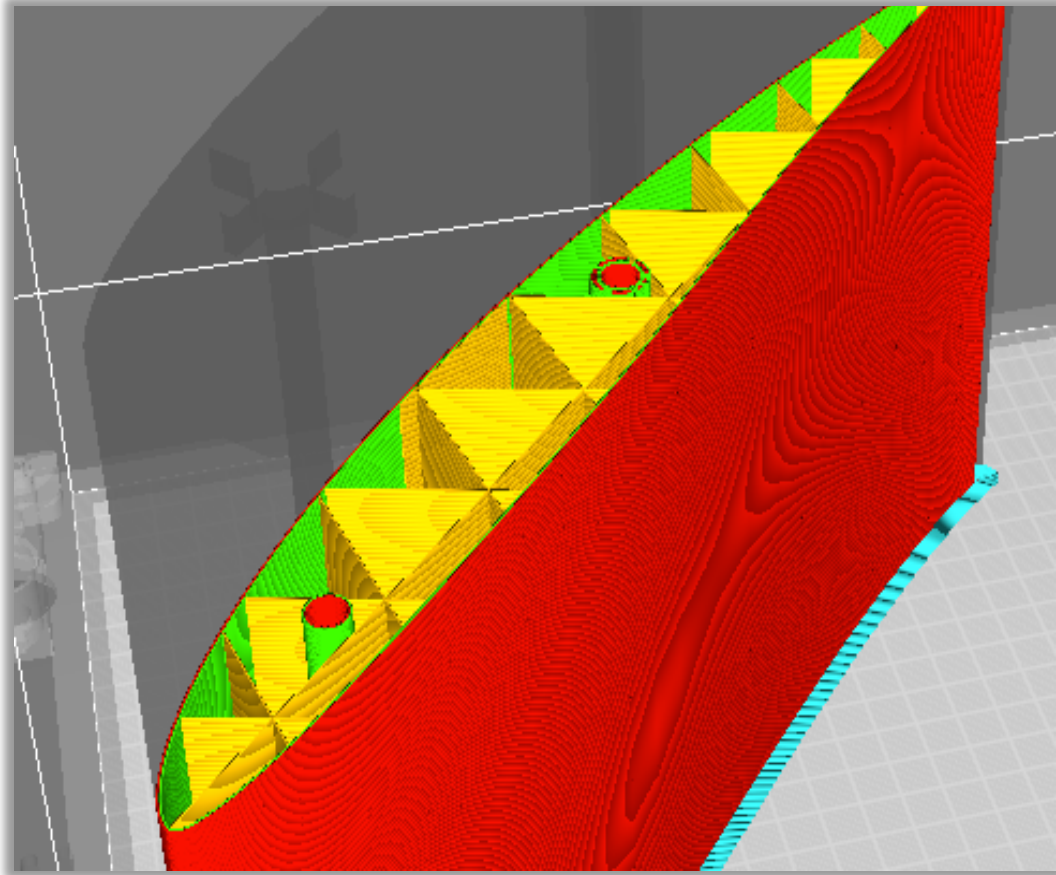
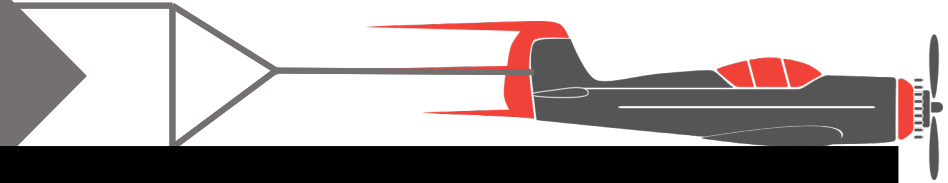

Canard Dimensions

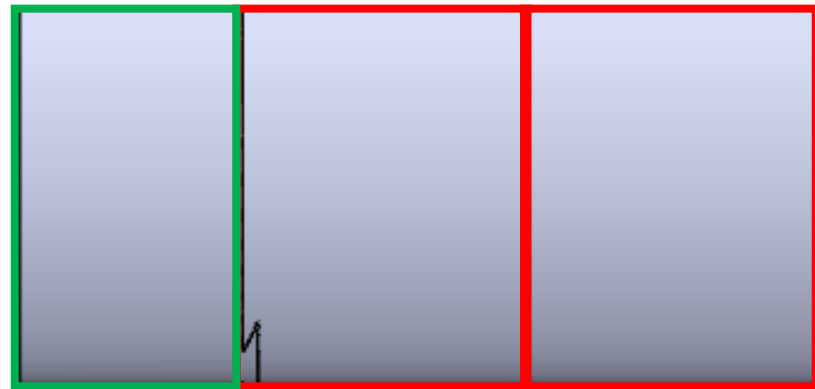
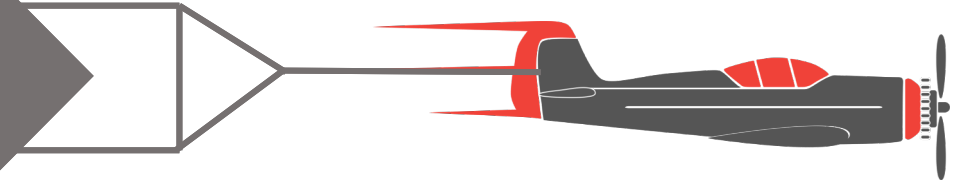

24.5"

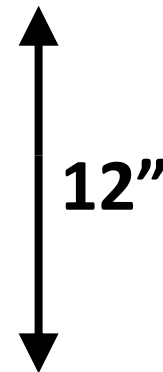

12"

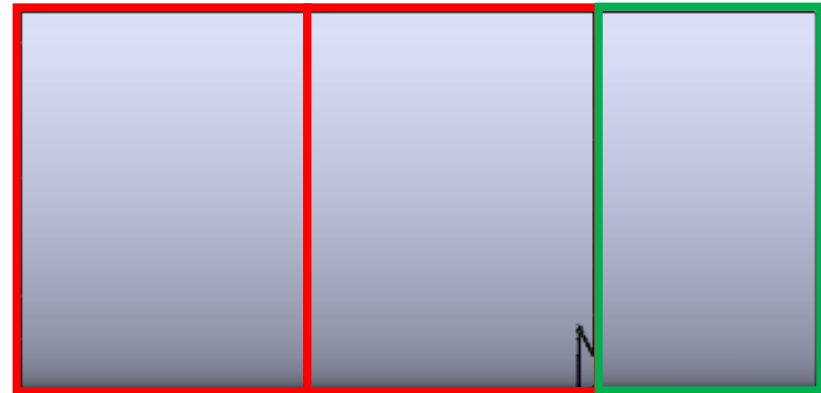

24.5"

Jacob Pifer

Project Brief Summary

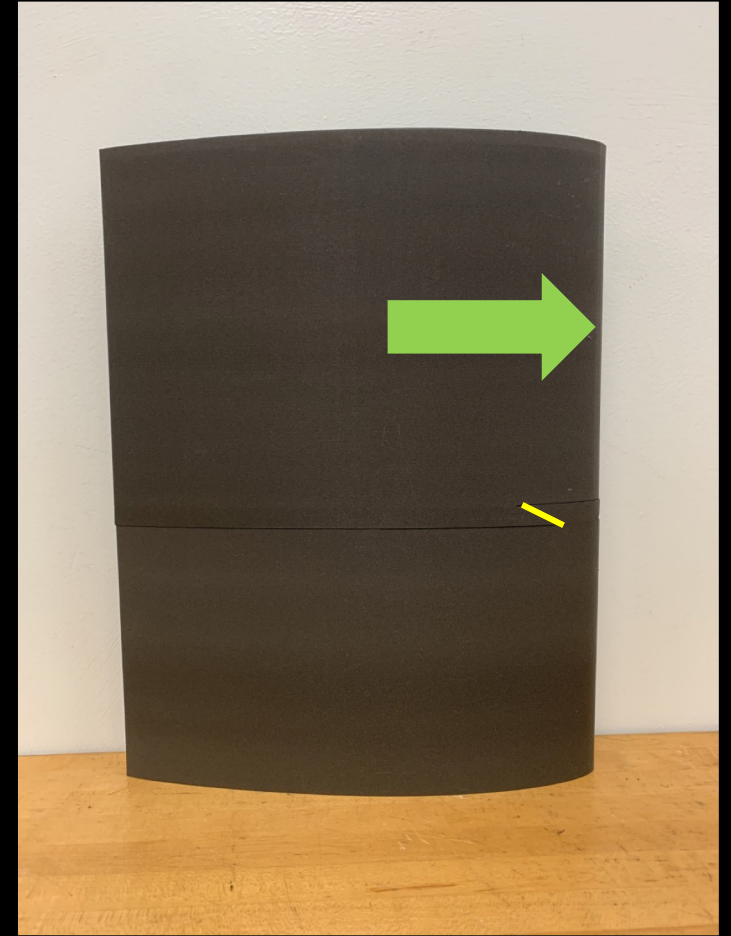
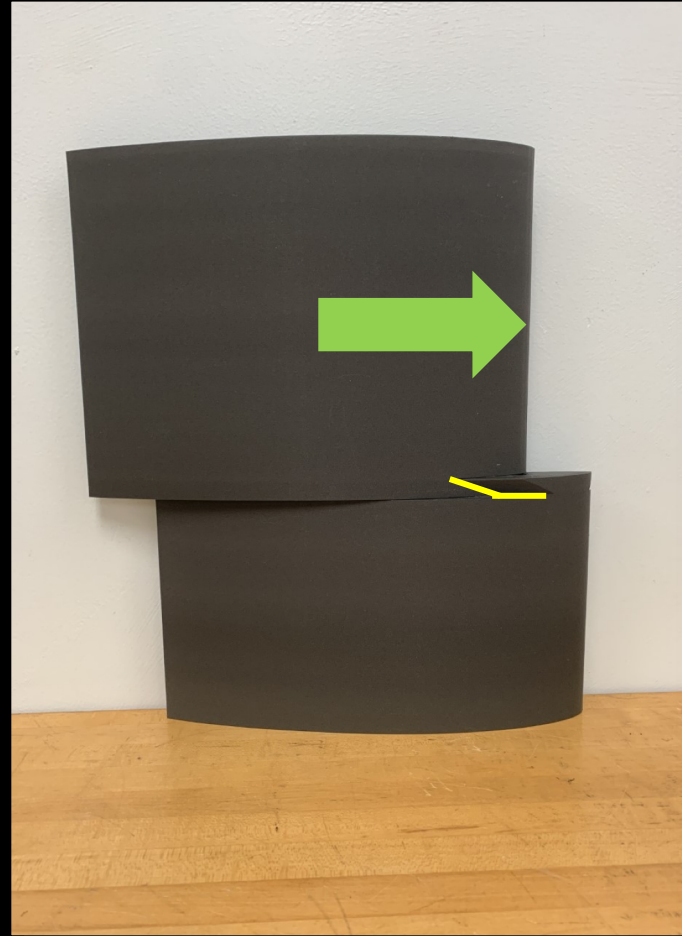
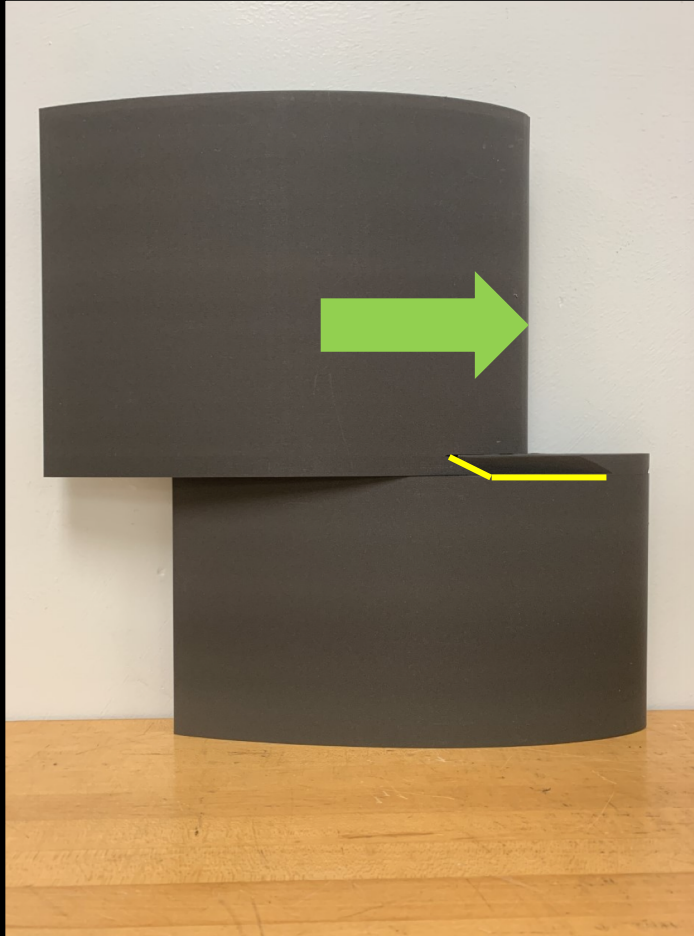
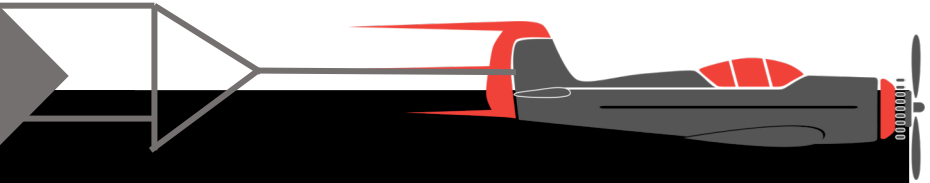

Fuselage Discussion

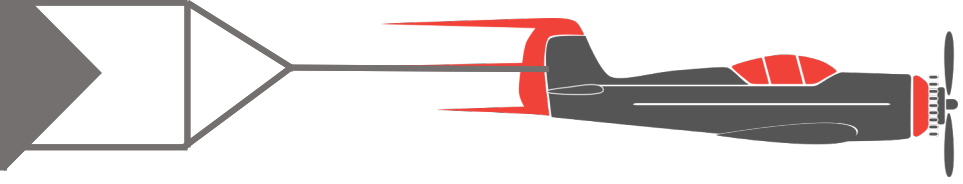

- Body of the fuselage
- Tail of the plane
- Canards of the plane
- Landing Gear

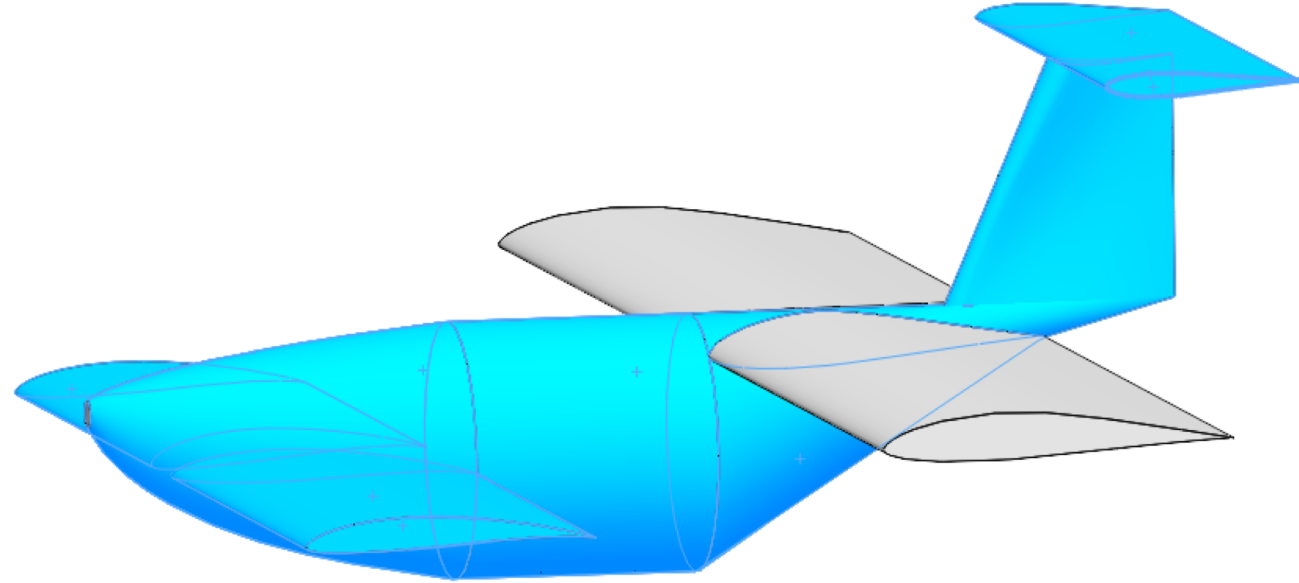

Joseph Figari

Fuselage Redesigned

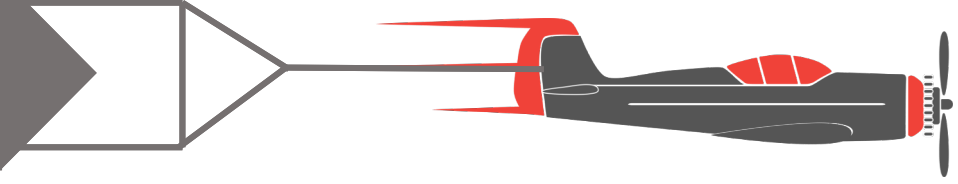

- Due to a wrong density value in our original CAD, we had to redesign our plane
- Plane came out 14 pounds heavier than expected
- Weight was cut by reducing the length of fuselage and reducing the size of the tail

Joseph Figari

Fuselage Redesigned

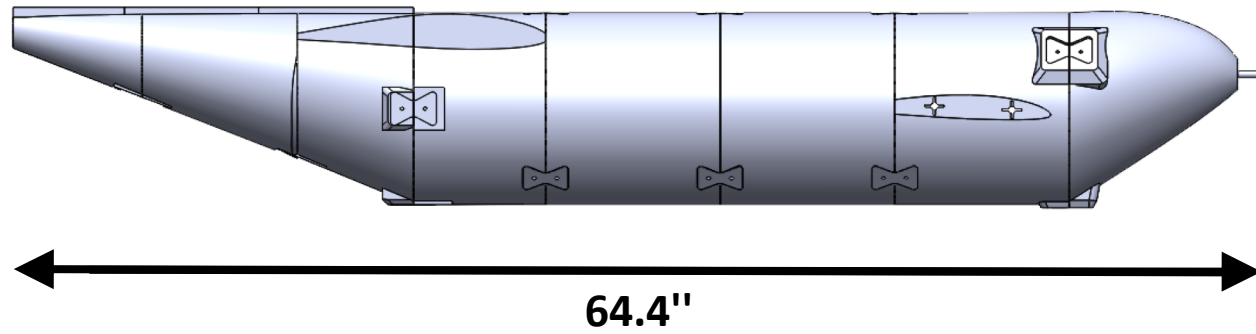
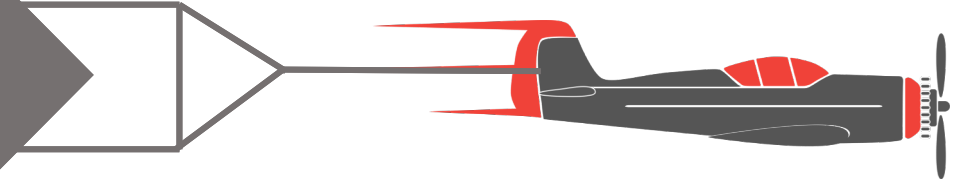

Joseph Figari

Fuselage Redesigned

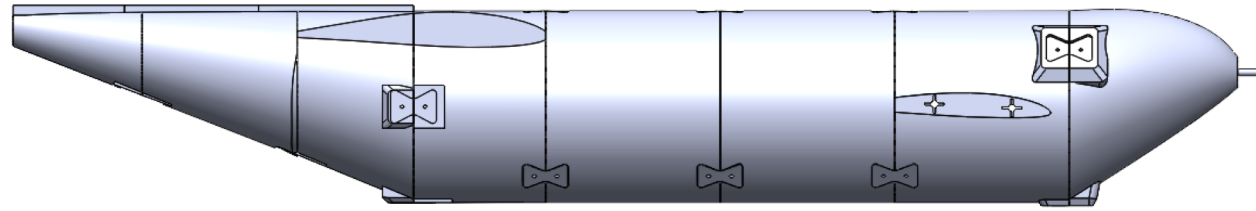
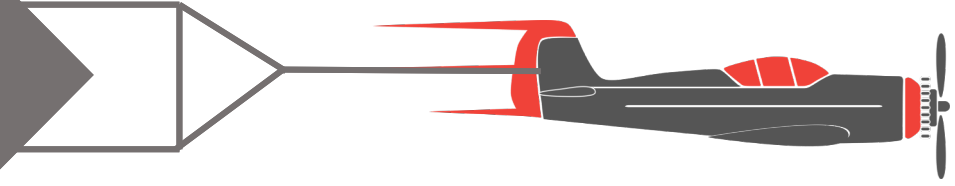

64.4"

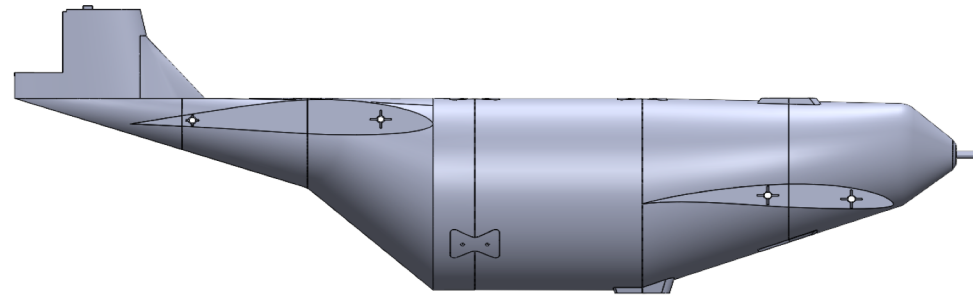

45"

Joseph Figari

Fuselage Redesigned

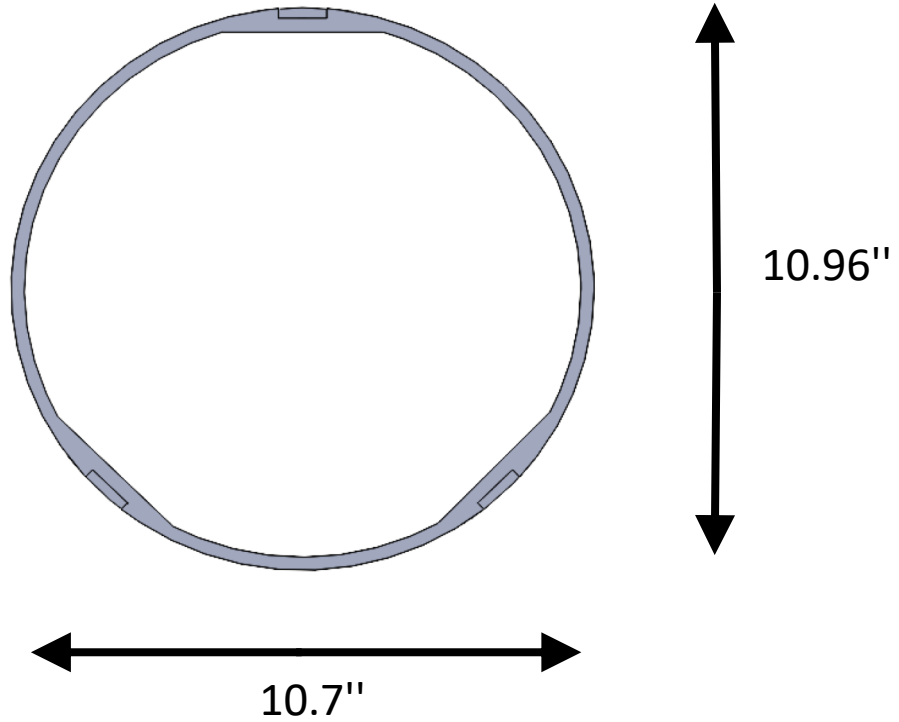
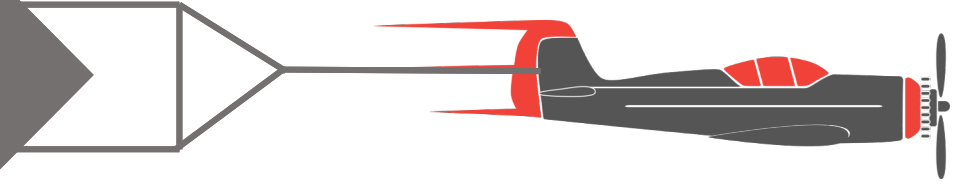

Joseph Figari

Fuselage Redesigned

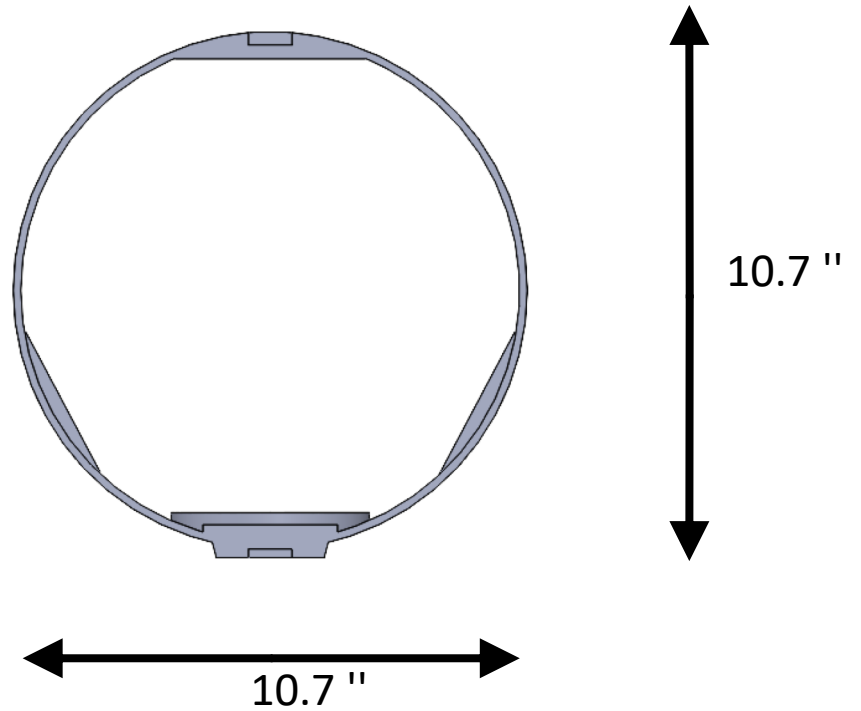
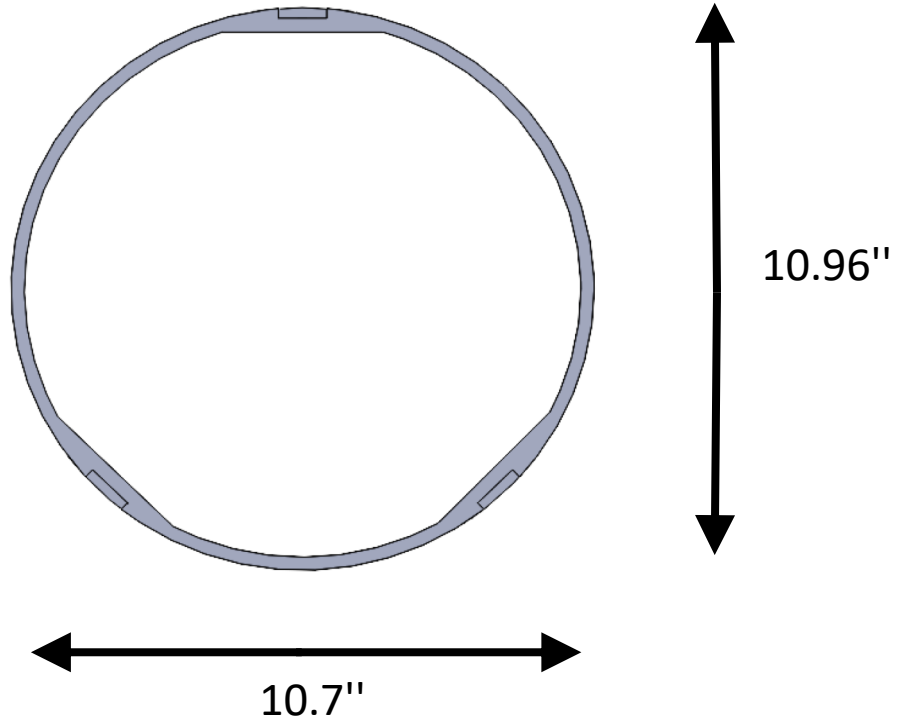
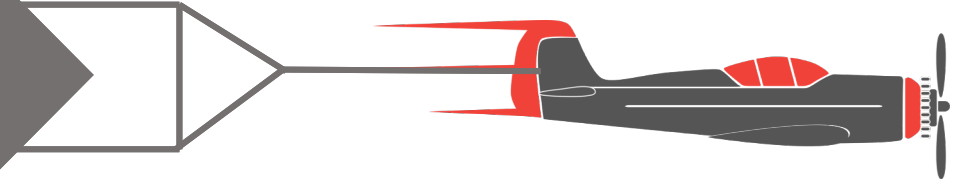

Joseph Figari

Landing Gear

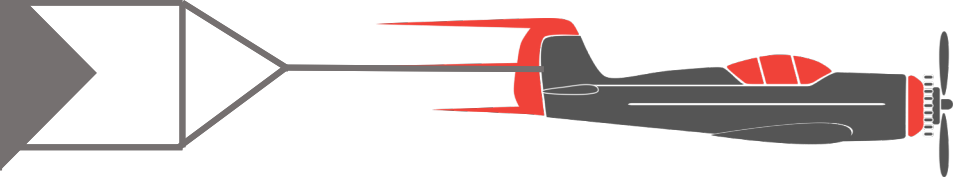

- Seminole RC gave recommendations on designing the landing gear
- Back wheels should be set 20 inches apart
- Propellor should have a 2 – 5 inch ground clearance
- This will help in stabilizing the plane during take-off

Joseph Figari

Landing Gear

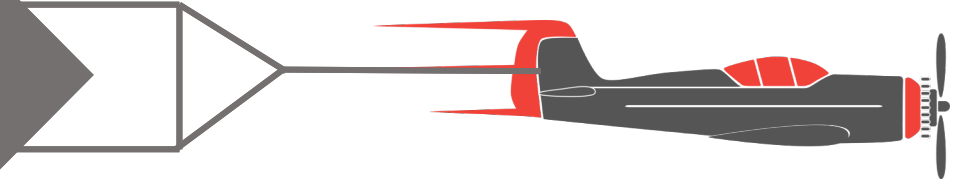

Joseph Figari

Landing Gear

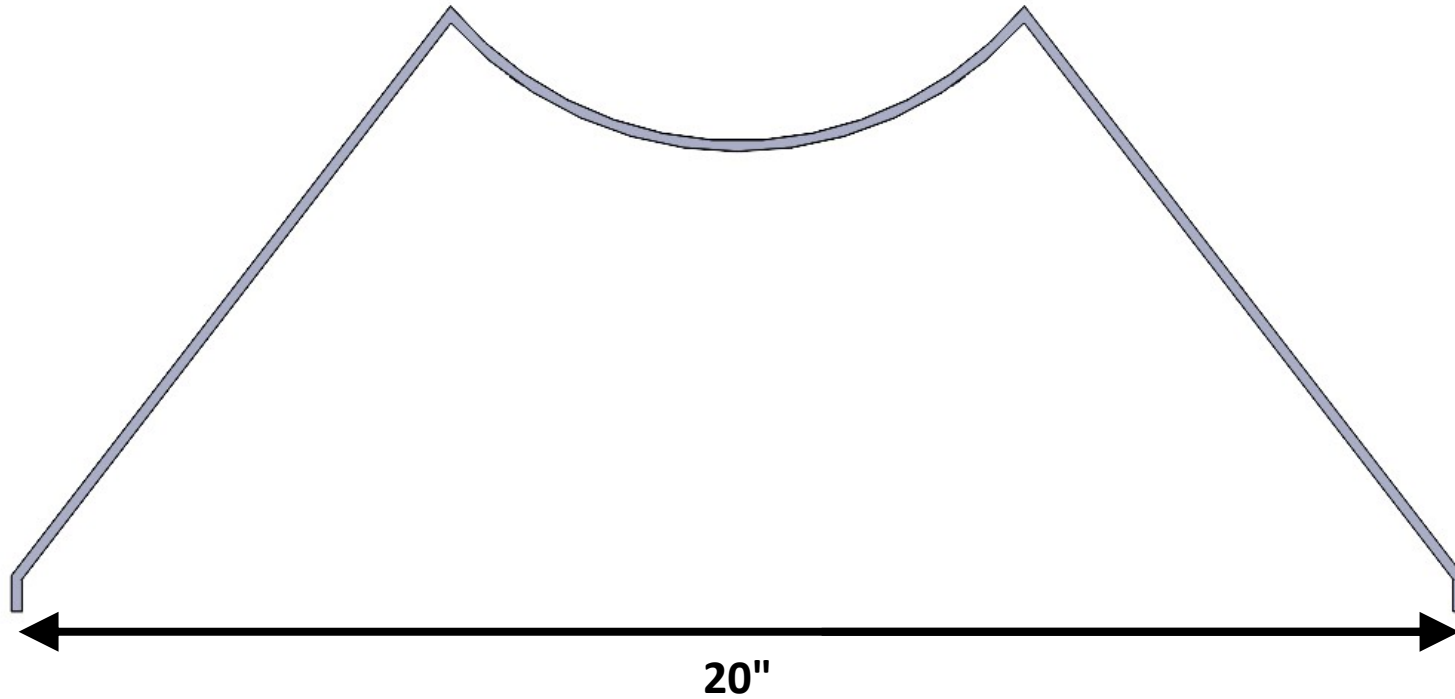
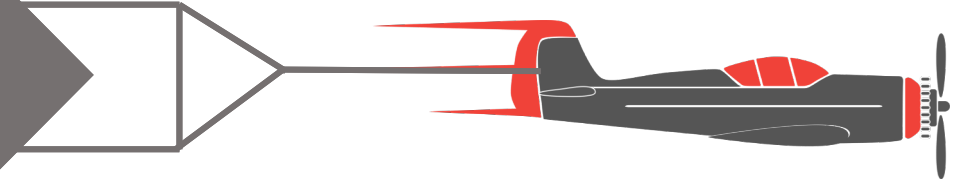

Joseph Figari

Landing Gear

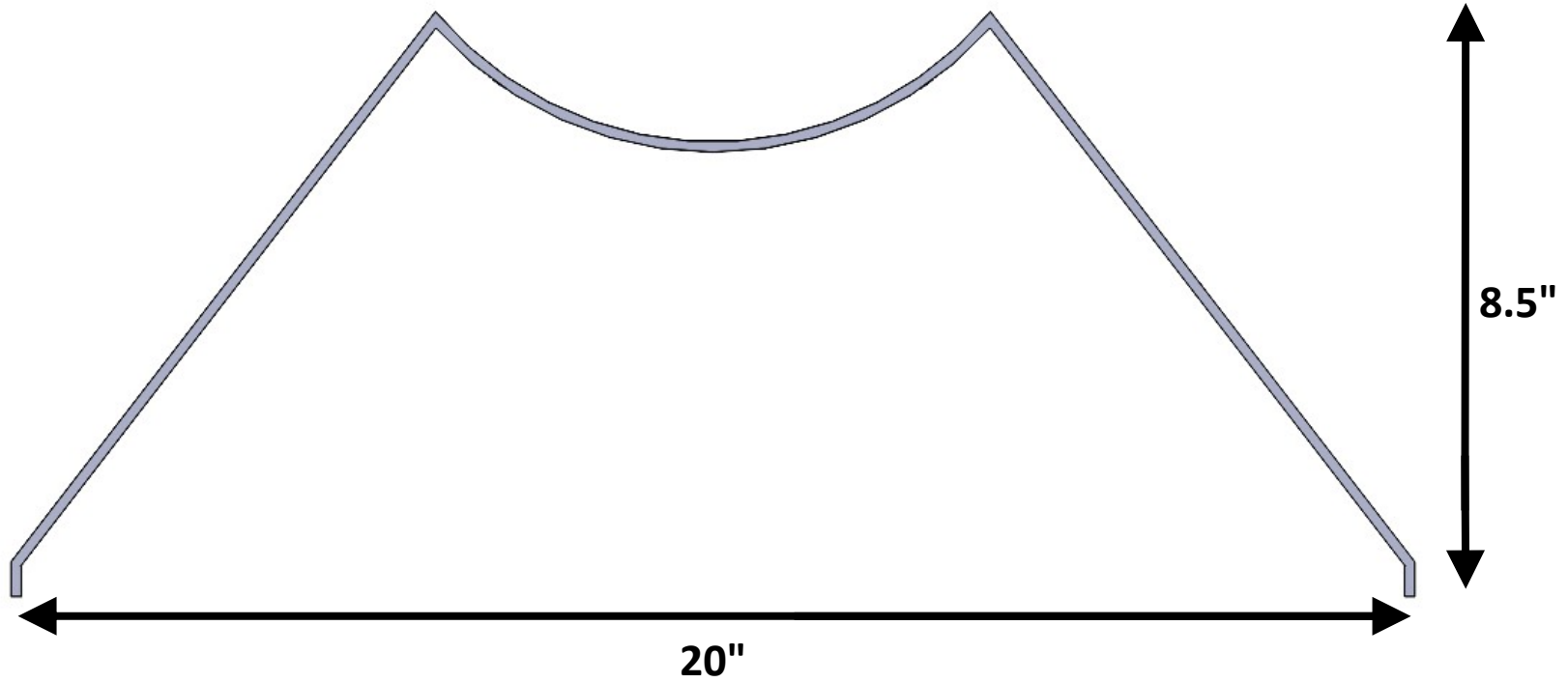
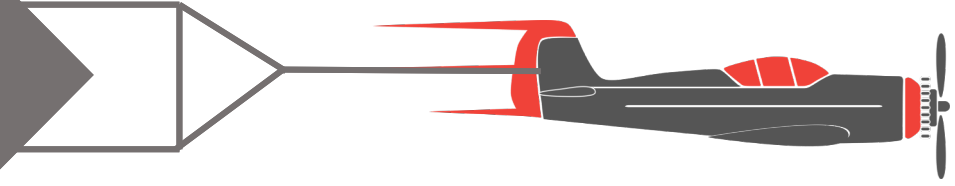

Joseph Figari

Landing Gear

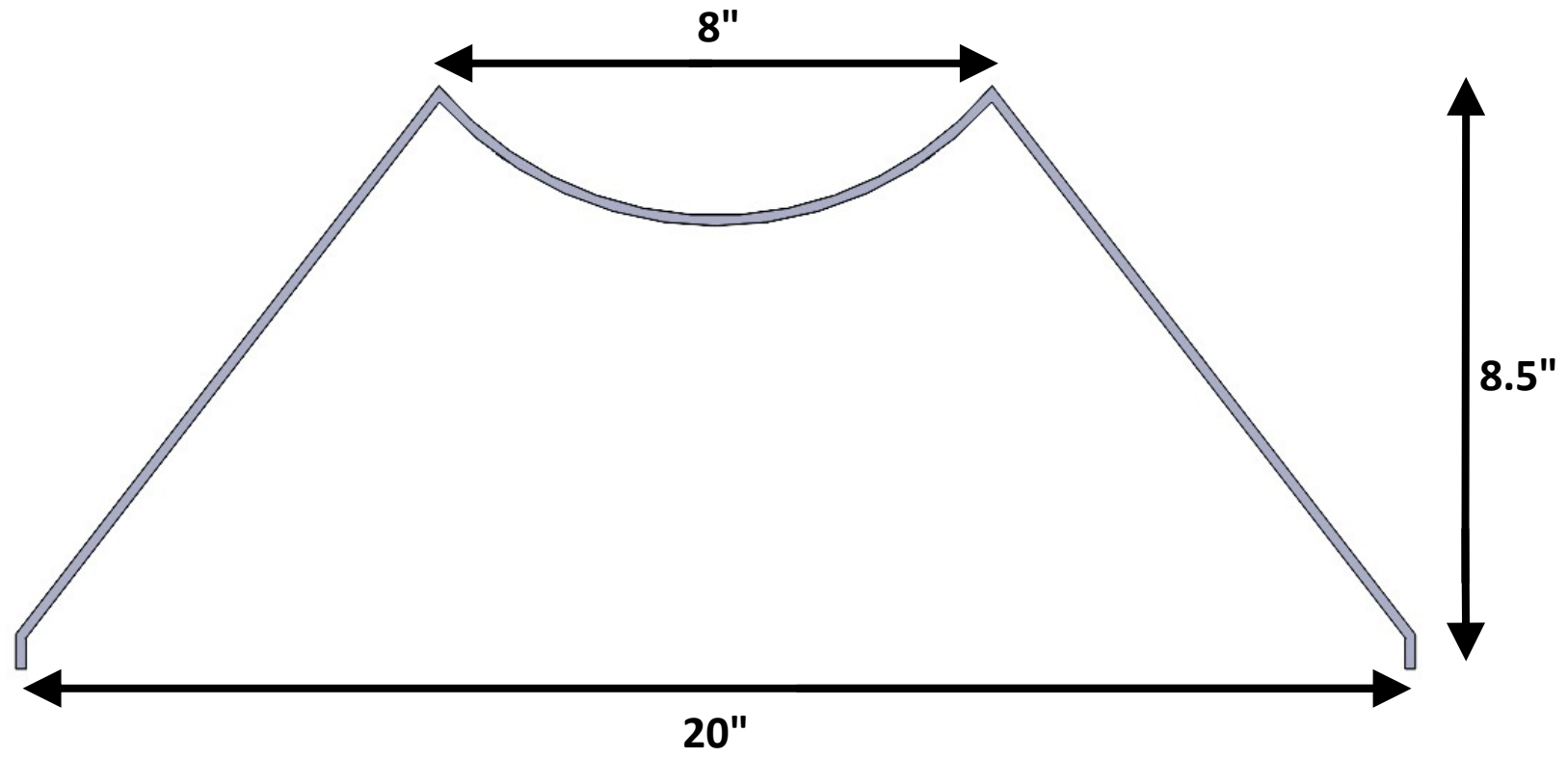
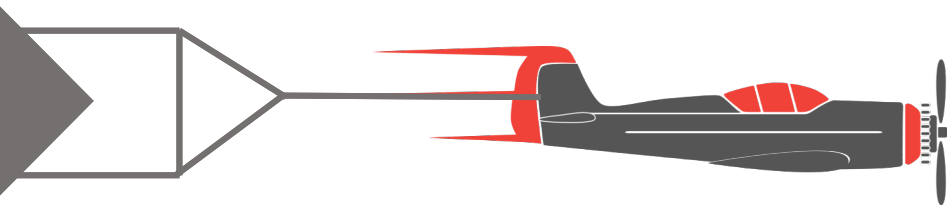

Joseph Figari

Landing Gear

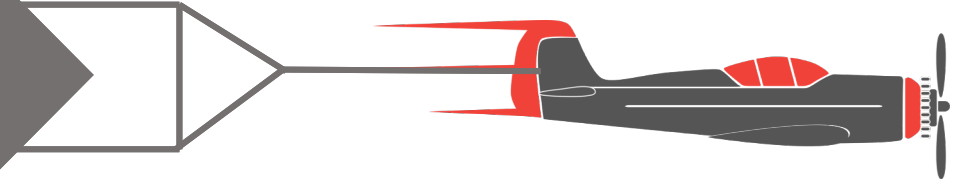

Jacob Pifer

Landing Gear

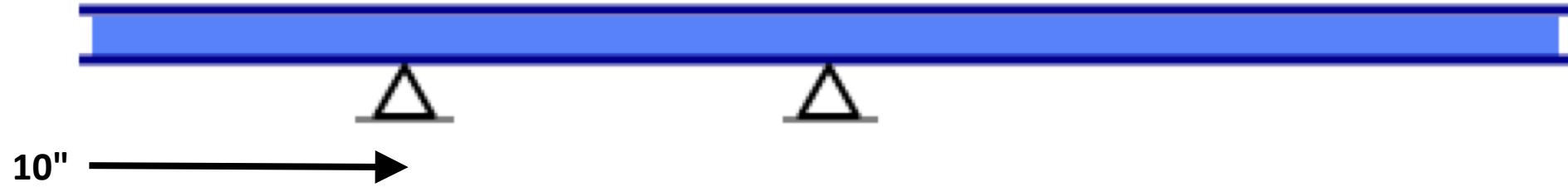
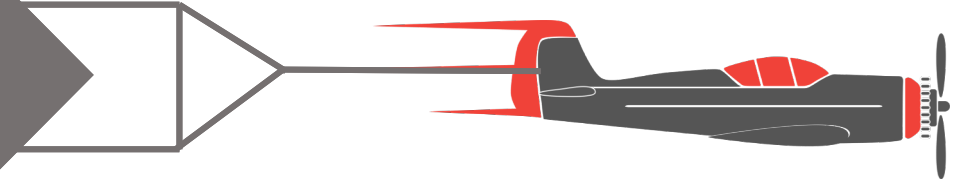

Jacob Pifer

Landing Gear

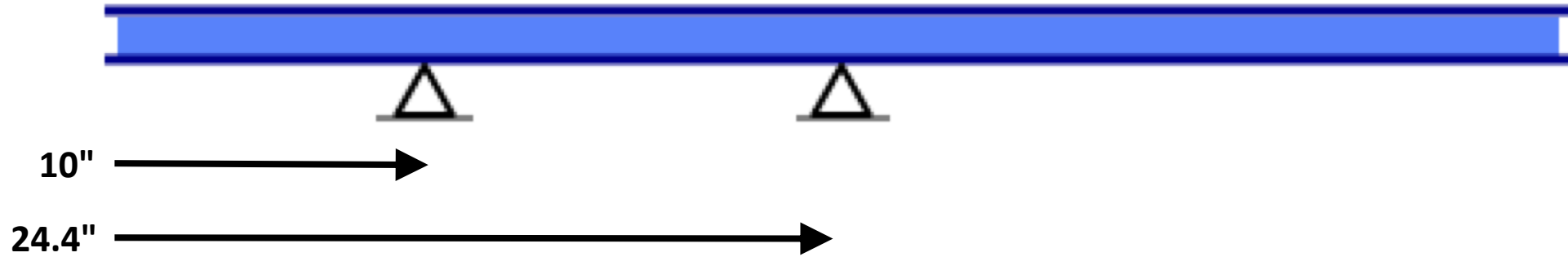
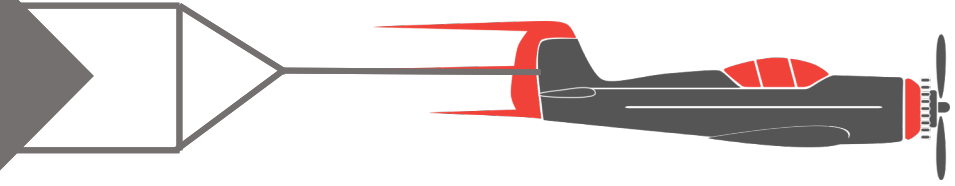

Jacob Pifer

Landing Gear

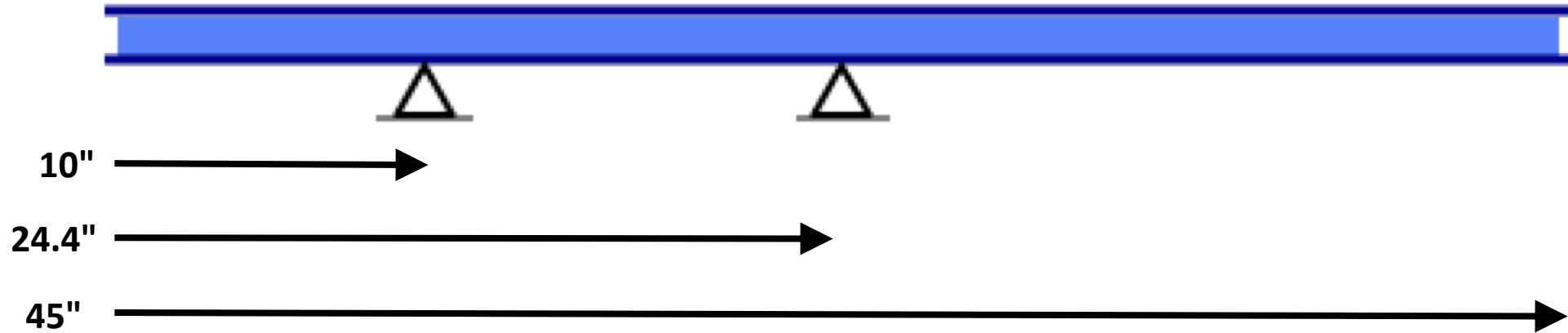
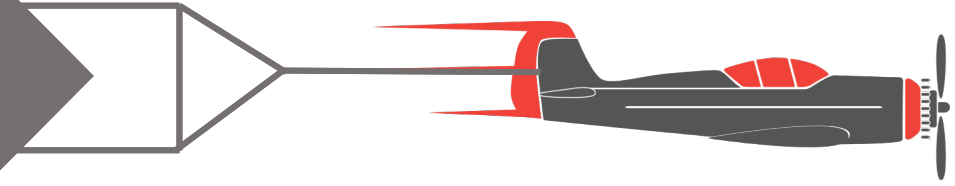

Jacob Pifer

Landing Gear

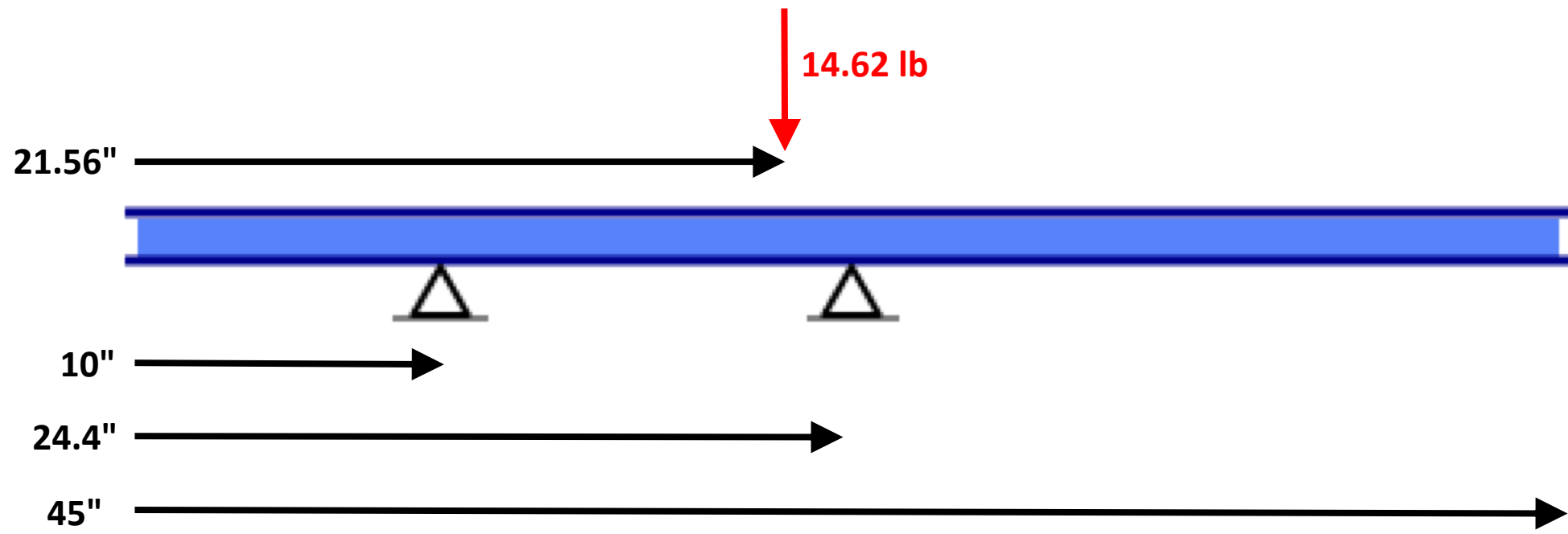
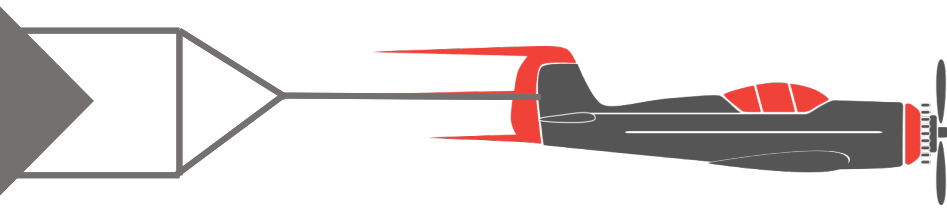

Jacob Pifer

Landing Gear

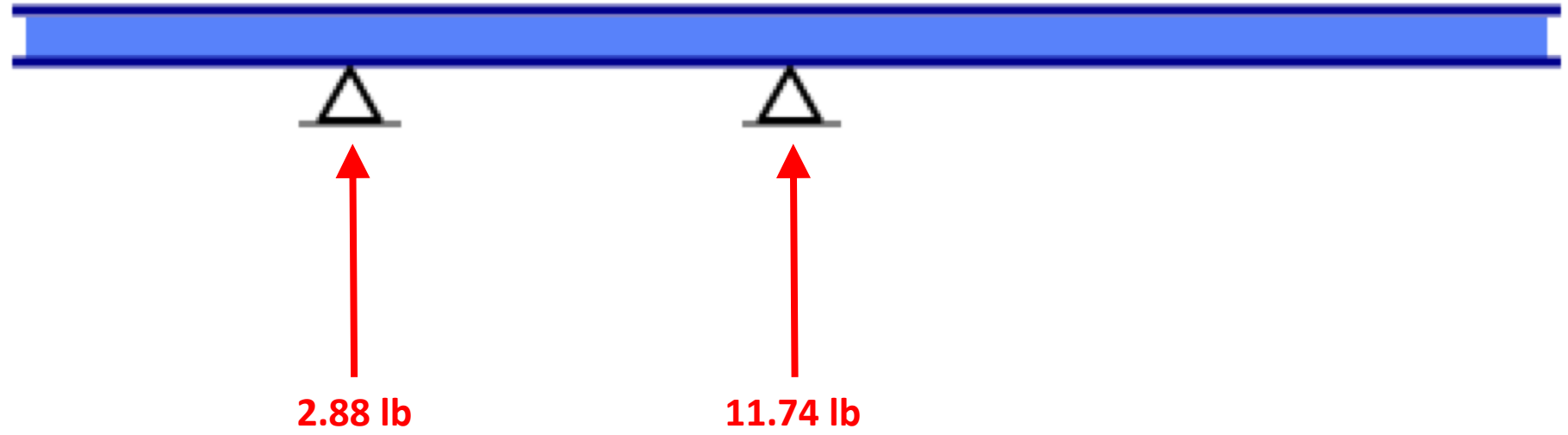
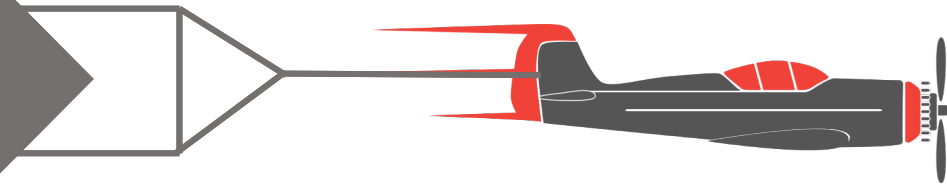

Jacob Pifer

Project Brief Summary

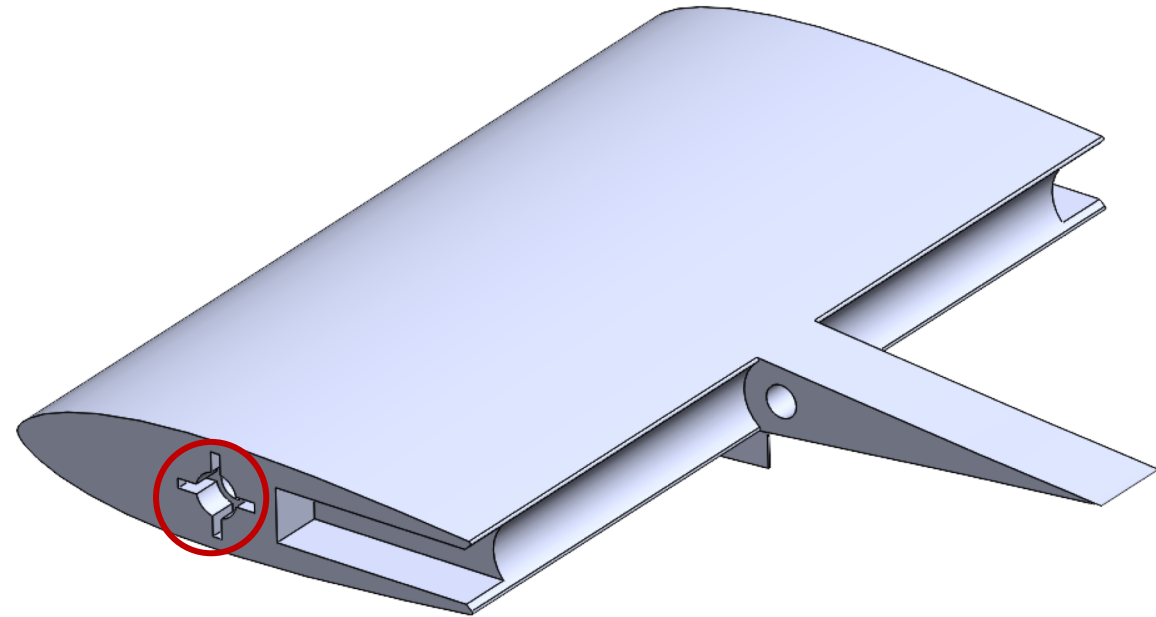
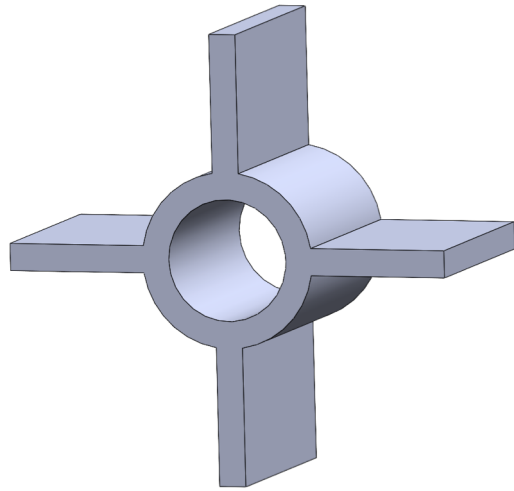
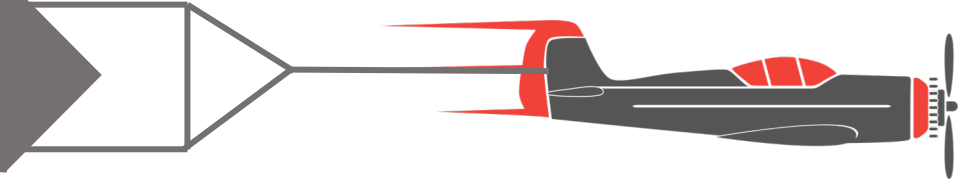

Lauren Chin

Project Brief Summary

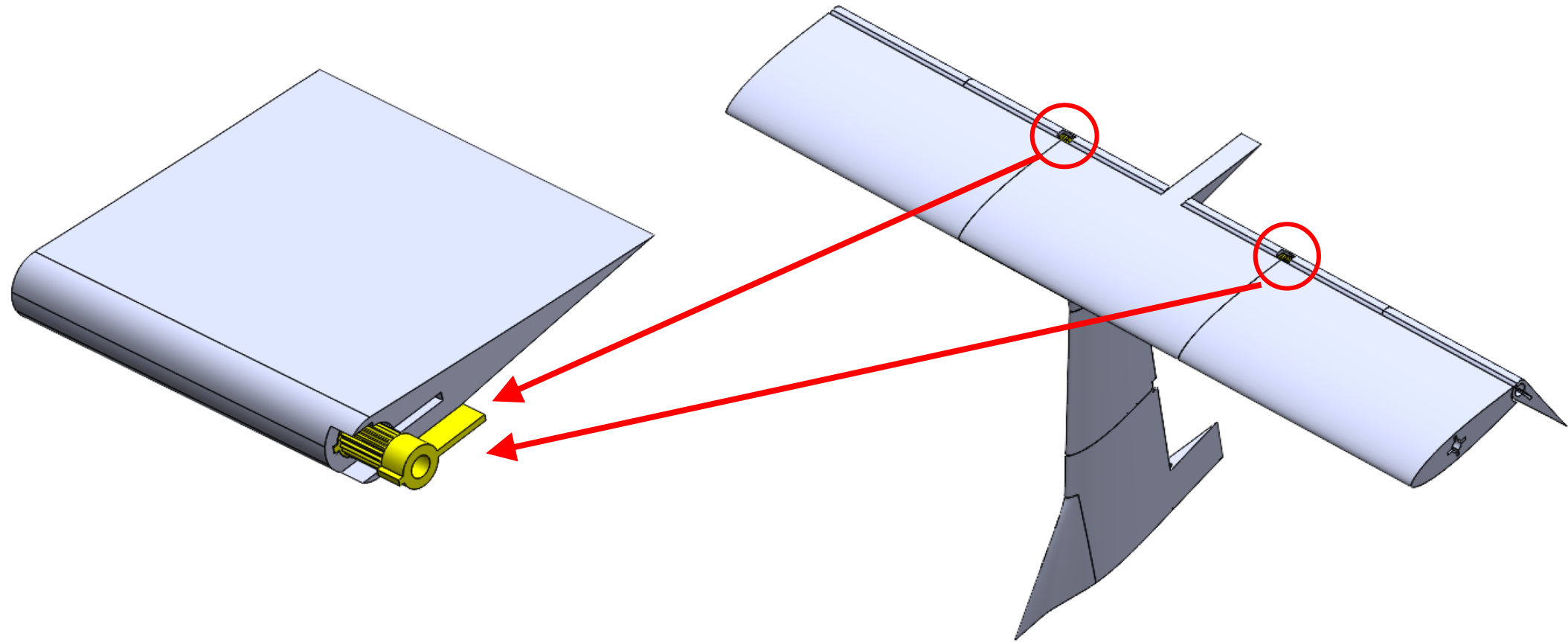
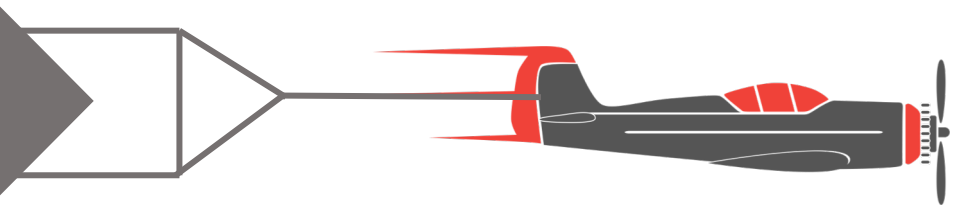

Lauren Chin

Project Brief Summary

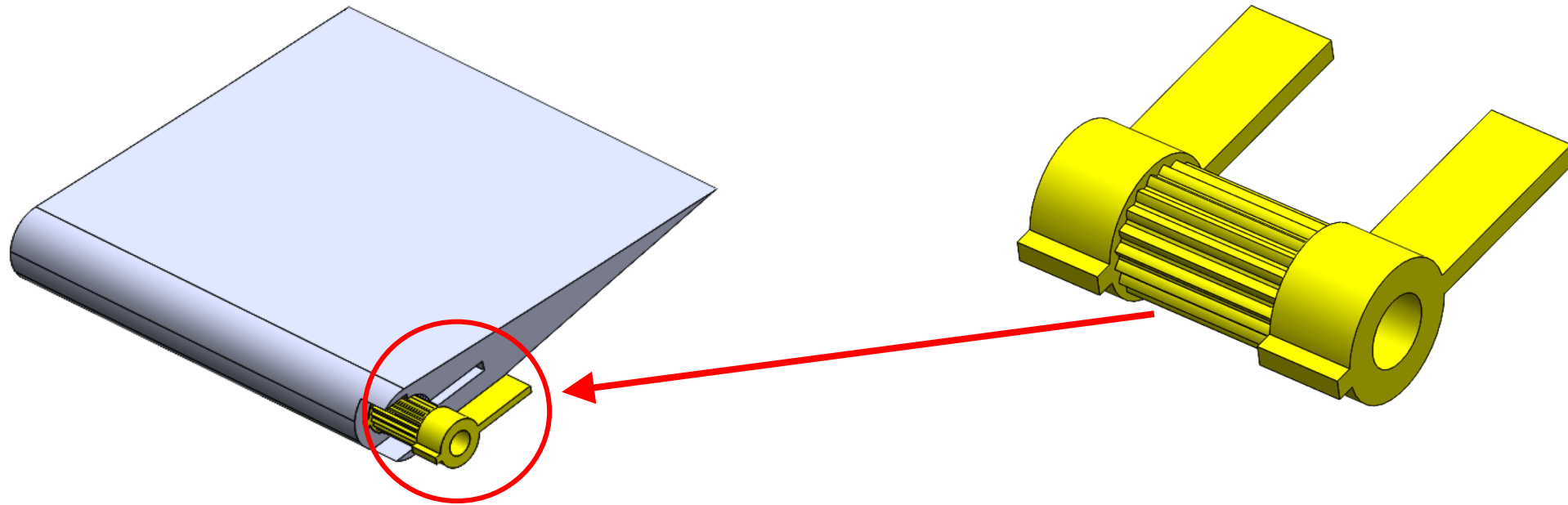
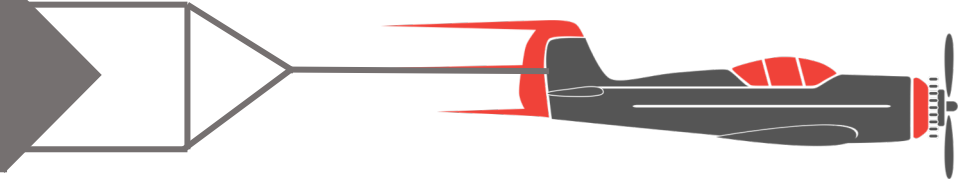

Lauren Chin

Project Brief Summary

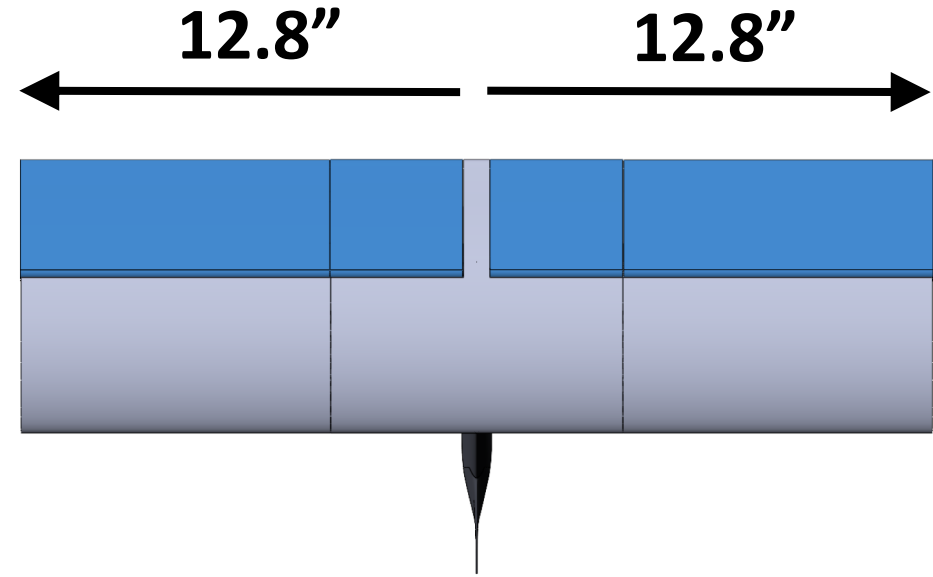
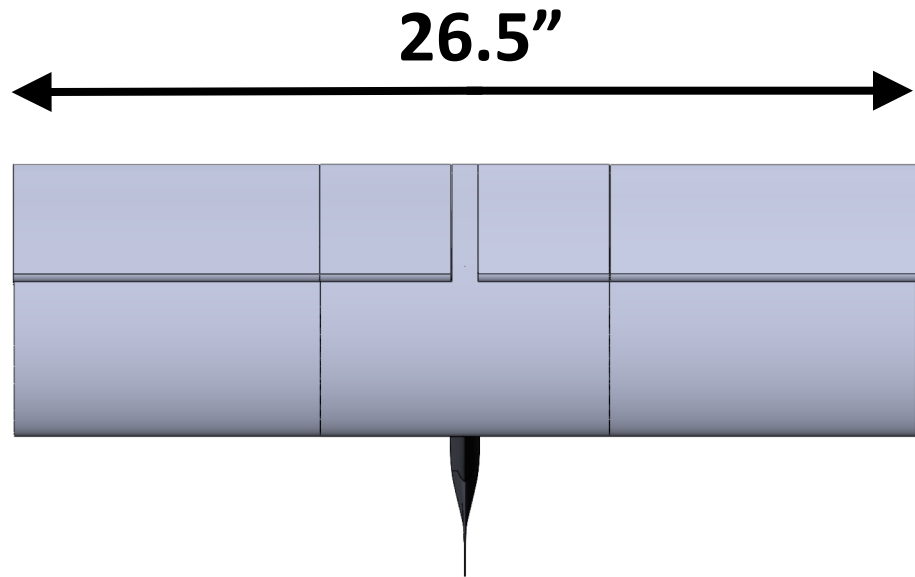
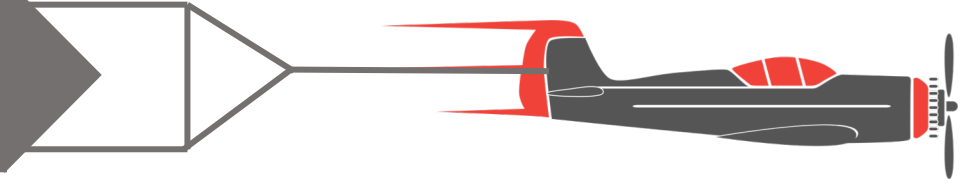

Lauren Chin

Project Brief Summary

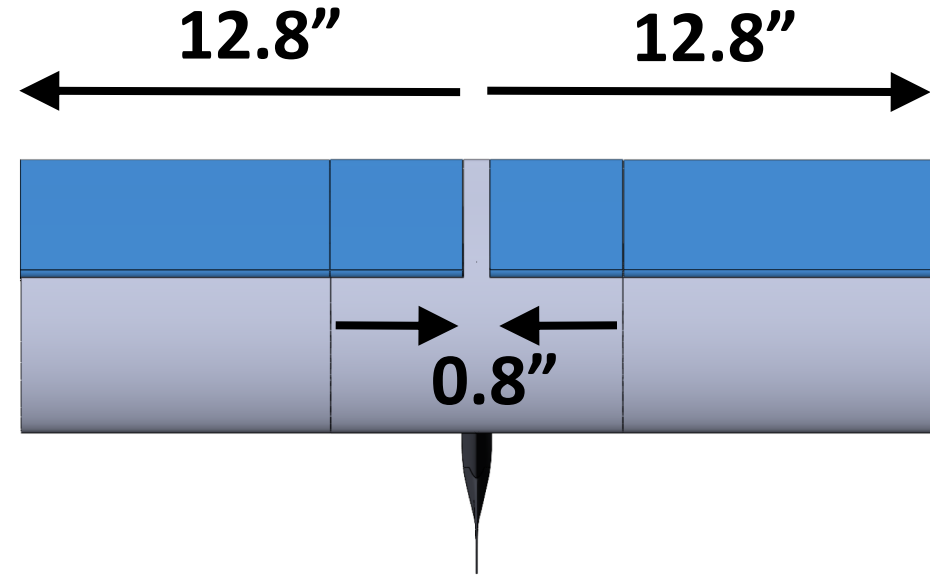
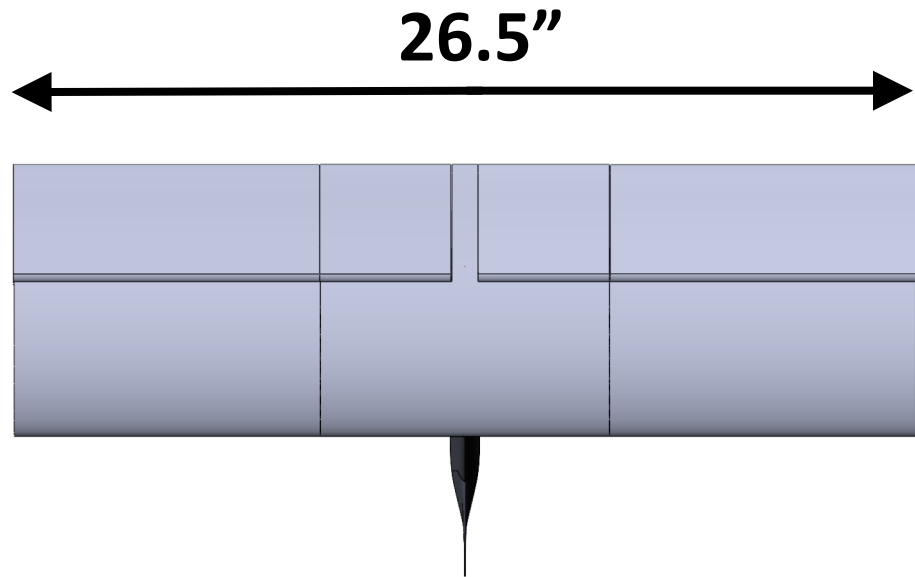
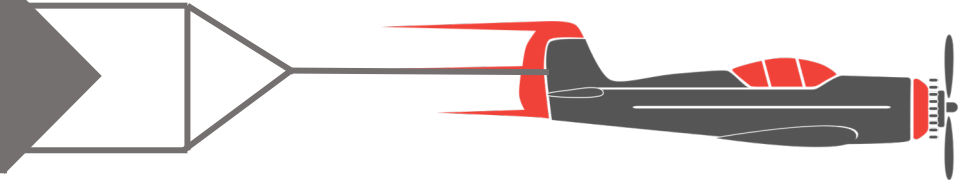

Lauren Chin

Project Brief Summary

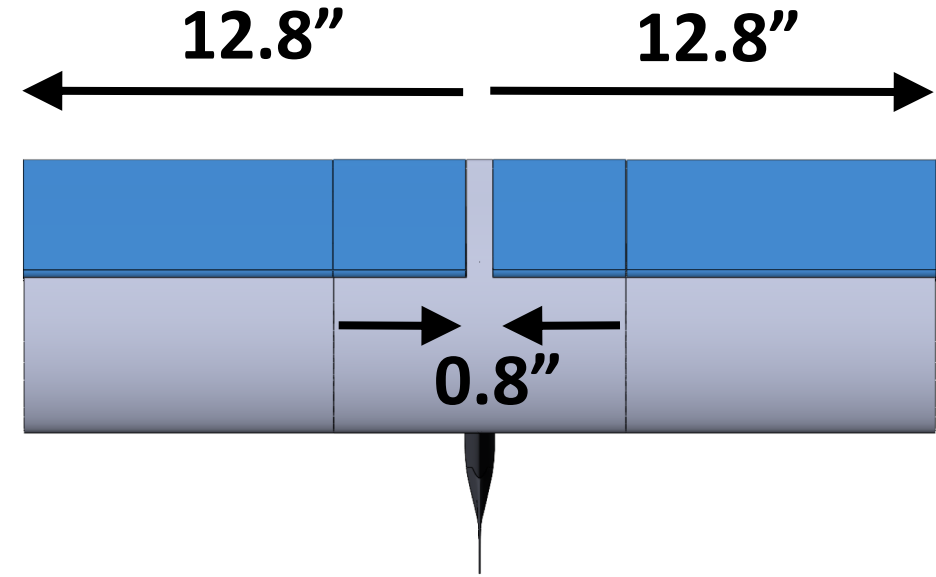
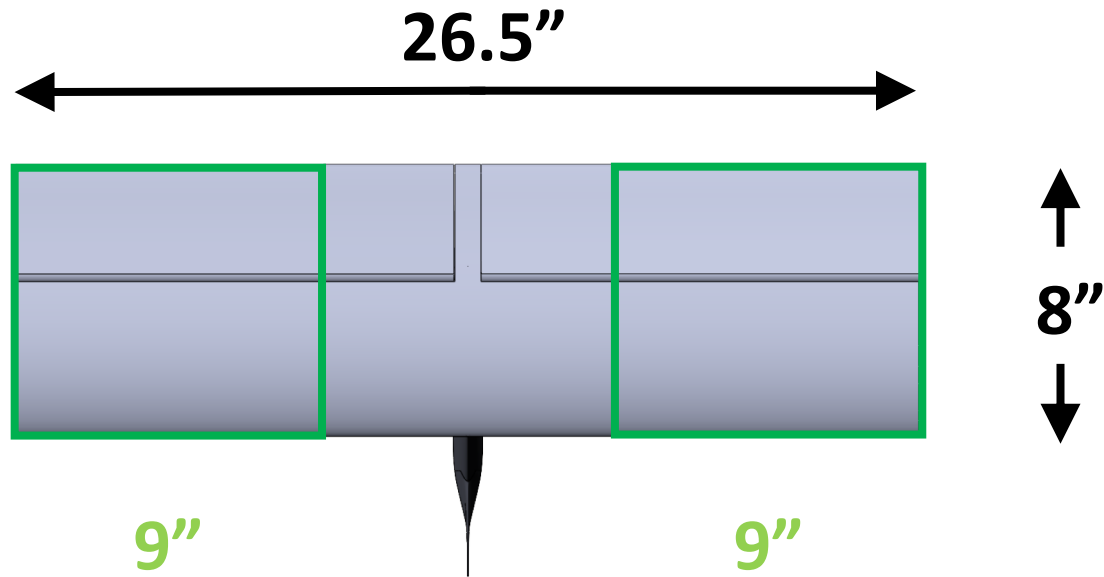
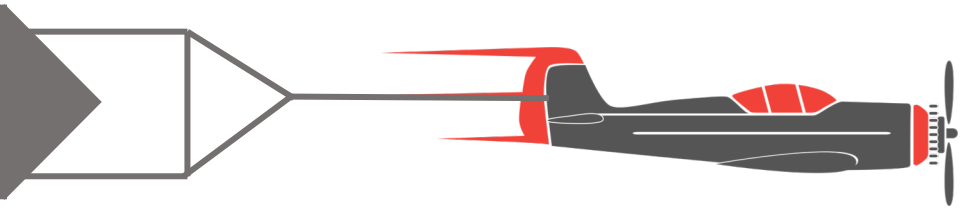

Lauren Chin

Project Brief Summary

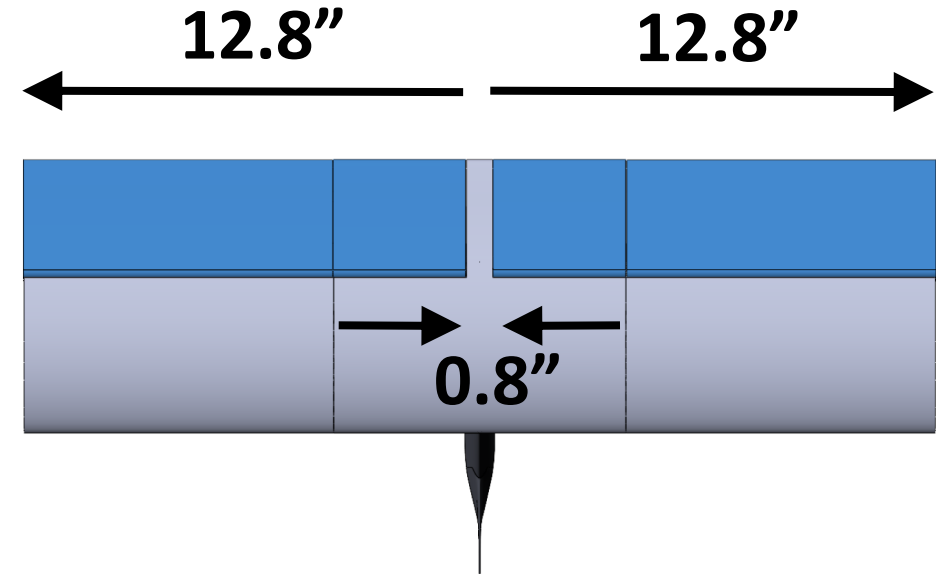
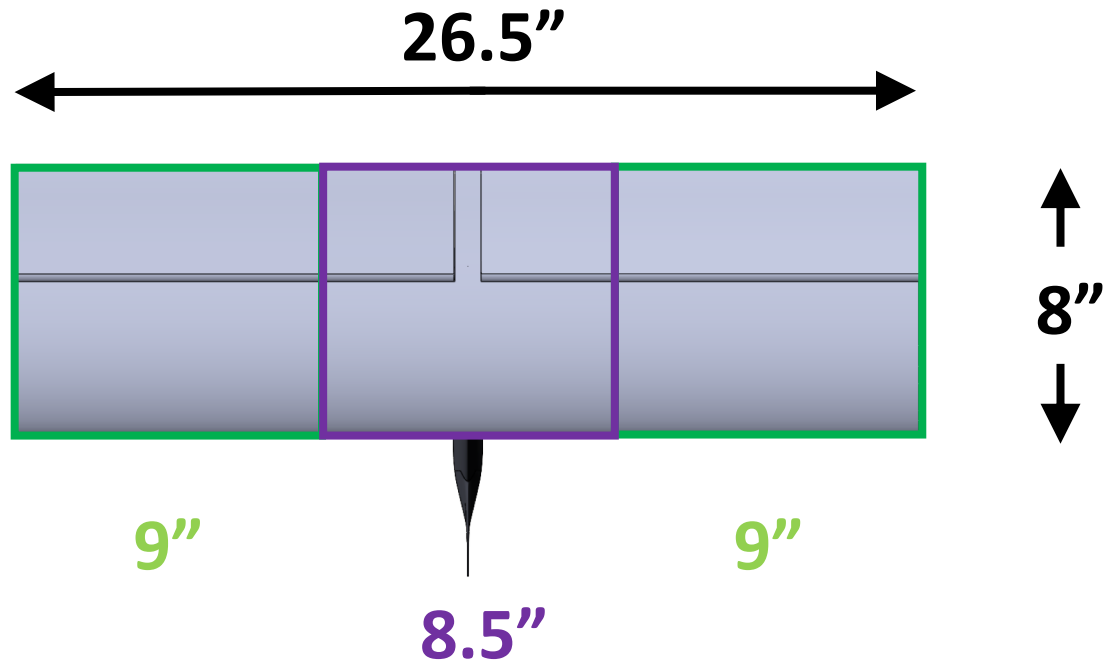
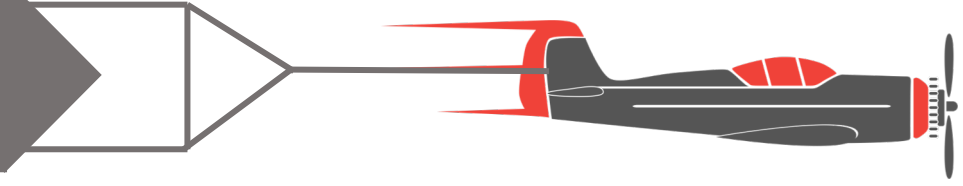

Lauren Chin

Project Brief Summary

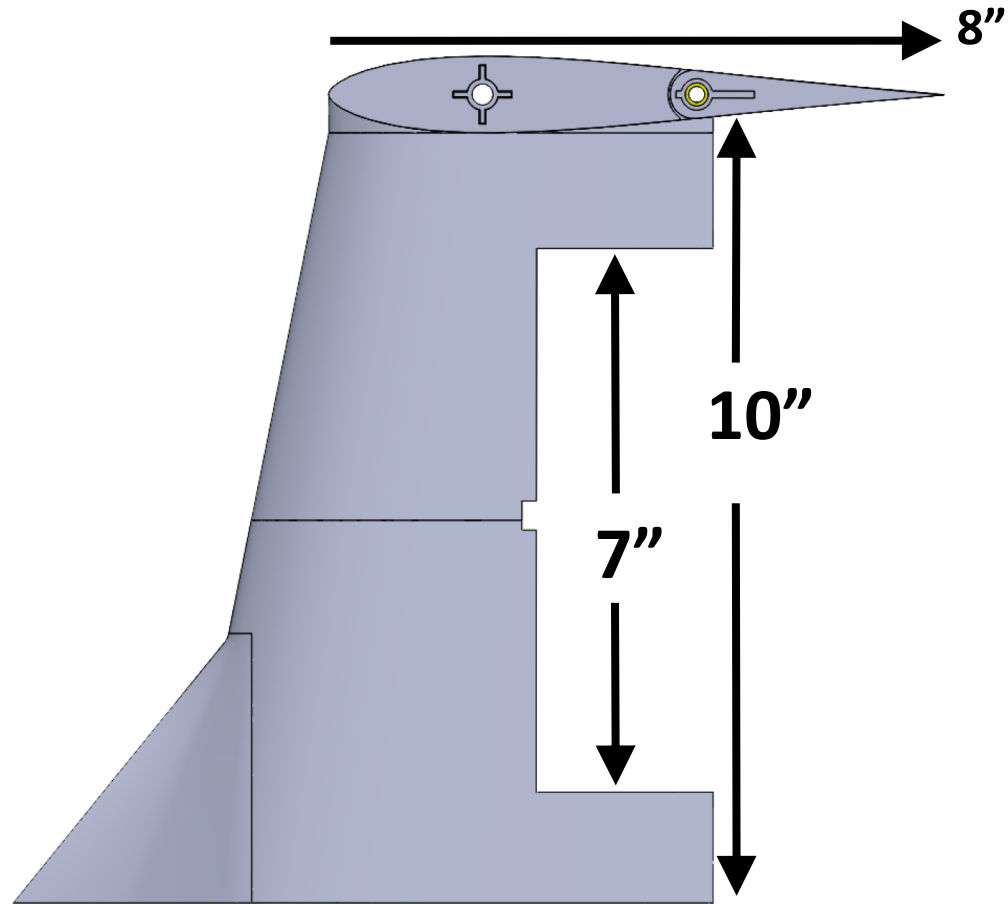
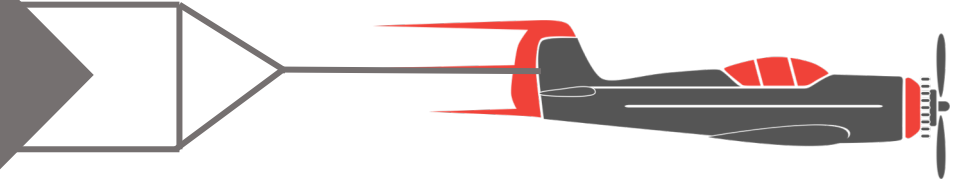

Lauren Chin

Project Brief Summary

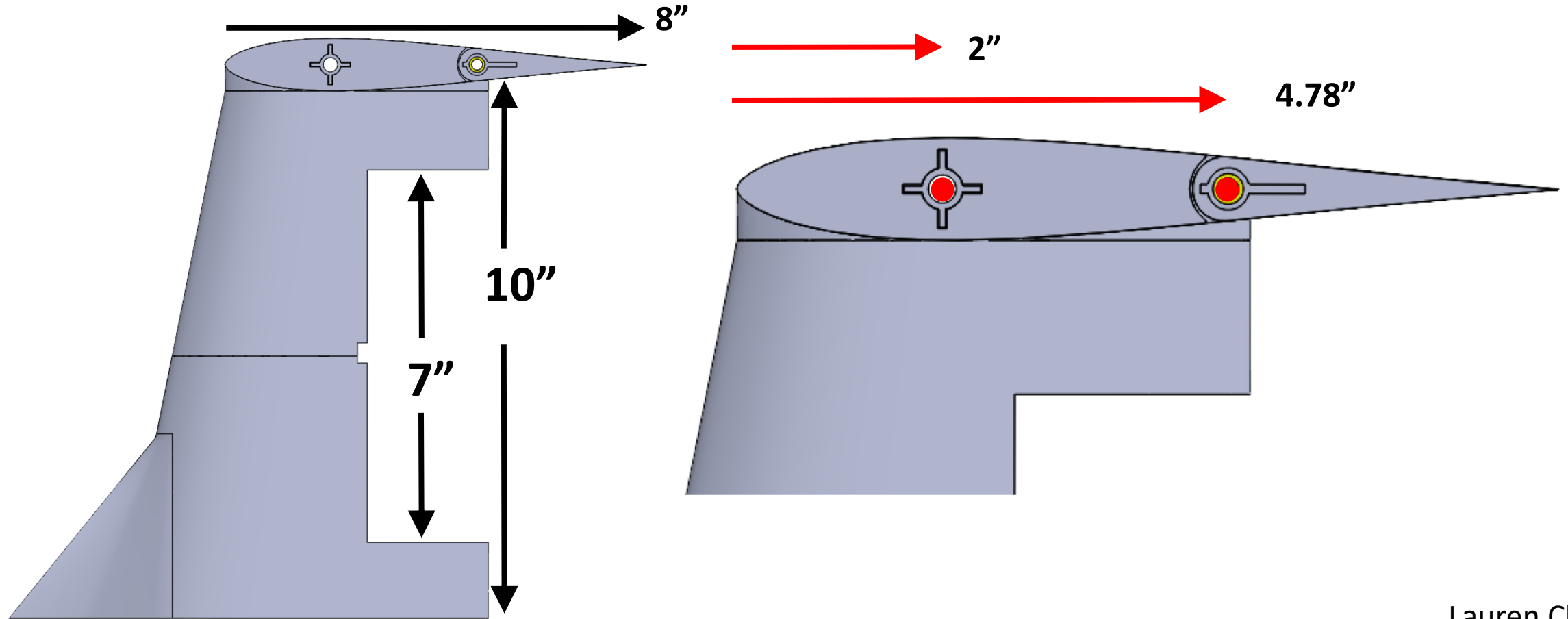
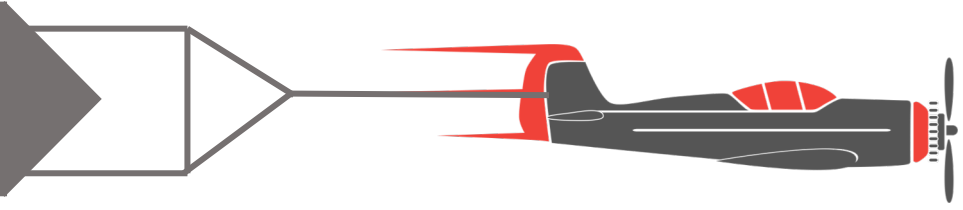

Lauren Chin

Project Brief Summary

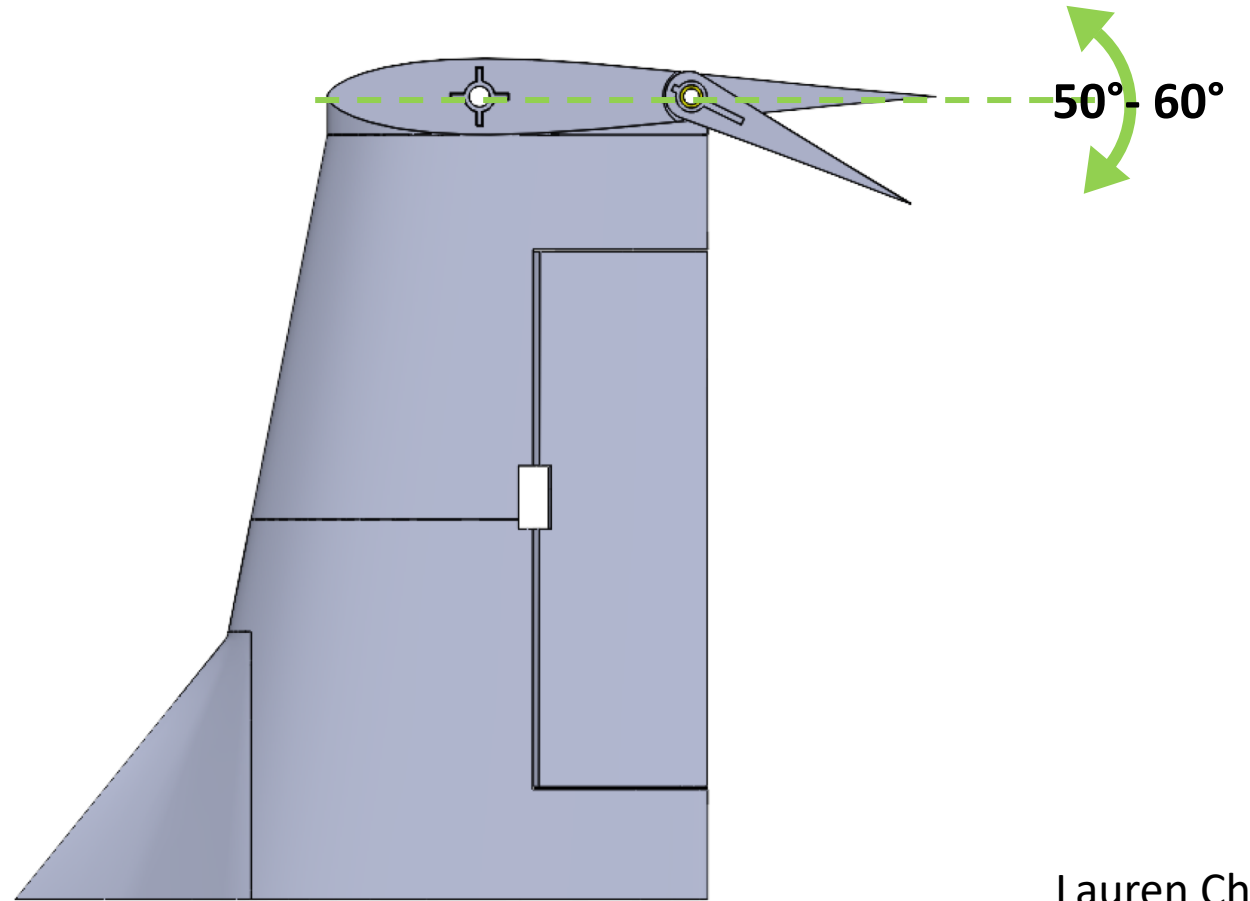
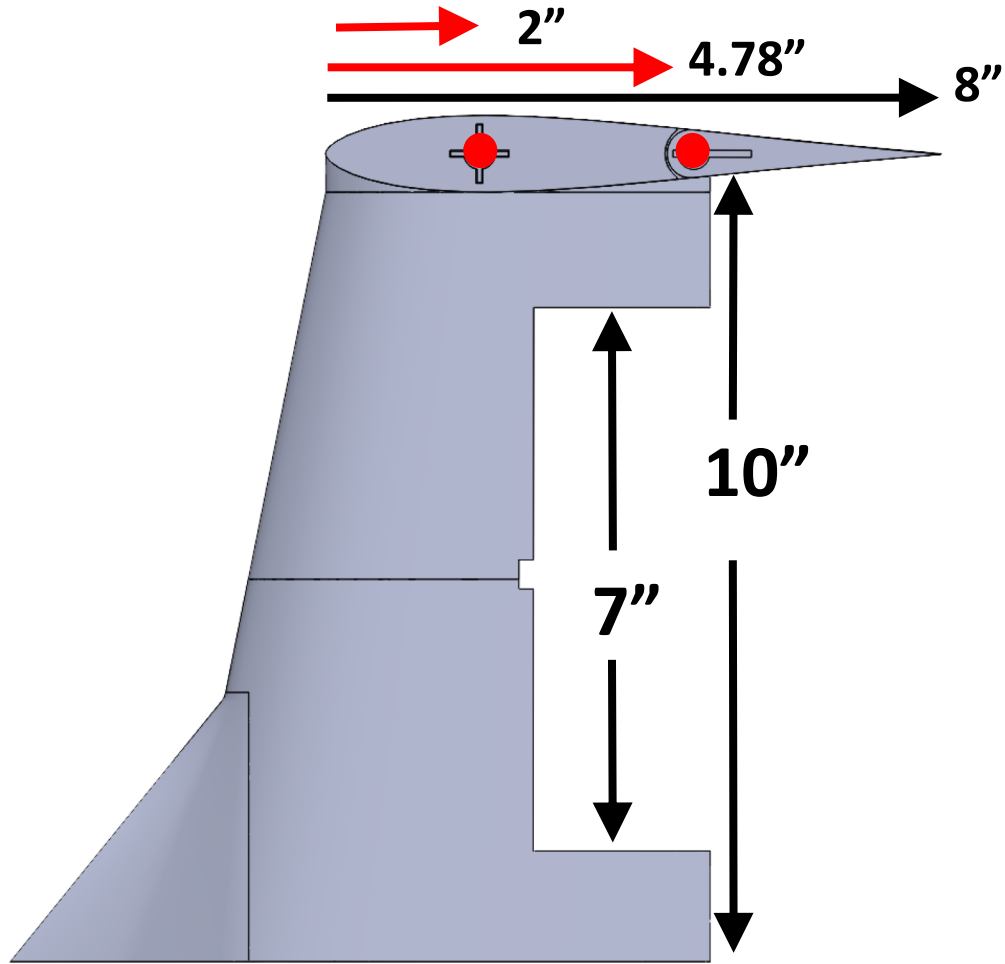
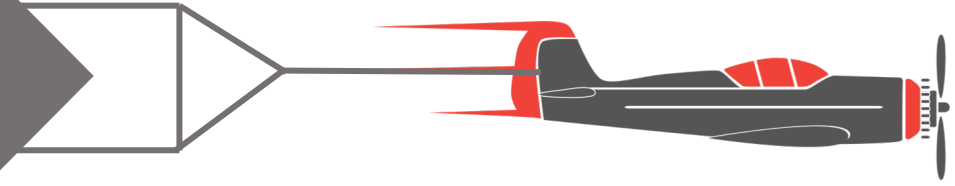

Lauren Chin

Project Brief Summary

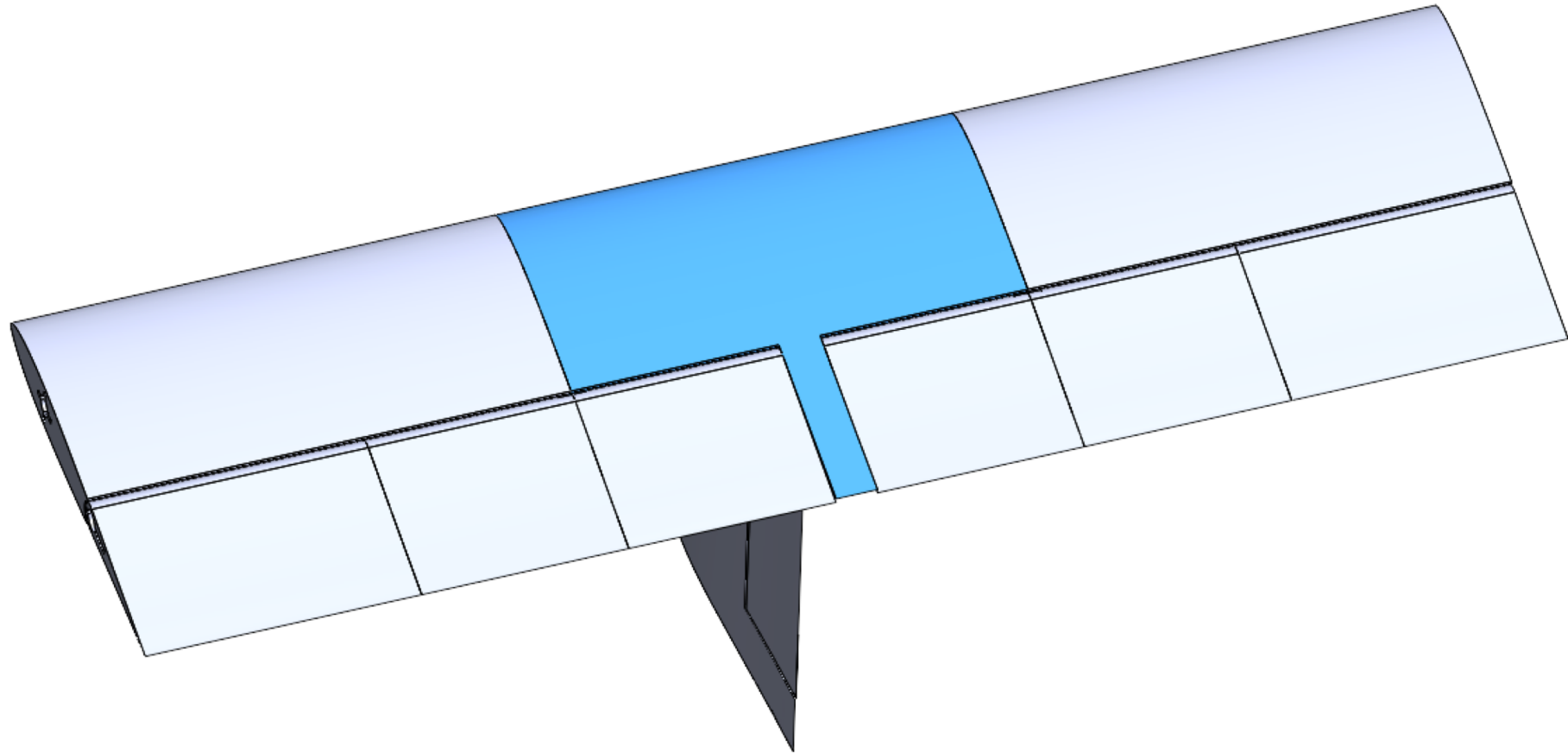
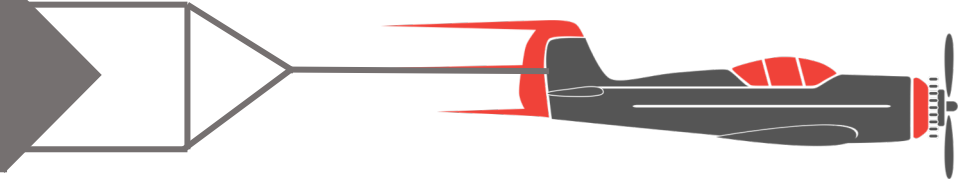

Lauren Chin

Project Brief Summary

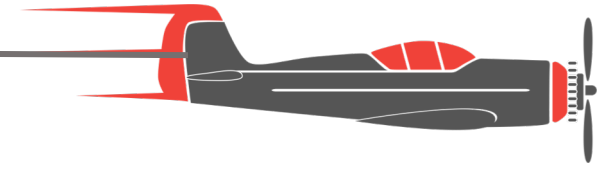

15° Right →

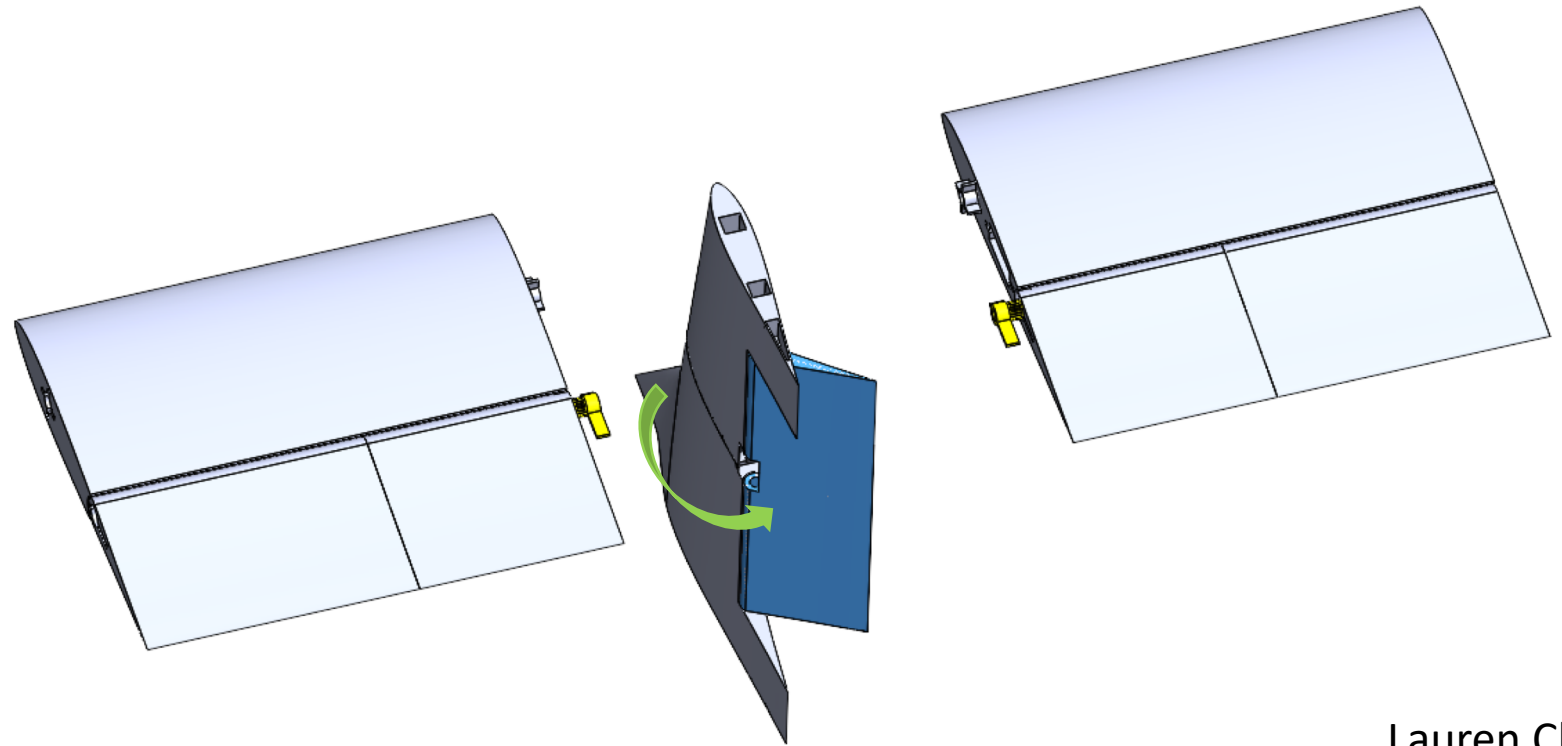

Lauren Chin

Project Brief Summary

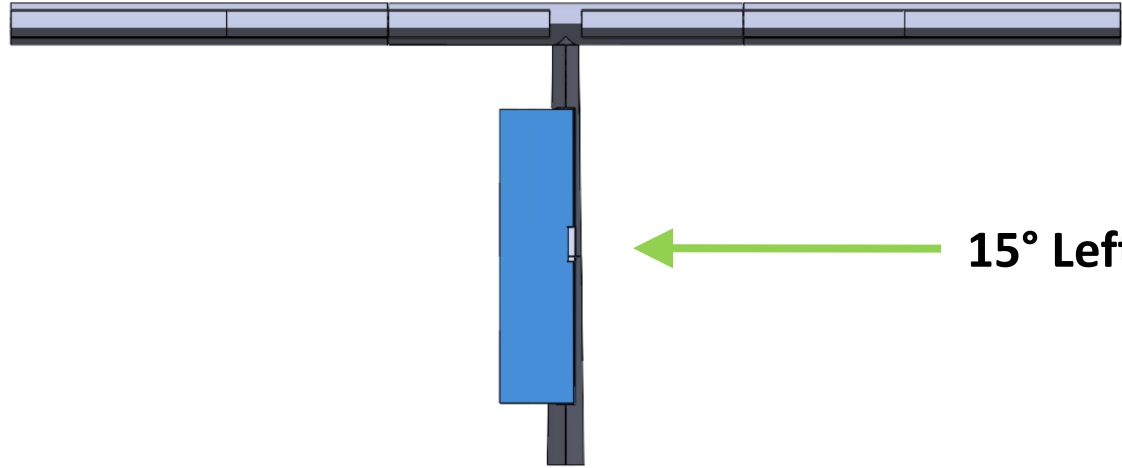
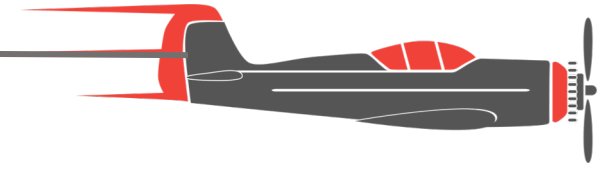

15° Left

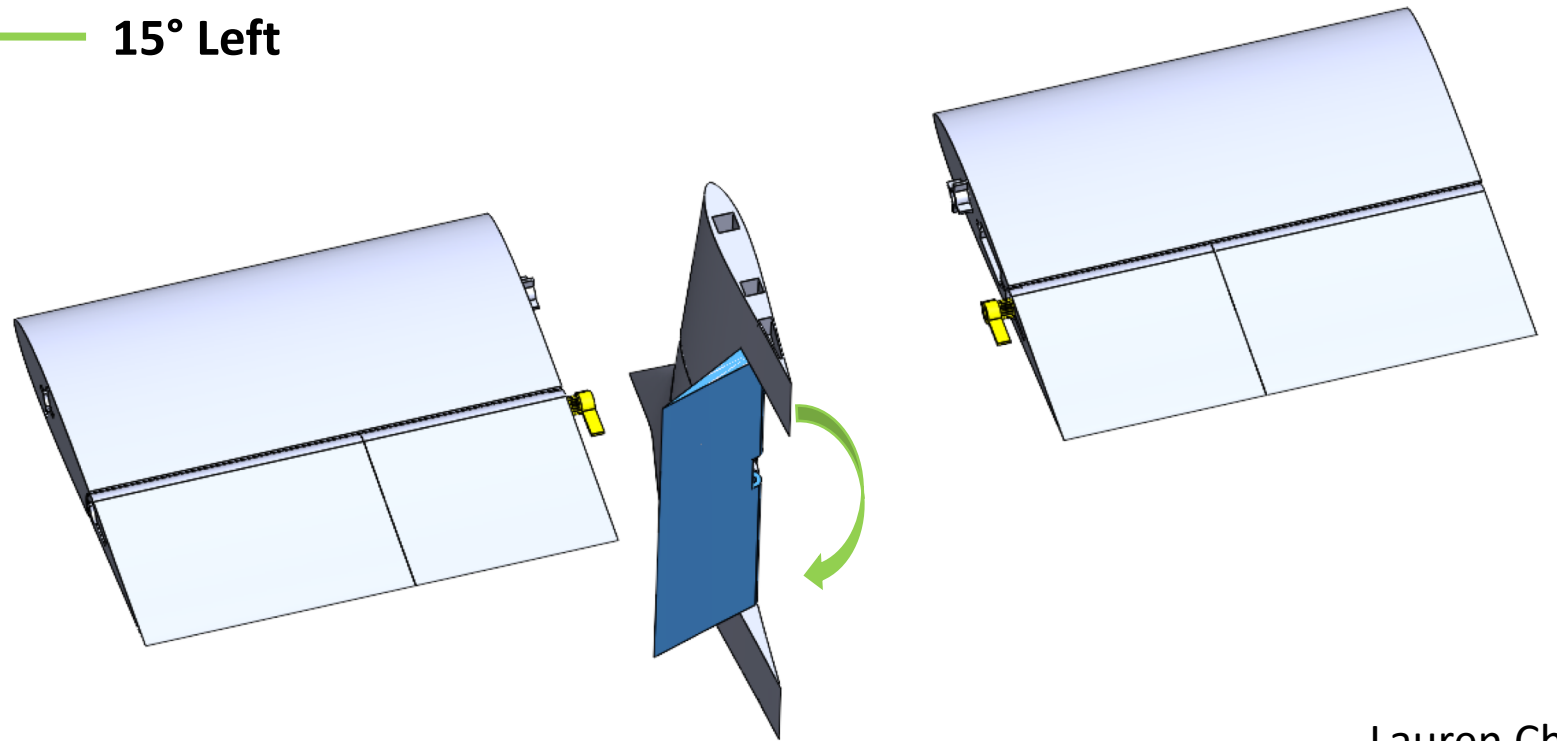

Lauren Chin

Project Brief Summary

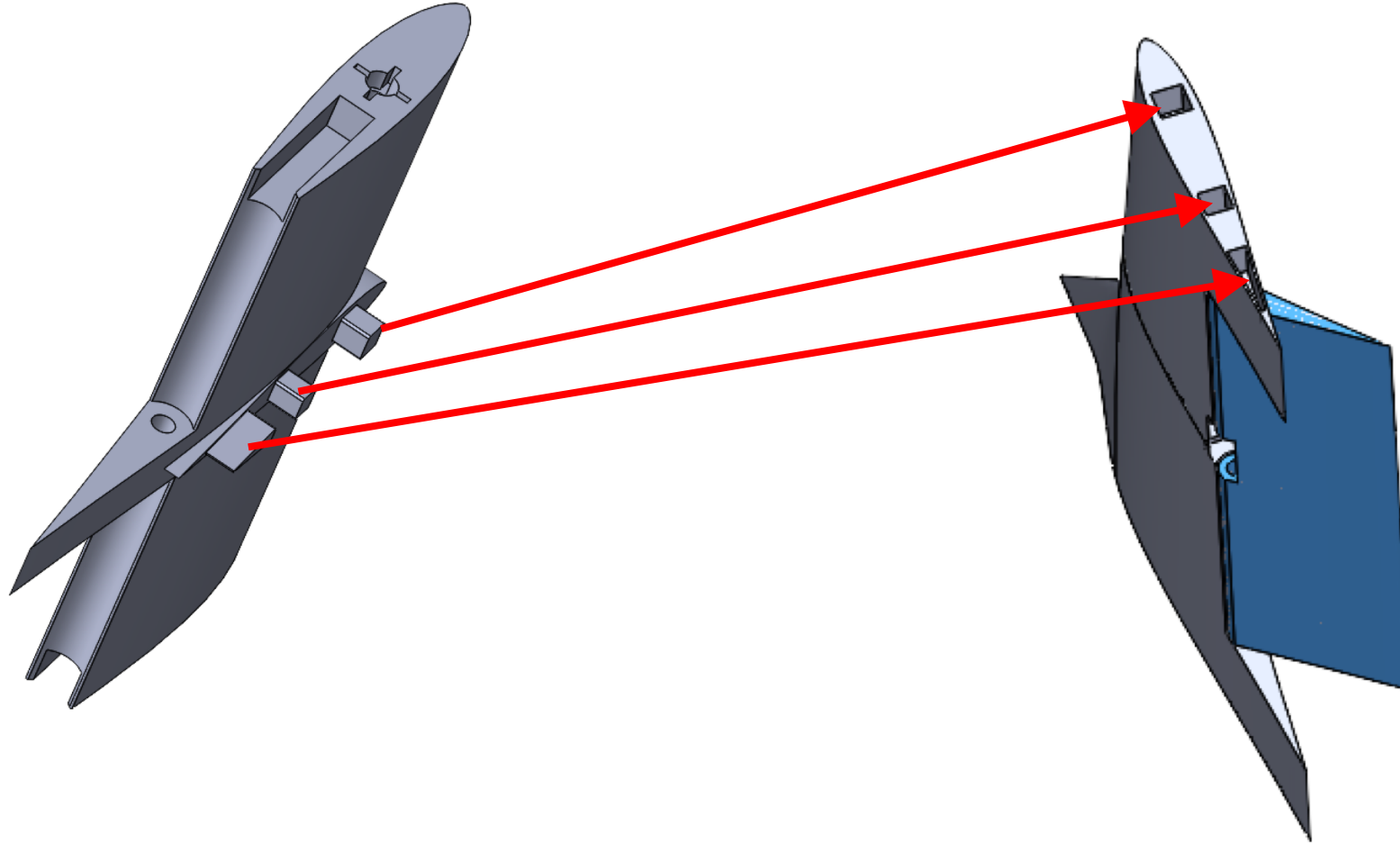
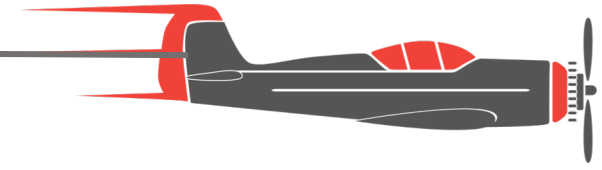

Lauren Chin

In the Works

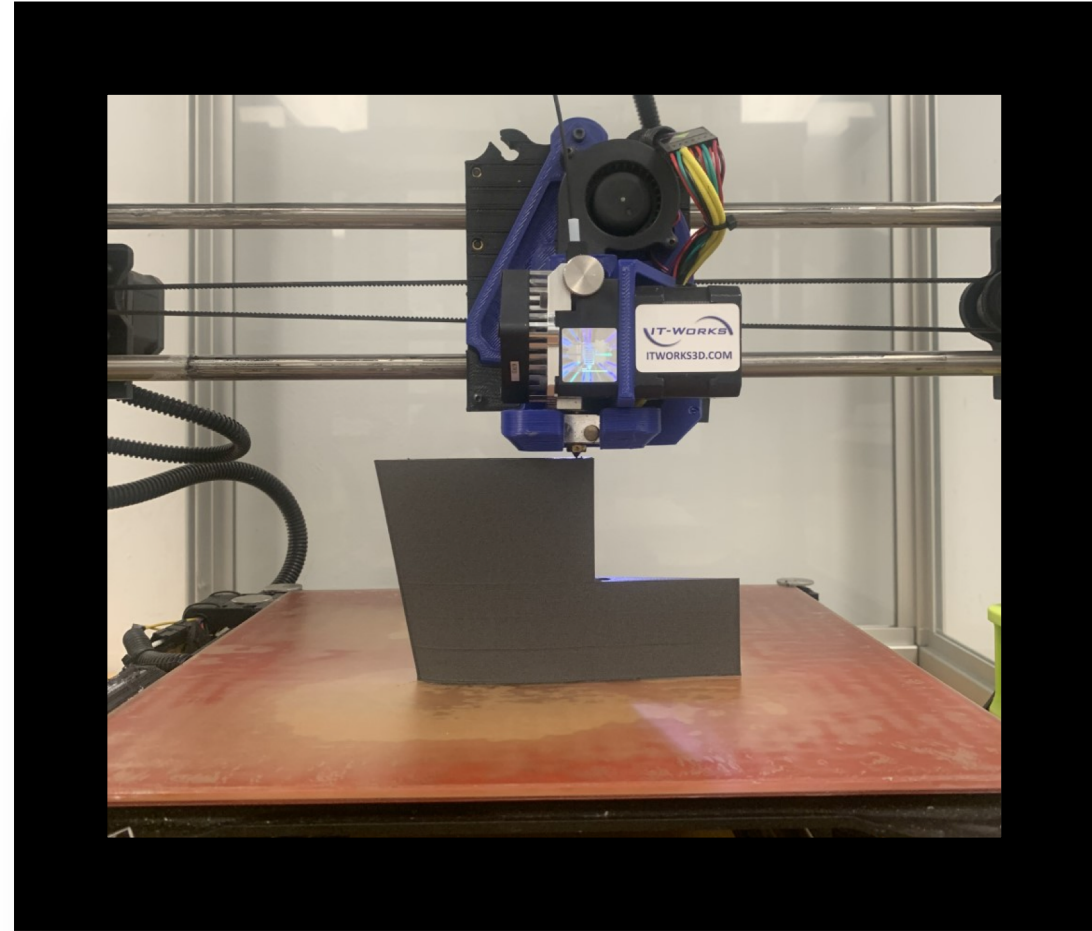
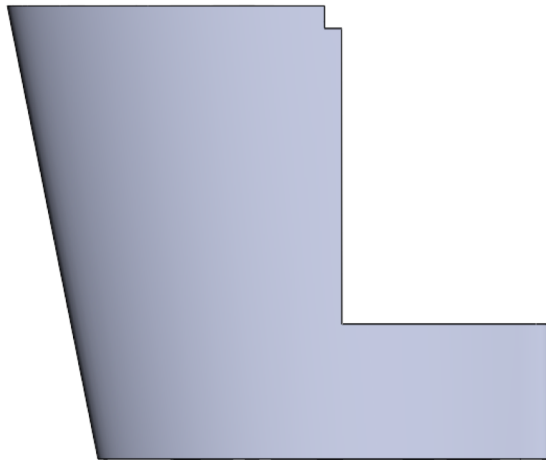
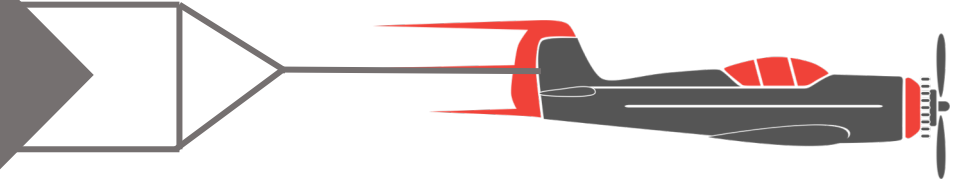

Joseph Figari

In the Works

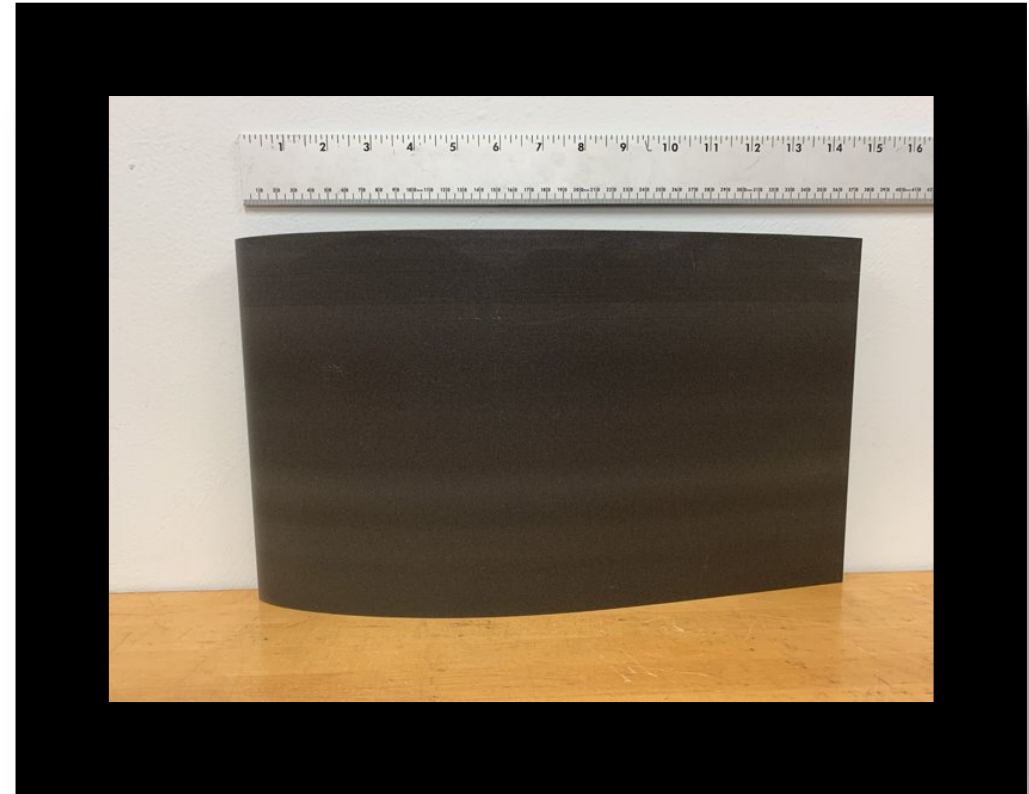
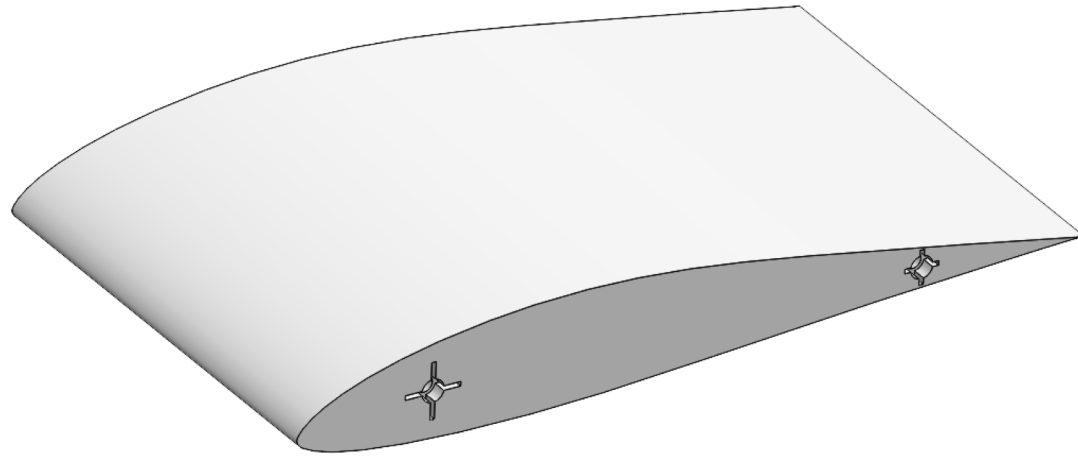
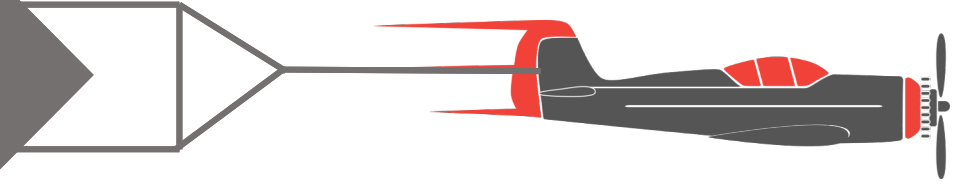

Joseph Figari

In the Works

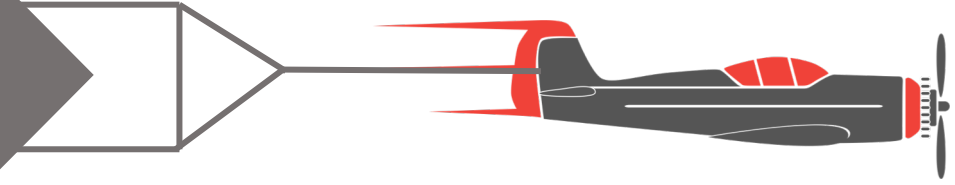

- Servos have been ordered
 - Spars have been ordered
 - Bow ties have been printed
- CHANGE TO POINTY BULLETS

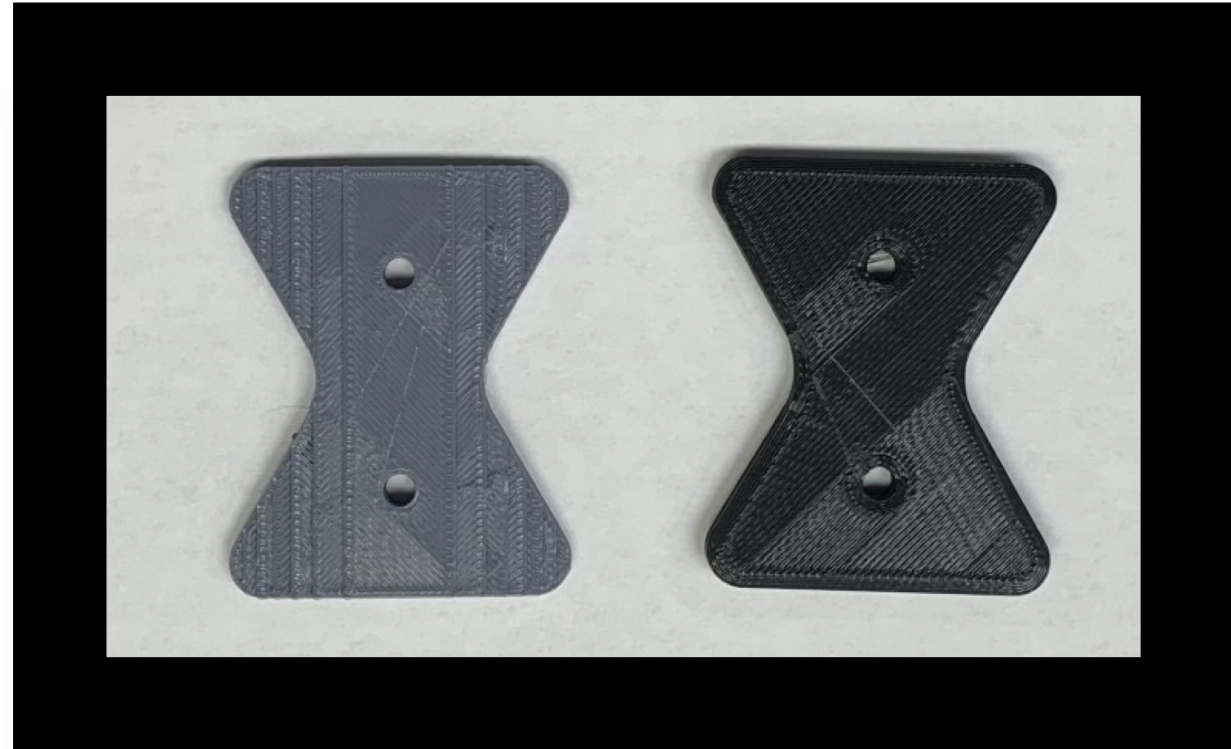

Joseph Figari

Future Work

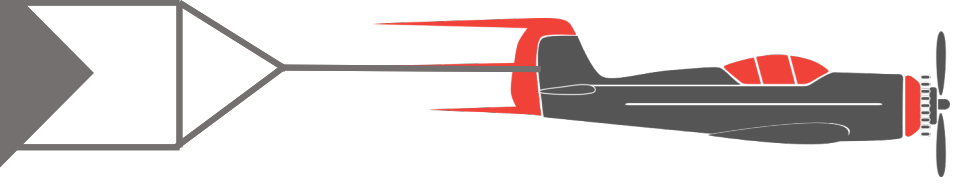

- Design ways to secure the electronics inside the fuselage
- Build the landing gear
- Continue 3D printing the parts
- Set a date and fill out needed paperwork for the test flight with
Seminole RC

Jacob Pifer

Key Takeaways

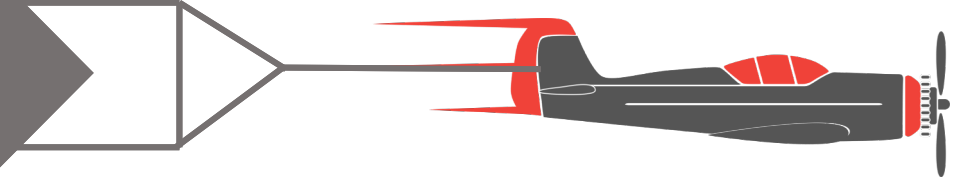

- Seminole RC Club will be helping with a test flight
- The plane is still being built within competition rules
- Printing has started and will continue
- All parts must be made with printing in mind

Jacob Pifer

References

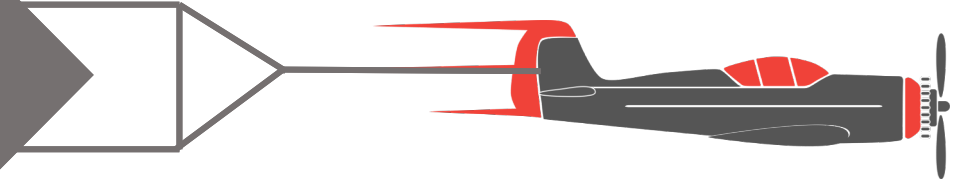

- 2021 Collegiate Series SAE Design Rulebook (2021). *SAE Aero Design*.
<https://www.saeaerodesign.com/cdsweb/gen/DocumentResources.aspx>
- Aguirre, N., Evans, L.,... Silver, Z. (2020). T513: SAE Aero Design Operations Manual. *Team 513: SAE Aero Design East Competition*, 47-56.
- ADD MANUAL

Jacob Pifer

Back-Up Slides

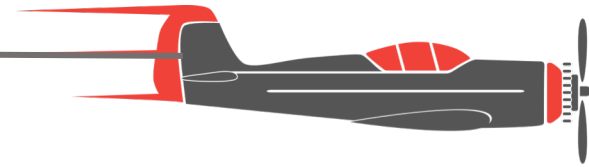

Assembling Methods: Spars

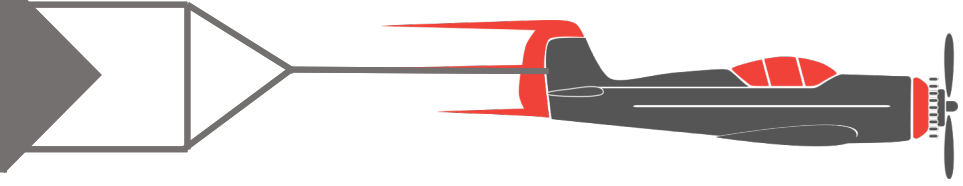

- Plane uses spars to assemble the wings
- Each wing set has two spars
- Small crosses are also used to help lock the wings together
- Ends of the spars are threaded so screws can be used to secure the parts

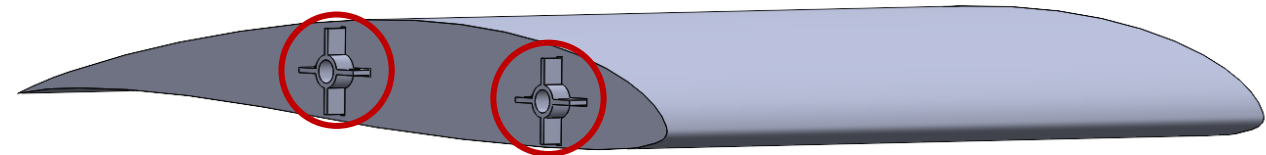
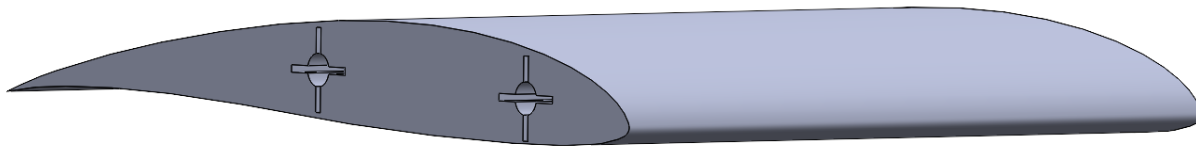
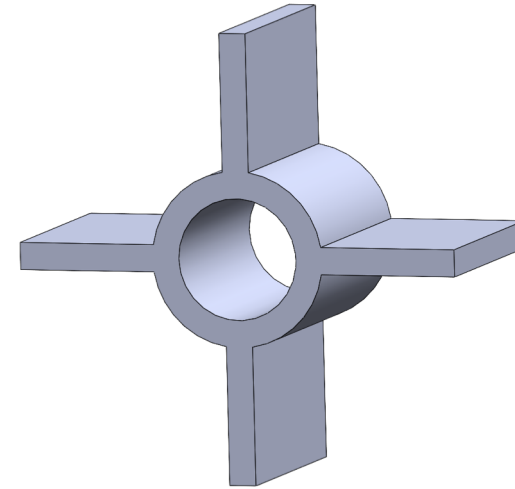

Lauren Chin

Infill/ Printing Methods

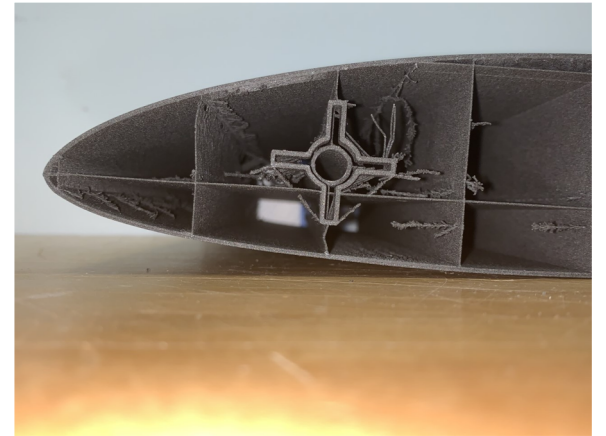
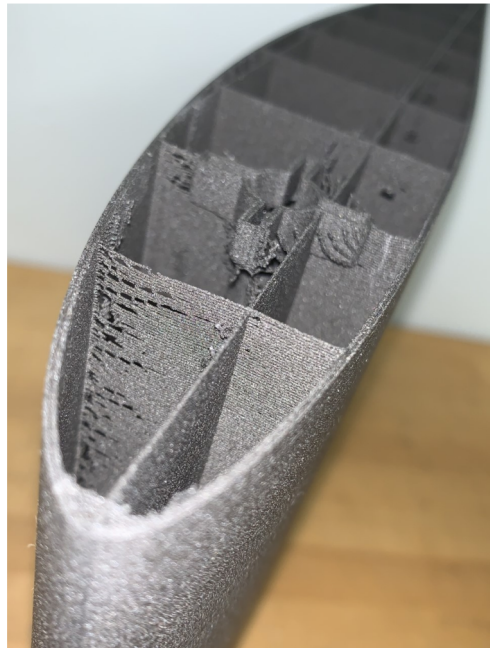
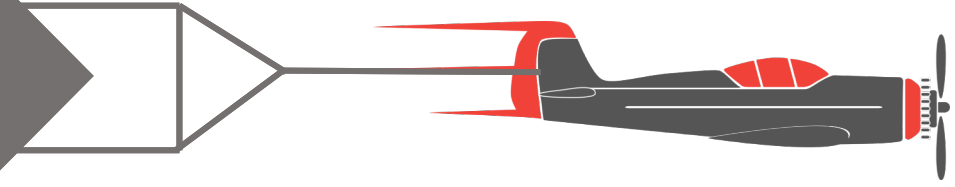

Lauren Chin

Project Brief Summary

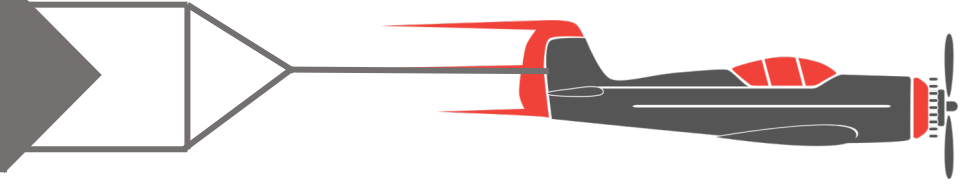

Assembling Methods: Woodworking

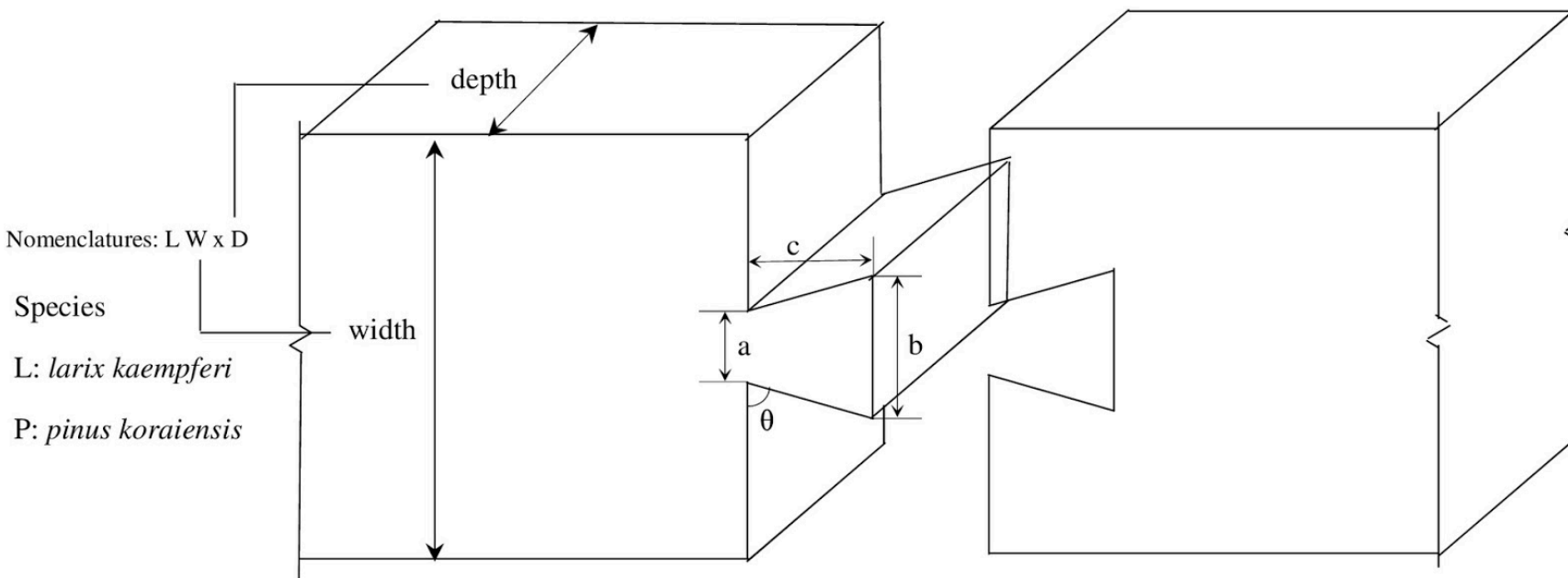
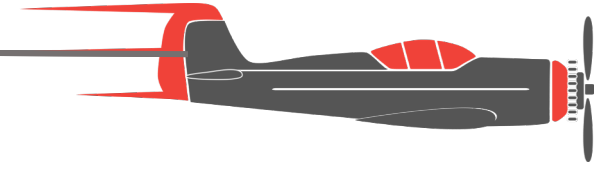

- The Dove Tail Connection
 - Consists of a male and female part
 - Prevents movement perpendicular to the connection
 - Prevents rotational movement

Lauren Chin

Project Brief Summary

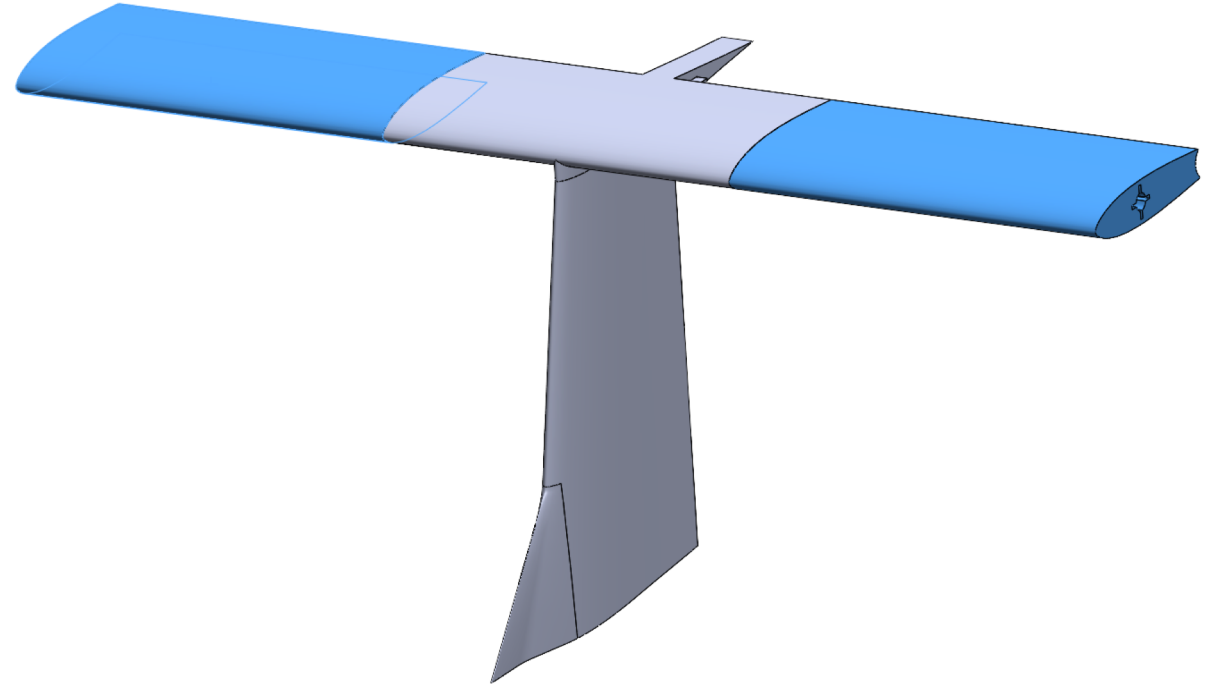
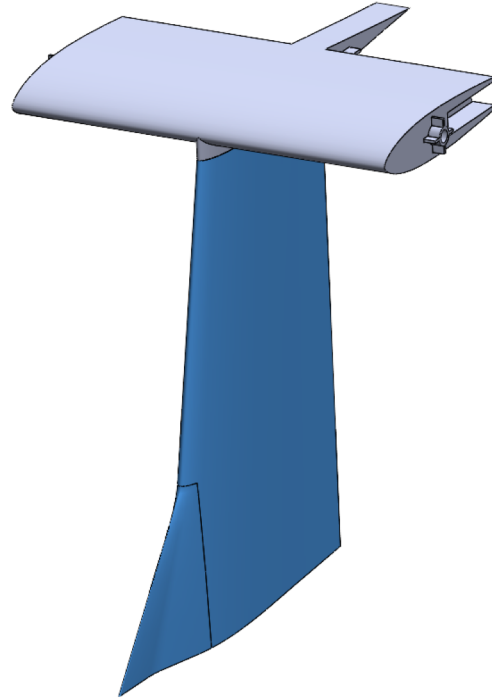
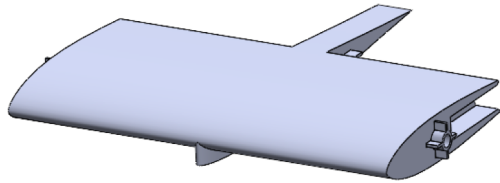
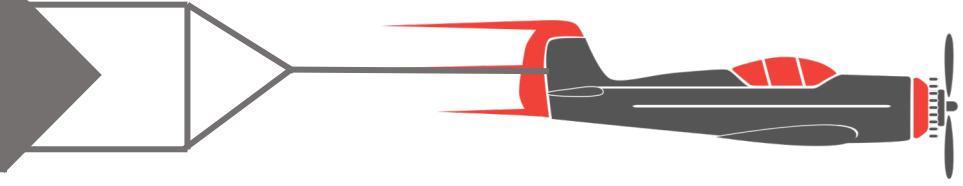

Project Brief Summary

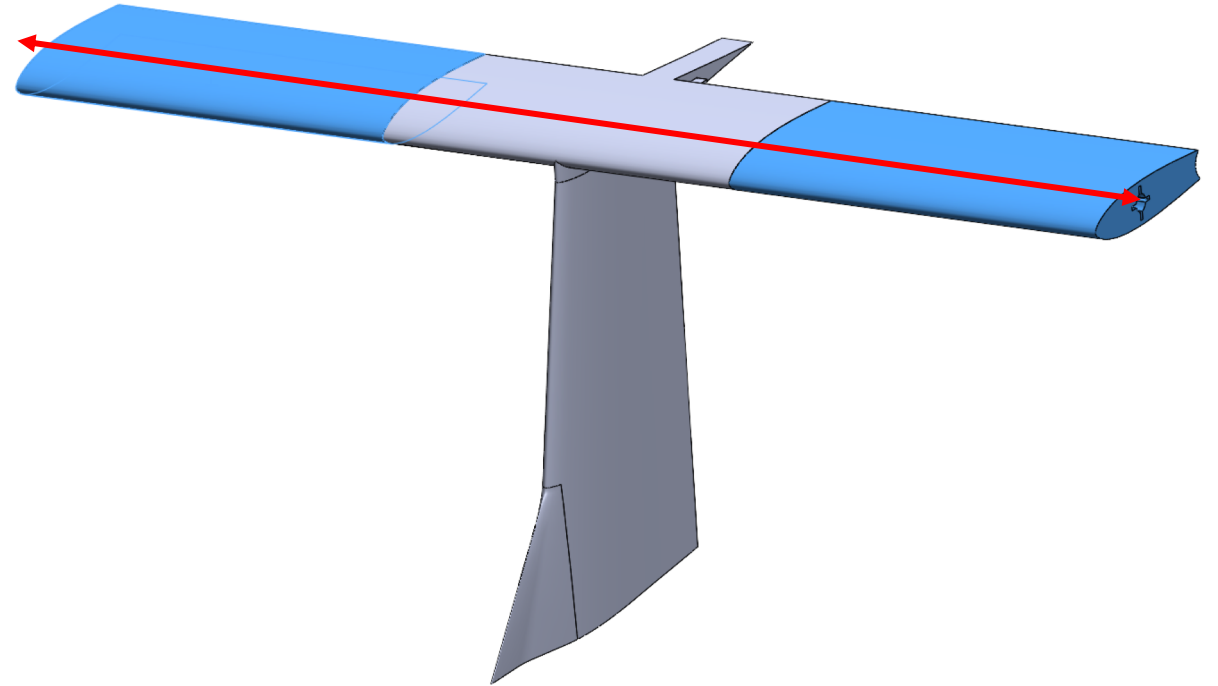
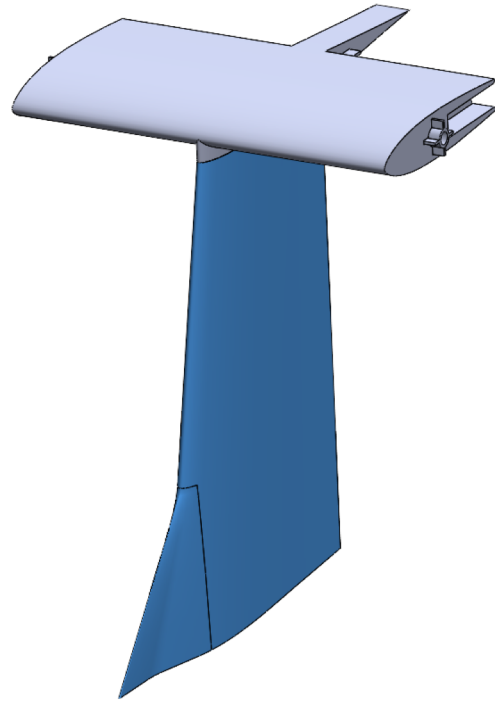
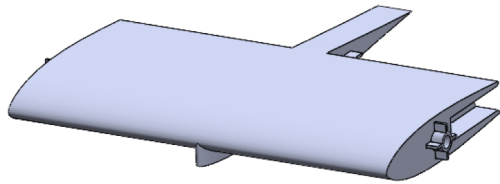
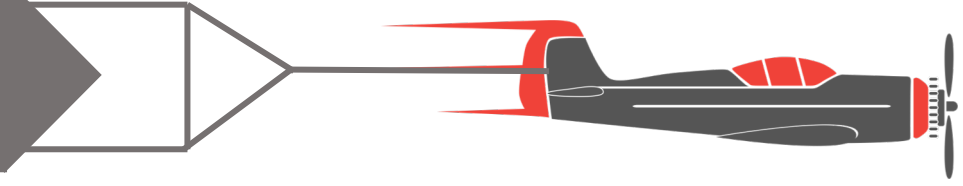

Project Brief Summary

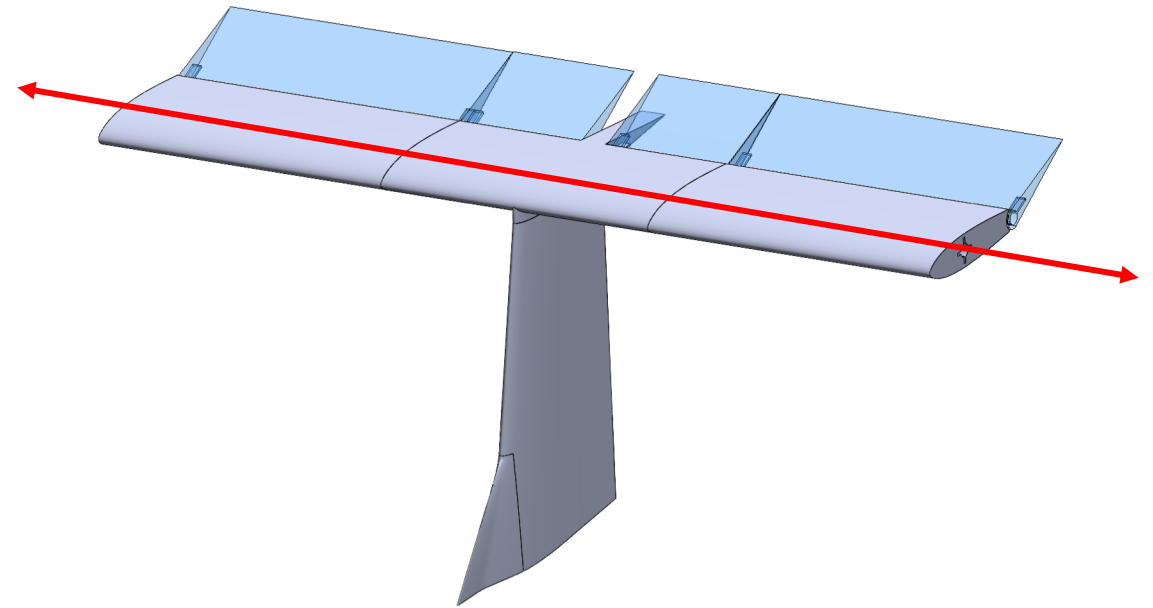
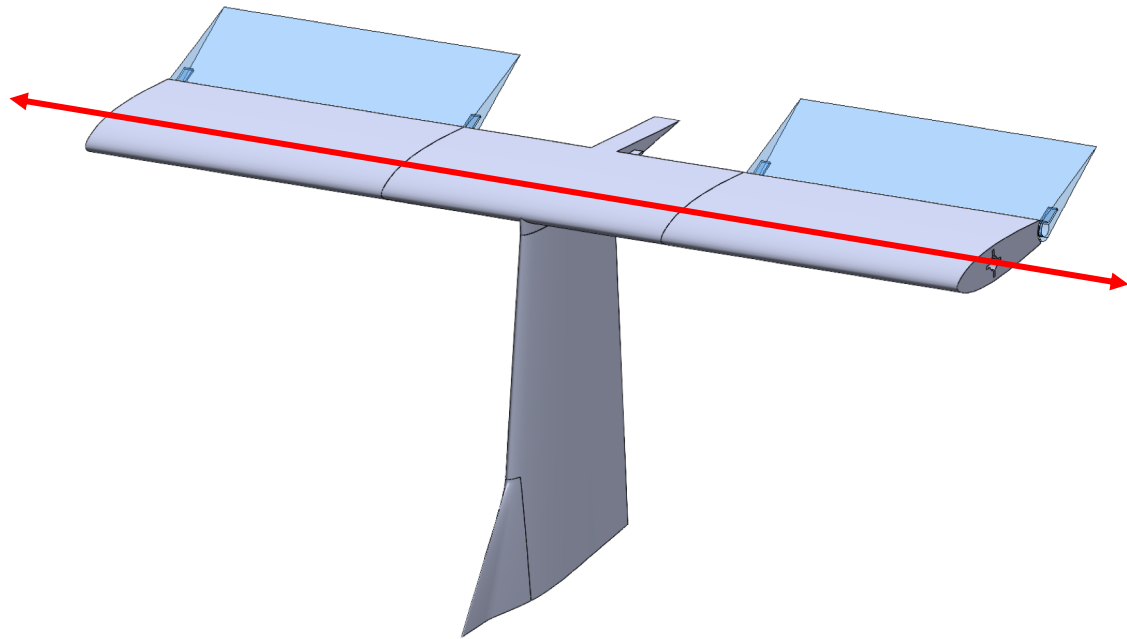
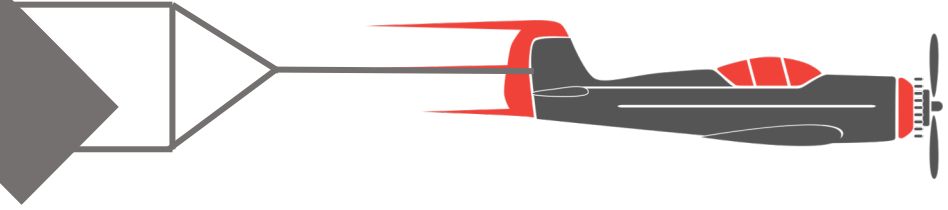

Project Brief Summary

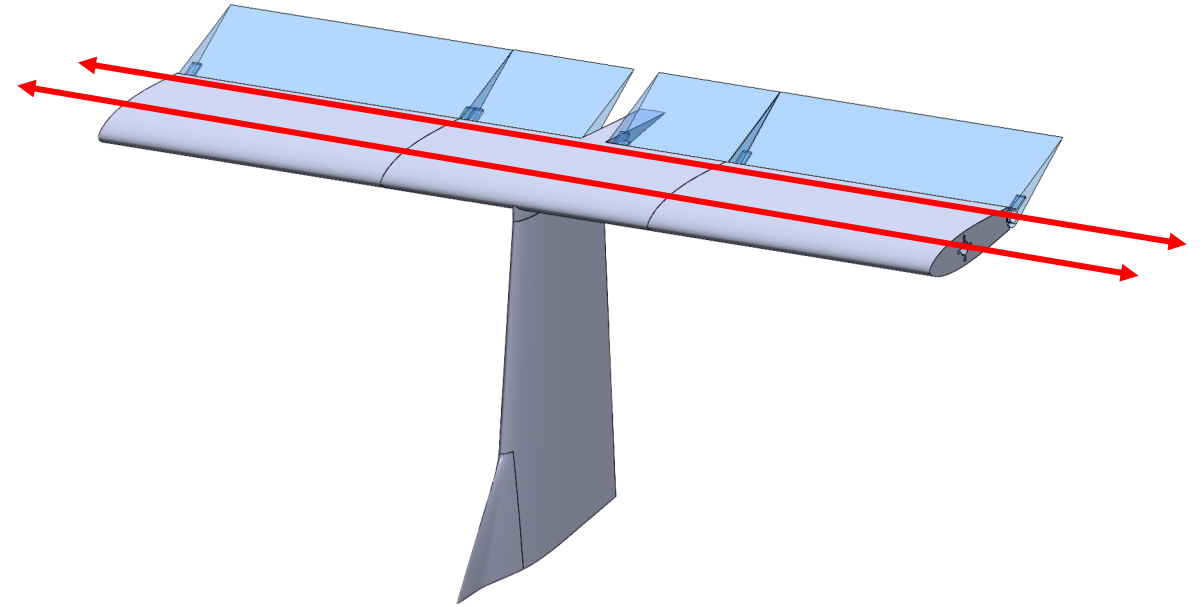
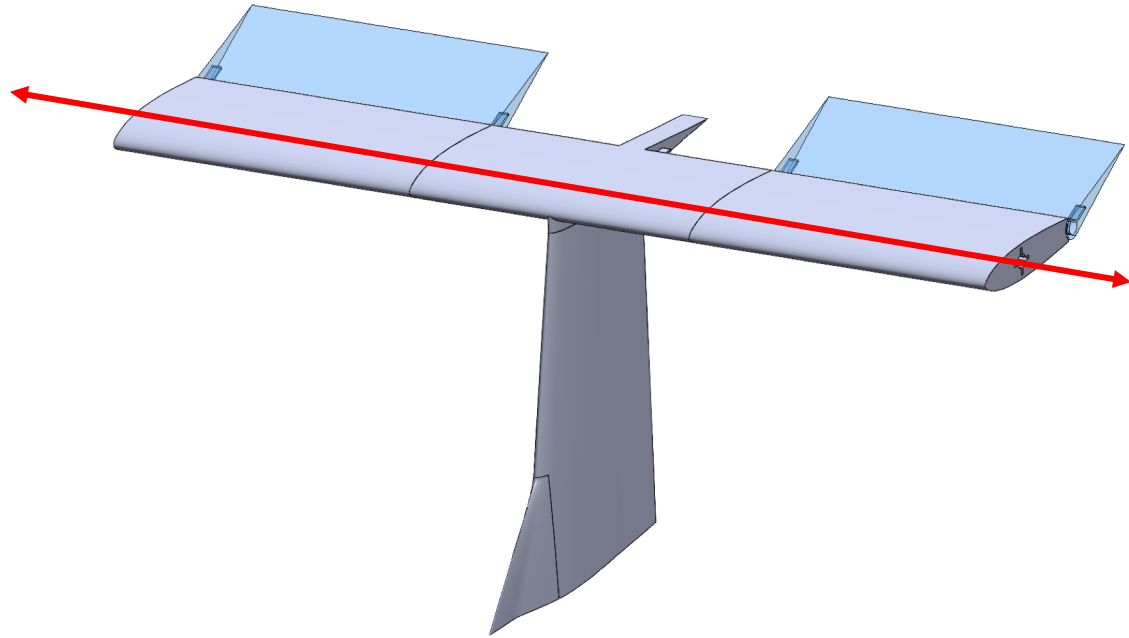
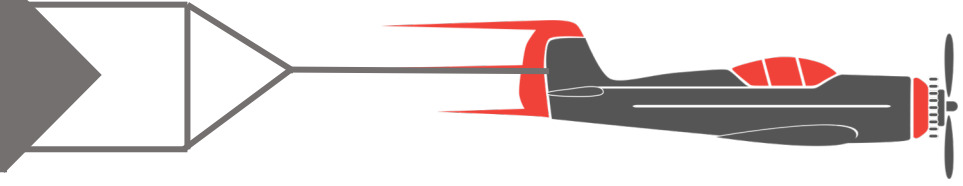

Fall Semester Timeline

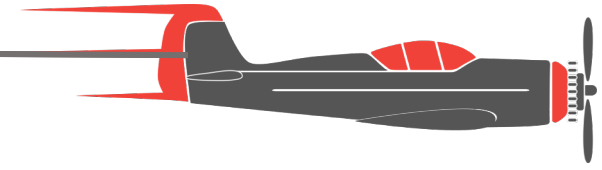

Preliminary Research

Concept Generation

Concept Selection

Preliminary Research												
						Concept Generation						
						Concept Selection						
Aug 30- Sept 5	Sept 6-12	Sept 13 - 19	Sept 20-26	Sept 27- Oct 3	Oct 4-10	Oct 11- 17	Oct 18-24	Oct 25-31	Nov 1-7	Nov 8-14	Nov 18-21	Nov 22 -28
Sep-20			Oct-20			Nov-20						



Winter & Spring Semester Timeline

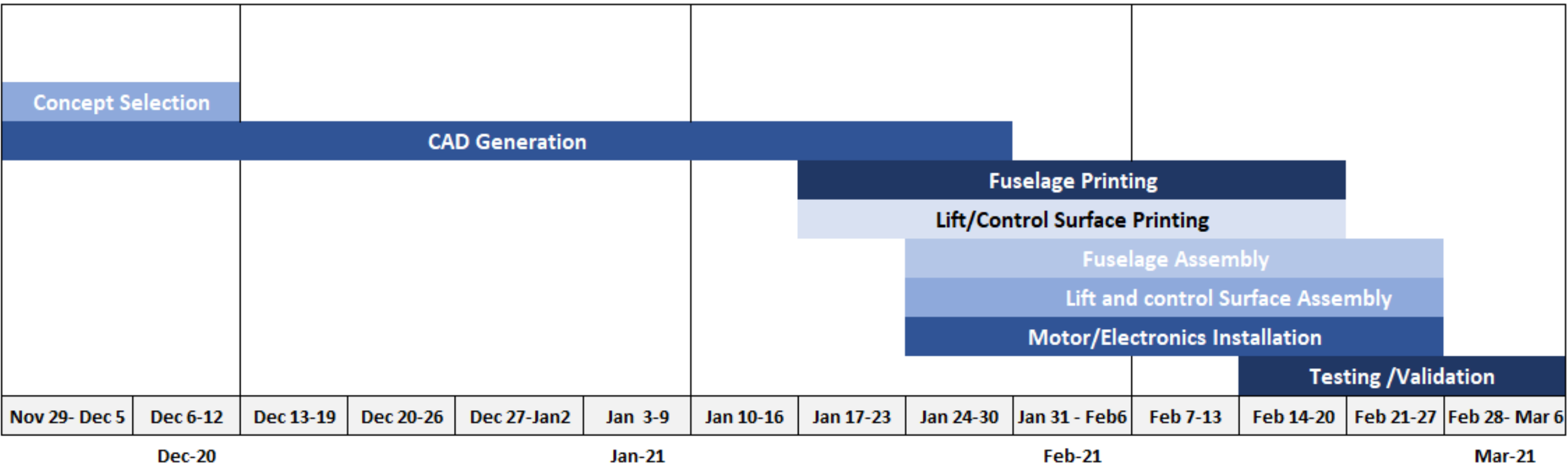
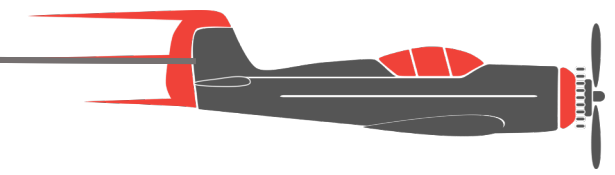

Jacob Pifer

Functional Decomposition

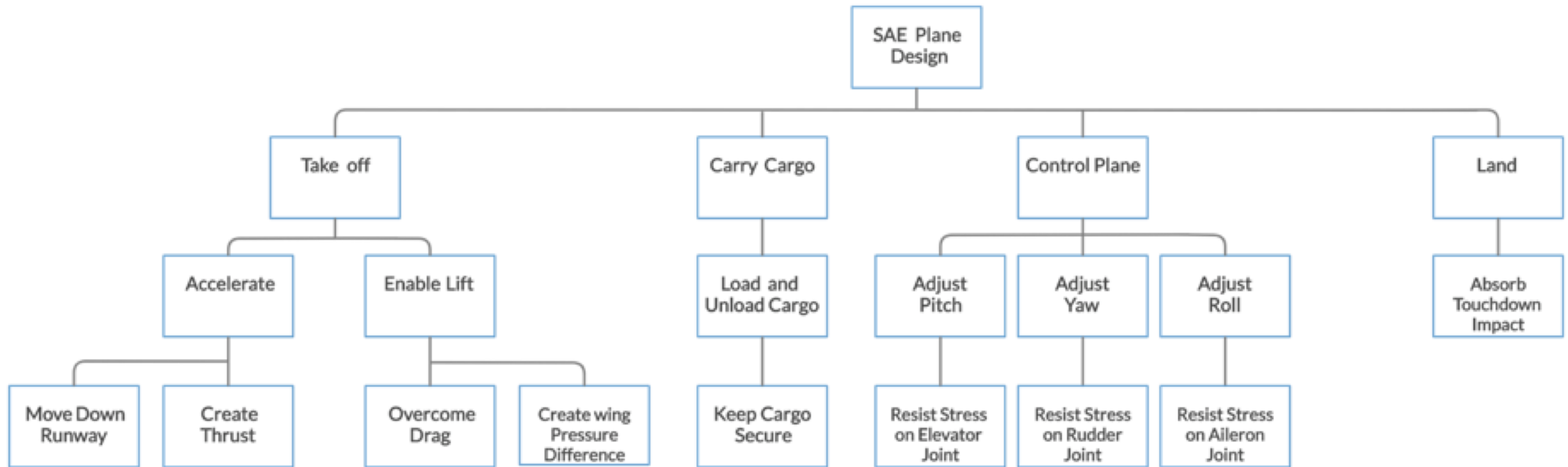

Takeoff

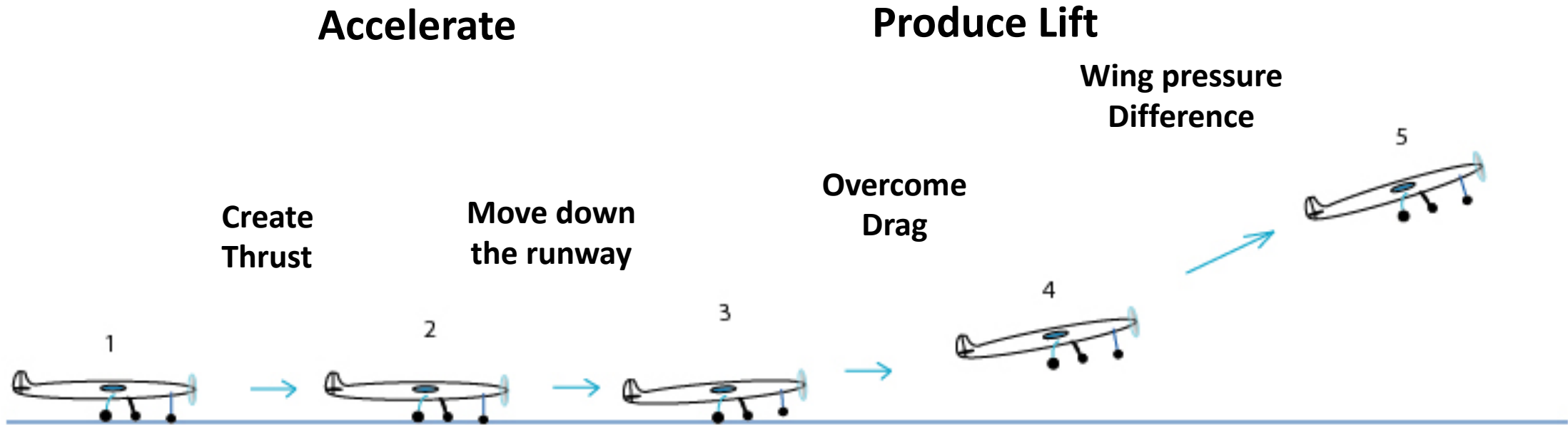

Control Plane

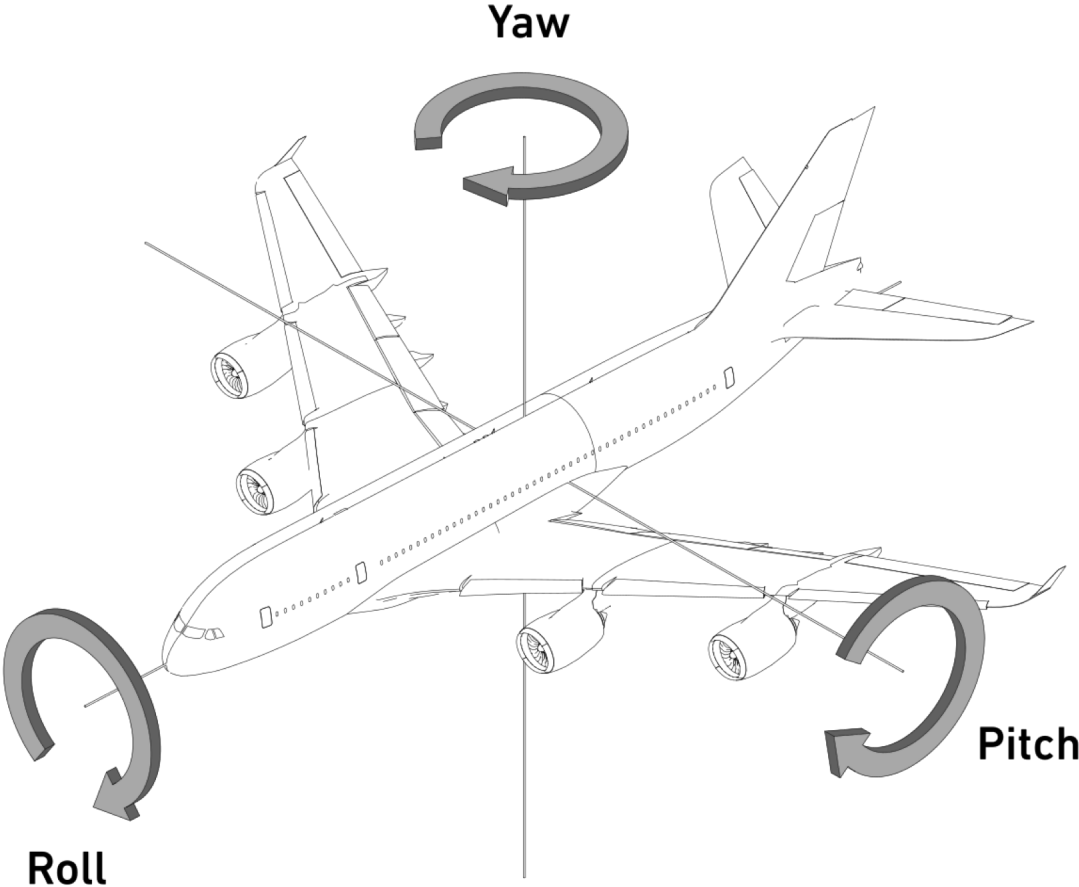

Landing

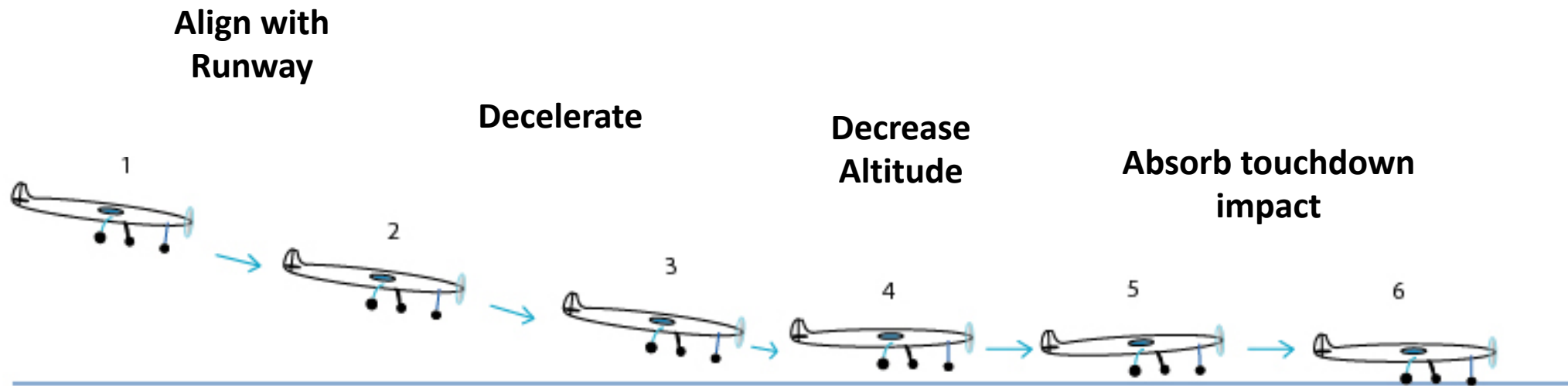

Stress Applied Perpendicular to Filament Layers

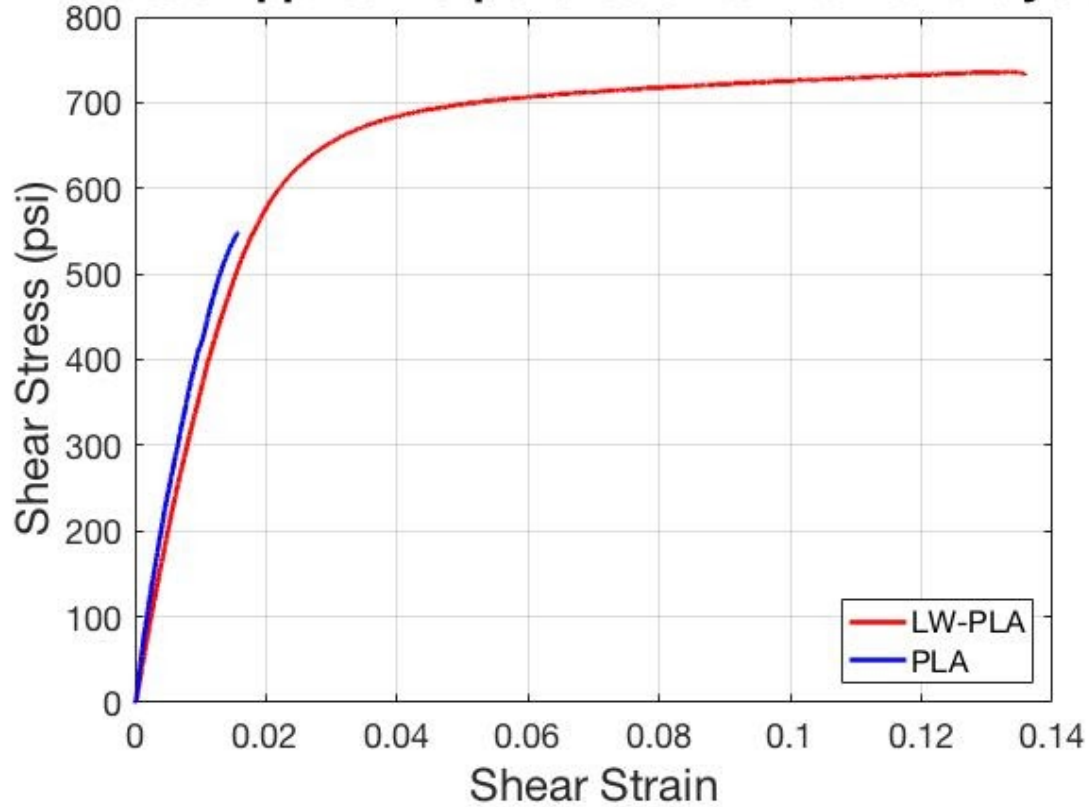

PLA failure stress: 412 psi
LW-PLA failure stress: 552 psi

Stress Applied Parallel to Filament Layers

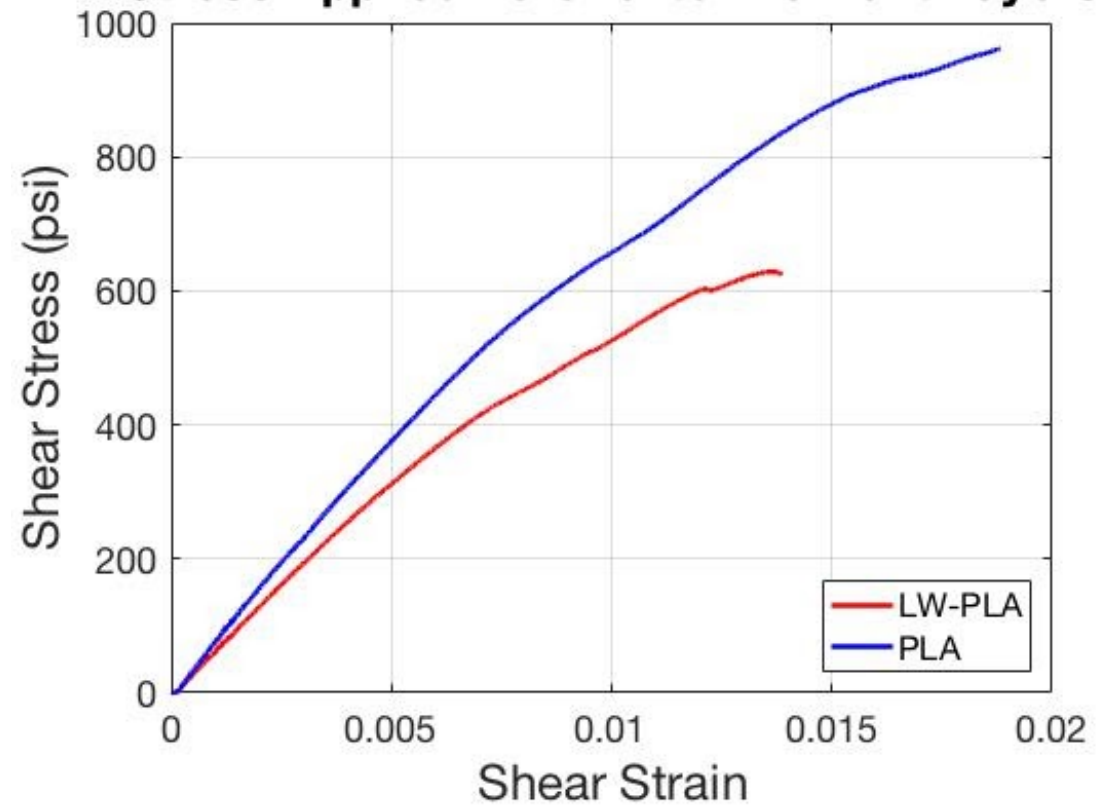

PLA failure stress: 721 psi
LW-PLA failure stress: 471 psi

PLA

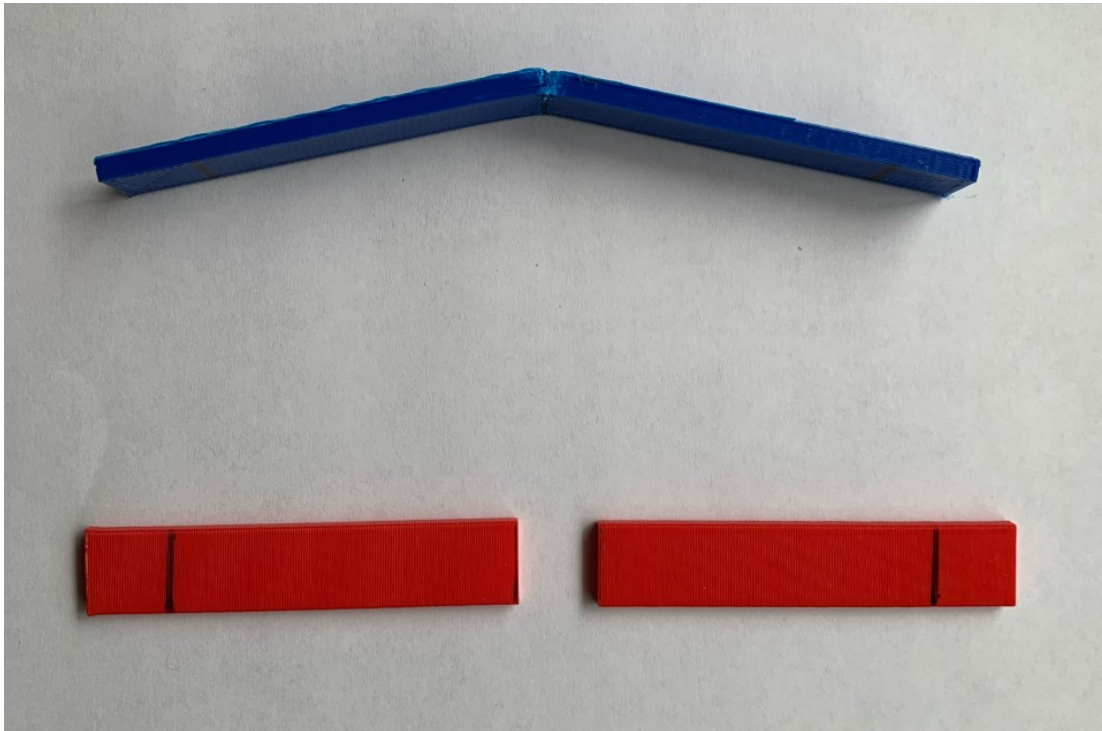

Stress Perpendicular to layering direction: 3,360 psi
Stress Parallel to layering direction: 8,350 psi

LW-PLA



Stress Perpendicular to layering direction: 3,380 psi
Stress Parallel to layering direction: 6,120 psi

Dove Tail Male Construction

- Dimensions:
 - Minimum thickness: 0.5 inches
 - Maximum thickness: 1 inch
 - Length: 5.25 inches
- Characteristics
 - Follows curvature of the airfoil
 - Edges are rounded

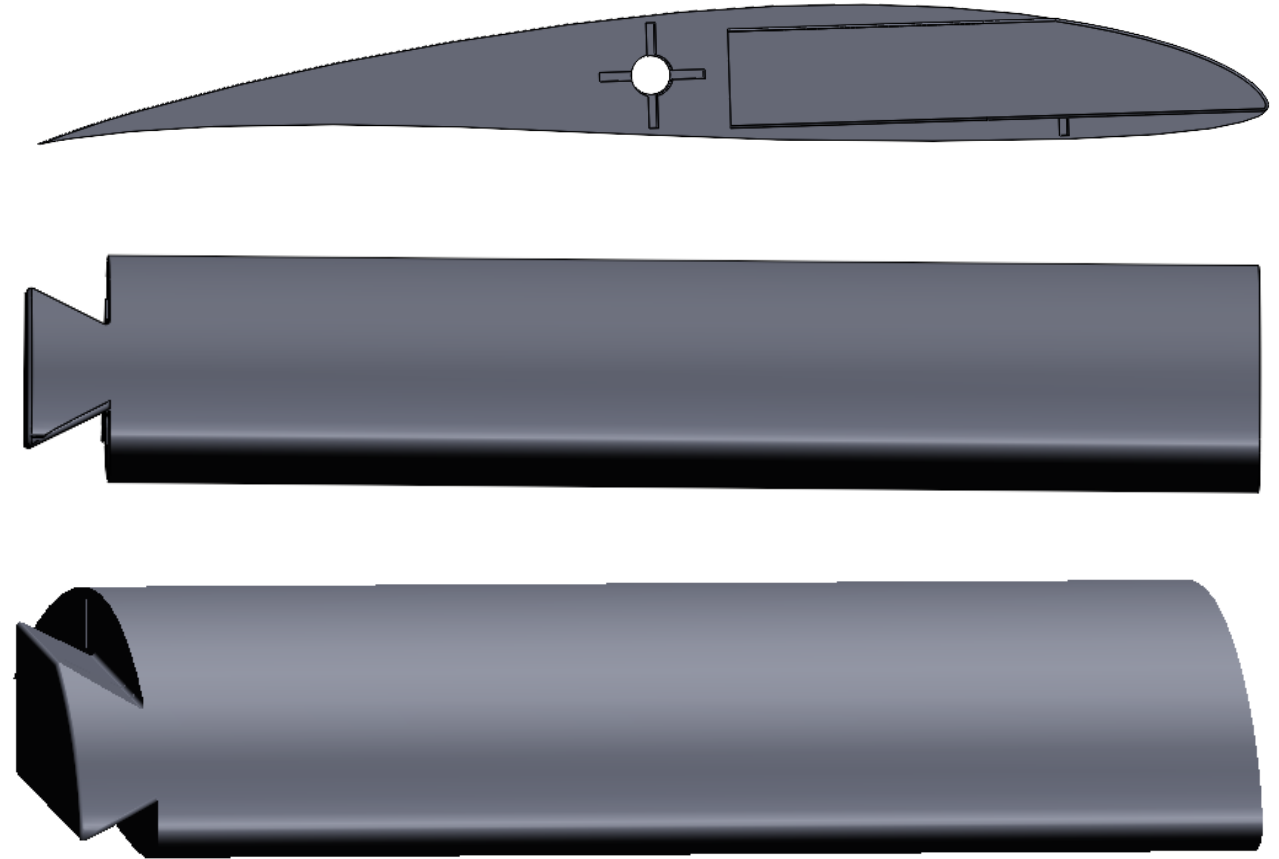

Dove Tail Female Construction

➤ Dimensions:

- Minimum opening: 0.5001 inches
- Maximum thickness: 1.001 inch
- Length: 5.25 inches

➤ Characteristics

- Follows curvature of the airfoil
- Edges are rounded

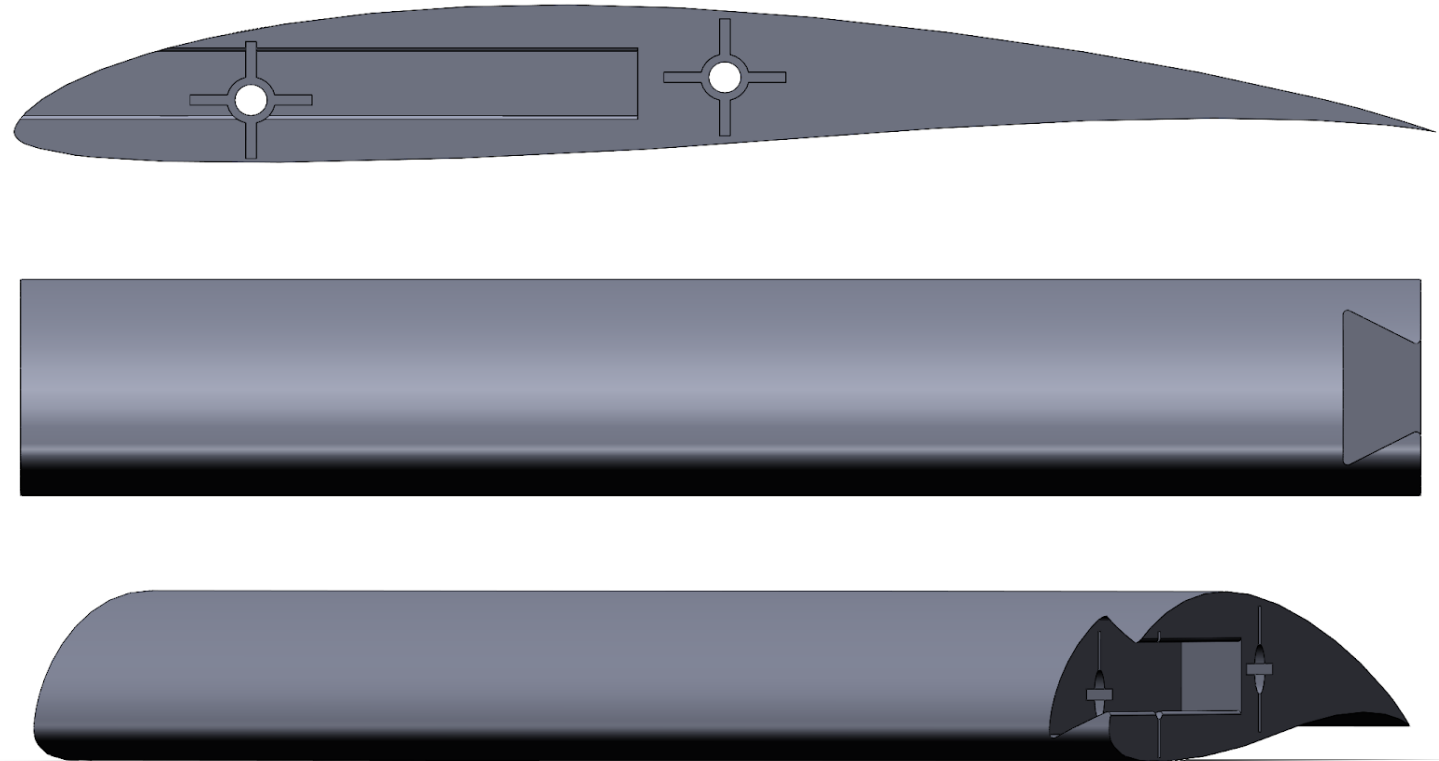

Canard Dimensions

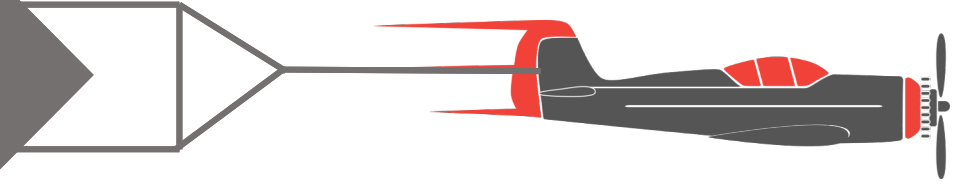

12"

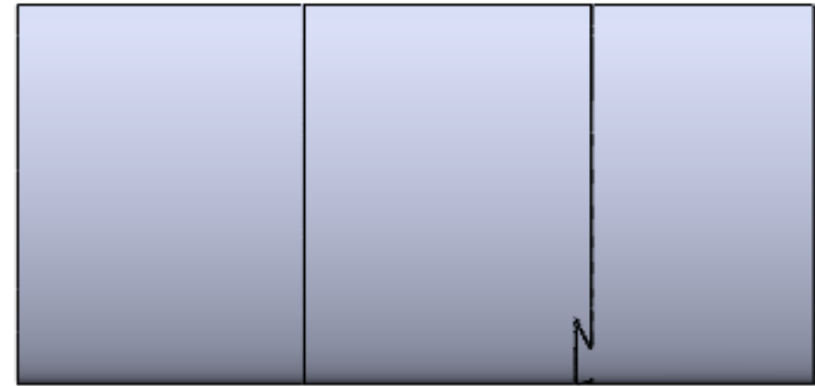

Lauren Chin

Canard Dimensions

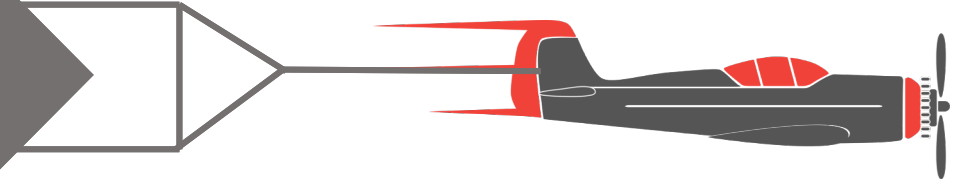

25"

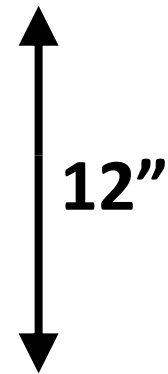

12"

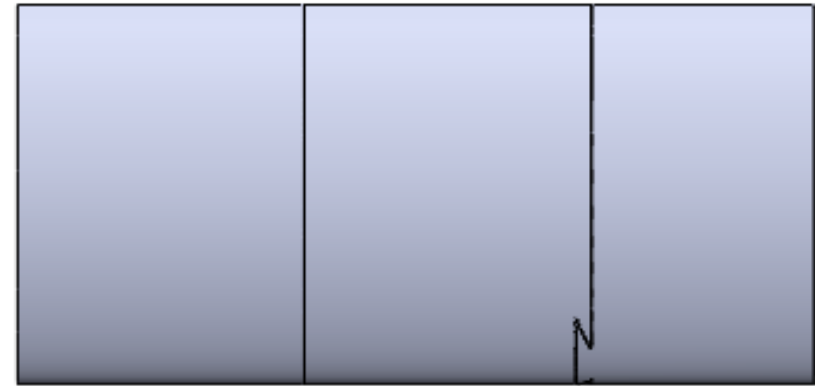

25"

Lauren Chin

Canard Dimensions

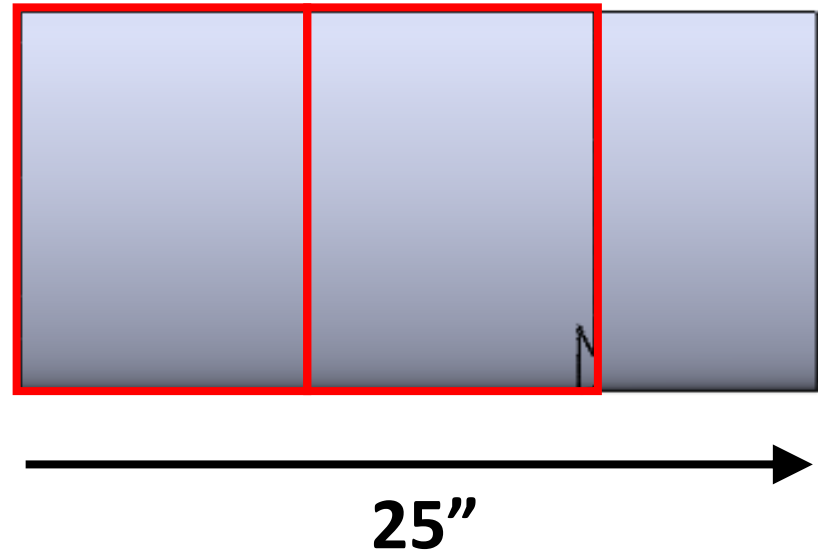
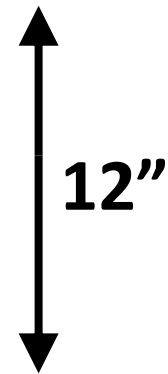
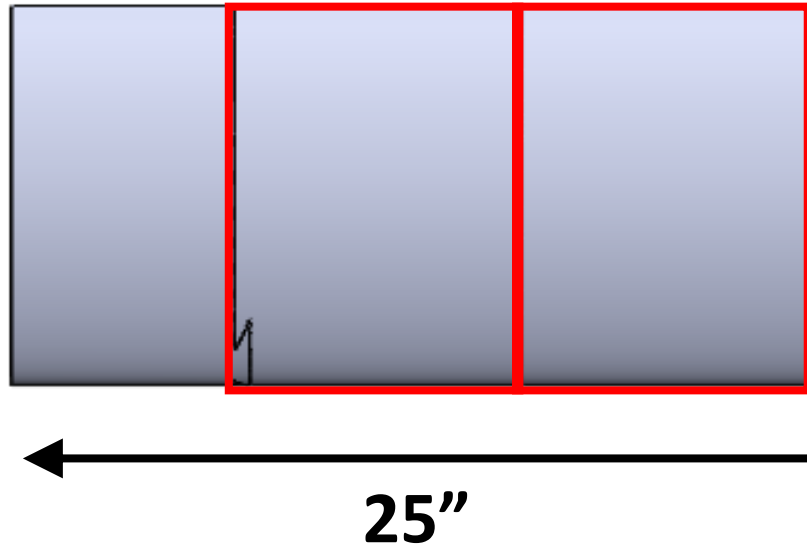
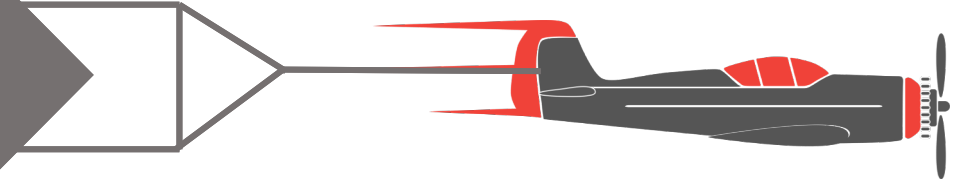

Lauren Chin

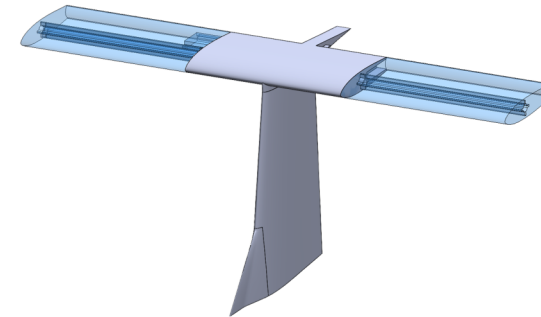
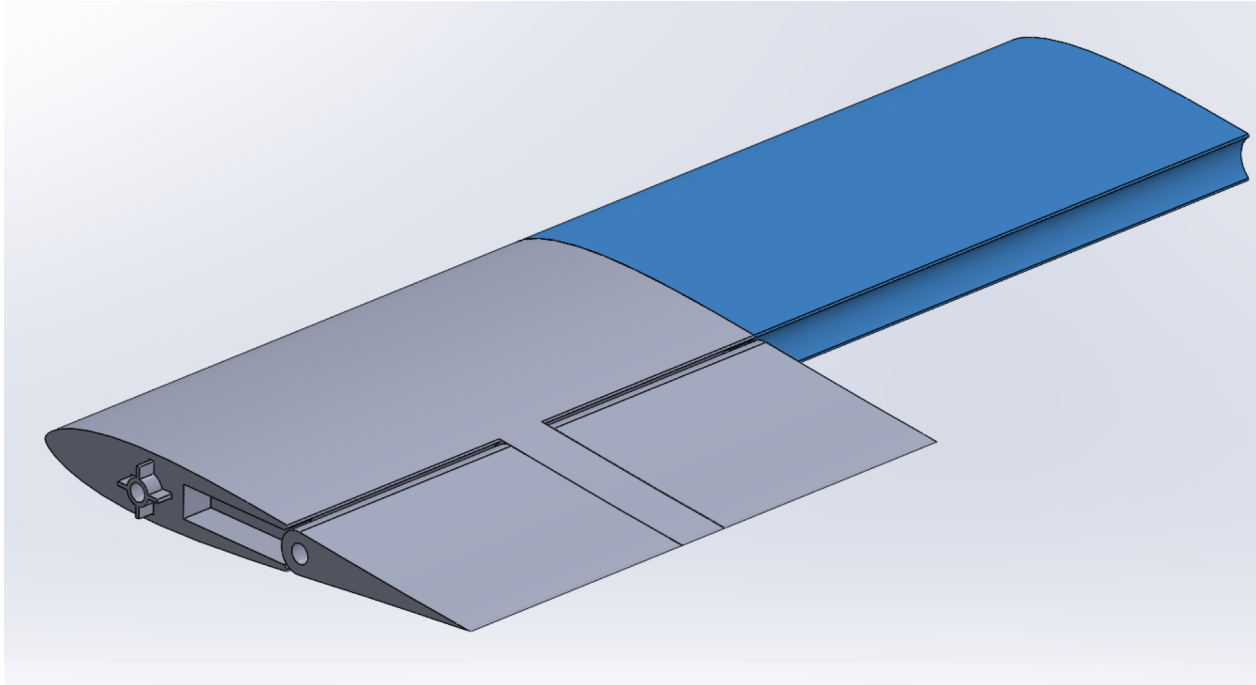

Project Brief Summary

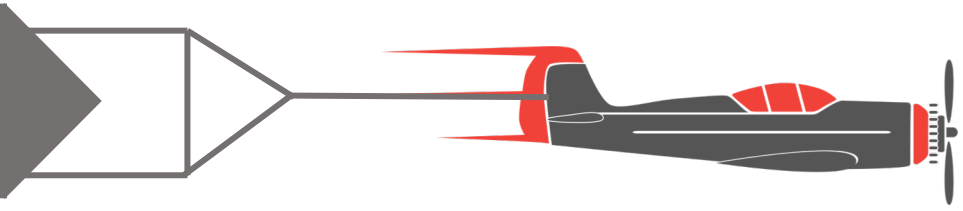

- Dimensions:
 - Minimum thickness: 0.5 inches
 - Maximum thickness: 1 inch
 - Length: 5.25 inches
- Characteristics
 - Follows curvature of the airfoil
 - Edges are rounded

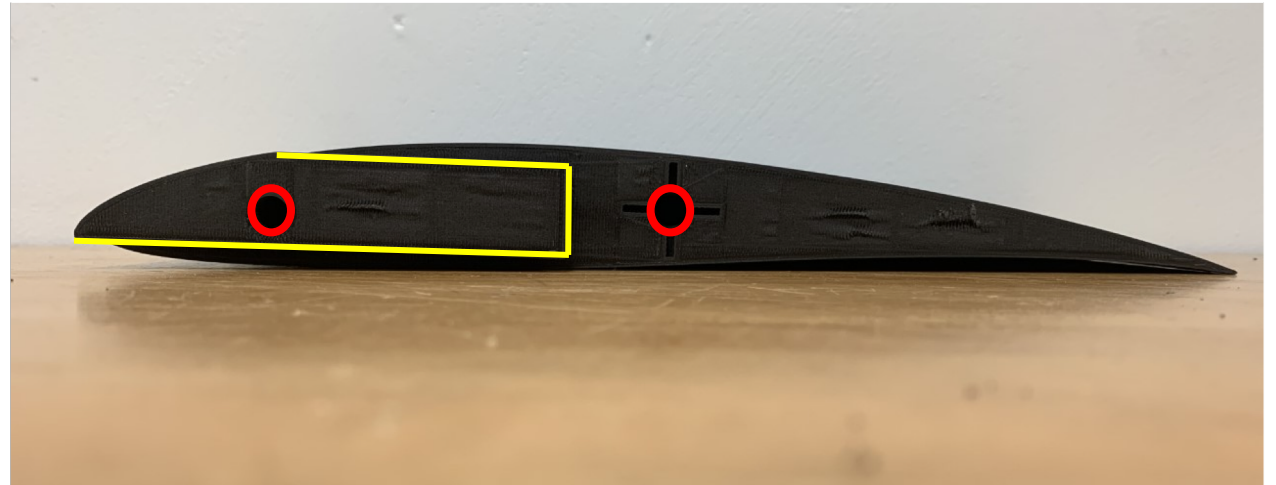

Project Brief Summary

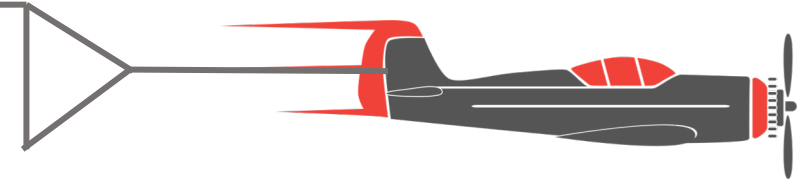

- Dimensions:
 - Minimum opening: 0.5001 inches
 - Maximum thickness: 1.001 inch
 - Length: 5.25 inches
- Characteristics
 - Follows curvature of the airfoil
 - Edges are rounded

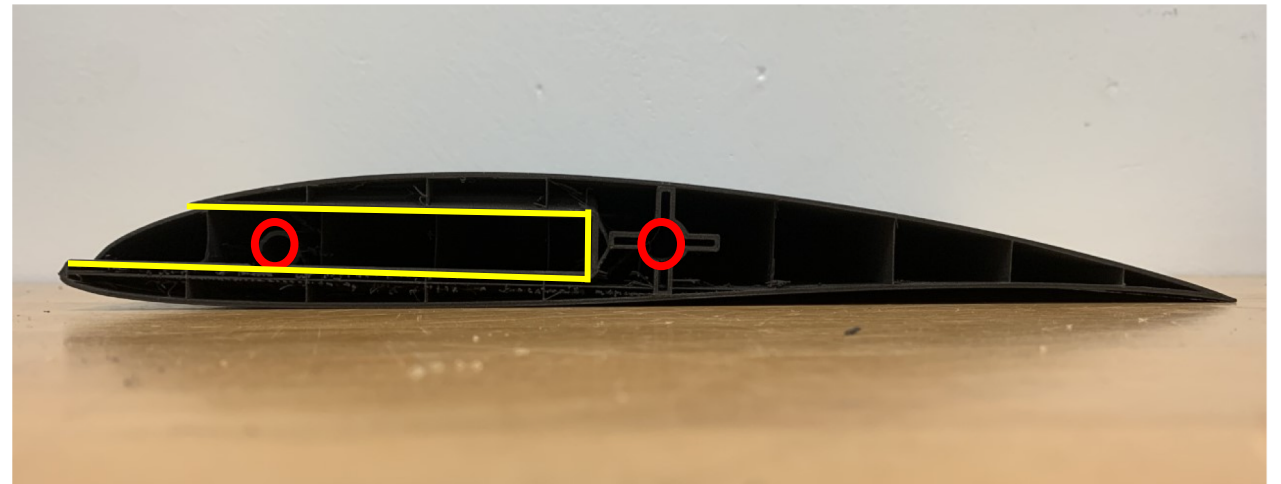

Project Brief Summary

