

# NASA Nuclear Canister in Space



Mac Borngesser | Braden Dukes | Brian McGough | Jaxon Stadelnikas

Team 515

# Team Introductions



McAnarney Borngesser  
*Aeronautics Engineer*



Braden Dukes  
*Materials Engineer*



Brian McGough  
*Aeronautics Engineer*



Jaxon Stadelnikas  
*Aeronautics Engineer*

Jaxon Stadelnikas



# Sponsor and Advisor



Engineering Sponsor

Marvin Barnes

*NASA Marshall Space Flight Center*



Academic Advisor

Eric Hellstrom, Ph.D.

*FAMU-FSU College of Engineering*

Jaxon Stadelnikas

# Objective

The objective of the project is to develop and test a canister to go into Big BUSTER to test nuclear fuel compounds for thermal nuclear propulsion systems in the Transient Reactor (TREAT).



Jaxon Stadelnikas

# Project Background

NASA plans on going to Mars

Nuclear Thermal Propulsion engines are very efficient

Further research can improve efficiency of NTP engines

Develop a component for Big BUSTER to test different fuels for NTP engines.

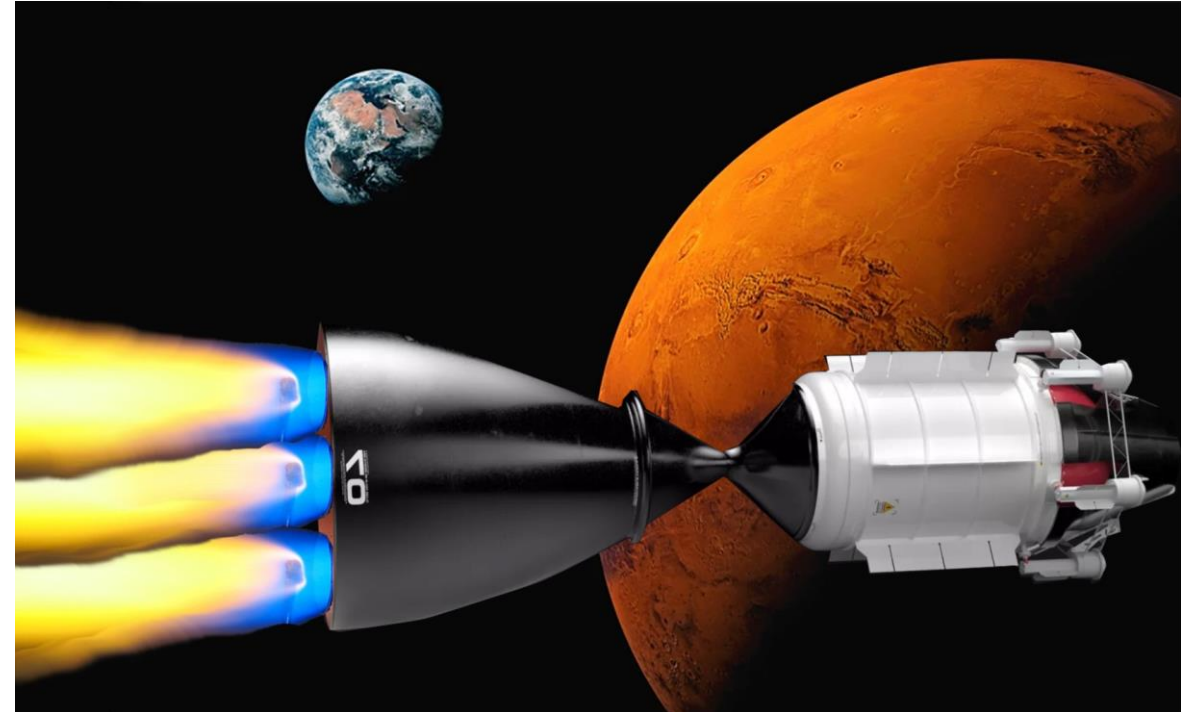

Jaxon Stadelnikas

# Assumptions

Big BUSTER will function according to the specifications given by NASA

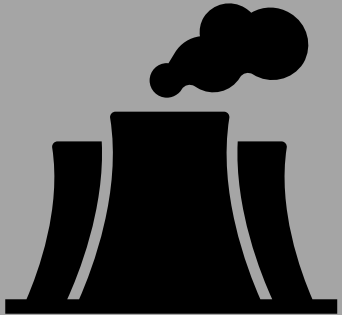

Weight will not be a constraining factor

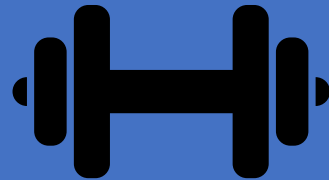

Temperature range will not exceed 3000K



Radiation containment is done by Big BUSTER, not the canister

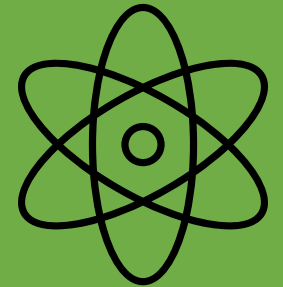

Jaxon Stadelnikas

# Key Goals

Temperature  
Resistant

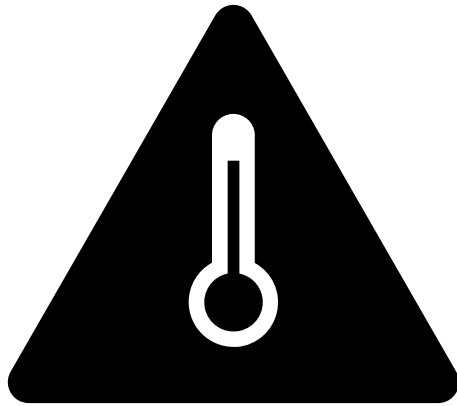

Resist Effects of  
Radiation on  
the Canister

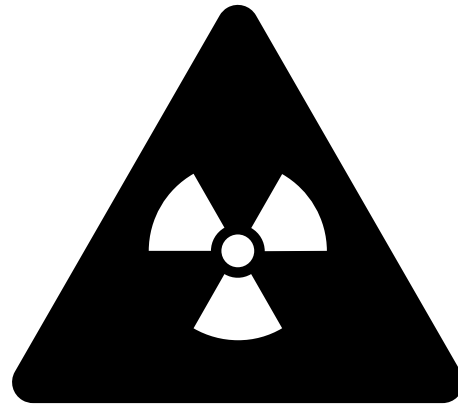

Reusability

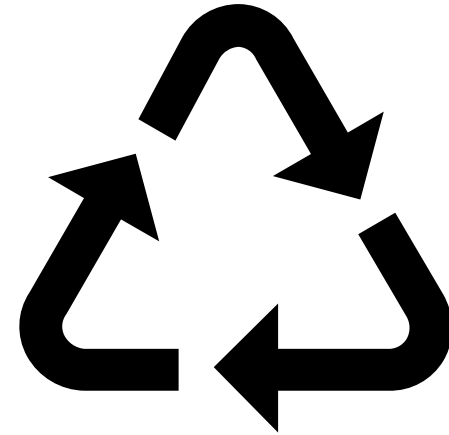

Jaxon Stadelnikas

# Functional Decomposition

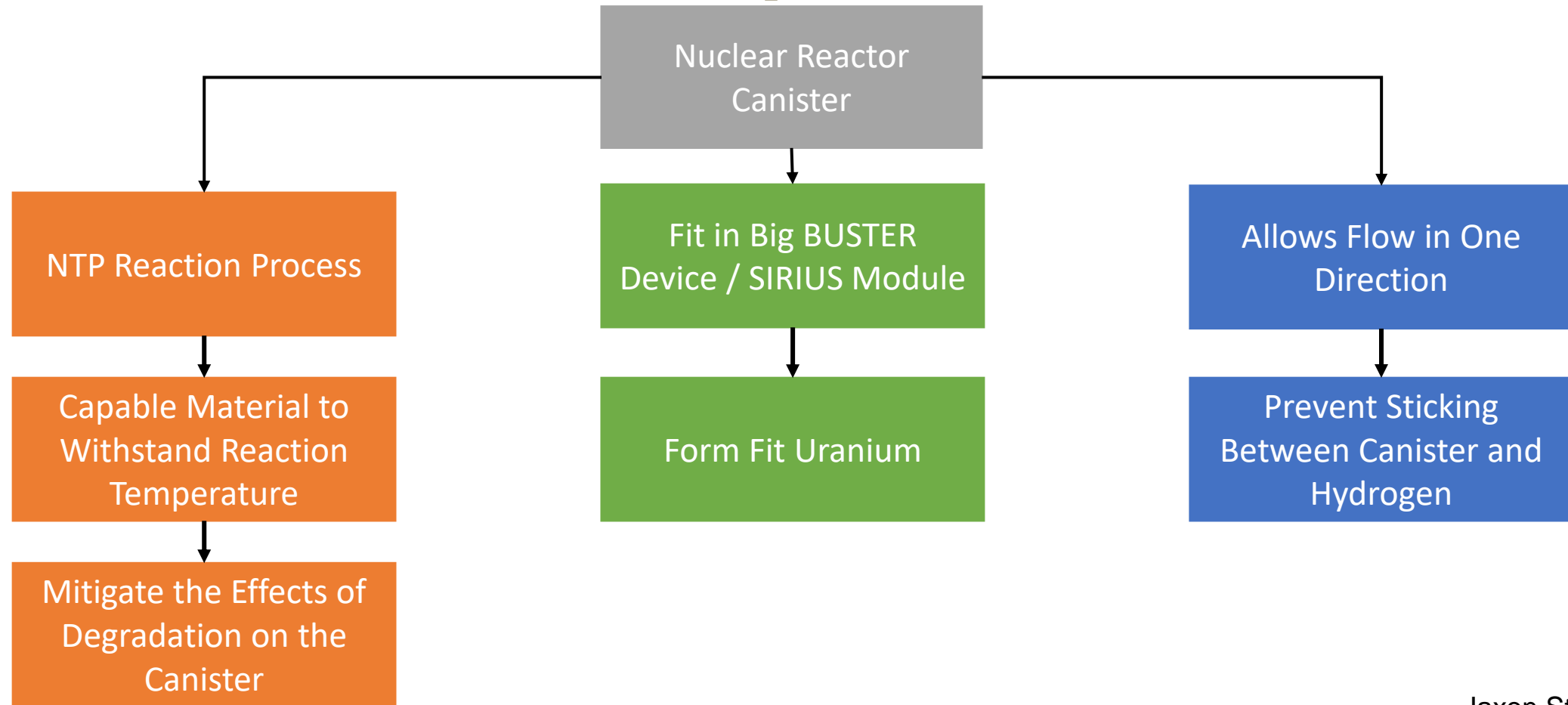

Jaxon Stadelnikas



# NTP Reaction Process

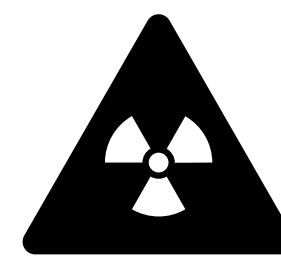

Capable Material to Withstand Reaction Temperature

- 3000 K

Mitigate the Effects of Degradation on the Canister

- Less than 8 GPa increase in hardness

Jaxon Stadelnikas

# Fit in Big BUSTER Device / SIRIUS Module

## Form Fit Uranium

- Marble size reference
  - Volume of  $9.2\text{cm}^3$
  - Mass of 179 g
- Maximum dimensions for the canister is 61 cm length and 8 cm diameter
- Less than  $6 \times 10^{-6} \frac{m}{m^\circ C}$  Thermal expansion rate

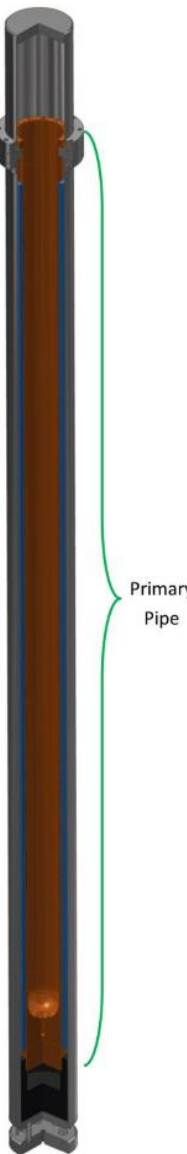

Jaxon Stadelnikas

# Allows Flow in One Direction

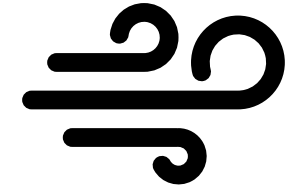

Prevents Hydrogen Propellant from Sticking to the Canister

- Less than  $6 \times 10^{-6} \frac{m}{m^{\circ}C}$  Thermal expansion rate
- Hydrogen flow rate of  $20 \frac{g}{sec}$

Jaxon Stadelnikas

# Concept Generation

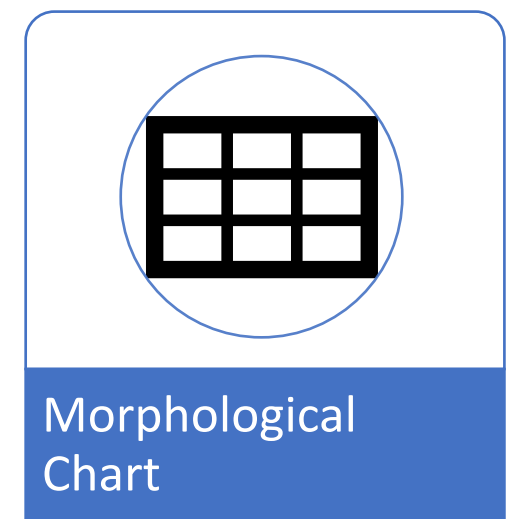
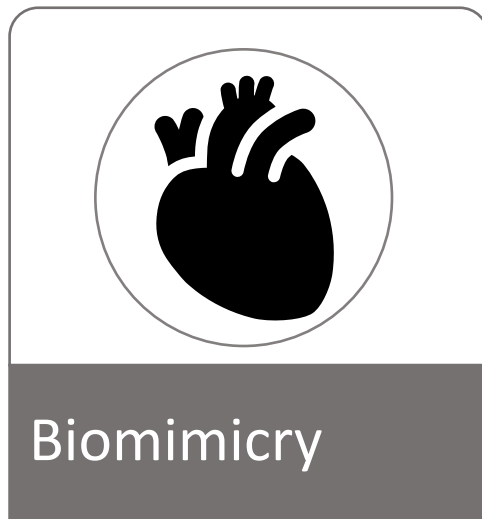

Mac Borngesser



# First High-Fidelity Design

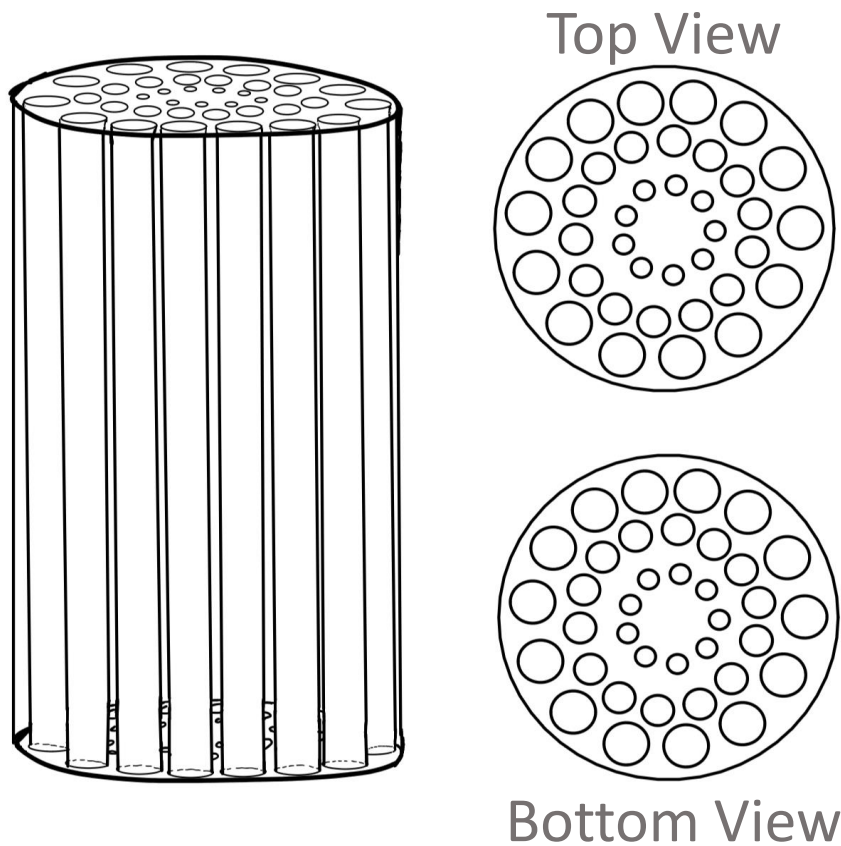

Base metal of Tungsten

Straight path for hydrogen to flow

# Second High-Fidelity Design

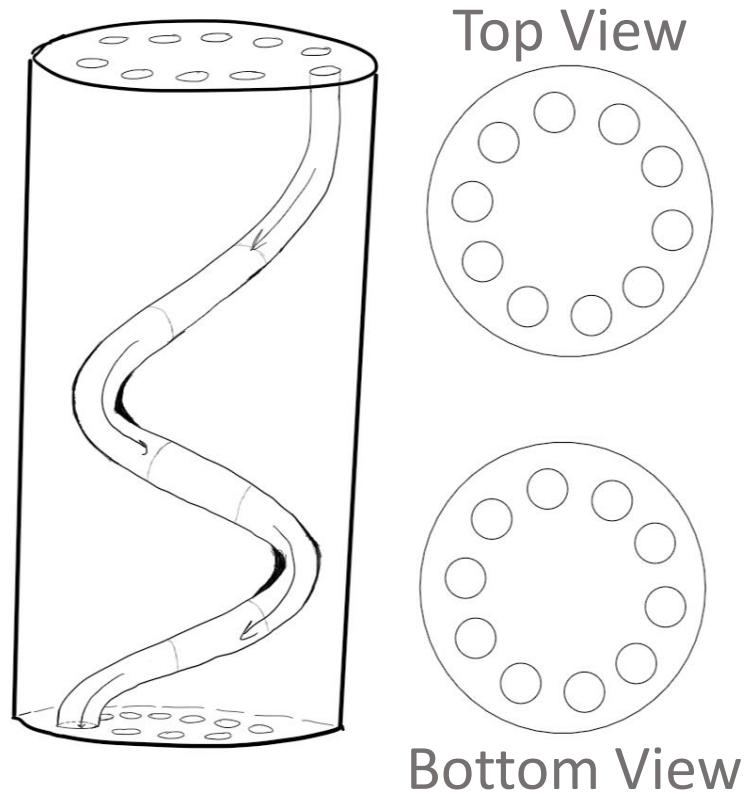

Base metal of Tungsten

Spiral path for hydrogen to flow

Mac Borngesser

# Third High-Fidelity Design

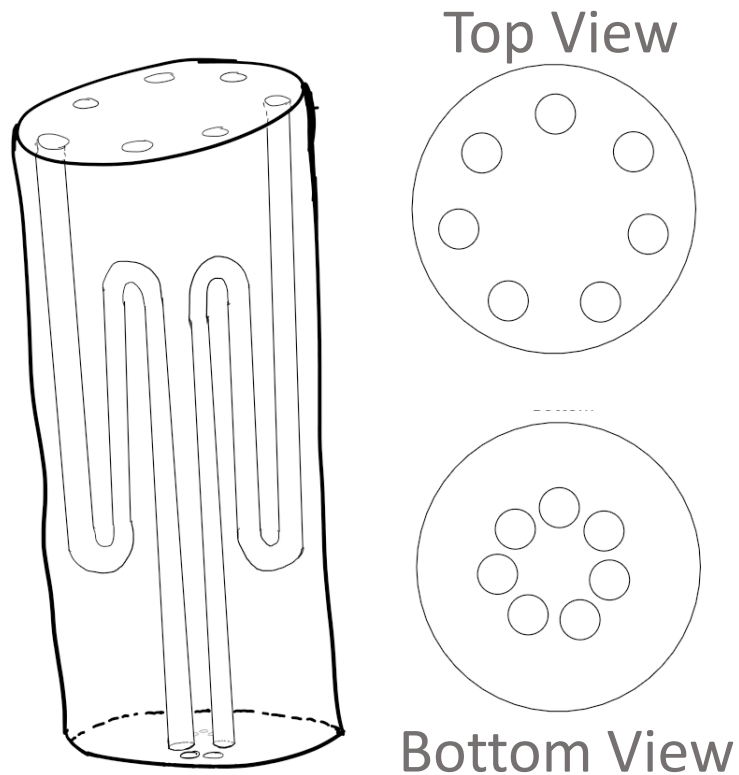

Base metal of Tungsten

Triple pass path for hydrogen to flow

Mac Borngesser

# Concept Selection

Selected concept: High-fidelity concept #1

Tungsten Base Metal Straight Paths

- Highest ranking among Pugh charts
- Best suited for the project
- Integrates well with existing design



Mac Borngesser



# Proposed Design

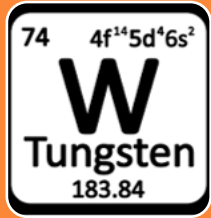

99.99% Pure  
Tungsten



Hydrogen  
Propellant



Uranium Fueled

# Experimental Design

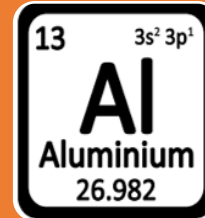

Aluminum 6061

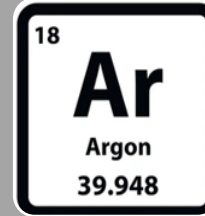

Argon "Propellant"



Heating Element  
"Fission Product"

Mac Borngesser

# Prototype

## 7in tall 3-D printed "mock" canister

- 3.81cm (1.5in) diameter
- 28 flow channels
  - 0.316cm (0.125in) diameter flow channels

## Aluminum 6061 14in machined canister

- 7.62cm (3in) diameter
- Heating element
- 28 flow channels
  - 0.635cm (0.25in) diameter flow channels
- Lundy Enterprise



Mac Borngesser

# Prototype CAD Models

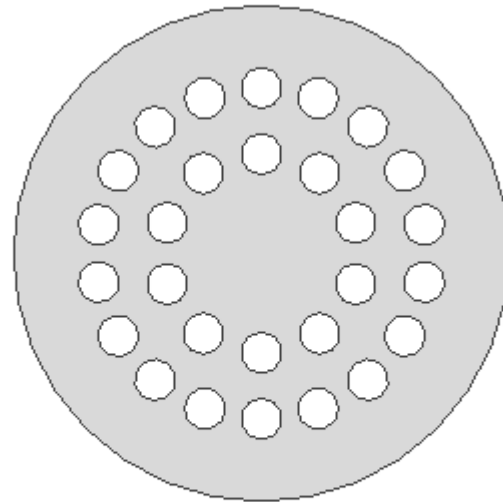
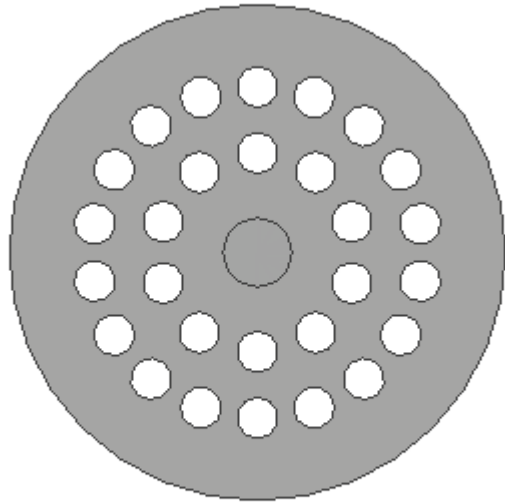

Mac Borngesser

# Prototype CAD Assembly

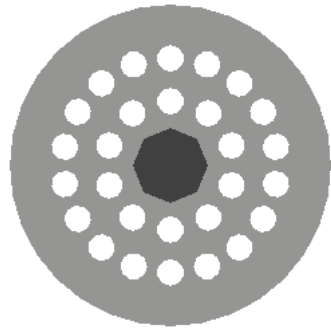

Mac Borngesser



# Canister Testing

## Thermocouples

- Measure the heat on each end of canister
- Measure the heat transfer of the canister

## Regulators

- Control the flow of argon
- Control the flow rate

## Flexible Tubing

- Required to connect argon to canister

Mac Borngesser

# Future Work

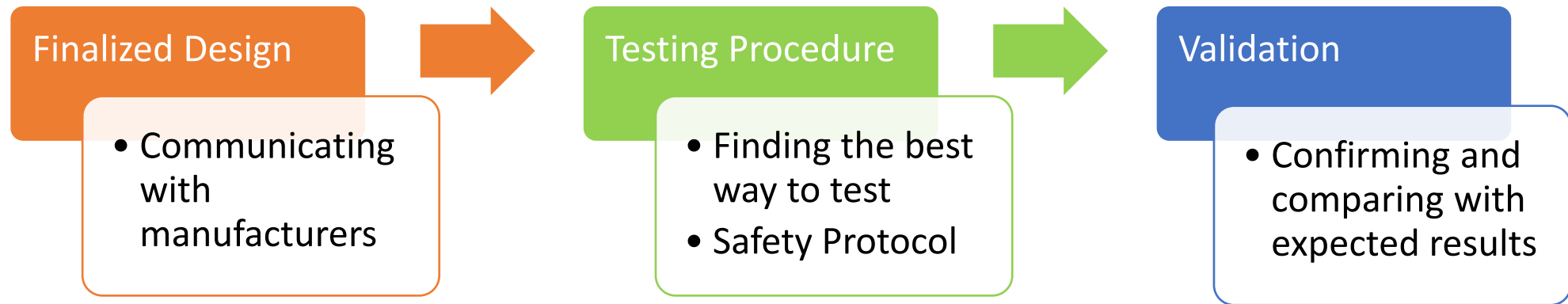

Mac Borngesser

# NASA Nuclear Canister in Space



Mac Borngesser | Braden Dukes | Brian McGough | Jaxon Stadelnikas

Team 515