

# Rankine Cycle

## *Experiment 4*

### 1 Objective

The purpose of this experiment is to observe a model steam power plant in operation. We will conduct an experiment on the **Rankine Cyclor** provided by Turbine Technologies. We will study the Rankine Cyclor System as a whole as well as the details of each component that makes up the system. We will also focus on the thermodynamic analysis of the system and its components in a steady state, steady flow condition.

### 2 Safety Precautions

- **DO NOT operate the Rankine Cyclor without first becoming familiar with the the steps and precautions outlined below (also provided in the Operator's Manual).**
- **DO NOT operate the system unattended.**
- **DO NOT touch any surface on the Cyclor during operation – MOST SURFACES ARE HOT !!!**
- **DO NOT move the system while operating or when the boiler is pressurized.**
- **DO NOT allow the boiler water level to drop below the 1.0 in (2.5 cm) mark on the sight glass.**
- **DO NOT attempt to fill the boiler while the system is pressurized.**
- **DO NOT open the boiler doors while hot. Doing so may cause permanent warping of the boiler cradle.**
- **DO NOT exceed scale readings/limitations on any instrument or gauge.**
- **DO NOT tighten or adjust fittings while the system is under pressure.**
- **DO NOT tap on or scratch the boiler sight glass.**

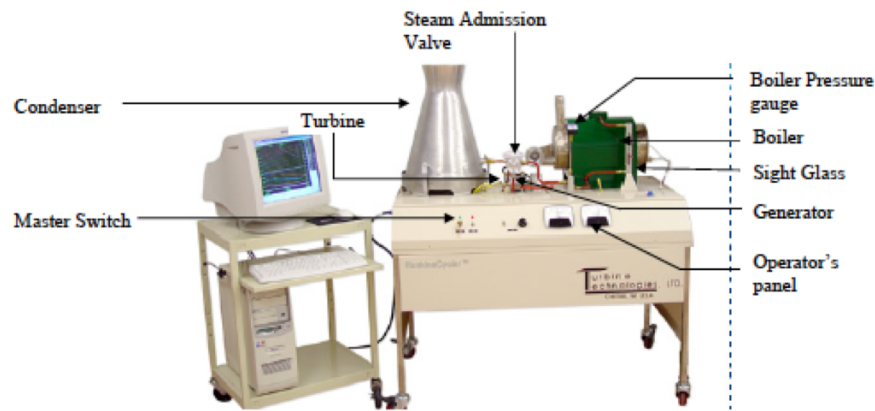

Figure 1: Rankine Cycler by Turbine Technologies

### 3 The Rankine Cycler

Figure 1 shows the Rankine Cycler from Turbine Technologies. Figure 2 and 3 show details of the components, and Fig. 4 provides a schematic of the set-up. The Rankine cycler is an open cycle, where the steam is generated in the boiler by evaporating and superheating of water. The steam passes through a valve where it is throttled to lower pressure and then enters the turbine where it is expanded. The turbine drives the generator; the generator load can be controlled. After expansion in the turbine, the steam is exhausted into the ‘cooling tower’, where part of the steam condenses. Pressure and temperature measurements are taken at the boiler outlet, before the turbine, and after the turbine. This allows us to find important thermodynamic quantities which are essential for the evaluation of the turbine performance.

## 4 Experimental Procedure

### 4.1 Pre-start

*Complete the pre-start procedures per the checklist (1-17) given below. The checklist establishes that all systems are ready for operation and that heat can be safely applied to the boiler.*

1. Area check – verify suitability for operation
2. Caster wheels must be in the locked position
3. Keyed master switch is in the off position
4. Burner switch is in the off position
5. Load switch is in the off position
6. Load rheostat is in the minimum load, full counter-clockwise position
7. Operator panel gas valve is in the off position
8. The condenser tower should be drained
9. The front and rear boiler doors must be closed and latched
10. The steam admission valve must be open
11. The boiler should be drained completely

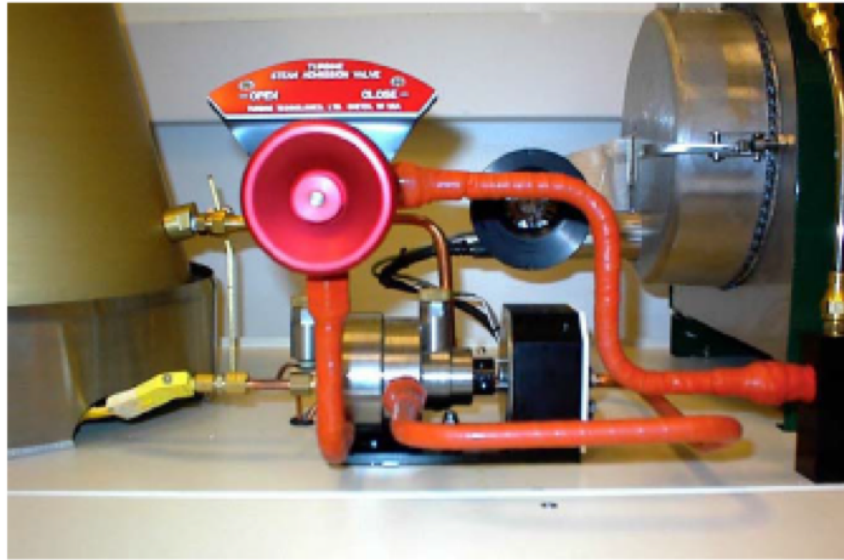

Figure 2: Close up of steam valve (the red wheel), turbine (in steel casing), and generator (black). In the background is the boiler with its blower (right) and the condensation 'tower' (left).



Figure 3: The boiler (open). The flame burns in the large pipe and the hot combustion gas returns through the smaller pipes to the exhaust chimney. The burner is mounted on the door. The lower part of the boiler contains liquid, the upper part contains steam. The upper pipes are surrounded by steam, which can be superheated.

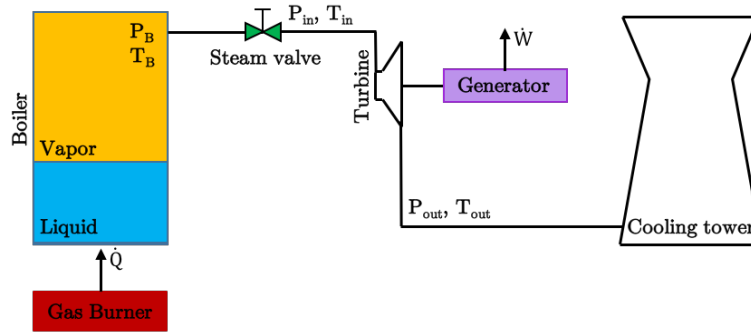

Figure 4: Simple schematic for the Rankine Cycle. The indicated pressures and temperatures are recorded during the experiment; the generator power can be computed from the measured current  $I$  and voltage  $V$  as  $P = I \times V$ . Additionally, the volume flow of the propane gas is also measured.

12. **Fill the boiler with 203 oz (6,000 ml) of clean, distilled water**
13. The fill equipment should be stowed
14. **Turn the steam admission valve to the closed position**
15. The computer DAQ system USB cable should now be connected
16. The rankine cycle electrical service should be connected
17. The fuel source line should be connected

## 4.2 Starting & Preheating the System

1. Turn Gas valve to ON, on the propane gas canister.
2. Turn Gas valve to ON, on the Rankine Cycle.
3. Listen and smell for propane gas leak. If none then proceed to next step.
4. Keyed Master Switch to ON
5. **Click on PdaqView .exe** icon on your computer's desktop screen. This takes you to the data display and recording screen.
6. **Click on the menu bar** for updating all meters and channel configuration chart and verify all the meters are reading properly.
7. **Click on the menu arm trigger to start recording the data to a file.** At the end of data run click on this menu button to stop data logging.
8. Burner switch to ON
9. LOAD rheostat fully counterclockwise, LOAD is OFF
10. Wait 45 seconds till you hear the flames (Burner is lit)
11. Watch the Pressure dial it will reach 110 psig after about 5 minutes.
12. Turn Steam Admission Valve to OPEN slowly till pressure = 40 psig.
13. Turn Steam Admission Valve to CLOSE and wait for pressure to reach 110 psig.
14. Turn Steam Admission Valve to OPEN slowly till pressure = 40 psig.
15. Turn Steam Admission Valve to CLOSE and wait for pressure to reach 110 psig.

The system has been pre-heated; **you are now ready to run the experiment.**

### 4.3 Running the Test

1. Very slowly open the Steam Admission Valve – the generator should be spinning and voltage out (on the voltmeter located on the operator panel) should be close to 15 volts (**Never exceed 15 V**).
2. Turn on LOAD switch and set load to about 200 mA at 6 volts while maintaining a steam pressure of about 110 psig with manipulation of the Steam Admission Valve.
3. **The STEAM ADMISSION VALVE and the LOAD RHEOSTAT must be adjusted to achieve a STEADY STATE CONDITION. Satisfactory run-time results can be achieved with the following STEADY STATE values:**

- An AMP METER indication of approximately 0.2 Amps.
- A VOLT METER indication of approximately 6.0 Volts.
- A BOILER PRESSURE indication of approximately 110 psi (758 kPa).

(Note that these values need not be matched exactly. *When a reasonable STEADY STATE is ACHIEVED, your experiment has started*).

4. **To begin an experimental run, the scan number must be NOTED in your logbook from the display in the data acquisition program.** This allows a steam rate calculation to be made at the conclusion of the experimental run.
5. For this scan number, also **note the water level in the boiler** through the sight glass. This allows measurement of the boiler water consumed during the experimental run.
6. Use the STEAM ADMISSION VALVE to make PERIODIC ADJUSTMENTS maintaining the STEADY STATE as described in Step 3.
7. Allow the system to run in the steady state for 5-10 mins. At this point monitor the water level in the sight glass and it **should not be allowed to drop less than 2.5 cm** from the bottom of the sight glass.
8. At the end of the steady state test, again **note the scan rate and the water level in the boiler**.

After the steady state run is complete **SAVE THE DATA by clicking on the arm trigger button again.**

### 4.4 Shutdown

1. Select the BURNER SWITCH to OFF.
2. Turn STEAM ADMISSION VALVE to the CLOSED position.
3. The OPERATOR PANEL GAS VALVE should be selected OFF.
4. The LOAD RHEOSTAT should be turned FULL COUNTER-CLOCKWISE.
5. The LOAD SWITCH should be selected OFF.
6. MAKE SURE THAT YOU HAVE SAVED YOUR DATA. IF SO, GO TO STEP 7
7. The MASTER SWITCH should be selected OFF.
8. The STEAM ADMISSION VALVE should be now turned SLOWLY AND PARTIALLY. This relieves all remaining boiler pressure.
9. The FUEL SOURCE valve should now be turned OFF.

#### 4.5 Other Measurements

1. Place the measuring jar underneath the condenser tower. Drain the condensate collected in the tower into the jar by squeezing the hose pinch. Measure the condensate collected.
2. Once the boiler pressure reaches atmospheric conditions, fill the measuring beaker with distilled water and re-fill the boiler through its drain/fill port to the exact level noted down at the start of steady state run. The amount of water used for this purpose represents the boilers total steam production. Hence, the steam rate can be obtained by dividing the weight of the water collected by the total time for the steady state run.