

Instructions for Take-home Test Questions

Read the instructions below, and after completing your questions, submit this sheet, signed in the spaces below.

1. Do not share your solutions or answers with anyone.
2. You can work on any computer in the college, or on your own home computer.
3. If you have any questions, find me, call me at 410-6223, or email me at namilae@eng.fsu.edu.
4. Use ALGOR for the analyses. Use appropriate font sizes to make load vector, boundary conditions, and their magnitude are visible on the screen. Take printout of *.esd files and stress, displacement files and include in your solution script. Include all the design calculations.

Note that if there is any blatant copying, all involved parties will receive a score of 0 for the complete take-home. Penalties for copying will most likely result in a failing grade. If you have any questions, contact me first.

Problem solutions are due by 5.00 PM. Friday, December 10, 2004 in my office B 350.

I certify that the work submitted by me is solely my own. I have not copied anyone else's work. I have not given help to or solicited help from anyone on any of these solutions.

(Signature)

(SSN)

- Members of the plane structure may be bars pinned at the joints to create a truss to lift boxcars as shown in figure 1. Investigate the truss using Algor. Design all the members of truss assuming the permissible tensile stress of 120 MPa and that of compression as 90 MPa. Also check for compression members for buckling strength (use appropriate Euler's formula). List largest nodal displacements and their locations. Material is steel ($E=200\text{GPa}$) and cross sectional area of all the members is 10cm^2

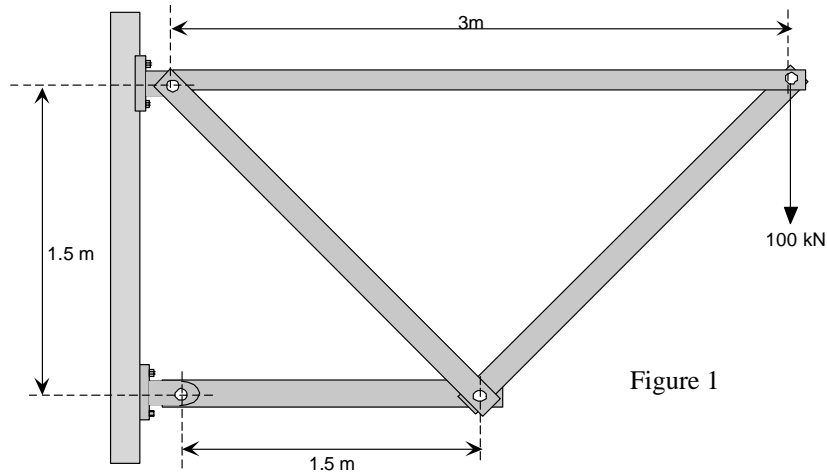

- A reinforced concrete slab floor is shown in the figure 2. Using unit width of the slab in the z direction, find the deflections in the slab under its own weight. (EI for concrete= 4.5×10^6 psi, Weight per cubic feet is 145 lb)

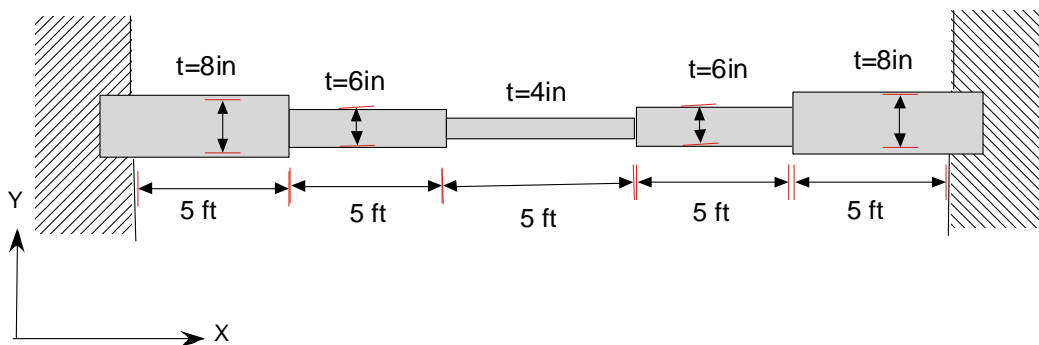

- A machine part supports an end load of 1000 lb. As shown in figure 3. Assuming constant thickness of 1.0 in find the thickness 't', such that maximum tensile and compression stresses are limited to 20 ksi. Check for yielding (Yield stress = 36ksi). Assume standard mild steel is used for the part. Include plot of the deflected shape of model and a stress plots for normal stresses in x and y direction, shear stress plot and von Mises stress plot and a plot showing the boundary conditions.

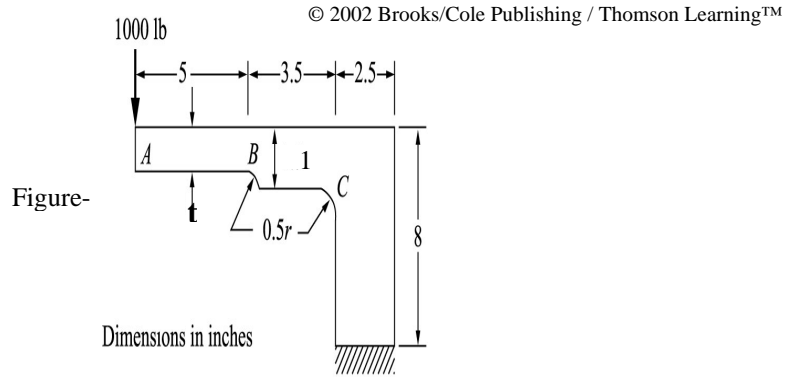

4. An S shaped block is used in force measurement as shown in figure 4, and is subjected to a uniform pressure of 1200 psi applied uniformly on top surface. Determine the uniform thickness of the block needed such that the sensor is compressed no more than 0.05 inches. Also make sure that maximum von Mises stress is less than yield strength of the material. Use a factor of safety of 1.5 on the stress only. The overall size of the block must fit in a 3.0 -in.-high, 1-in.-wide, 2-in.-deep volume. The block is made of steel. Submit all Algor plots indicating the maximum stresses, maximum deflections, and boundary conditions applied.

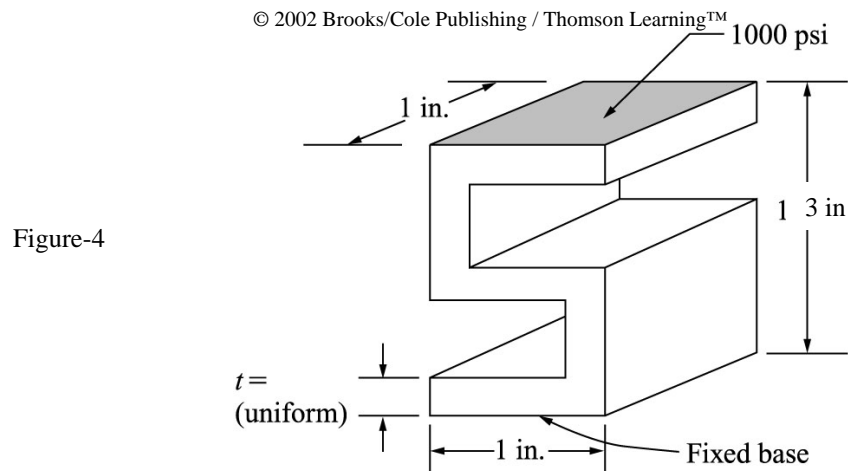

5. For the thick walled open ended cylindrical pipe subjected to internal pressure of 5000 psi (figure 5). Using the axisymmetric elements obtain the circumferential stress σ_{θ} and the principal stresses and maximum radial displacement. Compare the result with exact solution (see thick walled shell in Mechanics of Solids) $E= 30 \times 10^6$ psi and $\nu = 0.3$

figure 5

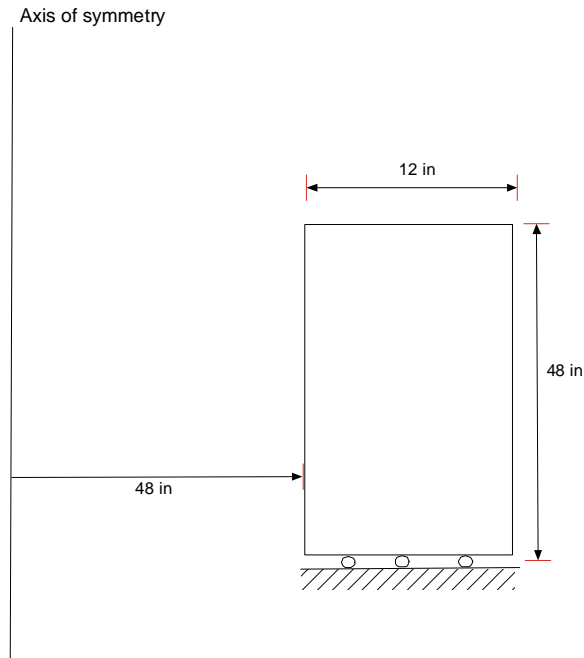

6. A Square duct shown below carries hot gases such that its surface temperature is 570 F. The duct is insulated by a layer of fiberglass that has thermal conductivity of $K = 0.02$ Btu/(h-ft-F). The outside temperature of fiberglass is maintained at 110F. Determine the temperature distribution within the fiberglass.

Figure 6

