

Earth Retaining Walls



Design of Retaining Wall

Types of Earth Retaining Walls

I- Permanent Walls

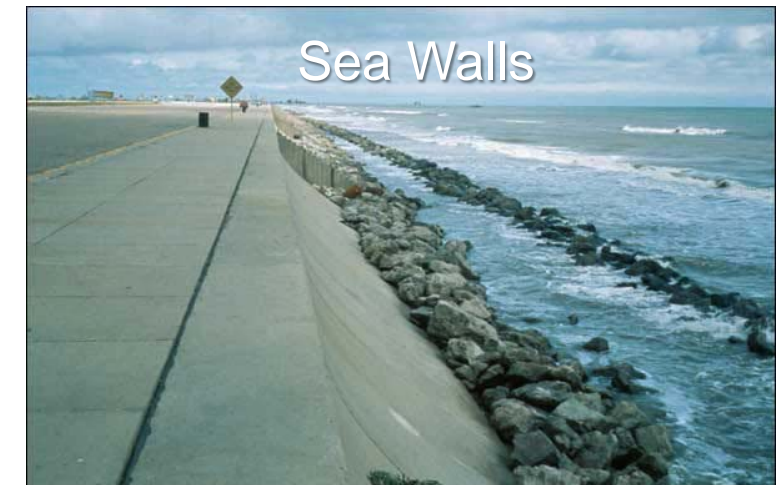
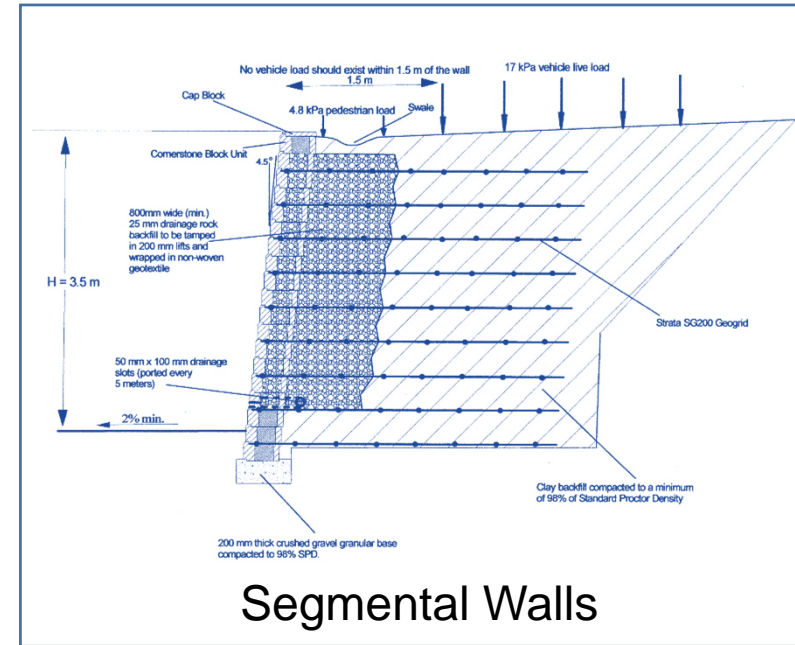
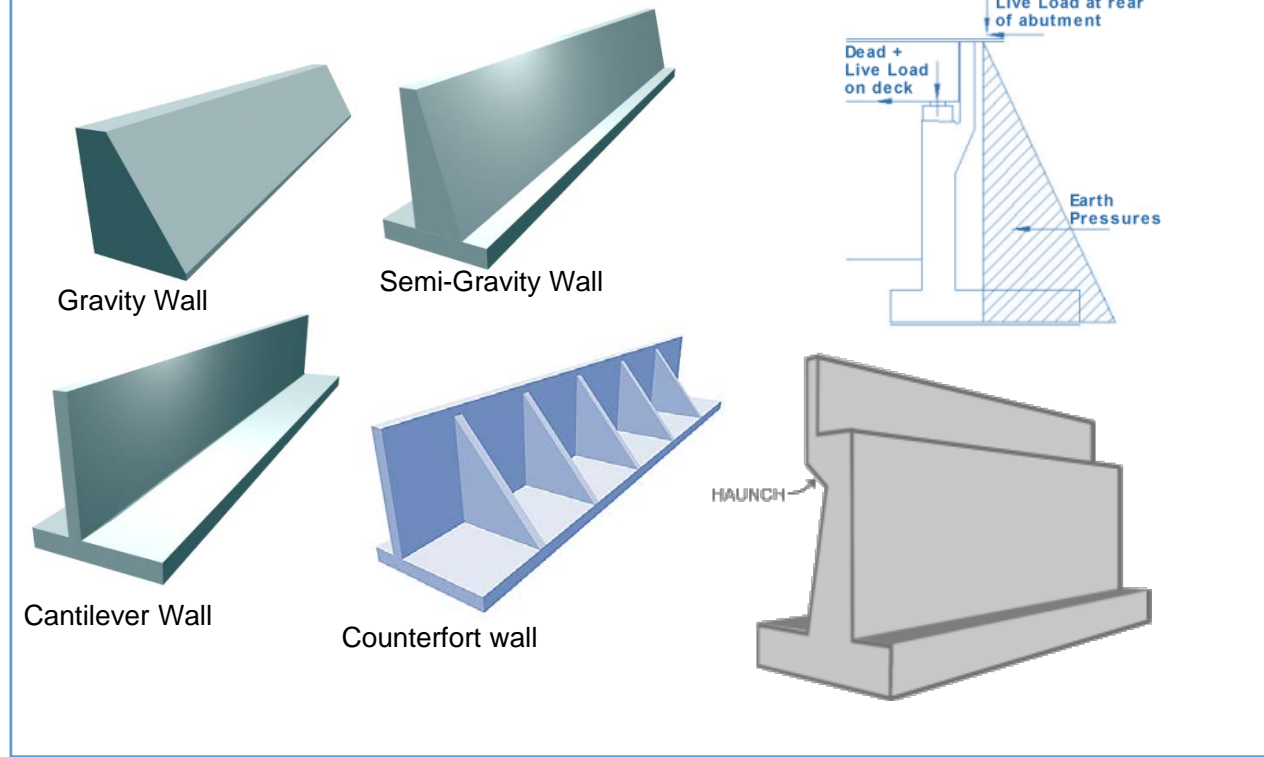

II- Temporary Walls

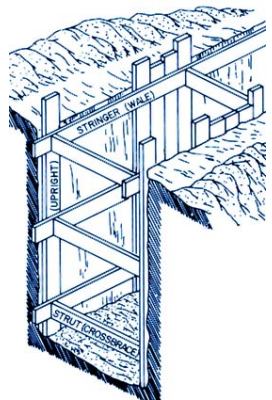

Sheet pile wall



Design of Retaining Wall

- 1- External Stability
- 2- Internal Stability

1. External Stability

- 1- Sliding
- 2- Overturning
- 3- Settlement
- 4- Overall Failure

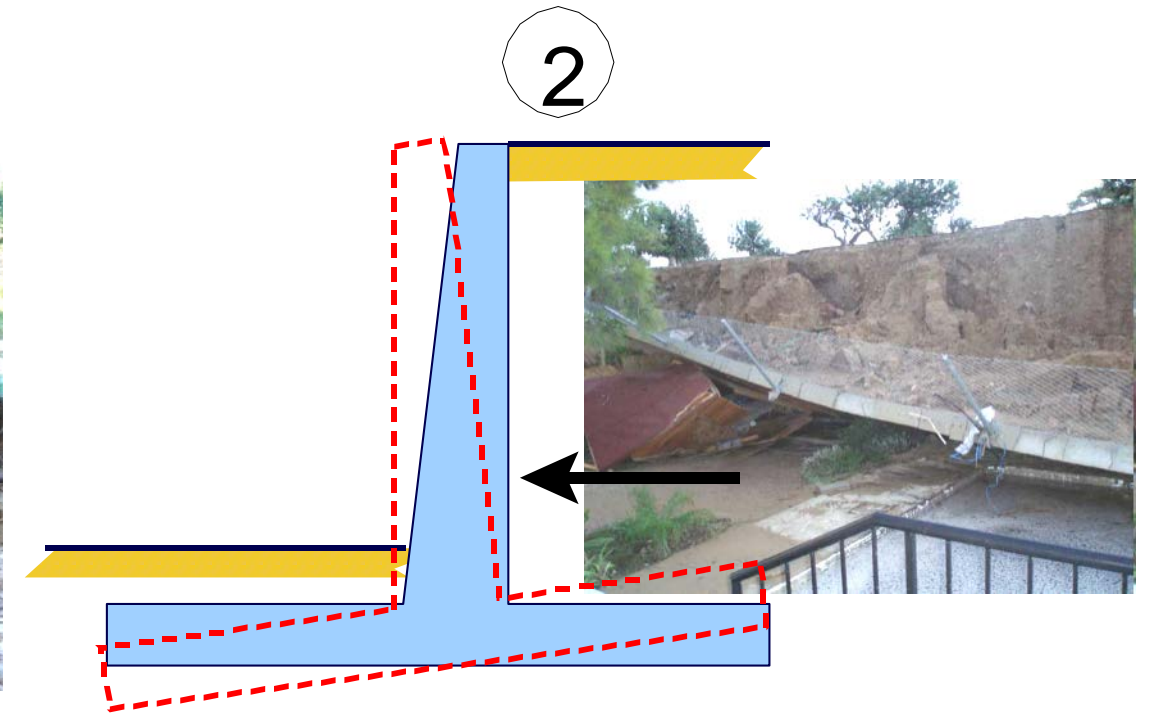
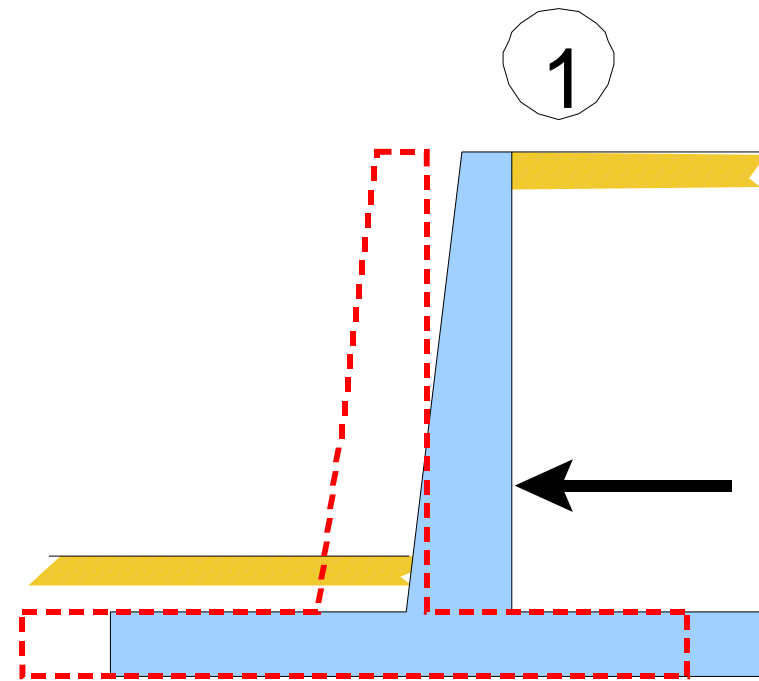
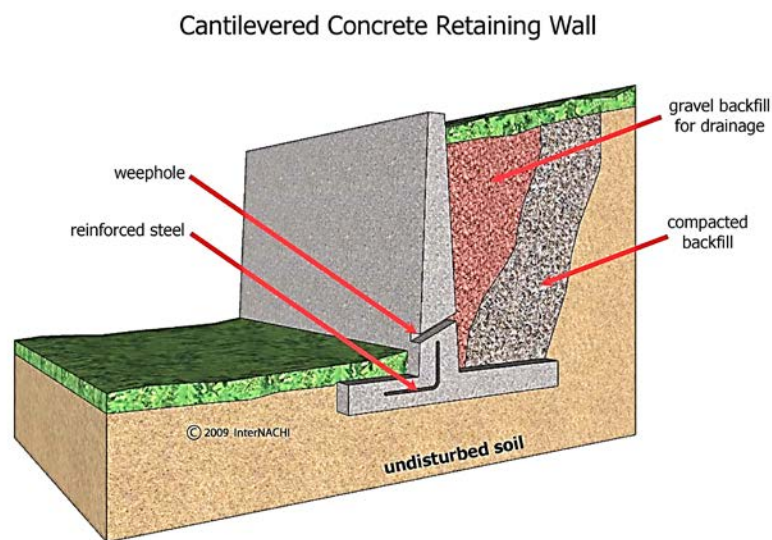

3

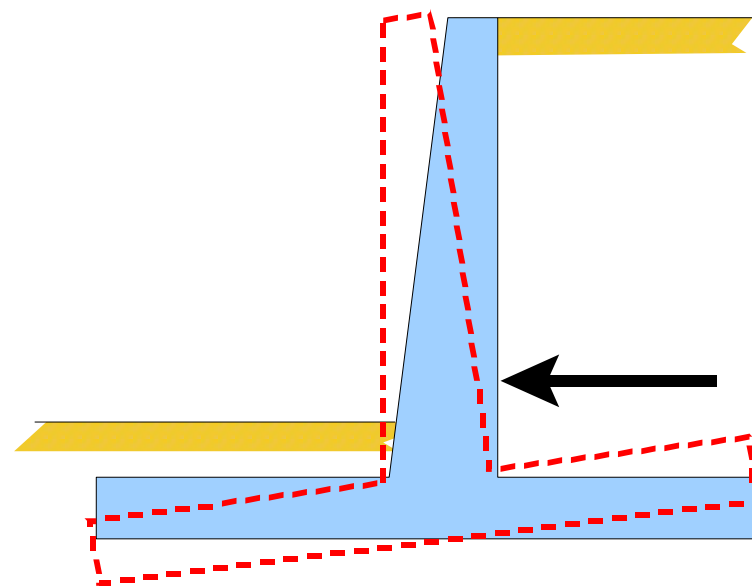

4

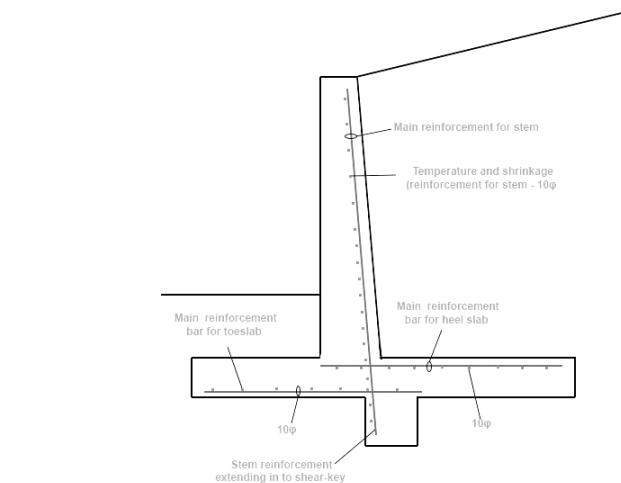
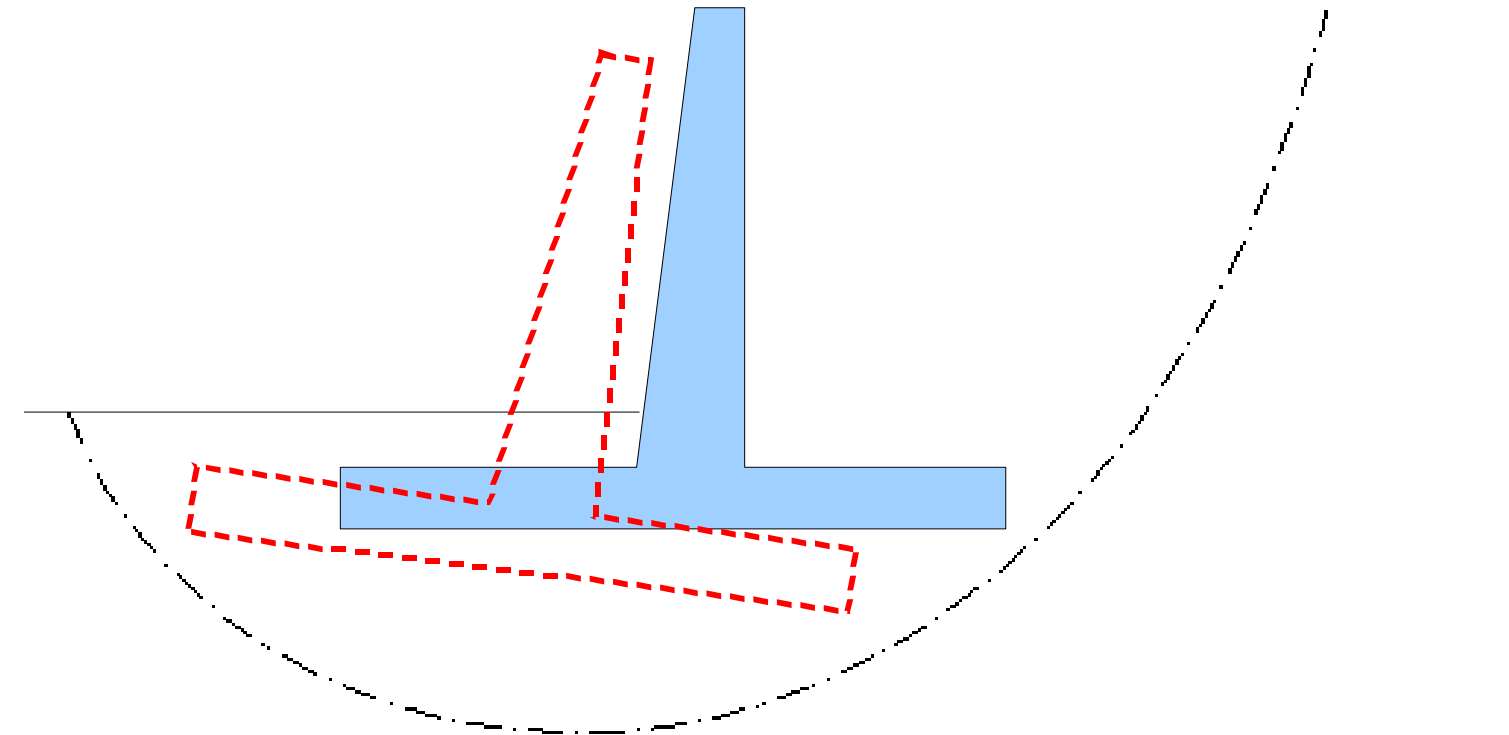

Internal Stability
Steel Reinforcement and Thicknesses

Common Proportions of Cantilever Wall

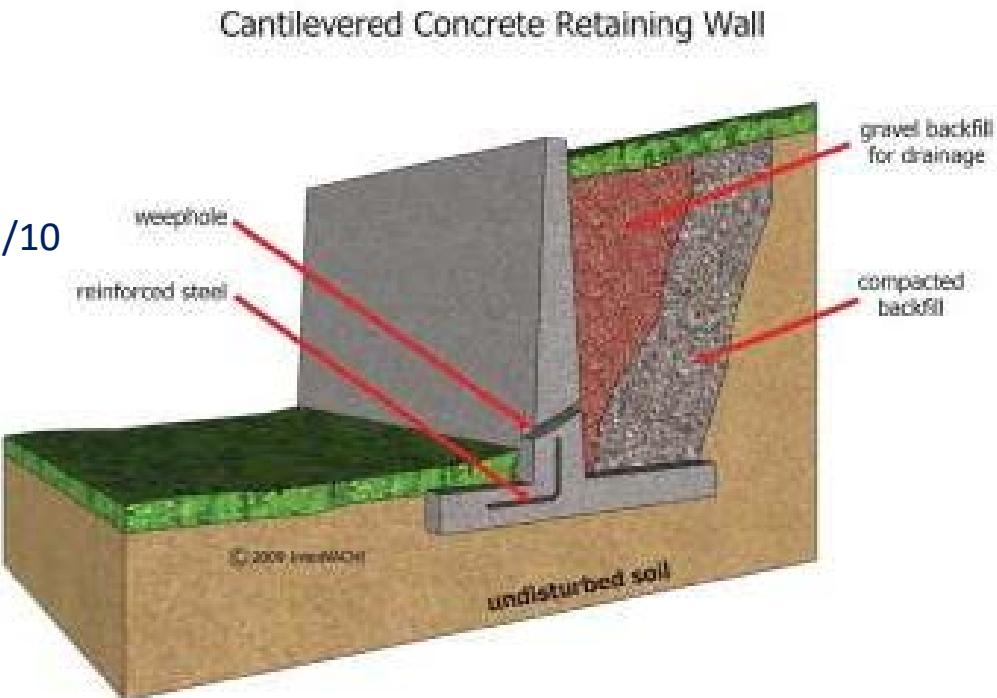
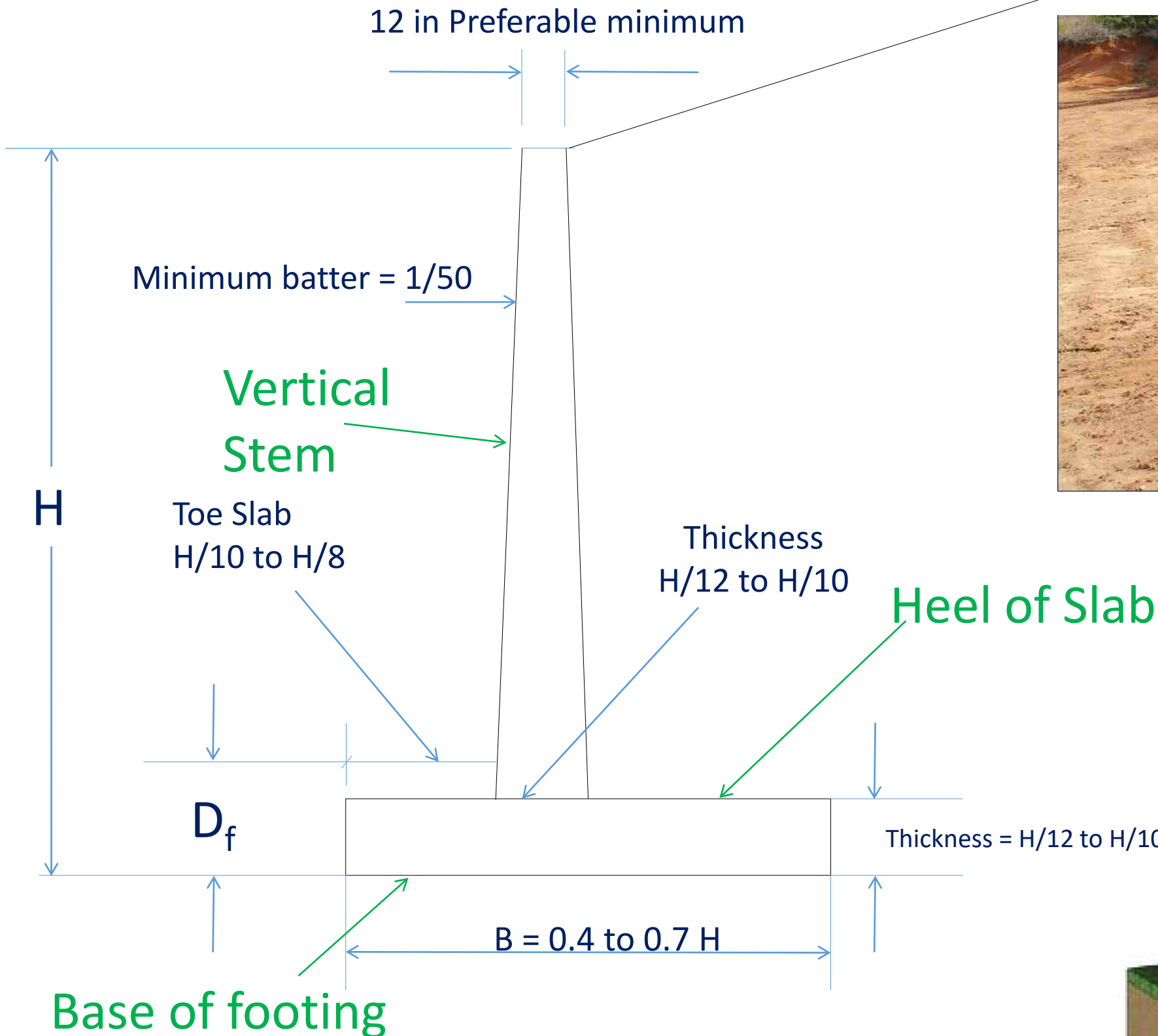

Approximate Dimensions

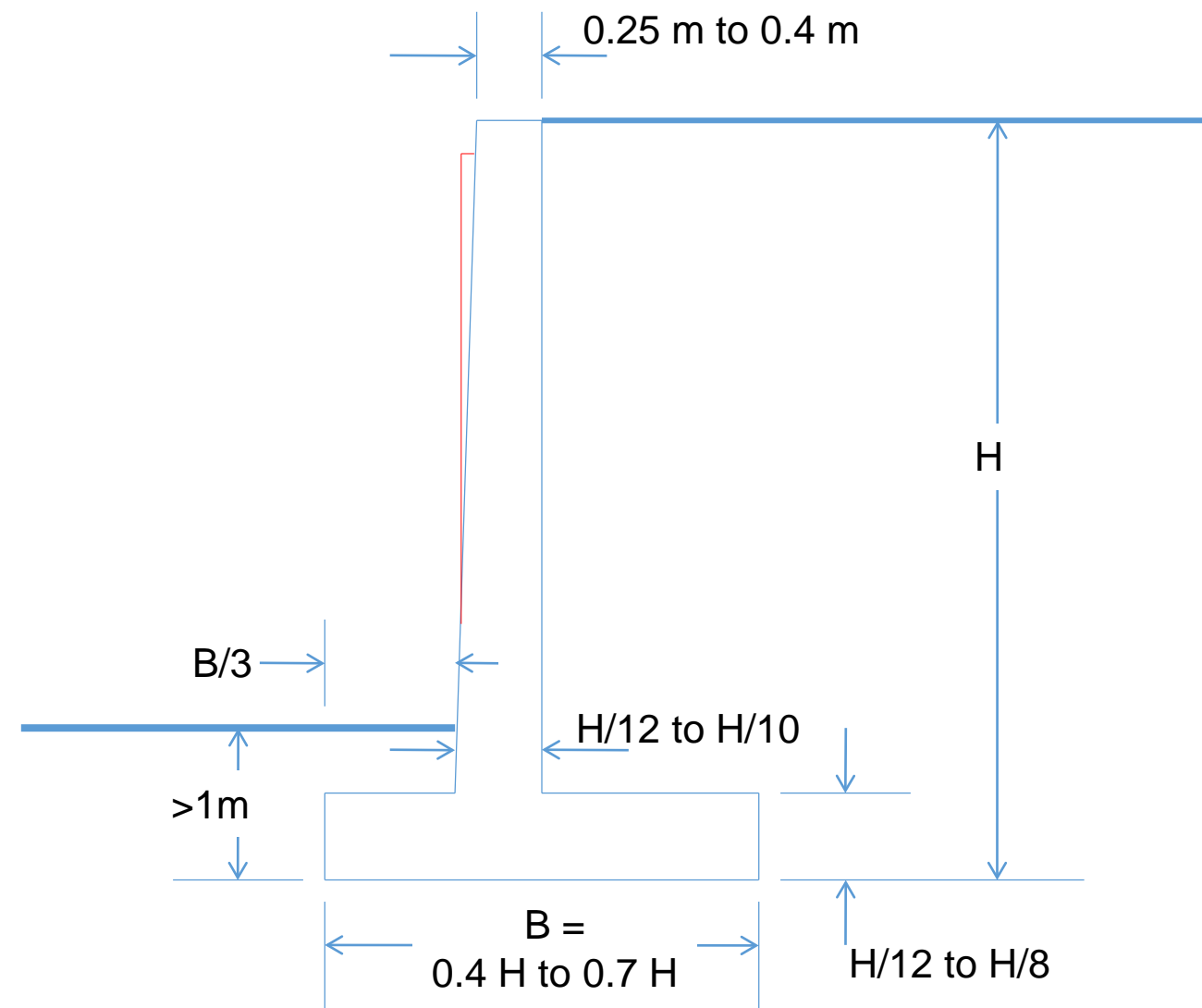

Cantilever Retaining Wall

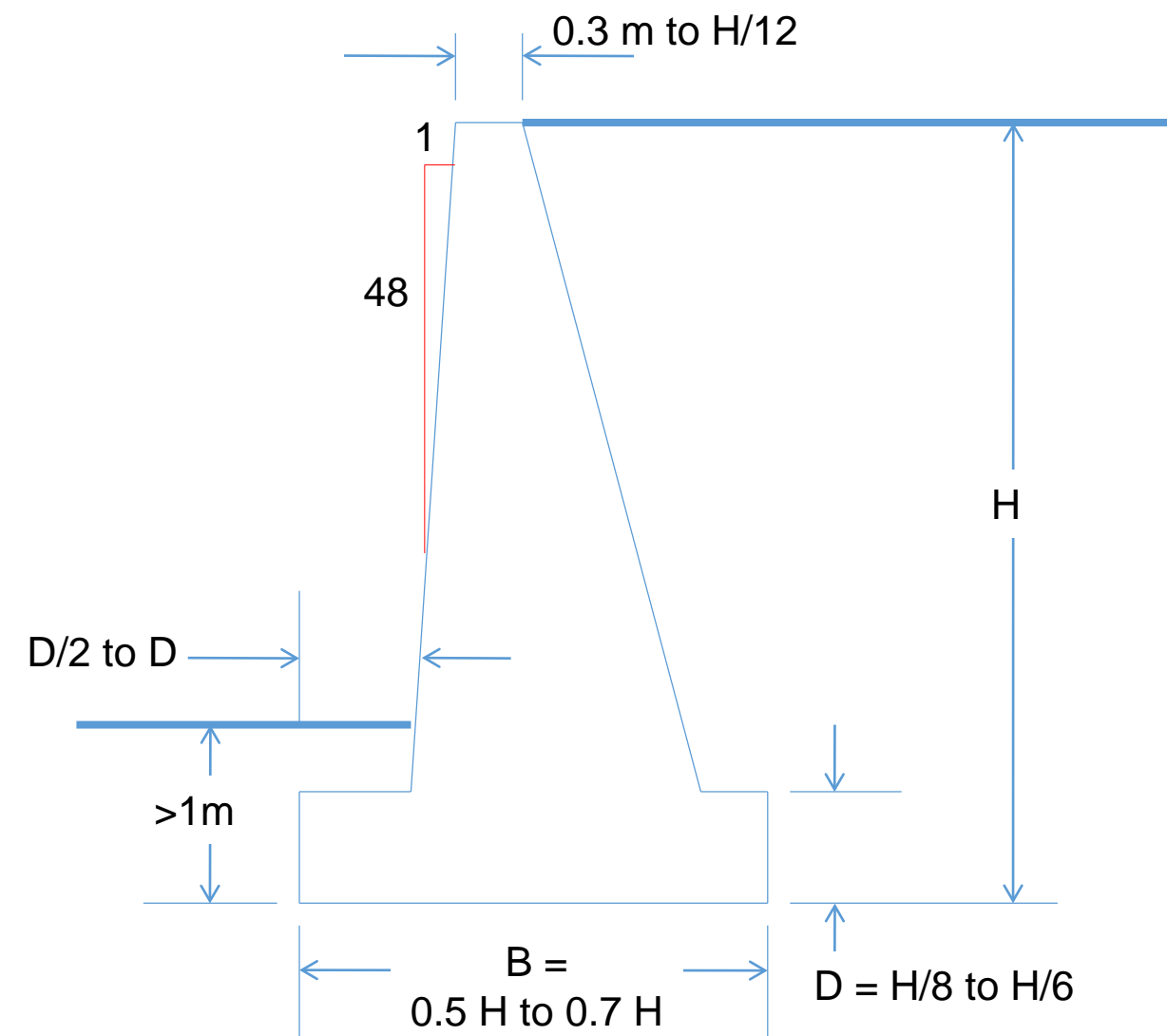

Gravity Retaining Wall

Counterfort Retaining Wall

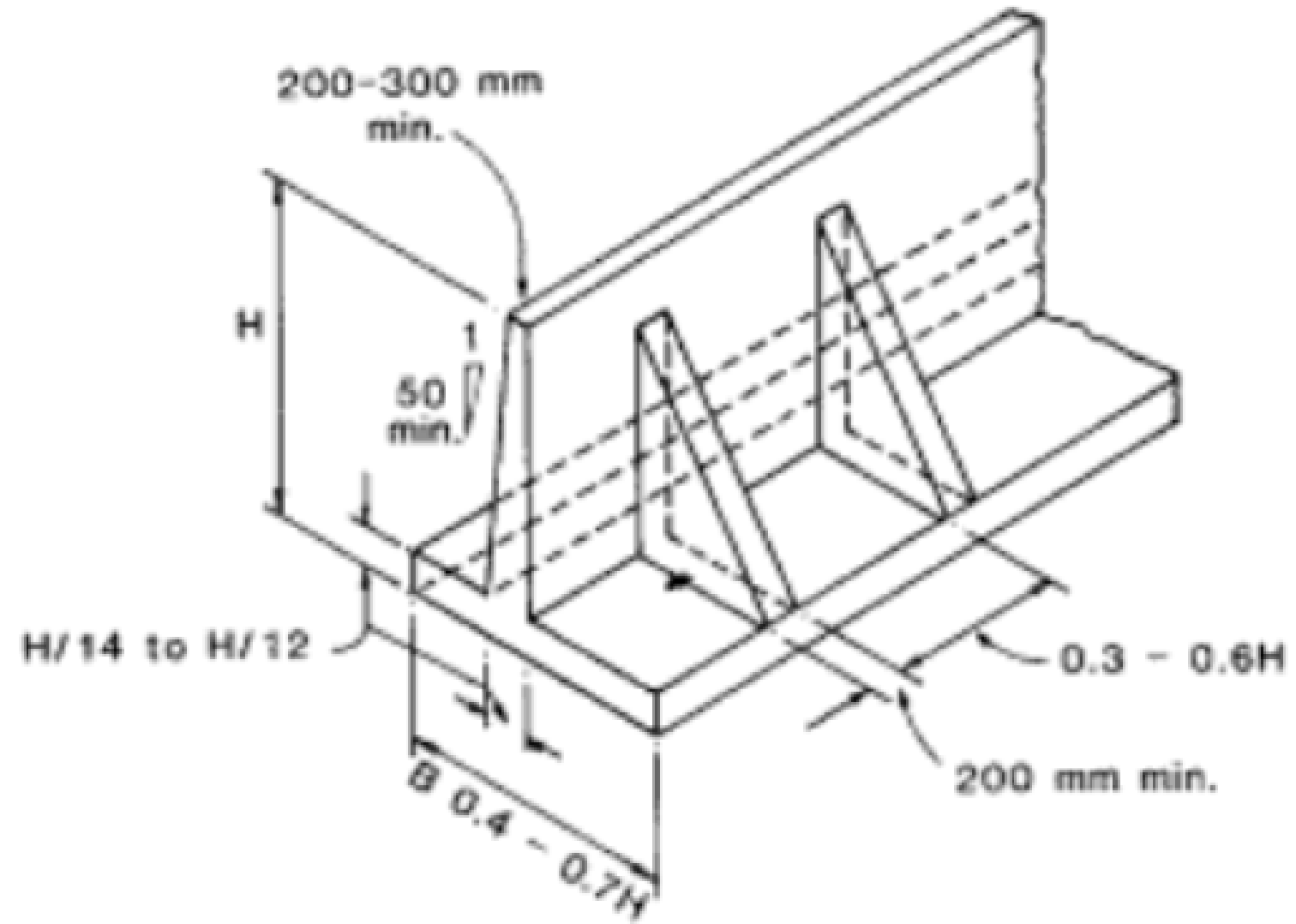

Internal Stability

Structural Design

Steel Reinforcement
and Thicknesses

Structural Design

2-

Internal Stability

Section I-I

The earth pressure on the stem will cause moment at section I-I

$$\text{Moment}_{I-I} = P_a \cdot \text{arm}$$

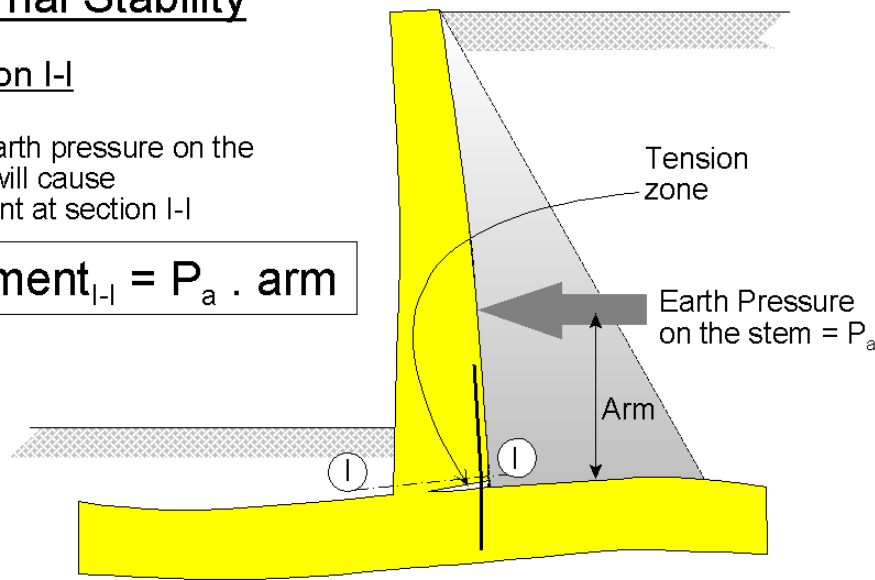

Internal Stability

Section II-II

The bearing pressure on the footing will cause moment at section II-II

$$\text{Moment}_{II-II} = \text{Force} \cdot \text{arm}$$

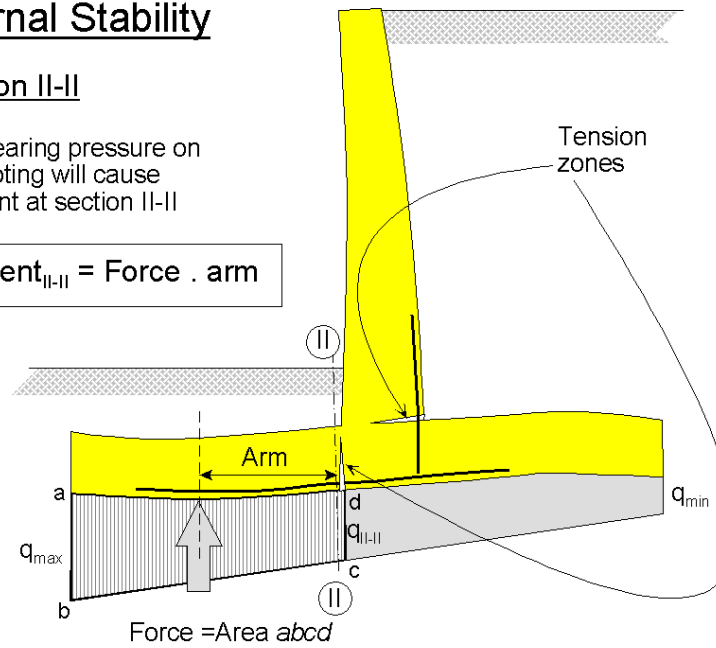

Internal Stability

Section III-III

The bearing pressure on the stem will cause moment at section III-III

$$\text{Moment}_{III-III} = \text{Net Force} \cdot \text{arm}$$

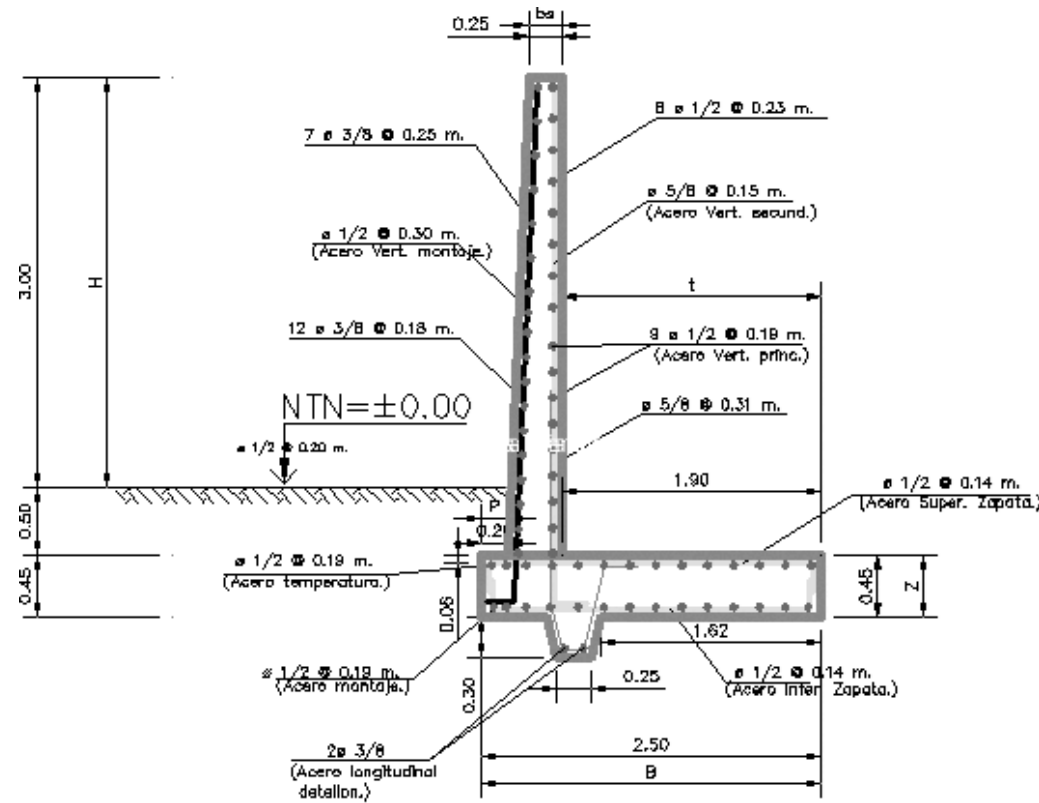
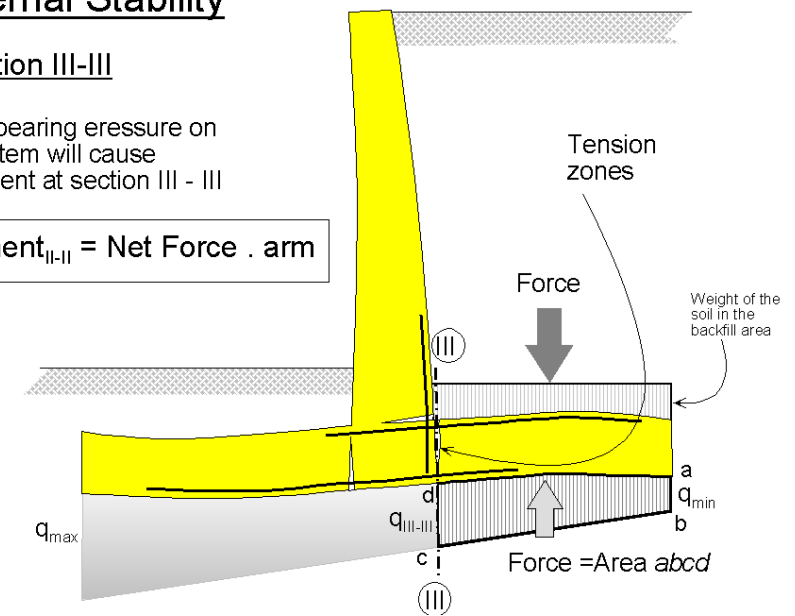

DETALLES DE MURO DE CONTENCIÓN

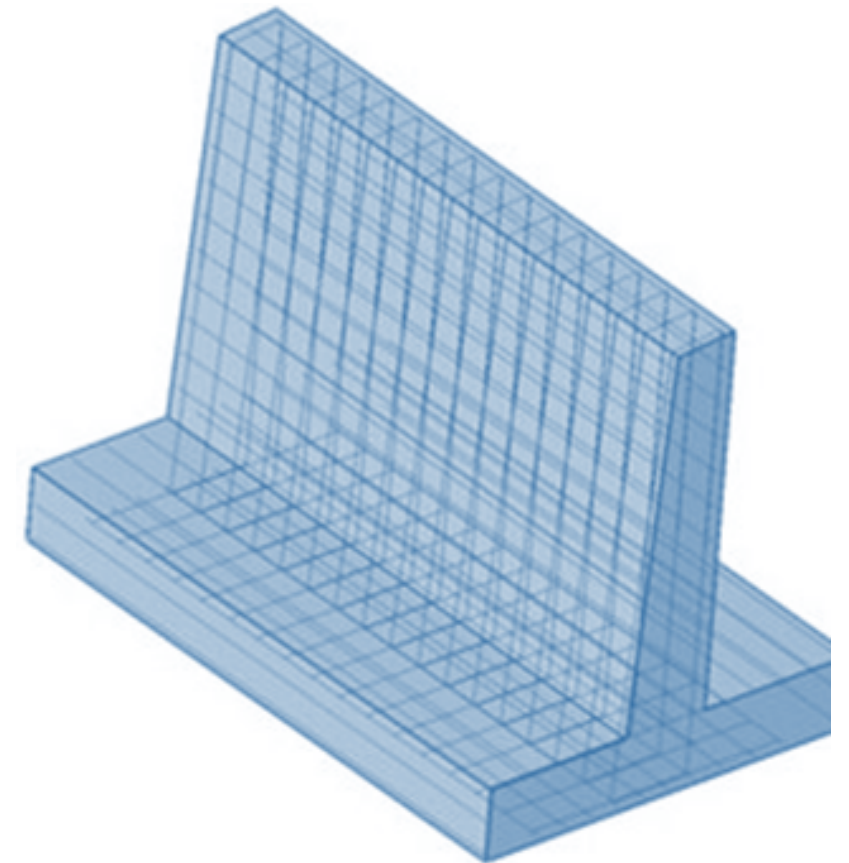

I. External Stability

1- Sliding

$$\text{Factor of Safety Against Sliding} = \frac{\text{Resisting Force}}{\text{Driving Force}} = \frac{F_R}{F_D}$$

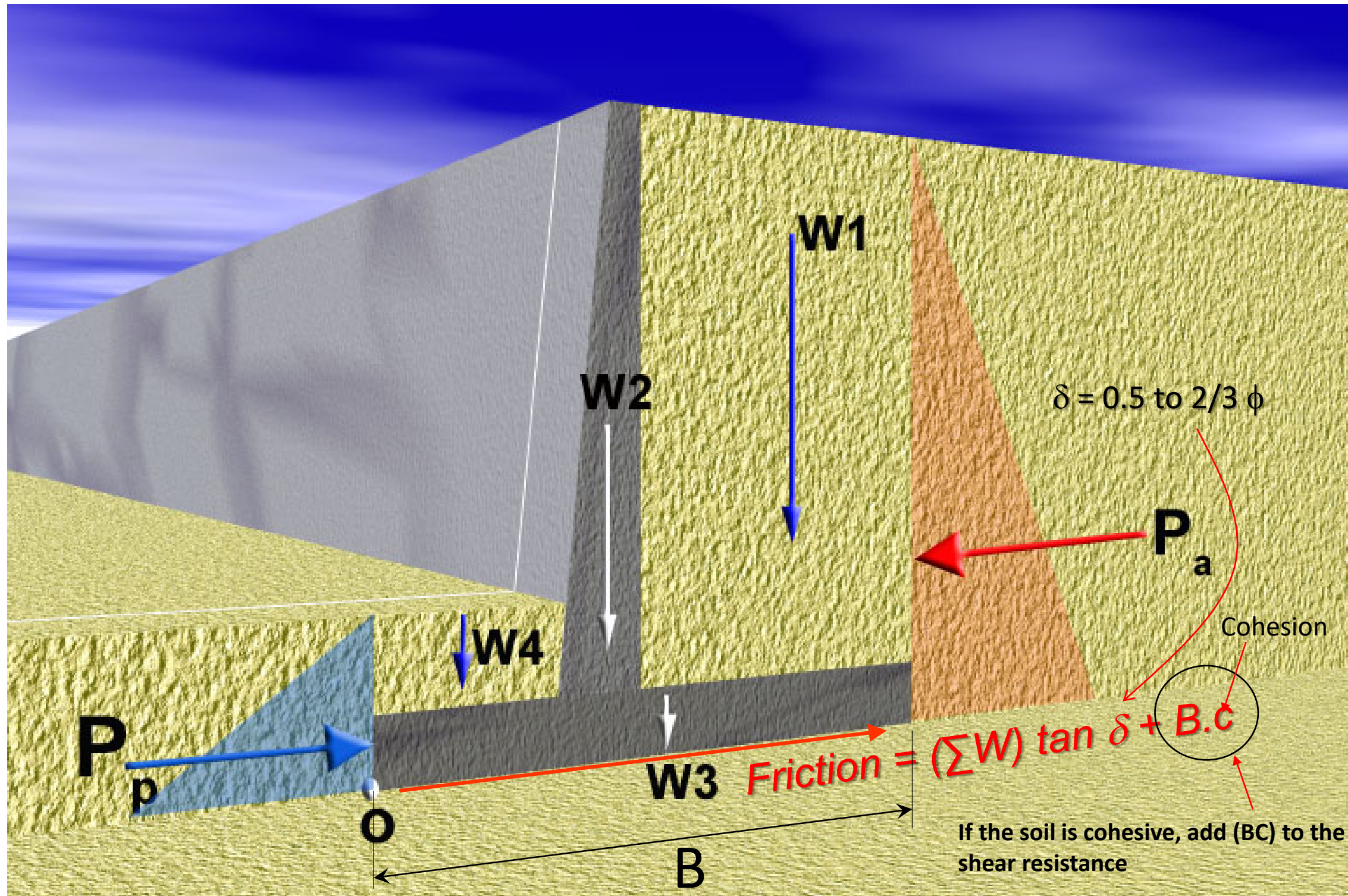

$$F_D = P_a$$

$$F_R = P_p + \text{Friction}$$

I. External Stability

2- Overturning

$$\text{Factor of Safety Against Sliding} = \frac{\text{Resisting Moment}}{\text{Driving Moment}} = \frac{M_R}{M_D}$$

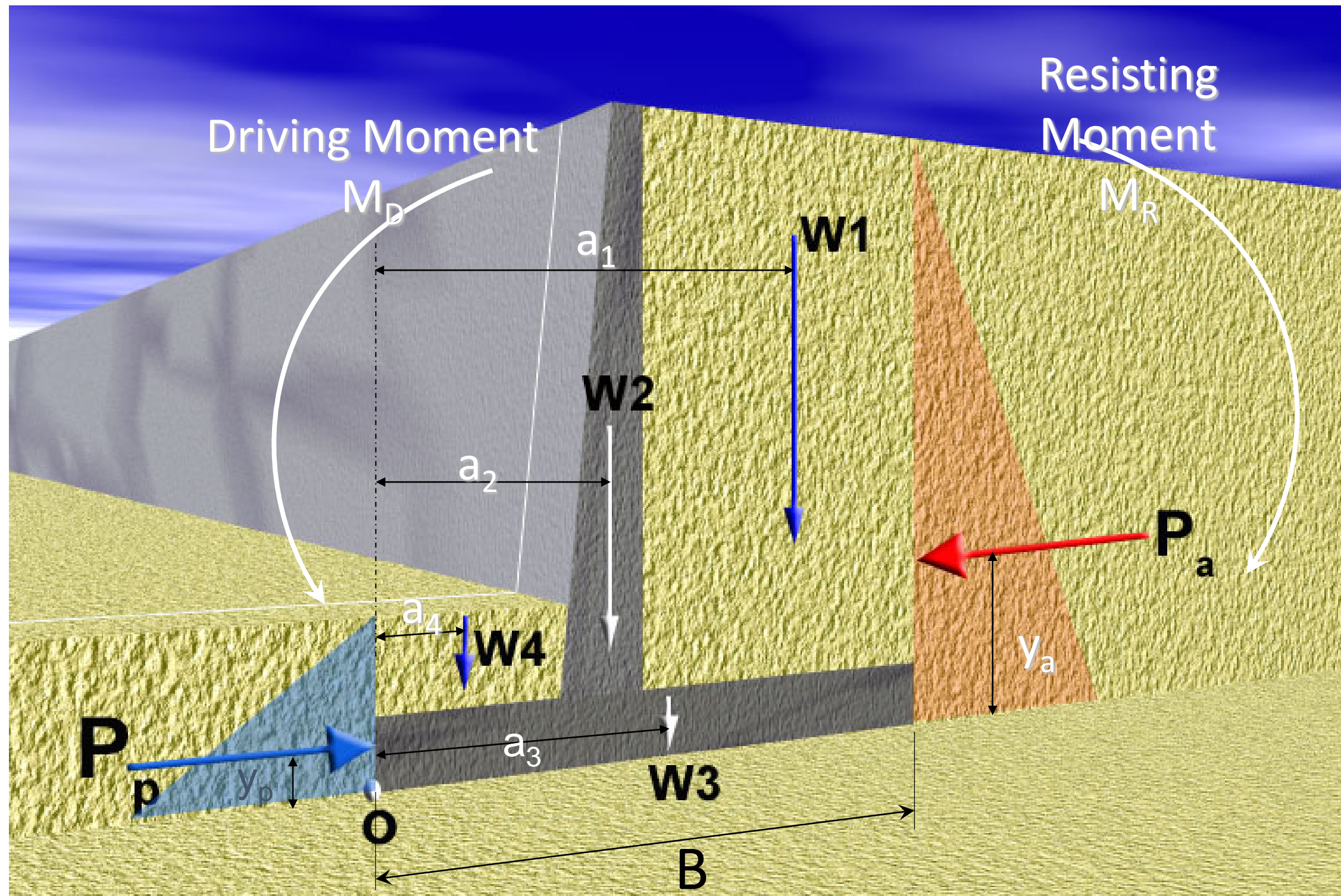

Moment About o

$$M_D = P_a \cdot y_a$$

$$M_R = P_p \cdot y_p + W_1 a_1 + W_2 a_2 + W_3 a_3 + W_4 a_4$$

I. External Stability

3- Bearing Capacity Failure

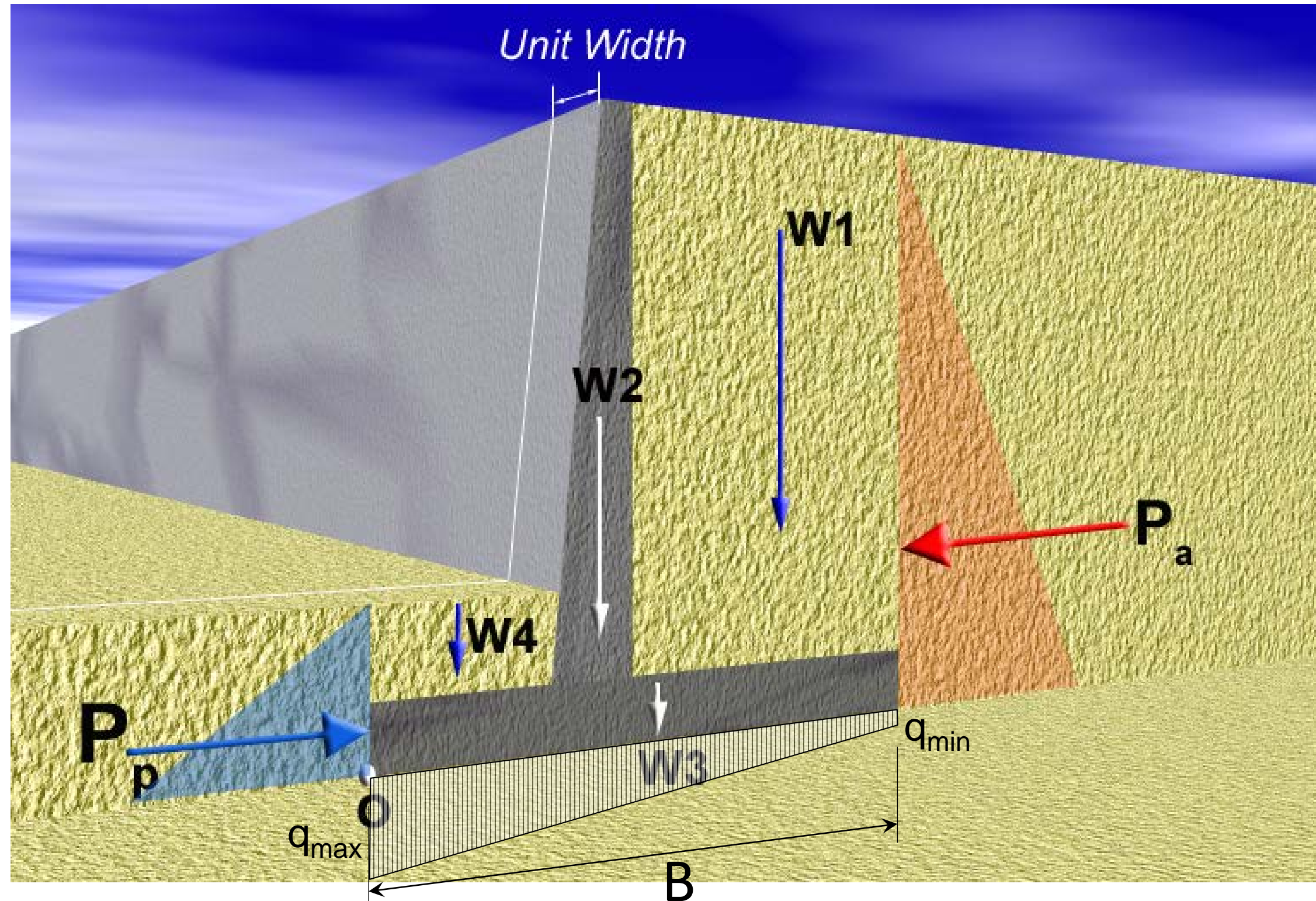

3- Check for Bearing Capacity Failure

Factor of Safety Against Bearing Capacity Failure = $\frac{q_{all}}{q_{max}}$

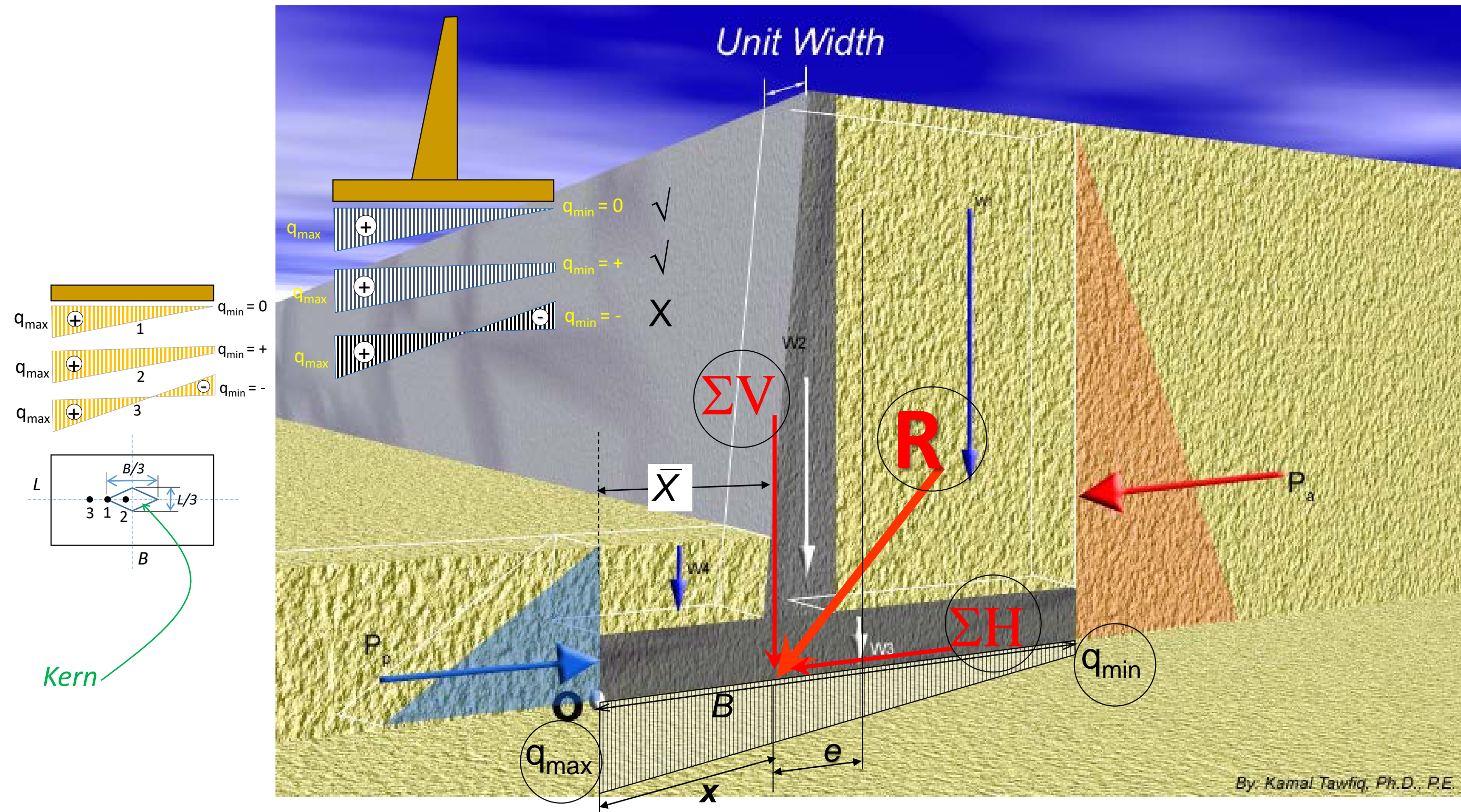

By: Kamal Tawfiq, Ph.D., P.E.

ΣV = sum of all vertical loads
 ΣH = sum of all horizontal loads
 $R = \sqrt{(\Sigma V)^2 + (\Sigma H)^2}$

$M_{net} = \Sigma M_R - \Sigma M_D$
 $\Sigma V \bar{X} = M_{net}$

$e = \frac{B}{2} - \bar{X}$
 $q = \frac{\Sigma V}{A} \pm \frac{M_{net} y}{I}$

$q_{\frac{max}{min}} = \frac{\Sigma V}{B} \left(1 \pm \frac{6e}{B} \right)$

Retaining wall with a key at the base:

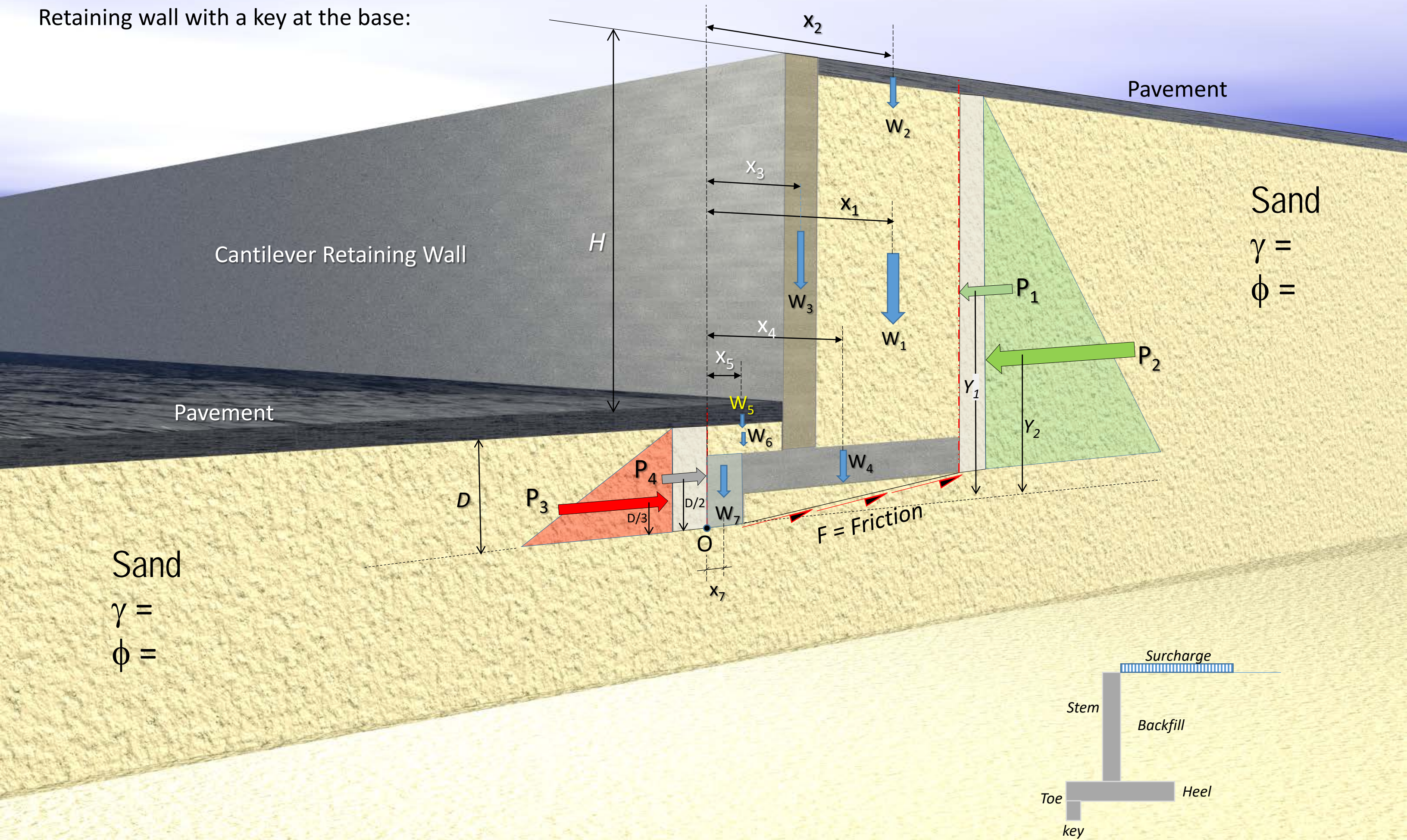

Using Key at the Base to Improve Sliding Resistance

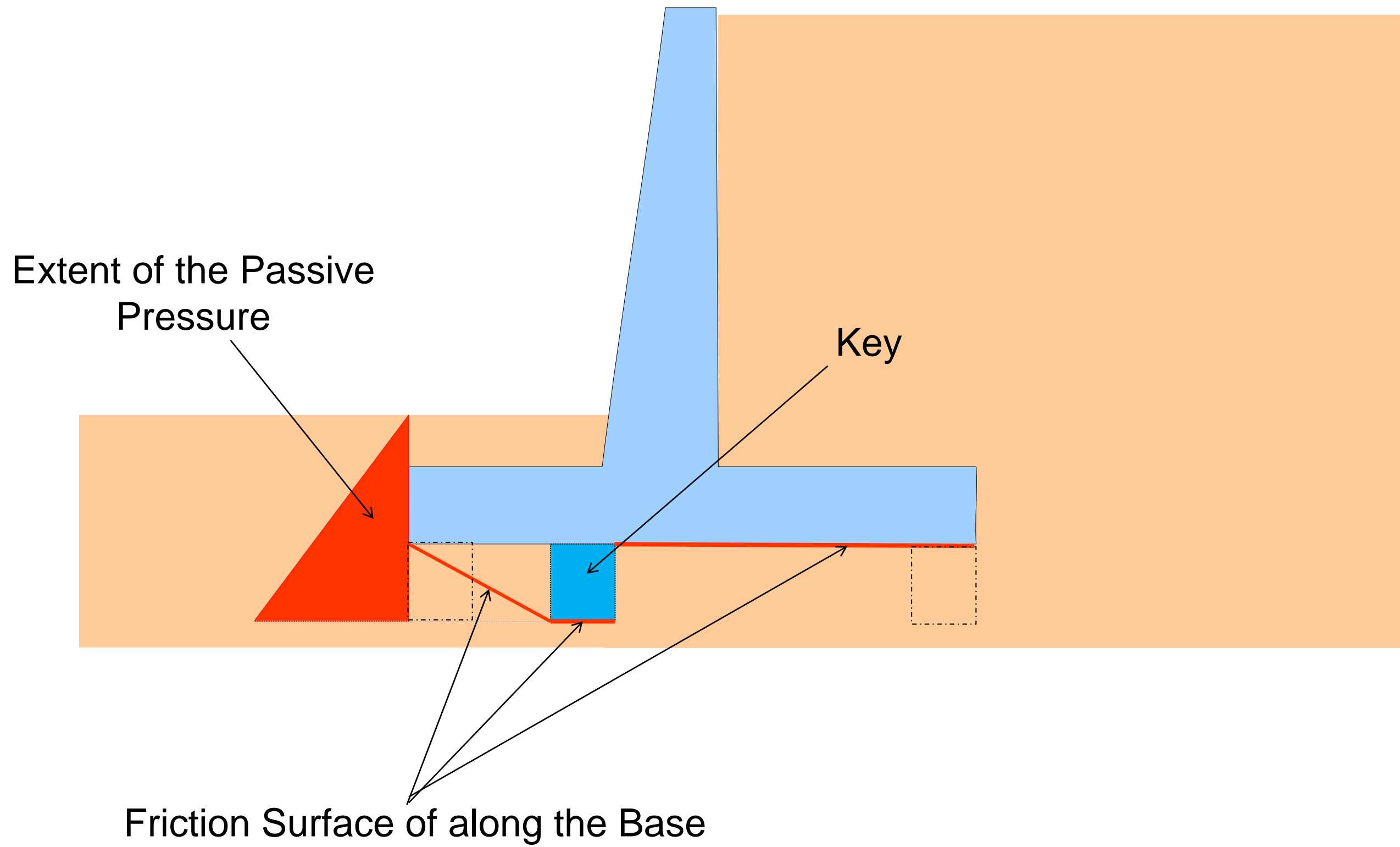

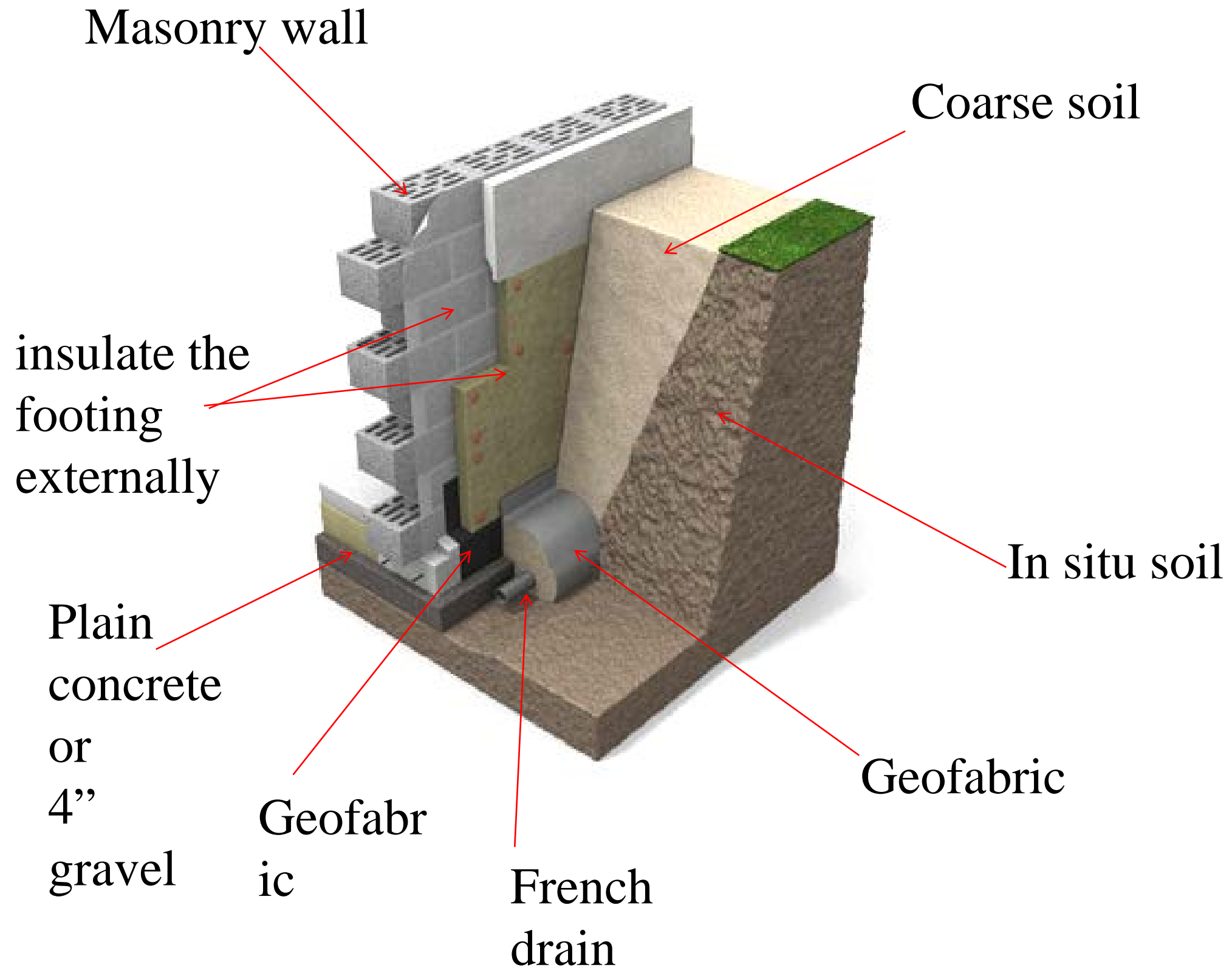

Active Earth Pressure in ϕ – Soil

Example -1

Given:

- Vertical retaining wall (Rigid)
- Wall height (H) = 12 ft
- Backfill unit weight (γ) = 115 pcf
- Angle of soil friction (ϕ) = 30°
- Assume wall to be smooth
- Angle of friction between the base and the soil $\delta = 20^\circ$

Determine:

The stability of the wall

Solution:

$$\sigma_h = \sigma_v k_o \quad \text{For Rigid Wall use } k_o$$

$$P_o = 0.5 \gamma H^2 k_o$$

$$K_o = 1 - \sin\phi$$

$$P_o = 0.5 \times 115 \times 12^2 \times 0.5 = 4,140 \text{ lb/ft}$$

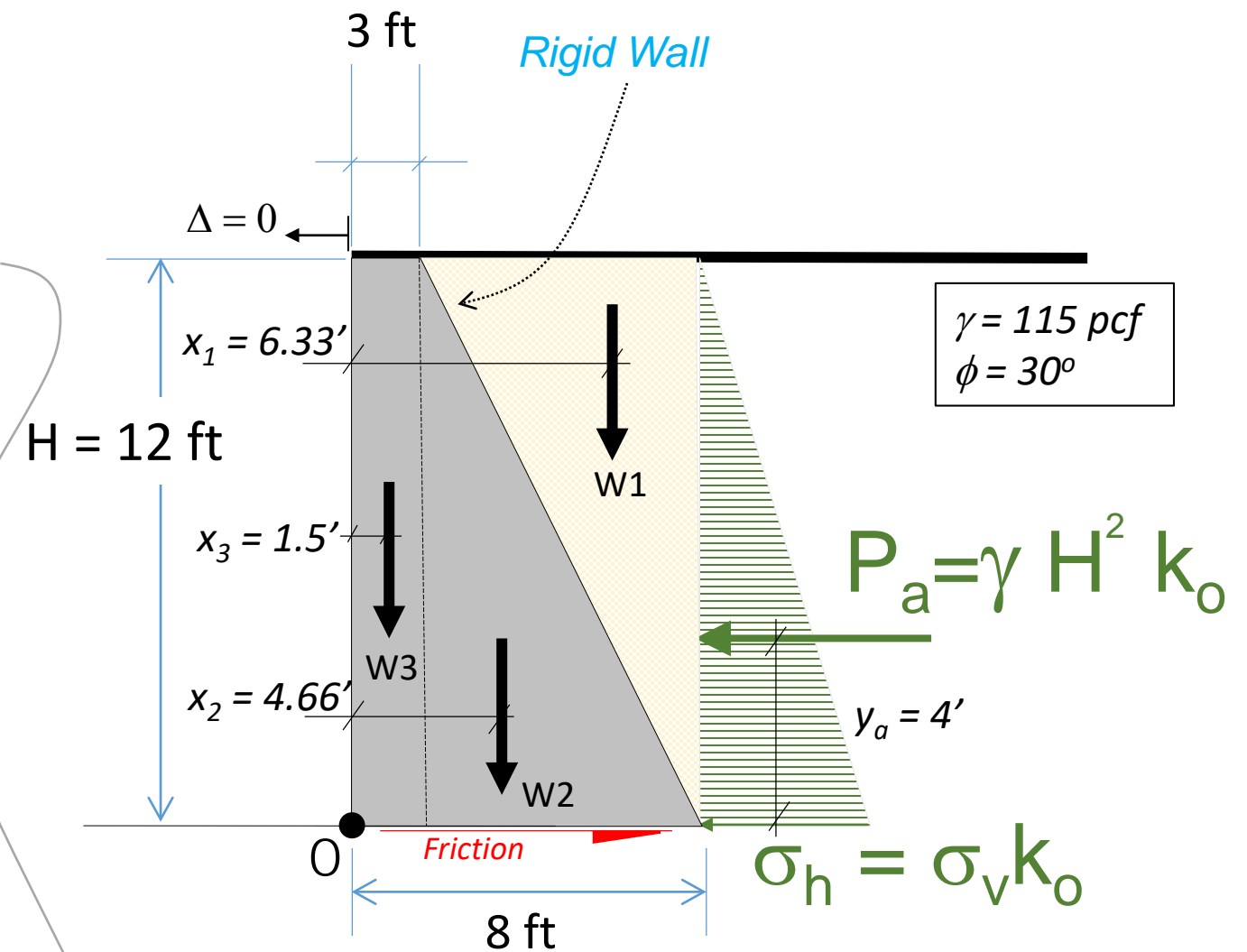
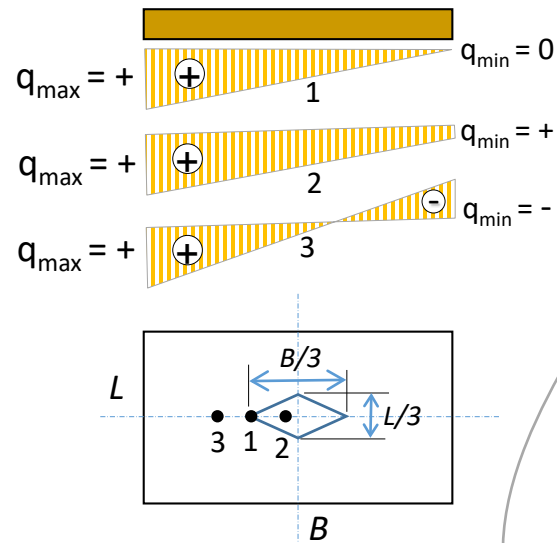

1- Factor of Safety Against Sliding

$$FS_{(sliding)} = \frac{\sum V \tan(20) + P_p}{P_a} \quad P_p = 0$$

$$= \frac{[(13350) \tan 20^\circ]}{4140} = 1.2 > 1.5 \text{ Not OK}$$

2- Factor of Safety Against Overturning

$$FS_{(overturning)} = \frac{\sum M_R}{M_D} = \frac{50908.5}{16560} = 3.1 > 2 \text{ OK}$$

3- Factor of Safety Bearing Capacity Failure = $FS_{(BC)}$

$$M_{net} = \sum M_R - \sum M_D = 50908.5 - 13350 = 37558.5 \text{ ft.lb/ft}$$

$$M_{net} = 37,558.5 = \sum F_y(X) = 13350 (X)$$

$$X = (M_{net} / \sum F_y) = 2.81 \text{ ft}$$

$$e = (8/2) - 2.81 = 1.18 \text{ ft} < B/6 \text{ or } 8/6 = 1.33 \text{ (Full contact)}$$

$$q_{max} = \frac{\sum F_y}{B} \left(1 + \frac{6e}{B}\right) = \frac{13350}{8} \left(1 + \frac{(6)(1.18)}{8}\right) = 3145.6 \frac{\text{lb}}{\text{ft}^2} > q_{all} = 3,000 \frac{\text{lb}}{\text{ft}^2}$$

$$q_{min} = \frac{\sum F_y}{B} \left(1 - \frac{6e}{B}\right) = \frac{13350}{8} \left(1 - \frac{(6)(1.18)}{8}\right) = 192 \frac{\text{lb}}{\text{ft}^2}$$

X - Force (lb)/ft	Vertical Distance (ft)	F_y (lb)/ft	Moment Arm X (ft)	Driving Moment (ft.lb)/ft	Resisting Moment (ft.lb)/ft
$P_a = 4,140$	4			$4,140 \times 4 = 16,560$	
		$W_1 = 0.5 \times 5 \times 12 \times 115 = 3,450$	6.33		$3,450 \times 6.33 = 21,838.5$
		$W_2 = 0.5 \times 5 \times 12 \times 150 = 4,500$	4.66		$4,500 \times 4.66 = 20,970$
		$W_3 = 3 \times 12 \times 150 = 5,400$	1.5		$5,400 \times 1.5 = 8,100$
$P_p = 0$	0				0
		13,350		16,560	50,908.5

Active & Passive Earth Pressure in ϕ – Soil

Example -2

Given:

- Vertical retaining wall (flexible)
- Wall height (H) = 12 ft
- Backfill unit weight (γ) = 115 pcf
- Angle of soil friction (ϕ) = 30°
- Assume wall to be smooth
- $\gamma_{\text{concrete}} = 150 \text{ lb/ft}^3$
- D = 4 ft

Find:

- Resultant Force of the Wall

Solution:

$$\sigma_h = \sigma_v k_a$$

$$K_a = \frac{1 - \sin\phi}{1 + \sin\phi} \quad K_p = \frac{1 + \sin\phi}{1 - \sin\phi}$$

$$P_a = 0.5 \gamma H^2 k_a$$

$$P_a = 0.5 \times 12^2 \times 115 \times 0.33 = 2,732.4 \text{ lb/ft}^2$$

$$P_p = 0.5 D^2 \gamma k_p$$

$$P_p = 0.5 \times 4^2 \times 115 \times 3 = 2,760 \text{ lb/ft}^2$$

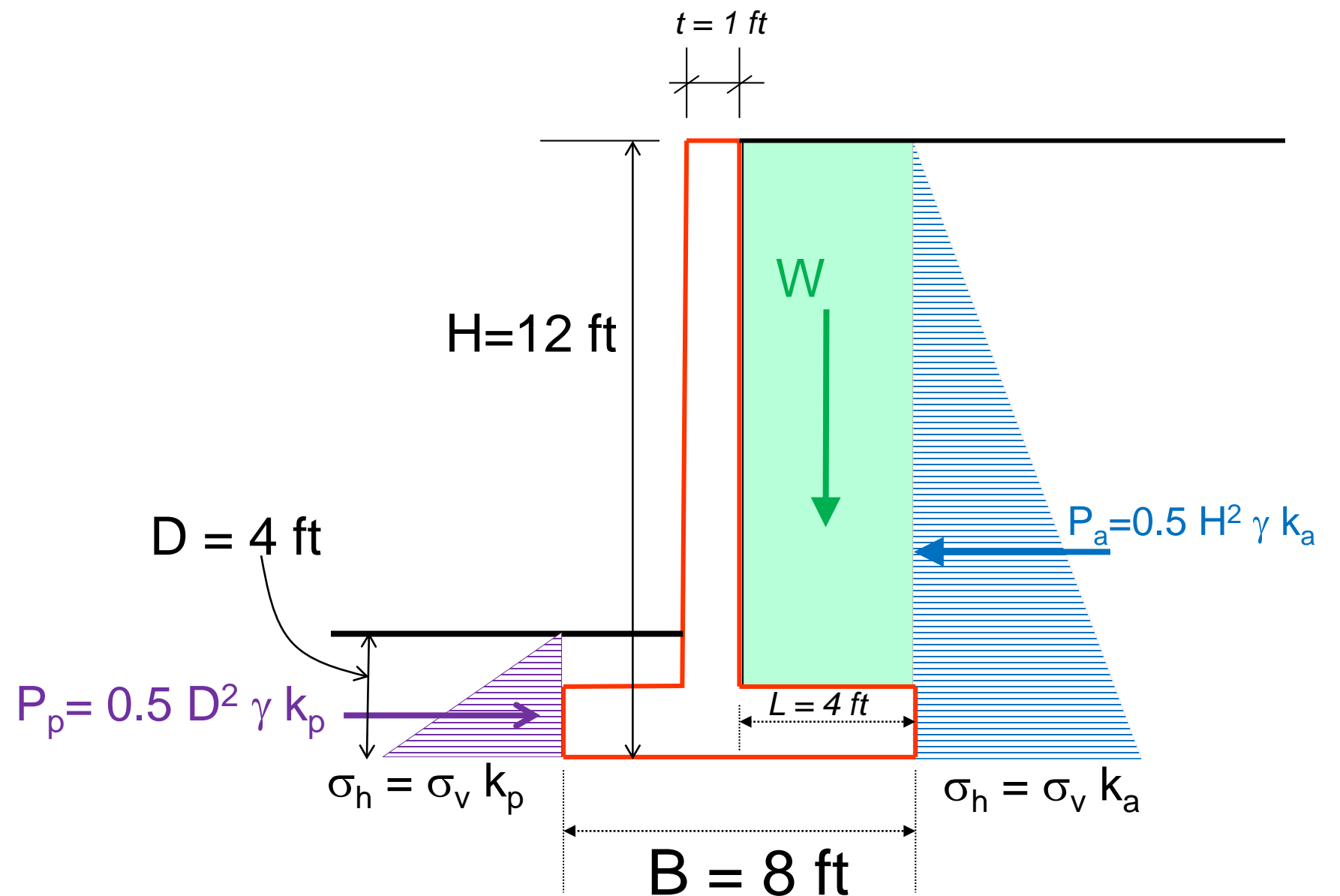

F_x (lb)/ft	Y (ft)	F_y (lb)/ft	Moment Arm X (ft)	Driving Moment (ft.lb)/ft	Resisting M (ft.lb)/ft
$P_a = 2,732.4$	4			$2,732.4 \times 4 = 10,929.6$	
		$W_1 = 4 \times 10 \times 115 = 4,600$	6		$4600 \times 6 = 27,600$
		$W_2 = 1 \times 10 \times 150 = 1,500$	3.5		$1,500 \times 3.5 = 5,250$
		$W_3 = 8 \times 1 \times 150 = 1,200$	4		$1,200 \times 4 = 4,800$
		$W_4 = 2 \times 3 \times 115 = 690$	1.5		$690 \times 1.5 = 1,035$
$P_p = 2,760$	1.33				$2,760 \times 1.33 = 3,680$
		7,990		10,929.6	42,365

1- Factor of Safety Against Sliding = $FS_{(sliding)} = \frac{\sum F_y \tan(20) + P_p}{P_a} = \frac{[(7,990) \tan 20^\circ] + 2,760}{2,732.4} = 2.1 > 1.5 \text{ OK}$

2- Factor of Safety Against Overturning = $FS_{(overturning)} = \frac{\sum M_{Resisting}}{M_{Driving}} = \frac{42,365}{10,929.6} = 3.8 > 2 \text{ OK}$

3- Factor of Safety Bearing Capacity Failure = $FS_{(BC)}$

$$M_{net} = \sum M_r - \sum M_o = 42,365 - 10,929.6 = 31,435.4 \text{ ft.lb/ft}$$

$$M_{net} = 31,435.4 = \sum F_y(X) = 7,990.(X)$$

$$X = (M_{net} / \sum F_y) = 3.93 \text{ ft}$$

$$e = (8/2) - 3.93 = 0.0656 \text{ ft} < B/6 \text{ or } 8/6 = 1.33 \text{ (Full contact)}$$

$$q_{max} = \frac{\sum F_y}{B} \left(1 + \frac{6e}{B}\right) = \frac{7,990}{8} \left(1 + \frac{(6)(0.0656)}{8}\right) = 1,047.8 \frac{\text{lb}}{\text{ft}^2} < q_{all} = 3,000 \frac{\text{lb}}{\text{ft}^2}$$

$$q_{min} = \frac{\sum F_y}{B} \left(1 - \frac{6e}{B}\right) = \frac{7,990}{8} \left(1 - \frac{(6)(0.0656)}{8}\right) = 949.6 \frac{\text{lb}}{\text{ft}^2}$$

$$q_{max} = 1,047 \frac{\text{lb}}{\text{ft}^2} \quad q_{min} = 949.6 \frac{\text{lb}}{\text{ft}^2}$$

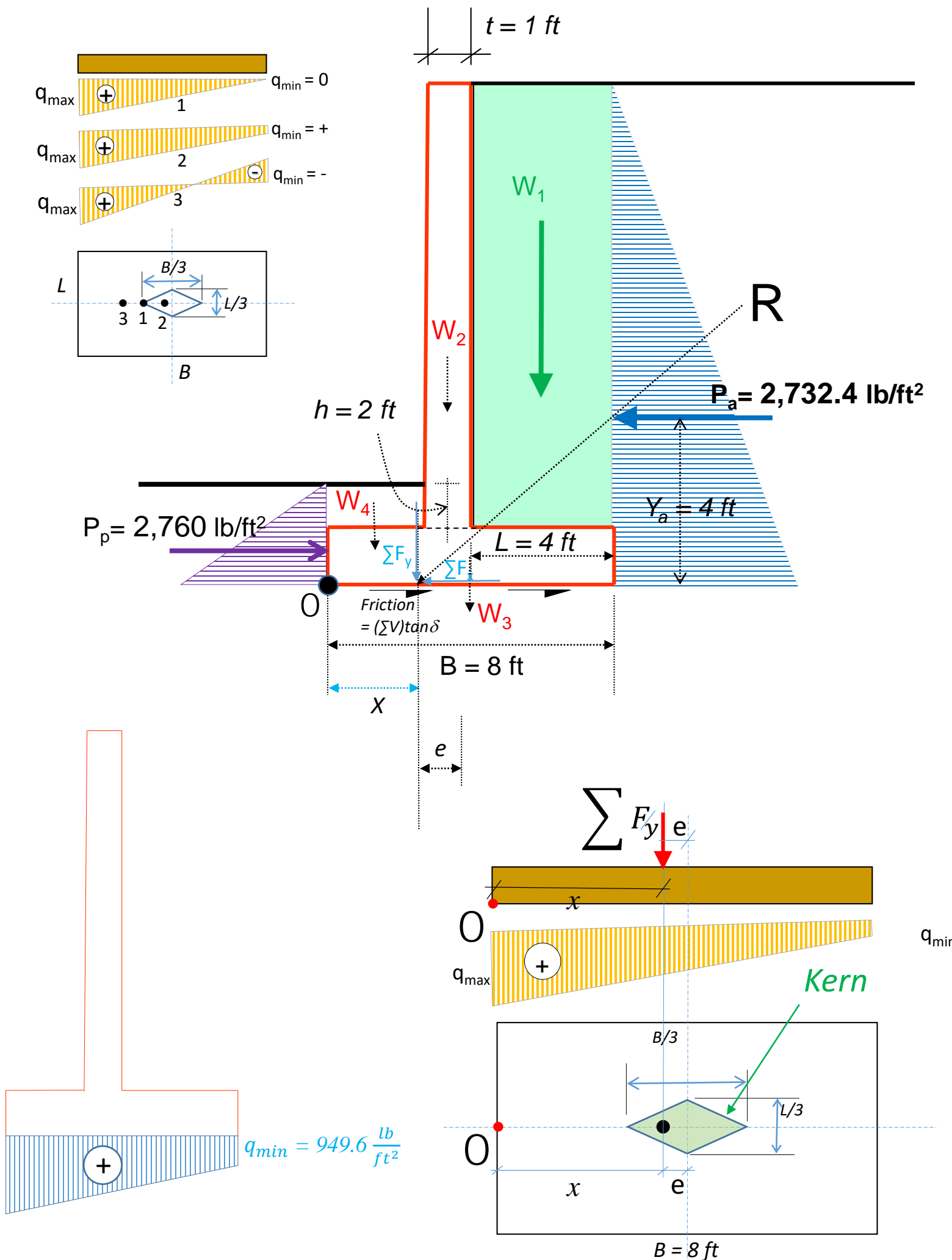

Example 1

Given

The cross section of a cantilever retaining wall is shown in Figure 1. Calculate the factors of safety with respect to overturning, sliding, and bearing capacity.

Solution

From the figure,

$$H^* = H_1 + H_2 + T_1 = 8 \tan 10^\circ + 19.5 + 2 = 22.91 \text{ ft}$$

The Rankine active force per unit length of wall =

$$K_a = \cos \alpha \frac{\cos \alpha - \sqrt{\cos^2 \alpha - \cos^2 \phi}}{\cos \alpha + \sqrt{\cos^2 \alpha - \cos^2 \phi}} \quad K_a = \cos 10^\circ \frac{\cos 10^\circ - \sqrt{\cos^2 10^\circ - \cos^2 30^\circ}}{\cos 10^\circ + \sqrt{\cos^2 10^\circ - \cos^2 30^\circ}} = 0.34$$

P_a = Lateral Pressure from Surcharge + Lateral Pressure from Soil

$$P_{a1} = q H^* k_a$$

$$P_{a2} = \frac{1}{2} \gamma H^{*2} k_a$$

$$P_{a1} = 120 \times 22.9 \times 0.34 = 934.32 \text{ lb/ft}$$

$$P_{v1} = 934.32 \sin(10^\circ) = 162.24 \text{ lb/ft}$$

$$P_{h1} = 934.32 \cos(10^\circ) = 920.13 \text{ lb/ft}$$

$$Y_{a1} = \frac{22.9}{2} = 11.45 \text{ ft}$$

$$P_{a2} = 0.5 \times 115 \times 22.9^2 \times 0.34 = 10252.22 = 11186.54 \text{ lb/ft}$$

$$P_{v2} = 10,252.2 \sin(10^\circ) = 1780.28 \text{ lb/ft}$$

$$P_{h2} = 10,252.2 \cos(10^\circ) = 10096.45 \text{ lb/ft}$$

$$Y_{a2} = \frac{22.9}{3} = 7.63 \text{ ft}$$

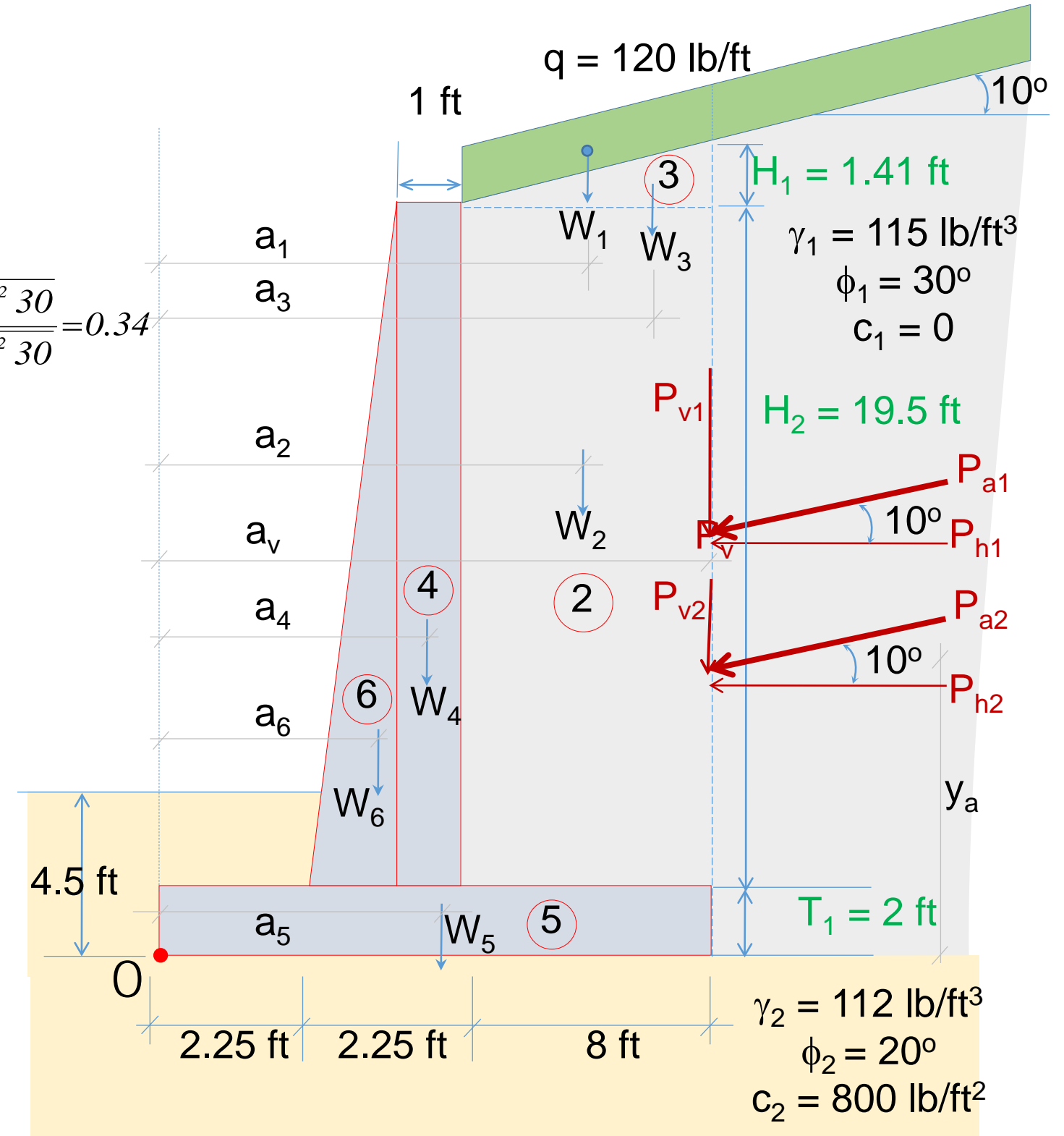

Driving Pressure (lb/ft ²)/ft	Resisting Pressure (lb/ft ²)/ft	Weight/Unit Length (lb/ft)	Moment Arm from Point O (ft)	Driving Moment (ft.lb/ft)	Resisting Moment (ft.lb/ft)
P _{h1} = 920.13			11.45	920.13x11.45 = 10535.49	
P _{h2} = 10096.45			7.64	10096.45x7.64 = 77136.88	
		W ₁ = 120 x 8 = 960	8.5		960x8.5 = 8,160
		W ₂ = 8X19.2X112 = 17,203.2	8.5		17,203.2x8.5 = 146,227.2
		W ₃ = 0.5X1.41X8X112 = 631.7	9.83		631.7x9.83 = 6,209.6
		W ₄ = 1X19.5X150 = 2,925	4.0		2925x4 = 11,700
		W ₅ = 12.5X2X150 = 3,750	6.25		3750x6.25 = 23,437.5
		W ₆ = 0.5X1.25X19.2X150 = 1,800	3.08		1800x3.08 = 5,544
		ΣP _v = 162.24+1780.28 = 1,942.52	12.5		1942.52x12.5 = 24,281.5
ΣP _h = 11,016.58	0	Σ F _y = 29,212.4		ΣM _D = 87,672.37	ΣM _R = 225,559.86

1- Factor of Safety Against Sliding = $FS_{(sliding)} = \frac{\sum F_y \tan(20) + Pp}{P_a} = \frac{[(29,212.4) \tan 20^\circ] + 0}{11,016.58} = 0.96 < 1.5 \text{ Not OK}$

Add Passive Resistance

$P_p = 0.5 \times 4.5^2 \times 115 \times 3 = 3493.13 \text{ lb/ft}$

2- Factor of Safety Against Sliding = $FS_{(sliding)} = \frac{\sum F_y \tan(20) + Pp}{P_a} = \frac{[(29,212.4) \tan 20^\circ] + 3493.13}{11,016.58} = 1.28 < 1.5 \text{ Not OK}$

3- Factor of Safety Against Overturning = $FS_{(overturning)} = \frac{\sum M_R}{\sum M_D} = \frac{225,559.86}{87,672.37} = 2.57 > 2.0 \text{ OK}$

4- Factor of Safety Bearing Capacity Failure = $FS_{(BC)} =$

$$M_{net} = \sum M_R - \sum M_D = 225,559.86 - 87,672.37 = 137,887.5 \text{ ft.lb/ft}$$

$$M_{net} = 137,887.5 = \sum F_y(X) = 29,212.4 (X)$$

$$X = (M_{net} / \sum F_y) = 4.72 \text{ ft}$$

$$e = (12.5/2) - 4.72 = 1.53 \text{ ft} < B/6 \text{ or } 12.5/6 = 2.083 \text{ (Full contact)}$$

$$q_{max} = \frac{\sum F_y}{B} \left(1 + \frac{6e}{B}\right) = \frac{29,212.4}{12.5} \left(1 + \frac{(6)(1.53)}{12.5}\right) = 4053.28 \frac{\text{lb}}{\text{ft}^2} > q_{all} = 3,000 \frac{\text{lb}}{\text{ft}^2} \quad \text{No good}$$

$$q_{min} = \frac{\sum F_y}{B} \left(1 - \frac{6e}{B}\right) = \frac{29,212.4}{12.5} \left(1 - \frac{(6)(1.53)}{12.5}\right) = 621 \frac{\text{lb}}{\text{ft}^2}$$

