

Lastname: _____

**LABORATORY
FFT Filter**

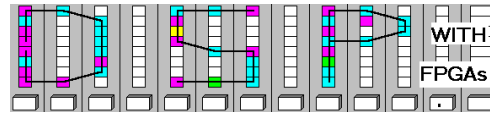

5Digit SS: _____

**LAB FFT: INTRODUCTION TO FAST FOURIER TRANSFORM
(10 points)**

In this lab you will be introduced to the design for a Fast Fourier Transform (FFT). The FFT is one of the most important DSP objects and is used not only to compute an approximation of the Fourier Transform, but also to enable fast convolution, a very time consuming filtering operation when done in time domain. In the **pre-lab** you will compute with “pencil-and-paper” the results you later expect in your design implementation. In the **design part** you will design an 8 point radix-2 FFT using the principle of decimation in frequency.

Lab Objectives

After completing this lab you should be able to

- Develop a radix-2 FFT and compute test data
- Understand the difference between DFT and FFT
- Design and simulate FFT using the principle of decimation in frequency using Simulink

Pre-lab (3 points)

The following figure shows the 8 point radix-2 FFT using the principle of decimation in frequency:

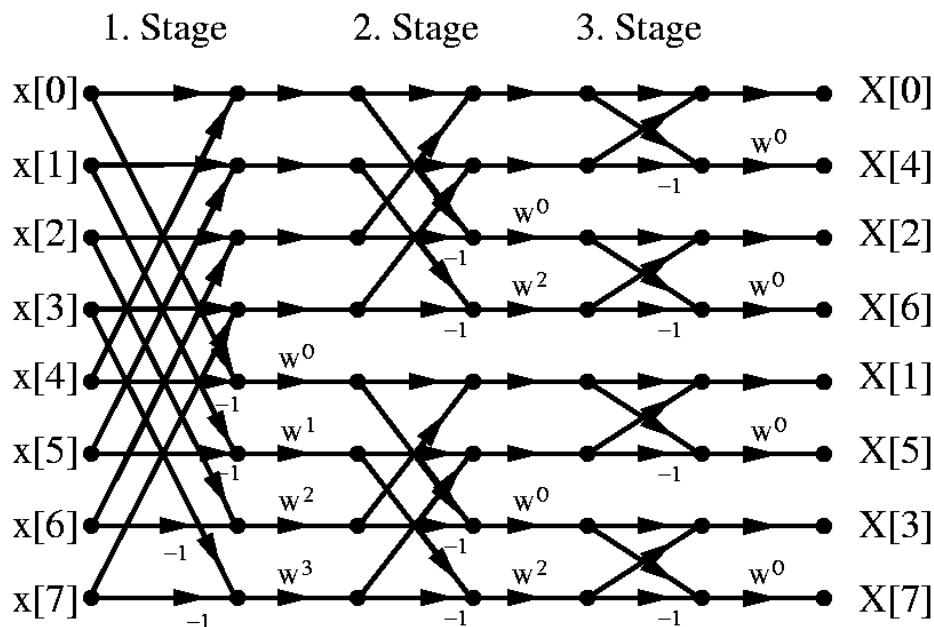
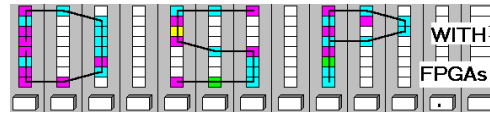

Fig. 1

Lastname: _____

**LABORATORY
FFT Filter**



5Digit SS: _____

- From the signal flow graph in Fig.1, determine for each stage the number of blocks required from each type of butterfly.

	1. stage	2. stage	3. stage
Butterfly with w^0			
Butterfly with w^1			
Butterfly with w^2			
Butterfly with w^3			

- Redraw the radix-2 signal flow graph from Fig.1 such that the butterfly operations do not overlap and input/output are in natural rather than bit-reverse order, by completing the following figure:

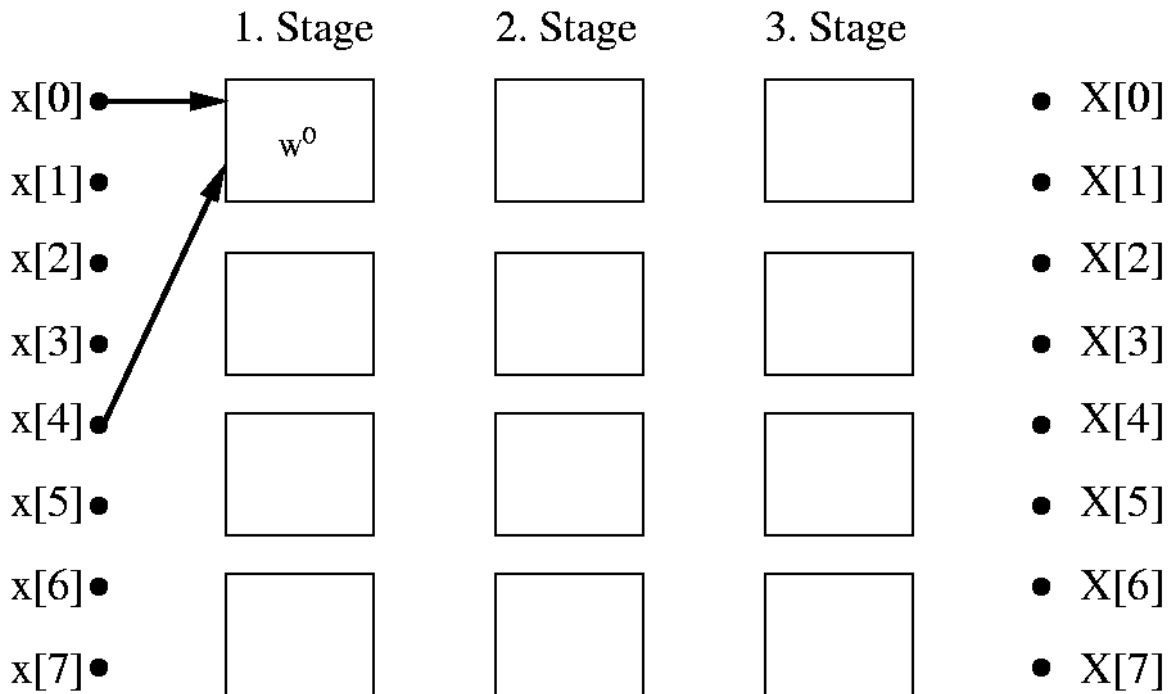

Fig. 2

- Each butterfly $k \in [0,3]$ performs a complex value operation of the type $D = A+B$; and $E = (A-B)W^k$

Complete the following table for the given input values (1 extra point)

	A	B	D	E
Butterfly with w^0	2	10		
Butterfly with w^1	4	12		
Butterfly with w^2	6	14		
Butterfly with w^3	8	16		

Hint: Use a pocket calculator or MatLab for w^1 or w^3

- Using MatLab, compute for $x=2:2:16$ the FFT, $X = \text{fft}(x)$, and complete the following table:

	X[0]	X[1]	X[2]	X[3]	X[4]	X[5]	X[6]	X[7]
Real								
Imag								

Lastname: _____

LABORATORY FFT Filter

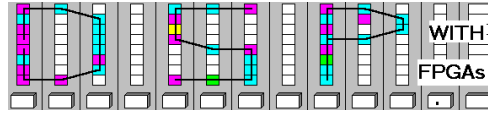



5Digit SS: _____

Simulink Design-lab (7 points)

Follow the directions below to implement the 8-point radix-2 FFT circuit.

A. Getting Started

If you are in room B114 or the digital logic lab:

1. On the desktop, double click on the **Engineering Folder**.
2. Double click on the MatLab icon  to start MatLab. It will take a few seconds to load.
3. From the top icon list in the **MatLab** window click on the **Simulink** icon  to start **Simulink**.
4. Create a New Folder on your mapped network drive and name it **DSPwFPGAs**. Use this folder to save your designs. **Never** save your files to the local drive, use your **network drive** or a **USB drive** instead.

B. Design the W1 and W3 Butterflies

1. Download the file **dif8.mdl** from the class webpage and place it in your **DSPwFPGAs** folder.
2. Click on the "Current Directory" selection icon  and select as current directory your **DSPwFPGAs** folder.
3. The files in the **DSPwFPGAs** folder will now be **visible** in the **upper left** MatLab window. Double click on the **dif8.mdl** file. After a moment, you should see the incomplete design shown in the figure below.

Lastname: _____

5Digit SS: _____

LABORATORY FFT Filter

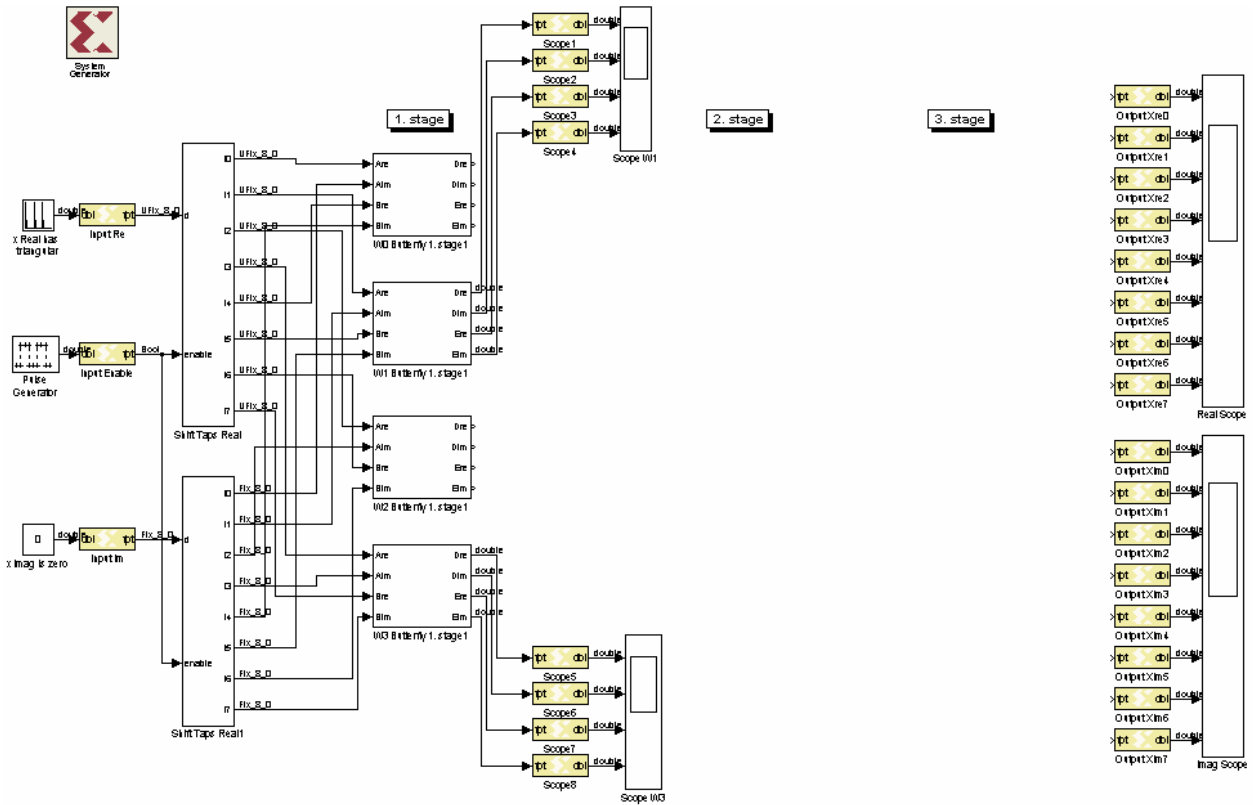
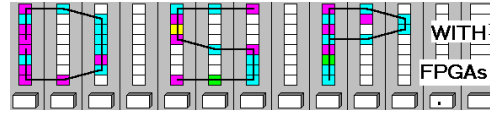

4. Complete the butterfly blocks w^1 and w^3 such that you match the values computed in the pre-lab, $D=16$ $E=-6+j6$ for w^1 and $D=24$ $E=6+j6$ for w^3 . Simulate your design and compare the results shown by the provided scopes for w^1 and w^3 with the data you computed for the pre-lab. To do so, you will have to temporarily delete the output gateways for the overall design as Simulink will not successfully simulate with “unconnected inputs.” Remember that you may use the 3*/5+ complex multiplier block you used in lab 7.
5. Print out the simulation waveform for w^1 and w^3

C. Completion of the 8-point radix-2 FFT

1. Complete your design using the signal flow graph you developed in the pre-lab.
2. Copy and paste the necessary 8 additional subsystems and then wire them as determined in the pre-lab.
3. Simulate your design and compare the results shown by the provided scopes with the data you computed for the pre-lab. Check that both the real and imaginary parts are correct. Print the simulation waveform for the real and imaginary parts.
4. Using the **System Generator**, create the Xilinx **project files** for your design.

Lastname: _____

**LABORATORY
FFT Filter**

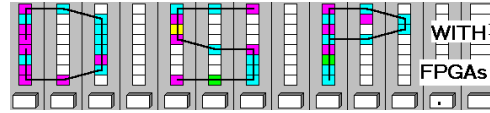

5Digit SS: _____

5. Repeating the steps followed during previous labs, open the **Project Navigator**, **compile** your project and verify the **results** from the **Design Summary** in order to complete the following:

Total 4 input LUTs = _____

Max. Freq. = _____

18X18 Multipliers = _____

Block RAMs = _____

F. Deliverables:

1. Solve the problems of the pre-lab. (3 points).
2. Print the MDF file and the Simulink simulation (7 points).

Make sure your name and SS is on all pages you turn in!