

Mechanics & Materials 1

Chapter 11

Torsion

FAMU-FSU College of Engineering
Department of Mechanical Engineering

Torsion

- Torsion refers to the twisting of a structural member when it is loaded by couples that produce rotation about the longitudinal axis
- The couples that cause the tension are called Torques, Twisting Couples or Twisting Moments

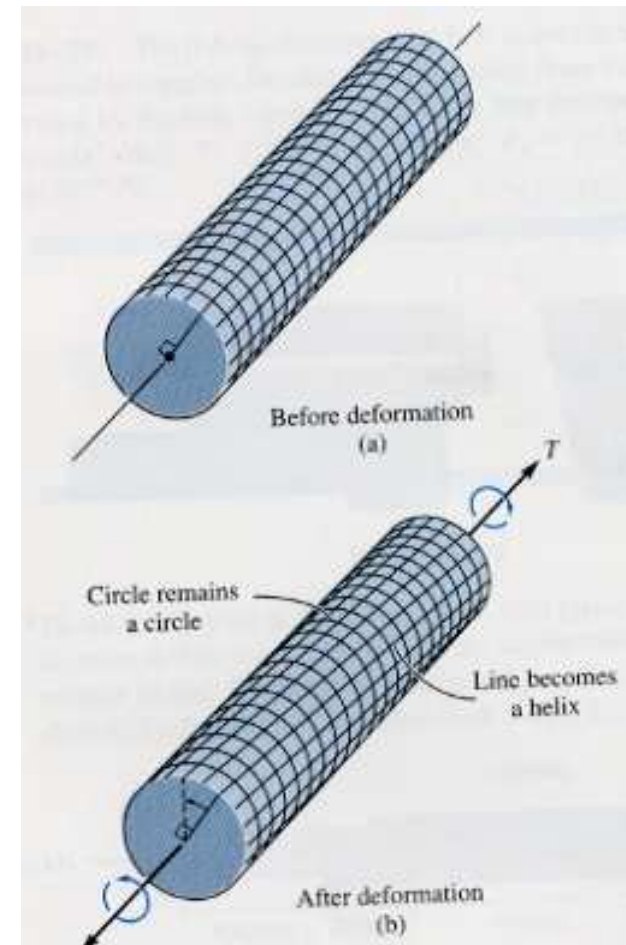

Torsion of Circular Bar

- From consideration of symmetry:
 - Cross sections of the circular bar rotates as rigid bodies about the longitudinal axis
 - Cross sections remain straight and circular

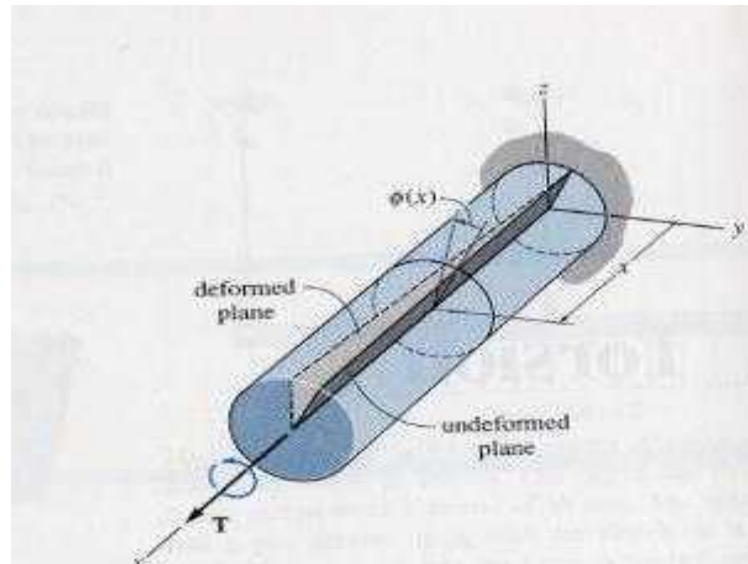

Torsion of Circular Bars

- If the right hand of the bar rotates through a small angle ϕ
 - ϕ : angle of twist
- Line will rotate to a new position

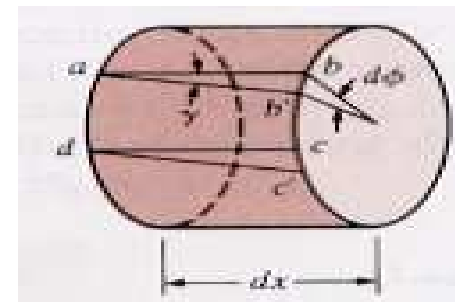
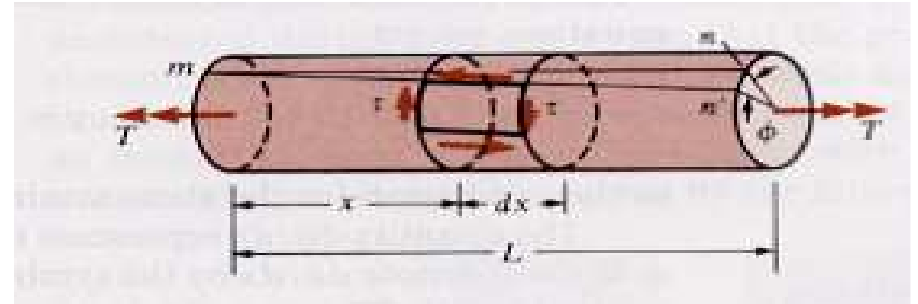

- The element ABCD after applying torque

$b \rightarrow b'$
 $d \rightarrow d'$

\longrightarrow Element in state of “pure shear”

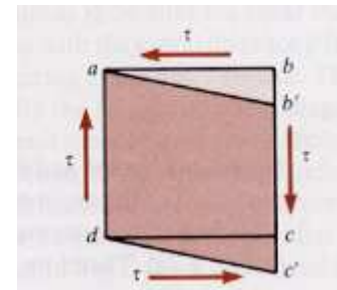

Shear Strain

- During torsion, the right-hand cross section of the original configuration of the element (abcd) rotates with respect to the opposite face and points b and c move to b' and c'.
- The lengths of the sides of the element do not change during this rotation, but the angles at the corners are no longer 90°. Thus, the element is undergoing pure shear and the magnitude of the shear strain is equal to the decrease in the angle bab'. This angle is

$$\tan \gamma = \frac{bb'}{ab}$$

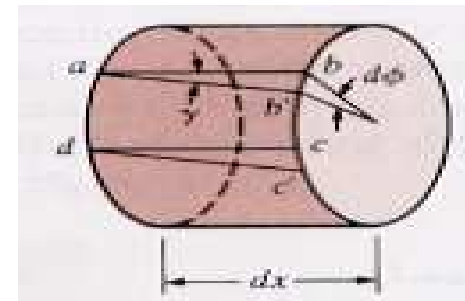

Shear Strain γ

$\tan\gamma \approx \gamma$ because under pure torsion the angle γ is small. So

$$\gamma = \frac{bb'}{ab} = \frac{rd\phi}{dx}$$

Under pure torsion, the rate of change $d\phi/dx$ of the angle of twist is constant along the length of the bar. This constant is equal to the angle of twist per unit length θ .

$\frac{d\phi}{dx} \rightarrow$ rate of change of the angle of twist ϕ

$\frac{d\phi}{dx} = \theta \rightarrow$ Angle of twist per unit length

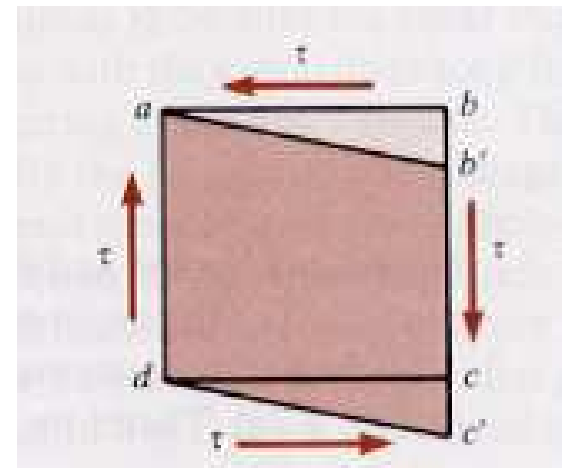

Shear Strain

$$\gamma = \frac{\rho d\phi}{dx} = \rho\Theta$$

- Since every cross section is subjected to the same torque so $d\phi/dx$ is constant, the shear strain varies along the radial line

$\gamma = 0$ at $\rho = 0$ (center of shaft)

$\gamma = \text{maximum}$ at $\rho = C$ (outer surface of shaft)

$$\frac{d\phi}{dx} = \frac{\gamma}{\rho}$$

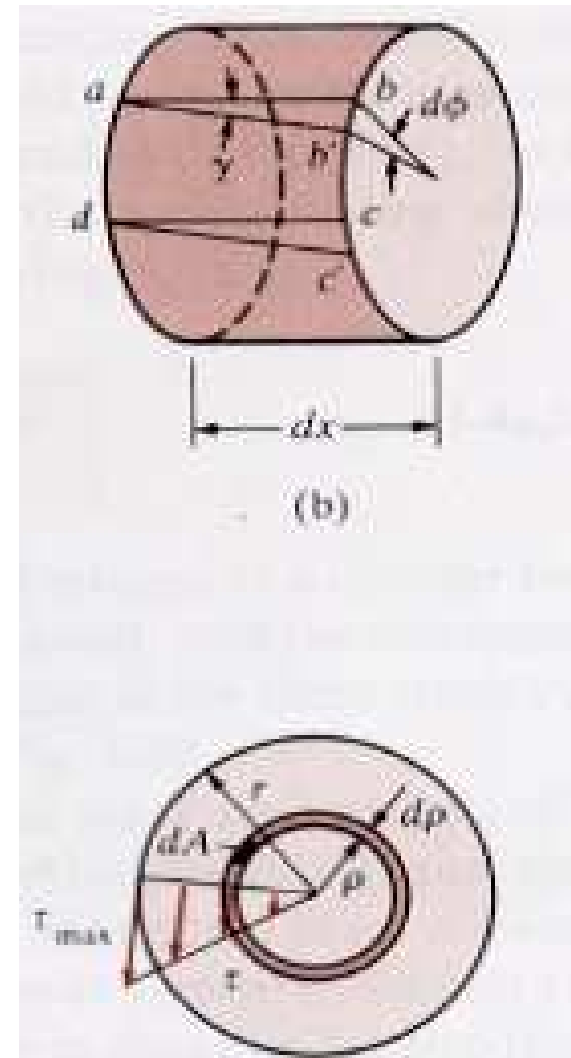

Shear Strain

since

$$\frac{d\phi}{dx} = \text{const}$$



The shear strain within the shaft varies linearly along any radial line, from zero at the axis of the shaft to a maximum to at its outer surface

$$\frac{d\phi}{dx} = \frac{\gamma_{\max}}{C}$$

hence

$$\frac{d\phi}{dx} = \frac{\gamma}{\rho} = \frac{\gamma_{\max}}{C}$$

$$\gamma = \left(\frac{\rho}{C} \right) \gamma_{\max}$$

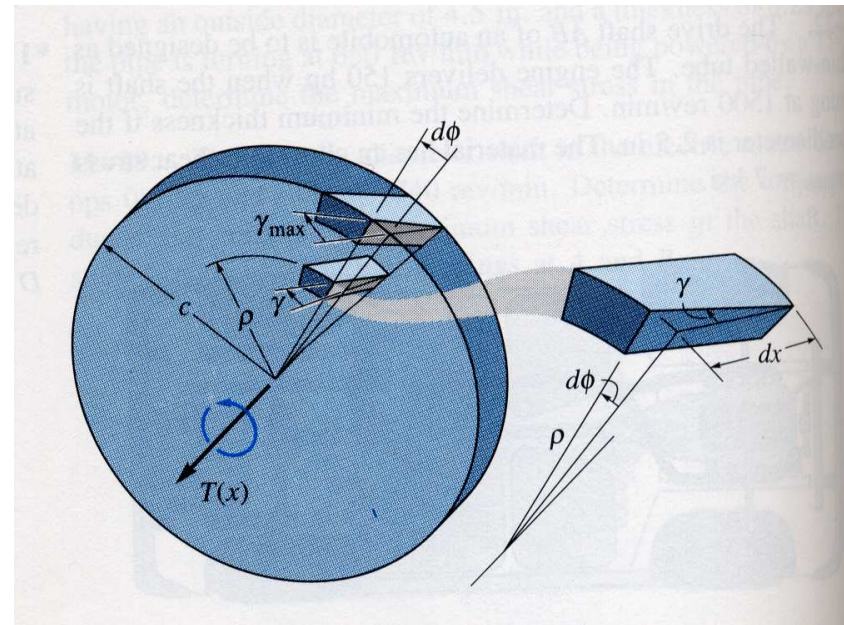

Pure Torsion

In the case of pure torsion the rate of change $\frac{d\phi}{dx}$

is constant along the length of the bar, because every cross section is subjected to the same torque.

Therefore, we obtain

$\theta = \frac{\phi}{L}$, where L is the length of the shaft

Equation $\gamma = r\theta$ becomes

$$\gamma = r\theta = \frac{r\phi}{L}$$

THEORY OF TORSION FORMULA

- **The following conditions are used in the torsion of the circular shaft:**
 1. Sectional planes perpendicular to the axis of the shaft remain plane during torque application.
 2. The shear strain varies linearly from a value of zero at the axis of the shaft to a maximum at the extreme radius .
 3. For linearly elastic materials, Hook's Law is applicable and shear stress is linearly proportional to shear strain.

Torsion Formula

•If the external torque applied to shaft in equilibrium requires internal torque inside the shaft

Hook's Law of Torsion

$$\tau = G\gamma = G\rho\theta$$

τ : shear stress

G : shear modulus (modulus of rigidity)

γ : Shear strain

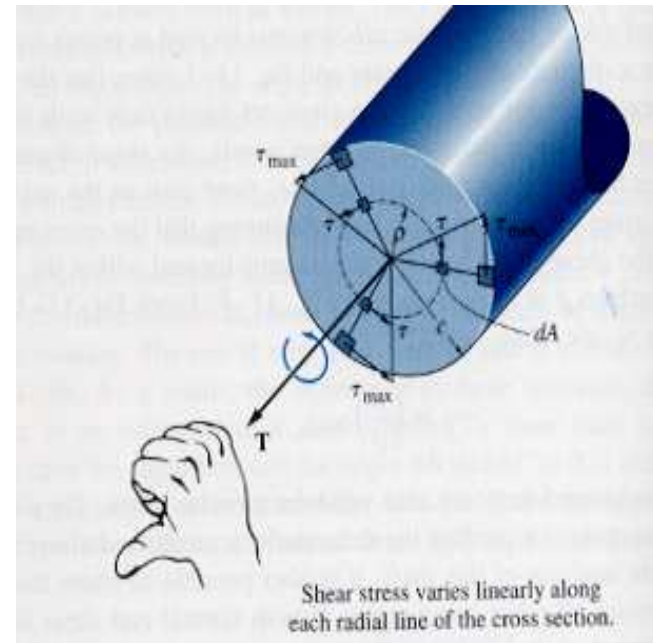

Torsion Formula: Shear Stress

- From Hook's law for shear, if the material behavior is *linear-elastic* then a *linear variation in shear strain* leads to *linear variation in shear stress*. So the shear stress for a solid shaft will vary from zero at the shafts longitudinal axis to a maximum value τ_{\max} at its outer surface such that:

$$\tau = \left(\frac{\rho}{c} \right) \tau_{\max}$$

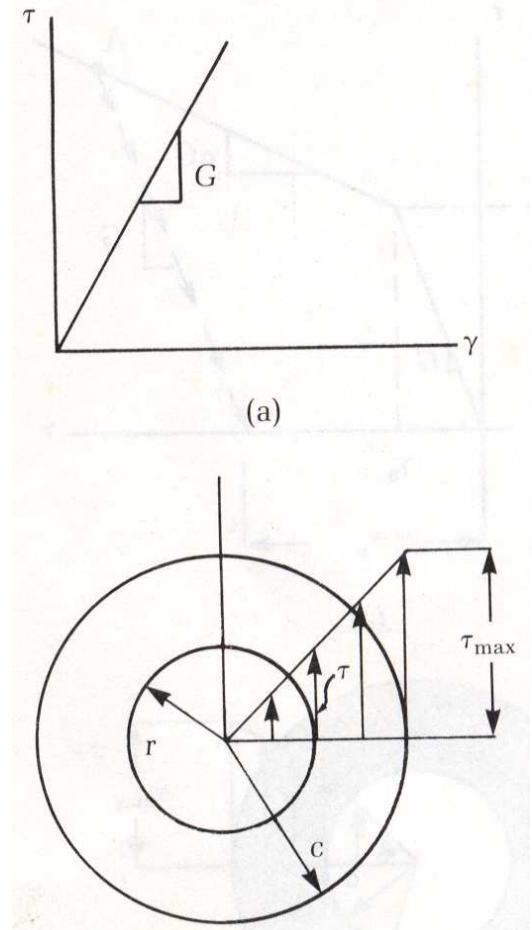

Torsion Formula: Shear Stress

- The shear stress depends on both the Torque and the cross section Moment of inertia; for circular shafts that moment of inertia is referred to as polar Moment of Inertia, J

$$\tau = \frac{T \cdot \rho}{J}$$



$$\tau_{\max} = \frac{T \cdot c}{J}$$

T : The resultant internal torque acting at the cross section

J : Polar moment of Inertia of cross section

ρ : The radius measured from the center of the shaft

c : The outer radius of the shaft

Polar Moment of Inertia : J

- For Solid Shaft

$$J = \frac{\pi}{2} c^4$$

- For Tubular Shaft

$$J = \frac{\pi}{2} (c_o^4 - c_i^4)$$

- J is always positive
- Units for J (length)⁴: m⁴, mm⁴, in⁴, etc.

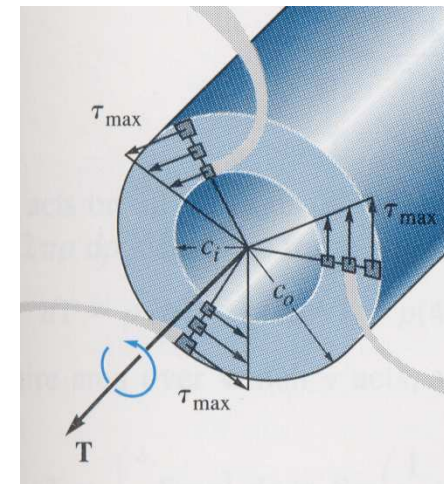
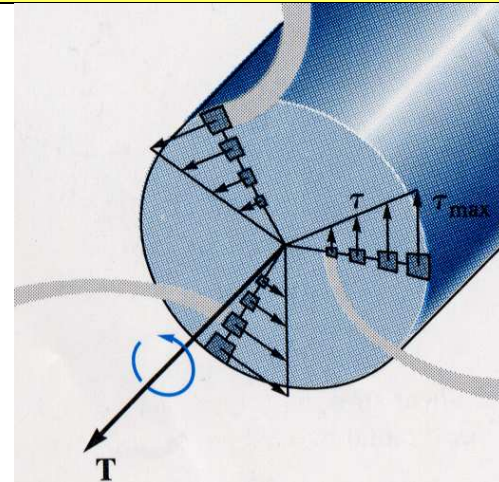

Power Transmission

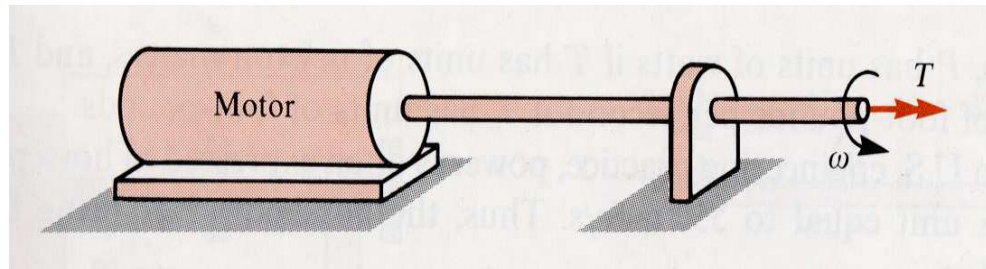

- Shafts mainly used to transmit mechanical power from one machine to another
- Power (P) : work performed per unit time.
- During instant of time dt an applied torque T will cause the shaft to rotate dθ so

$$P = T \frac{d\theta}{dt} = T \cdot \omega$$

- ω: shafts angular velocity(rad/s)

Power Transmission

- Power units: SI: Watt (N.m/s), fps: (ft.lb/s)
- 1horsepower=550 ft.lb/s
- The shafts angular speed is given in terms of frequency f which is a measure of the number of revolutions or cycles the shaft makes per second

$$\omega = 2\pi f \Rightarrow P = 2\pi fT$$

- In terms of the number of revolutions per minute(rpm)

$$n = 60 f$$

$$P = \frac{2\pi nT}{60} (n = rpm)$$

Shaft Design

- From the power transmitted by the shaft and its frequency of rotation we can find the torque ,

$$T = \frac{P}{2\pi f}$$

- Knowing T and the allowable shear stress for the material; τ_{allow} we can determine the size of the shaft's cross section using the torsion formula, assuming linear elastic behavior

$$\frac{J}{c} = \frac{T}{\tau_{allow}}$$

- The design geometric parameter is J/c , J : polar moment of inertia, for solid shaft and c is the radius, for hollow shaft we need c_{in} and c_{out} , so we assume one and find the other

$$\text{solid shaft} \rightarrow J = \frac{\pi}{2} c^4$$

$$\text{hollow shaft} \rightarrow J = \frac{\pi}{2} (c_o^4 - c_i^4)$$

Angle of Twist

- The formula for angle of twist is derived by examining an element of the shaft which is dx (infinitesimal) in length. It is known that an arc length equals the subtended angle times the radius of the arc: $d = \phi r$
- A point on the radius on one end of the element will travel a relative distance, i.e. create an arc length, equal to the angle $\gamma_{\max} dx$.

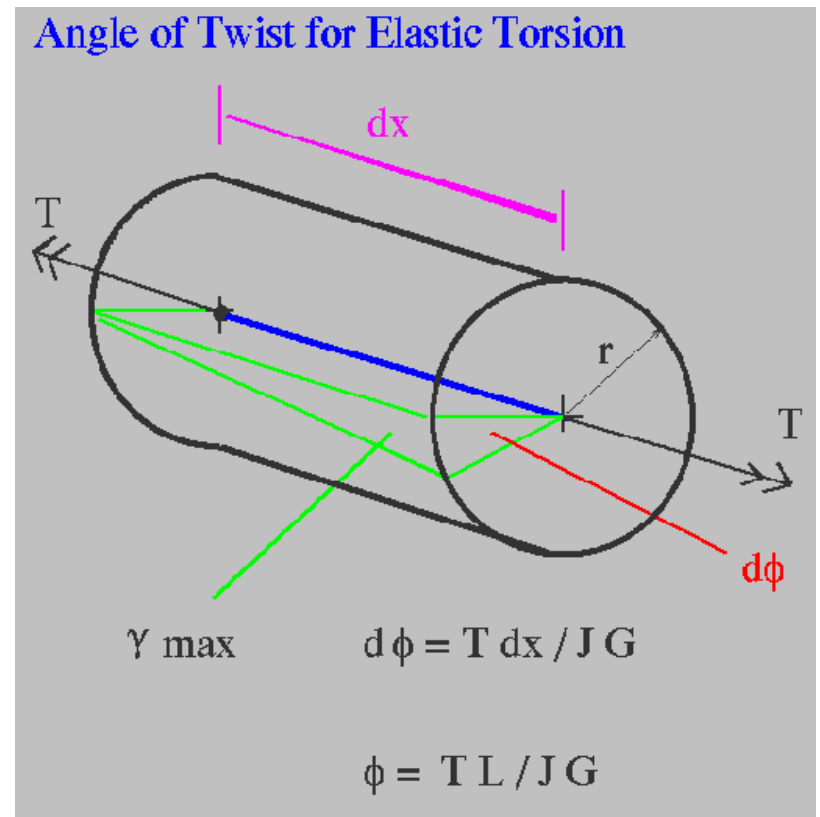

$$\phi = \frac{T.L}{JG}$$

Angle of Twist

- As shown in the figure, this distance is also equal to the radius time the angle ϕ , where ϕ measures the angle of twist.

- The angle of twist

$$\phi = \frac{T \cdot L}{JG}$$

- G is the modulus of rigidity (shear modulus), J is Polar moment of inertia

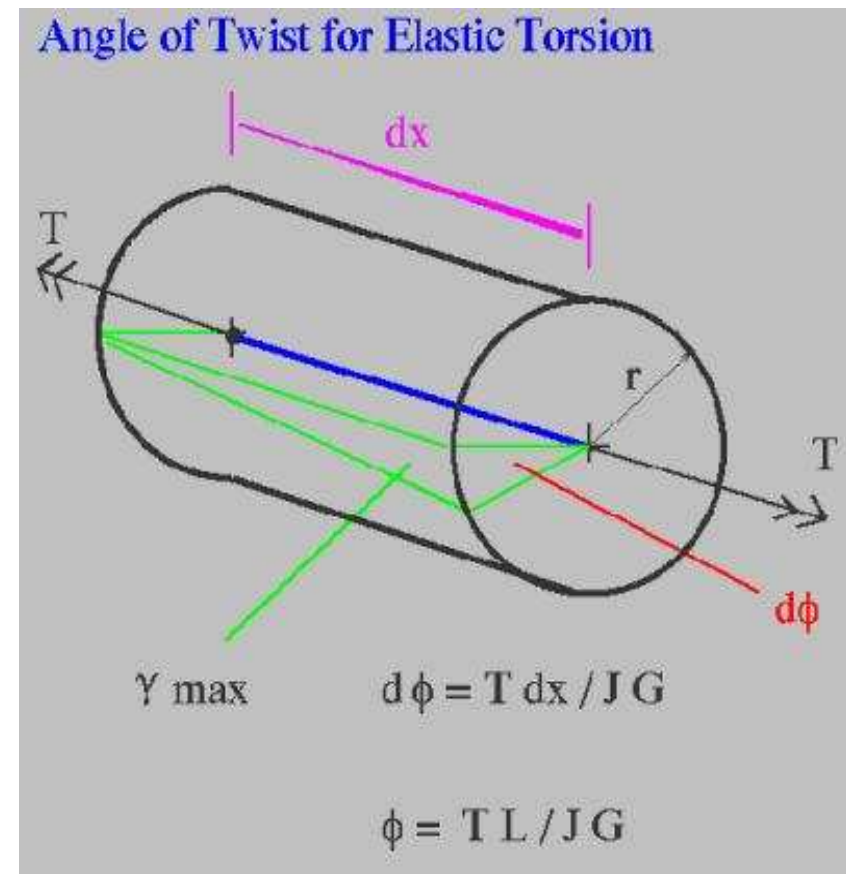

Nonuniform Torsion

A. Discrete Shaft

$$\begin{aligned}\phi &= \phi_1 + \phi_2 + \dots = \frac{T_1 L_1}{G_1 J_1} + \frac{T_2 L_2}{G_2 J_2} + \dots \\ &= \sum_{i=1}^n \frac{T_i L_i}{G_i J_i}\end{aligned}$$

The signs of the torques should be observed

B. Varying cross section shaft

$$d\phi = \frac{T_x dx}{GJ} \Rightarrow \phi = \int_0^L d\phi = \int_0^L \frac{T_x dx}{GJ_x}$$

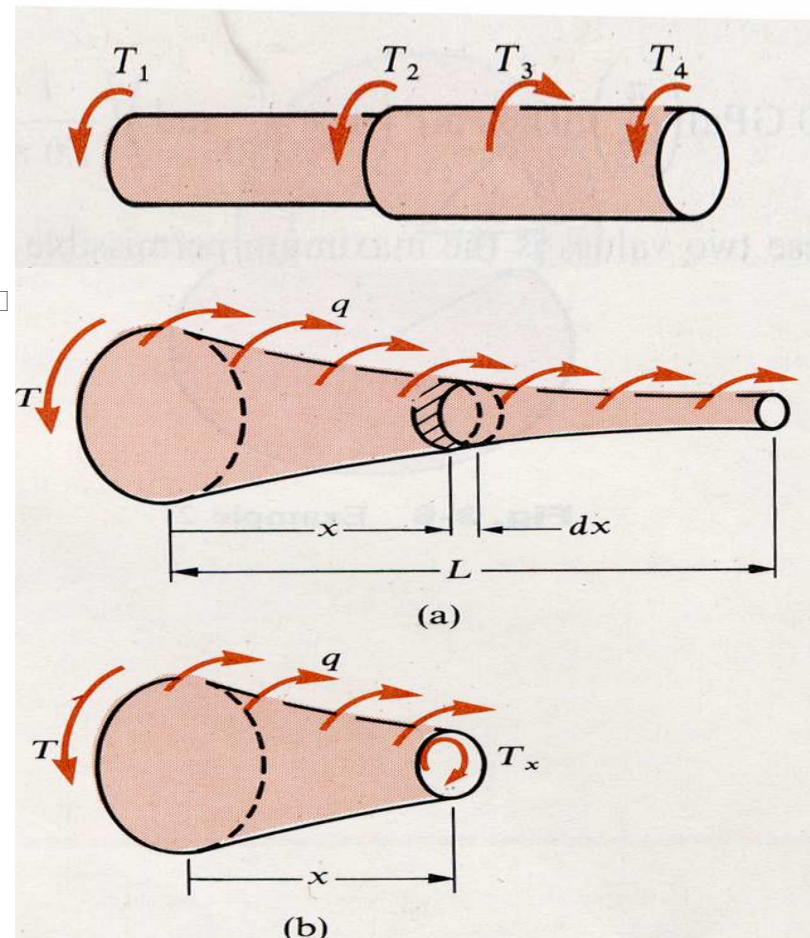

Statically Indeterminate Torsional Members: Uniform Shaft

- Statically Indeterminate Torsional Members: When the moment equation of equilibrium applied about the axis of the shaft is not adequate to determine the unknown torques acting on the shaft.

$$\sum M_x = 0 \rightarrow T - T_A - T_B = 0$$

One Equilibrium Eq
Two Unknowns: T_A & T_B } \rightarrow *Statically Indeterminate*

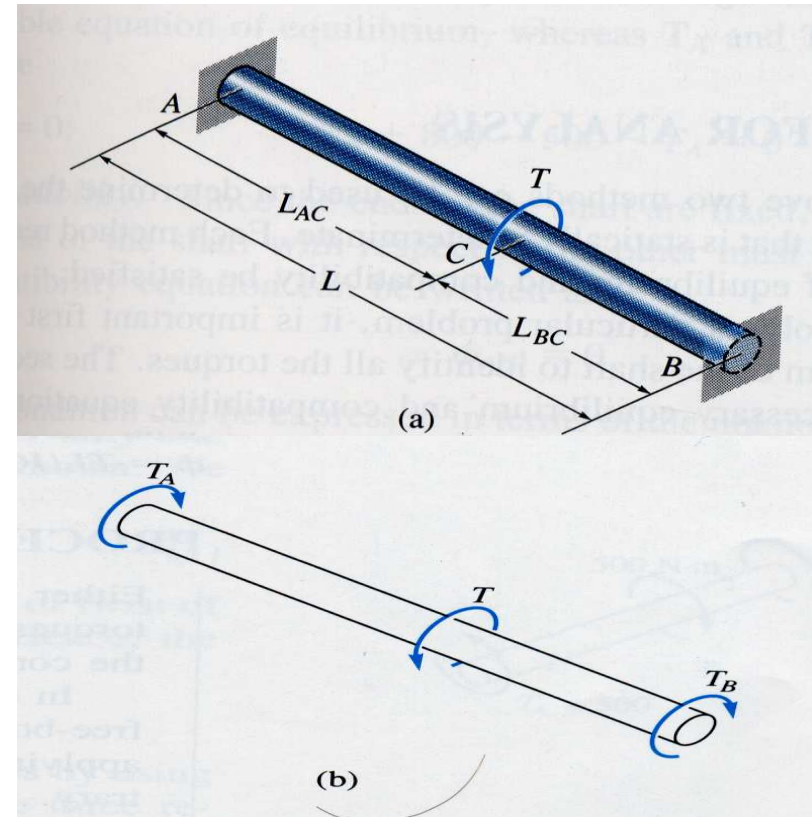

Statically Indeterminate Torsional Members: Uniform Shaft

To solve The problem we transform the compatibility equation into an equation which involves the torques

- Compatibility Condition:

angle of twist of one end of the shaft w.r.t the the other end=0, since the supports are fixed

$$\phi_{A/B} = 0 \rightarrow \phi_{A/C} - \phi_{B/C} = 0$$

$$\frac{T_A L_{AC}}{JG} - \frac{T_B L_{BC}}{JG} = 0$$

substitute $T_A = \frac{T_B L_{BC}}{L_{AC}}$ into the moment equation

$$T_A = T \frac{L_{BC}}{L_{BC} + L_{AC}} = T \frac{L_{BC}}{L}$$

$$T_B = T \frac{L_{AC}}{L_{BC} + L_{AC}} = T \frac{L_{AC}}{L}$$

Superposition of Torque

- We can solve the earlier statically indeterminate problem utilizing the superposition principle, using one torque at each time, while considering the other torque as redundant

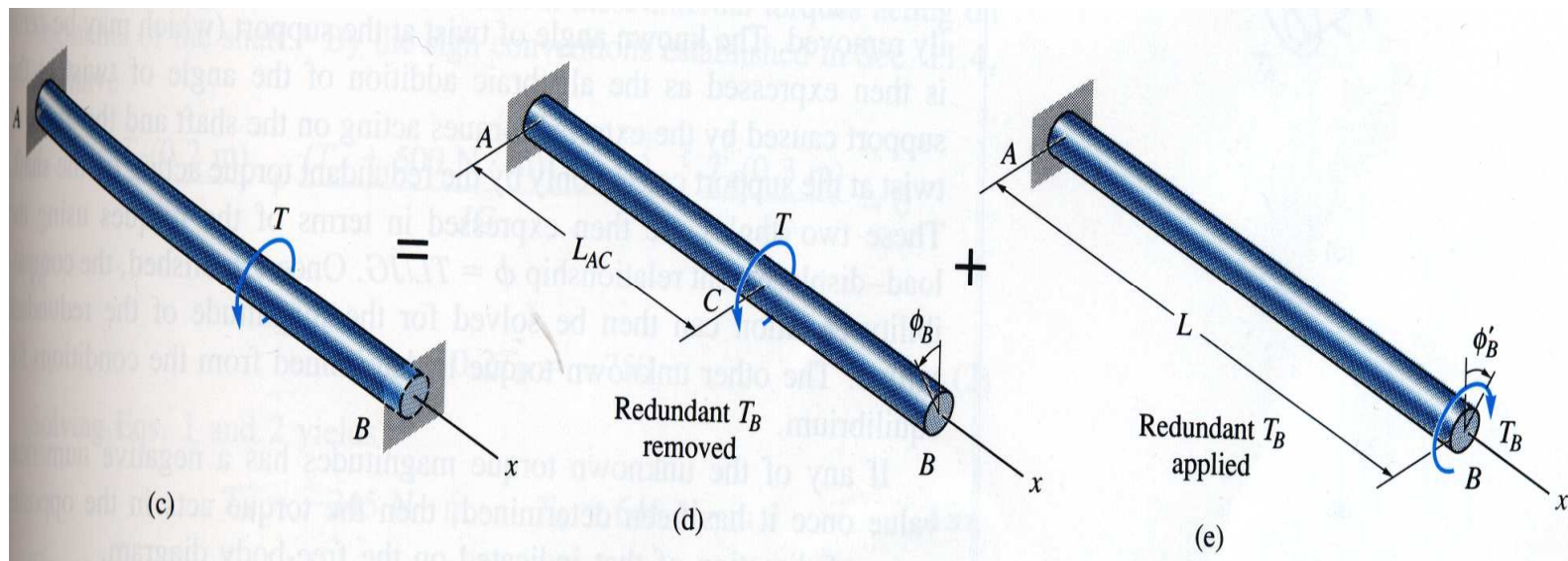

Superposition of Torque

First we load the shaft by applying the external torque T then, the redundant torque T_B is applied to unload the shaft

$$0 = \phi_B - \phi_B'$$
$$0 = \frac{TL_{AC}}{JG} - \frac{T_B L}{JG} \Rightarrow T_B = T \left(\frac{L_{AC}}{L} \right)$$

From the moment equation

$$\sum M_x = 0 \Rightarrow T - T_A - T_B = 0$$

$$T_A = T \frac{L - L_{AC}}{L} = T \frac{L_{BC}}{L}$$

$$T_B = T \frac{L_{AC}}{L}$$

Statically Indeterminate Torsional Members: Nonuniform Shaft

- From static's equilibrium

$$T_a + T_b = T_0$$

- Using the superposition method, selecting the torque T_b as redundant, so that the released structure is obtained by removing support B

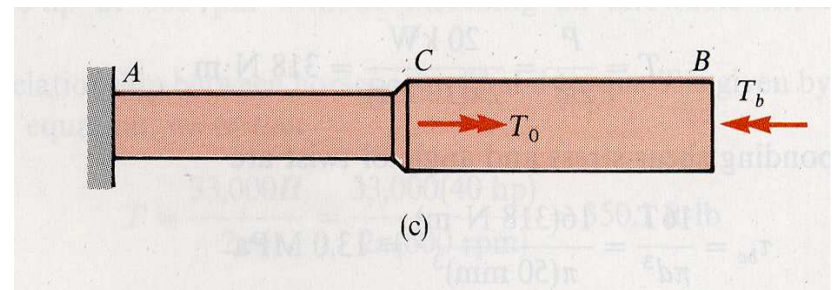
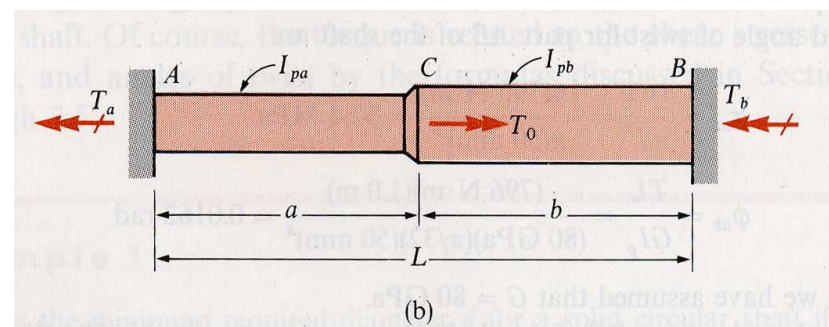
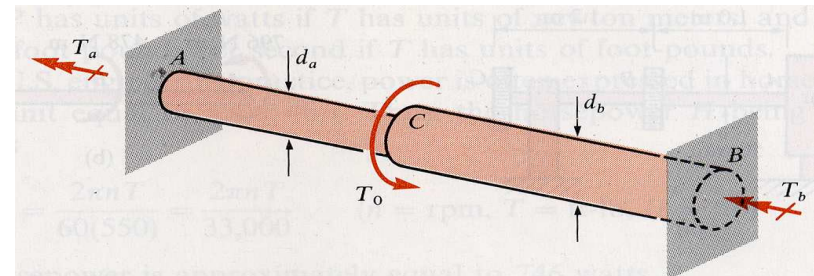

Statically Indeterminate Torsional Members: Nonuniform Shaft

- Compatibility condition

$$\phi_b = \phi_{ac} - \phi_{cb} = 0 \rightarrow \text{because end B is fixed}$$

$$\phi_b = \frac{T_0 a}{GI_{pa}} - \frac{T_b a}{GI_{pa}} - \frac{T_b b}{GI_{pb}} = 0$$

I_p : polar moment of inertia = J

using the compatibility to write T_b as a function of T_0 , then substitute in the equilibrium equation to solve for T_a

$$T_a = T_0 \frac{bI_{pa}}{aI_{pb} + bI_{pa}} \quad \text{and} \quad T_b = T_0 \frac{aI_{pb}}{aI_{pb} + bI_{pa}}$$

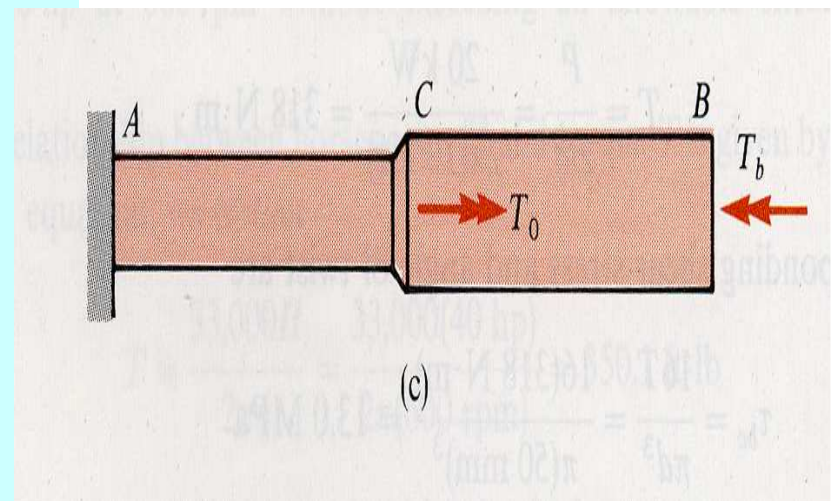

Statically Indeterminate Torsional Members: Composite Shaft

- A composite bar is made of concentric, circular torsional bars that are firmly bonded together to act as a single member.
- If the tube and the core have different materials properties then the bar is statically indeterminate

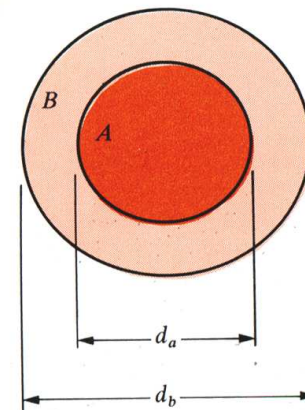
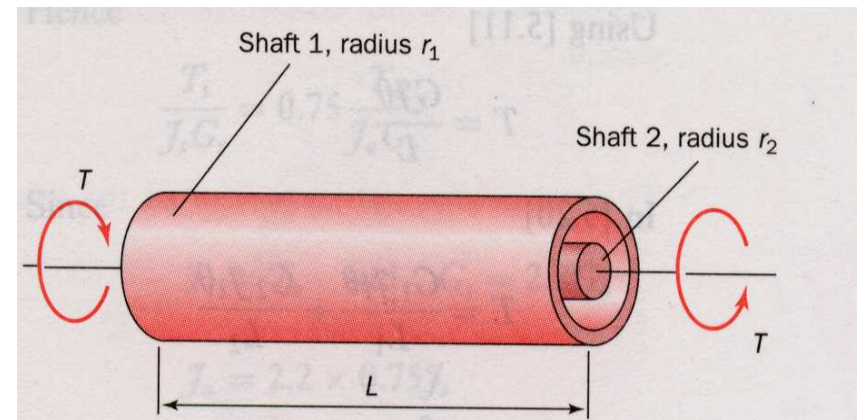

Statically Indeterminate Torsional Members: Composite Shaft

Assuming that the composite bar is acted upon by a total torque T , which is resisted by torques T_a and T_b developed in the core and tube respectively.

$$\text{Equilibrium : } T = T_a + T_b$$

Compatibility : Angle of twist ϕ , must be the same for both

$$\text{parts so they hold together } \phi = \frac{T_a L}{G_a J_a} = \frac{T_b L}{G_b J_b}$$

$$\text{solving } \rightarrow T_a = T \frac{G_a J_a}{G_a J_a + G_b J_b}$$

$$T_b = T \frac{G_b J_b}{G_a J_a + G_b J_b}$$

The angle of twist ϕ

$$\phi = \phi = \frac{T_a L}{G_a J_a} = \frac{T_b L}{G_b J_b} \Rightarrow \frac{TL}{G_a J_a + G_b J_b}$$

Example : Composite Shafts

- A composite aluminum and steel shaft is used to transmit a torque $T=6000\pi$ in.-lb as shown. The two materials are assumed to act as a unit, meaning no relative motion occurs between the aluminum and steel portions at their common interface.
- Determine (a) the resisting torque in the aluminum and in the steel (b) the angle of twist of the free end relative to the fixed end, and (c) the maximum stress in the aluminum and in the steel

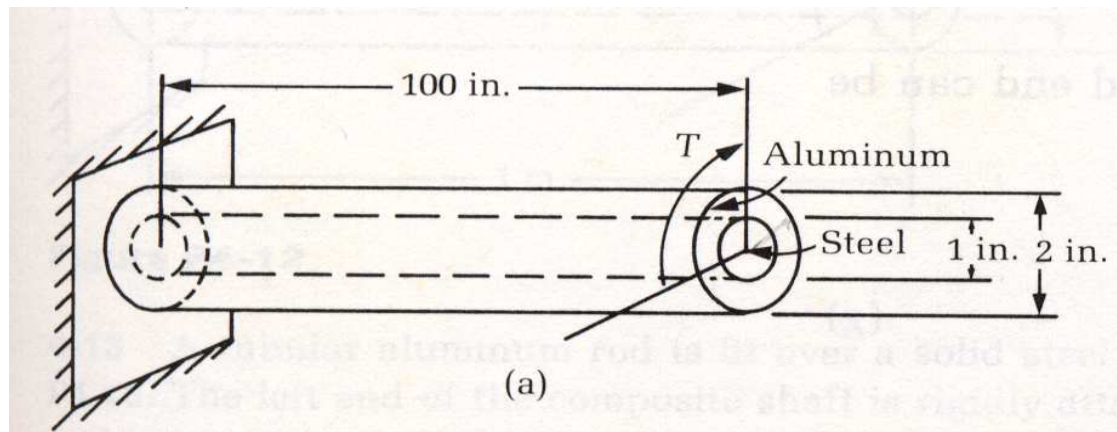

Solution

- Geometric compatibility:

$$\frac{T_{ST} l_{ST}}{J_{ST} G_{ST}} = \frac{T_{AL} l_{AL}}{J_{AL} G_{AL}}$$

so

$$T_{ST} = \frac{J_{ST}}{J_{AL}} \frac{G_{ST}}{G_{AL}} T_{AL}$$

- Now

$$J_{ST} = \frac{\pi}{32} \text{ in}^4 \quad \text{and} \quad J_{AL} = \frac{15\pi}{32} \text{ in}^4$$

So that $J_{ST} / J_{AL} = \frac{1}{15}$, Also

$$\frac{G_{ST}}{G_{AL}} = \frac{12 \times 10^6}{4 \times 10^6} = 3$$

Consequent ly

$$T_{ST} = \frac{1}{5} T_{AL}$$

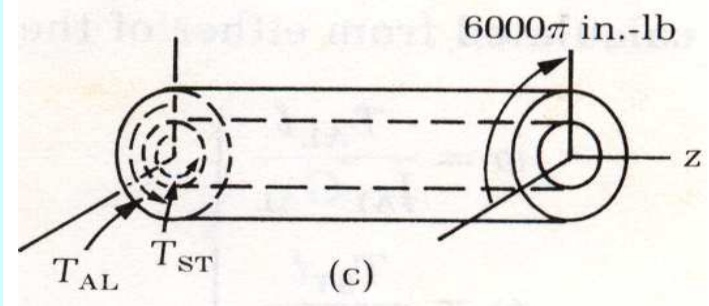
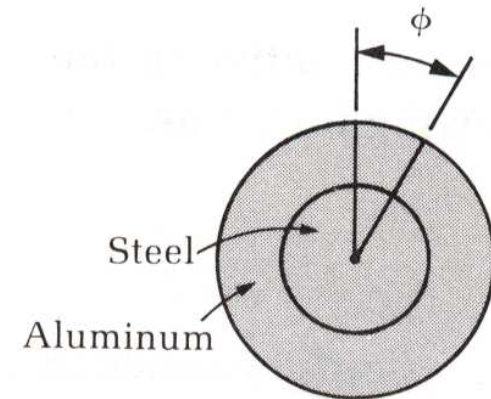

Solution

•Equilibrium:

$$\sum M_Z = 0: \quad T_{AL} + T_{ST} = 6000\pi$$

Solution (a)

$$\left. \begin{aligned} T_{AL} &= 5000\pi \text{ in.} \cdot \text{lb} \\ T_{ST} &= 1000\pi \text{ in.} \cdot \text{lb} \end{aligned} \right\}$$

Solution (b): The angle of twist

$$\left. \begin{aligned} \varphi &= \frac{T_{AL} l}{J_{AL} G_{AL}} \\ \varphi &= \frac{T_{ST} l}{J_{ST} G_{ST}} \end{aligned} \right\}$$

$$\varphi = \frac{5000 \pi (1)}{\frac{15 \pi}{32} (4 \times 10^6)} = 0.267 \text{ rad}$$

Solution, cont..

Solution c: max Shearing stress

$$\tau_{\max} = \frac{5000\pi(1)}{\frac{15\pi}{32}} = 10,667 \text{ psi (aluminum)}$$

$$\tau_{\max} = \frac{1000\pi(0.5)}{\frac{\pi}{32}} = 16000 \text{ psi (steel)}$$

Example: Shaft Design

- A solid alloy shaft of 50mm in diameter is to be friction welded concentrically to the end of a hollow steel shaft of the same external diameter. Find the internal diameter of the shaft if the angle of twist per unit length is to be 75% that of the alloy shaft.
- What is the maximum torque that can be transmitted if the limiting shear stresses in the alloy and the steel are 50MN/m and 75MN/m respectively.
- $G_{\text{steel}} = 2.2G_{\text{alloy}}$

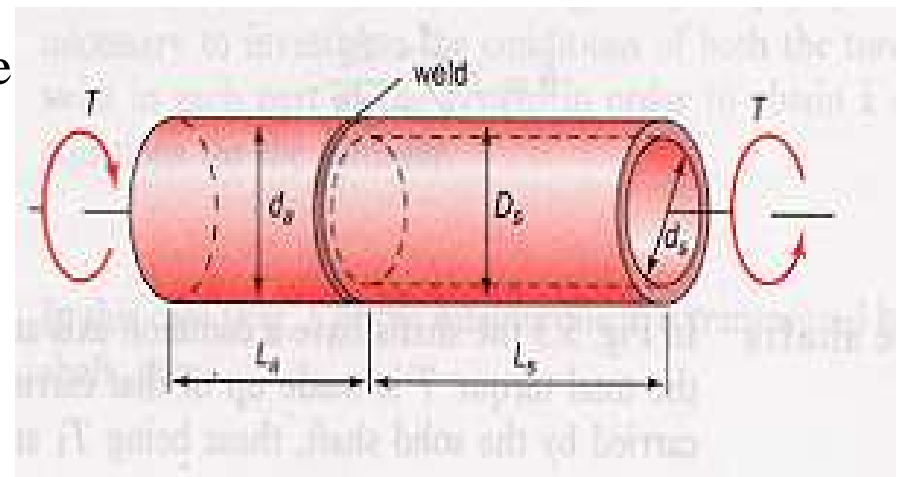

Solution

•Equilibrium:

$$T_{\text{alloy}} = T_{\text{steel}} = T$$

•Geometry of deformation:

$$\frac{\theta_s}{L_s} = 0.75 \frac{\theta_a}{L_a}$$



$$\frac{T_s}{J_s G_s} = 0.75 \frac{T_a}{J_a G_a}$$

Since

$$T_s = T_a \quad \text{and} \quad G_s = 2.2 G_a$$

$$J_a = 2.2 * 0.75 J_s$$

$$\frac{\pi d_a^4}{32} = 2.2 * 0.75 \frac{\pi}{32} (D_s^4 - d_s^4)$$

$$50^4 = (2.2 * 0.75 * 50^4) - (2.2 * 0.75 * d_s^4)$$

$$d_s^4 = \frac{0.65 * 50^4}{2.2 * 0.75}$$

$$d_s = 39.6 \text{ mm}$$

Solution

The torque that can be carried by the alloy is:

$$T = \frac{\pi d^3}{16} \tau = \frac{\pi \times 50^3}{16 * 10^9} * 50 * 10^6 = 1227 \text{ Nm}$$

The torque that can be carried by the steel is:

$$T = \frac{\pi}{16} \frac{(50^4 * 39.6^4)}{50 * 10^9} * 75 * 10^6 = 1120 \text{ Nm}$$

The maximum torque allowable is 1120 N.m

Example: Statically Indeterminate Torsional Element

- The composite shaft consists of a steel section 25mm in diameter and an aluminum section 50mm in diameter. The ends of the shaft are fixed so that rotation cannot occur there.
- Determine (a) the resisting torques exerted by the supports on the shaft and (b) the maximum stress in the aluminum and the max. stress in the steel.

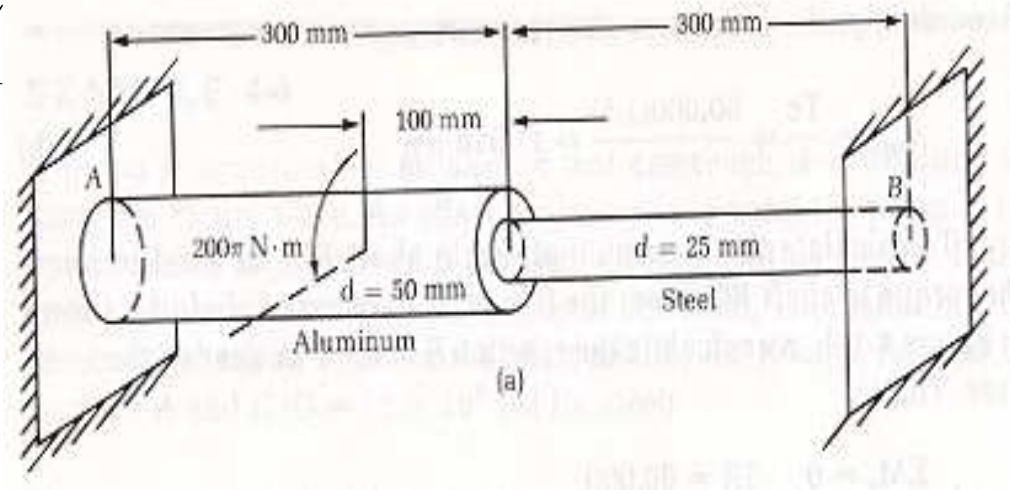

Solution

•Equilibrium:

$$\sum M_Z = 0: \quad T_A + T_B = 200\pi$$

•Geometric compatibility: $\varphi_{A/B} = 0$

$$\varphi_{B/A} = \frac{T_B (0.3)}{\frac{\pi}{32} (0.025)^4 (84 \times 10^9)} + \frac{T_B (0.3)}{\frac{\pi}{32} (0.05)^4 (28 \times 10^9)} - \frac{200 \pi (0.2)}{\frac{\pi}{32} (0.05)^4 (28 \times 10^9)}$$

Fulfilling the compatibility condition we find T_B , then from equilibrium we find T_A

$$T_B = 21.05 \pi N * m$$

$$T_A = 178.95 \pi N * m$$

•Finally; using the Torsion formula, we find the max shearing stresses

$$(\tau_{AL})_{\max} = \frac{(178.95 \pi)(0.025)}{\frac{\pi}{32} (0.05)^4} = 22.90 \text{ MPa}$$

$$(\tau_{ST})_{\max} = \frac{(21.05 \pi)(0.0125)}{\frac{\pi}{32} (0.025)^4} = 21.55 \text{ MPa}$$

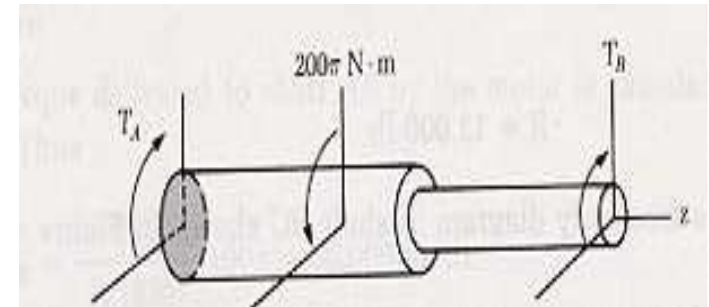

Example: Torque

- A circular shaft rigidly clamped at its left end and free to rotate in a frictionless bearing at its right end. A 16 in diameter pulley and a 12 in. Diameter pulley are keyed to the shaft as shown. Cables attached to the pulleys exert the forces shown.
- The internal or resisting torque T_R is required for the intervals $(0 < z < 2)$ and $(2 < z < 6)$.

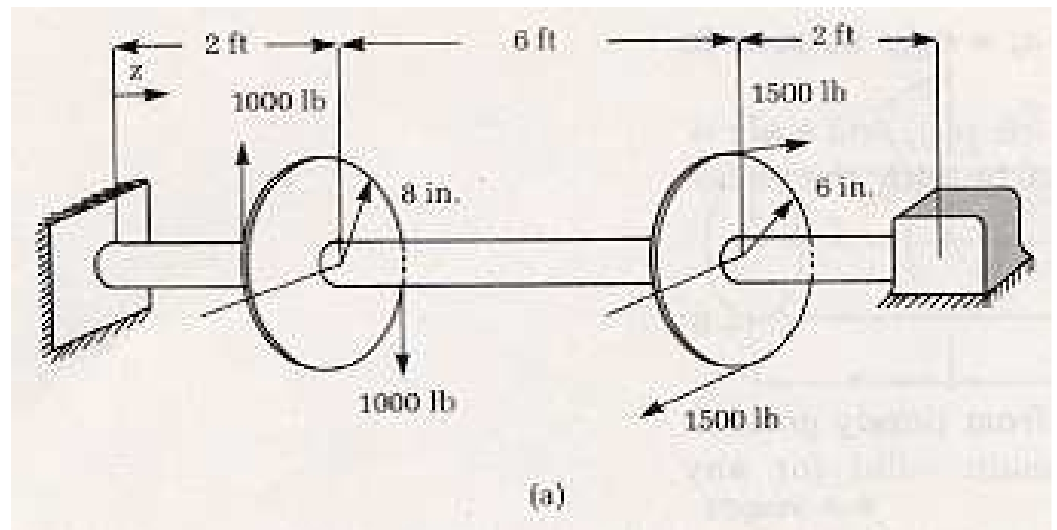

Solution

FB-diagram

Find the reactions:

For $0 \leq z \leq 2$

$$\sum M_z = 0: T_R - 1000(16) - 1500(12) = 0$$

or

$$T_R = 34000 \text{ in.} \cdot \text{lb}$$

For $2 \leq z \leq 6$

$$\sum M_z = 0: T_R - 1500(12) = 0$$

or

$$T_R = 18000 \text{ in.} \cdot \text{lb}$$

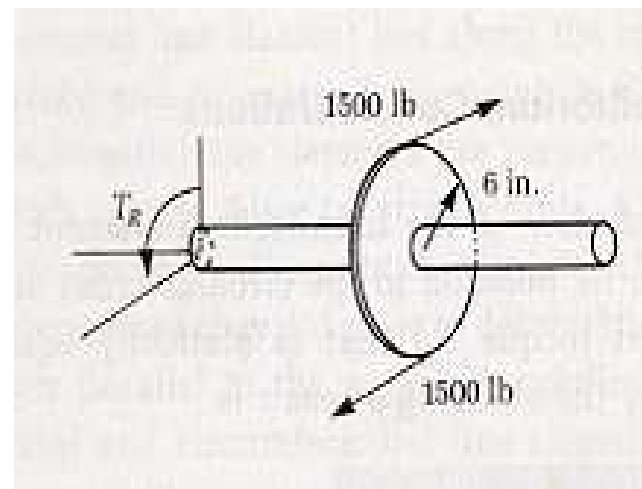
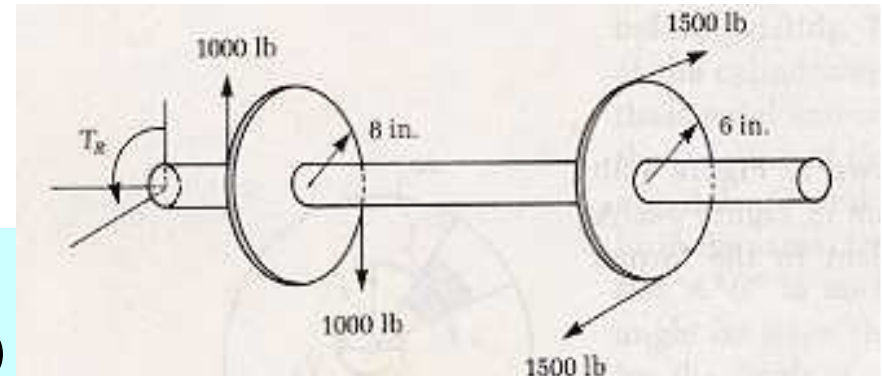

Example

- Determine the maximum shear stress and rate of twist of the given shaft if a 10 kN.m torque is applied to it.
- If the length of the shaft is 15 m, how much would it rotate by? Let $G = 81 \text{ GPa}$, $D = 75 \text{ mm}$

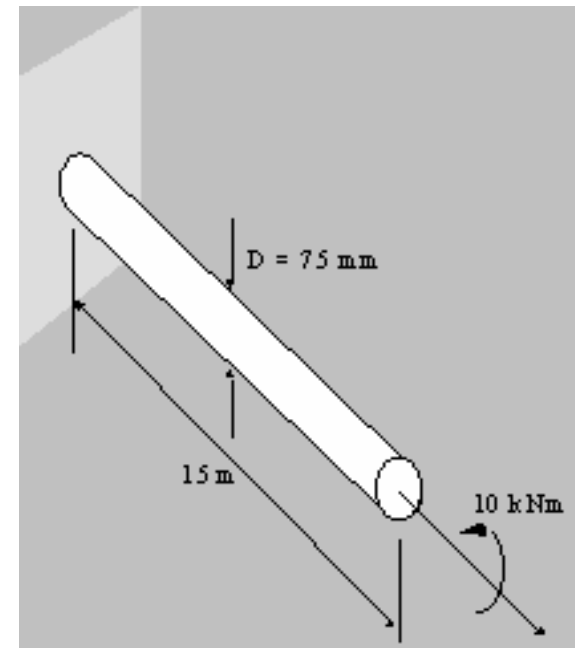

Answer

$$J = \frac{\pi D^4}{32} = \frac{\pi (0.075)^4}{32} = 3.106 \times 10^{-6} m^4$$

$$\tau = \frac{T \cdot r}{J} = \frac{10 \times 10^3 \times .00375}{3.106 \times 10^{-6}} = 120.7 MPa$$

$$\frac{d\theta}{dx} = \frac{T}{GJ} = \frac{10 \times 10^3}{81 \times 10^9 \times 3.106 \times 10^{-6}} = 0.03974 \text{ rad / m}$$

Example: Power Transmission

- A pump is connected to an electric motor through steel shafting as shown. An offset necessary to connect the pump to its power source is provided by the gear arrangement as shown.
- If the motor delivers 100π HP at 330rpm at its shaft, determine (a) the maximum shearing stress in the shaft and (b) the relative rotation of sections A and C.
- $G=12*10^6$ psi for steel

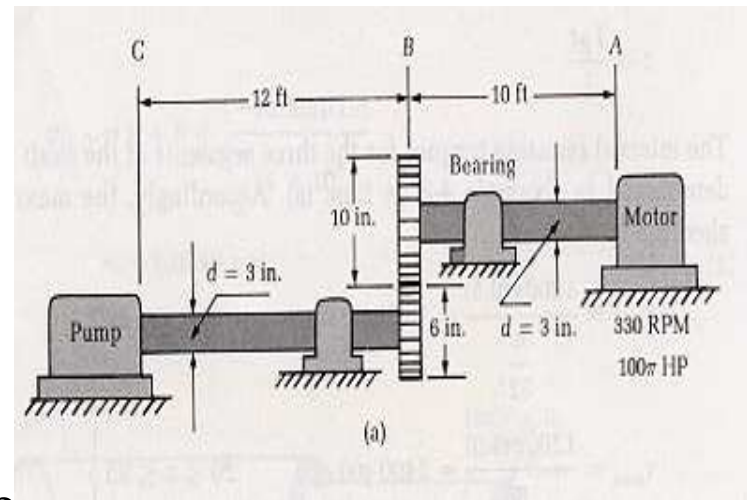

Solution

$$T_{AB} = \frac{550(12)60}{2\pi(330)} 100\pi = 60000 \text{ in.-lb}$$

$$\tau_{\max} = \frac{T_C}{J} = \frac{60000 (1.5)}{7.952} = 11318 \text{ psi}$$

Calculate R:

$$\begin{aligned} \sum M_Z = 0: \quad 5R &= 60000 \\ R &= 12000 \text{ lb} \end{aligned}$$

From FBD:

$$\sum M_Z = 0: \quad T_{BC} = 12000(3) = 36000 \text{ in.-lb}$$

$$\tau_{\max} = \frac{36000(1.5)}{7.952} = 6791 \text{ psi}$$

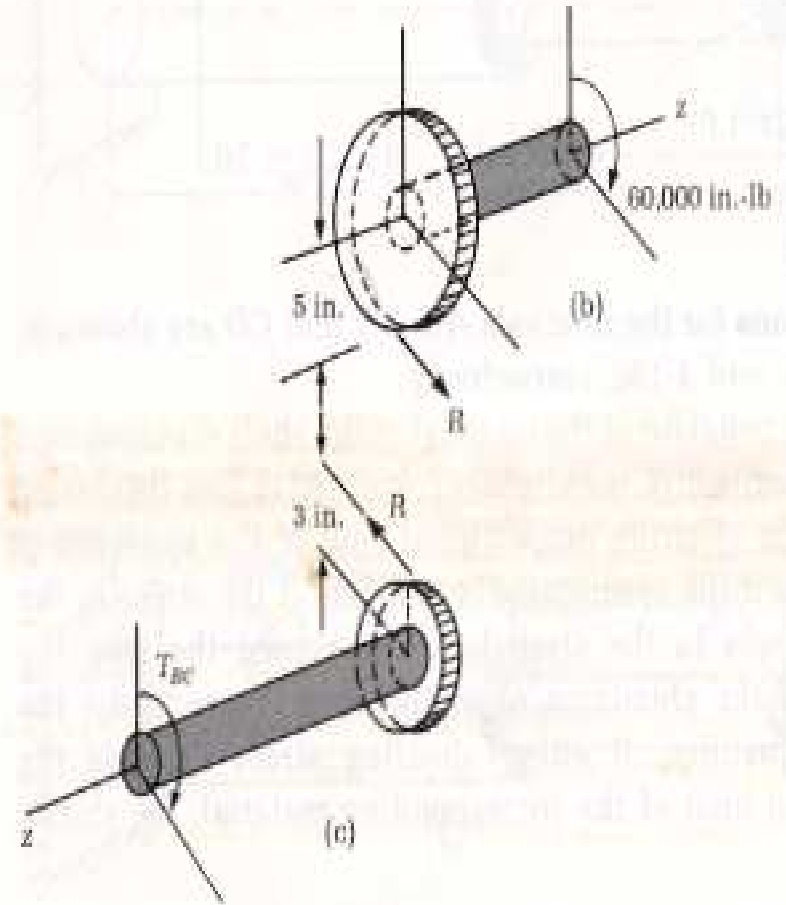

Solution

$$\varphi_{A/C} = \varphi_{A/B} + \varphi$$

$$\varphi_{A/B} = \frac{T_{AB} l_{AB}}{JG} = \frac{60000(120)}{7.952(12 \times 10^6)} = 0.07545 \text{ rad}$$

and $5\varphi = 3\varphi_{BC}$, where $\varphi_{BC} = \frac{T_{BC} l_{BC}}{JG}$

$$\varphi = \frac{3}{5} \frac{36000(144)}{7.952(12 * 10^6)} = 0.03259 \text{ rad}$$

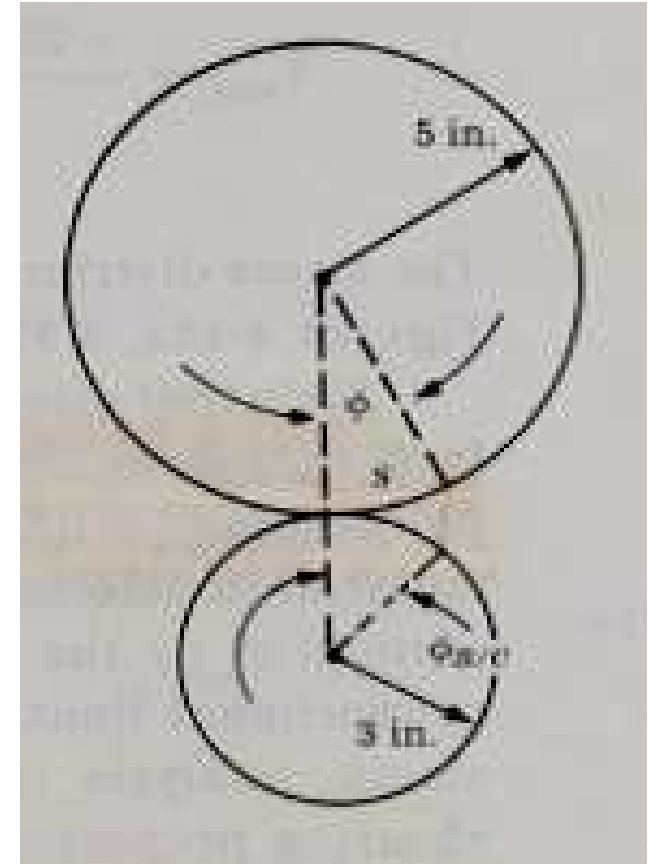

$$\varphi_{AC} = 0.074545 + 0.03259 = 0.108 \text{ rad} = 6.19 \text{ deg}$$

Example: Shaft Design

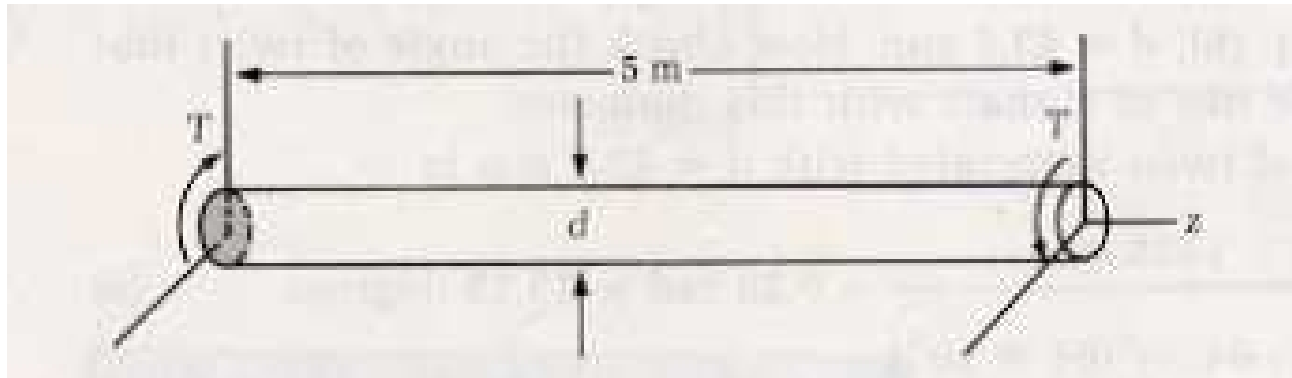

- The steel shaft shown is required to transmit 20π HP at 5.5Hz. If the allowable angle of twist per meter of the shaft is not to exceed 4.5 degrees, and if the allowable shearing stress is not to exceed 84MPa, calculate the minimum permissible diameter.

Solution

The torque that the shaft must transmit is

$$T = \frac{P}{2\pi f} = \frac{745.7(20\pi)}{2\pi(5.5)} = 1355.8 \text{ N.m}$$

Strength requirement|:
from the design criteria

$$\tau_{allow} = \frac{Tc}{J} \Rightarrow 84 \times 10^6 = \frac{1355.8(d/2)}{\frac{\pi}{32}d^4}$$

Stiffness requirement: We calculate the diameter such that the allowable angle of twist is not to be exceeded

allowable angle of twist per unit length = 4.5 deg = 0.07854 rad

$$\phi_{allow} = 5 \times 0.07854 \text{ rad}$$

$$\phi = \frac{TL}{JG} \Rightarrow 0.07854 \times 5 = \frac{1355.8 \times 5}{\frac{\pi}{32}d^4 \times 10^6} \Rightarrow d = 38 \text{ mm}$$

Hence, the minimum permissible diameter is 43.5 mm

Example: Nonuniform Torsion

- A solid steel shaft ABCD having diameter $d=3\text{in.}$ turns freely in a bearing at D and is loaded at B and C by torques $T_1=20\text{in.-kips}$ and $T_2=12\text{in.-kips}$. The shaft is connected in the gear box at A to gears that are temporarily locked in position.
- Determine the maximum shear stress in each part of the shaft and the angle of twist at and D.
- Assume $L_1 = 20\text{in.}$, $L_2 = 30\text{in.}$, $L_3 = 20\text{in.}$, and $G=11500\text{ksi}$

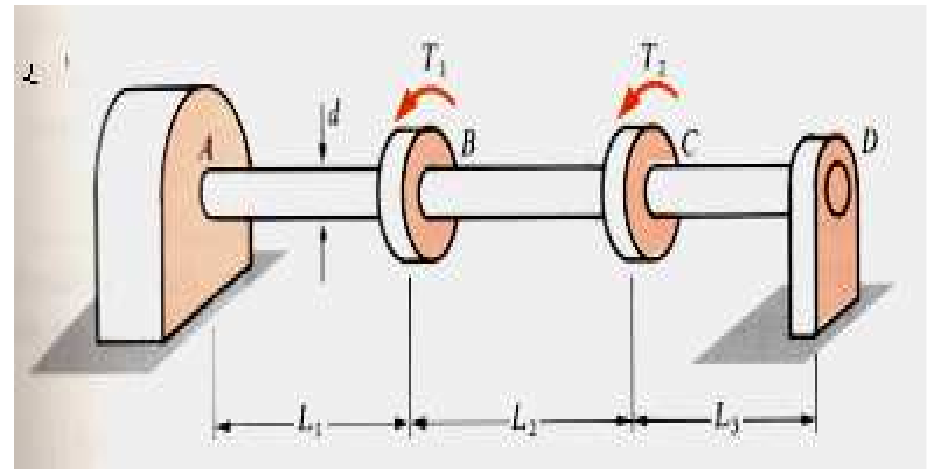

Solution

First find the torque in each part of the shaft

$$T_{ab} = T_1 + T_2 = 32\text{in.} \cdot \text{kips}$$

$$T_{bc} = T_2 = 12\text{in.} \cdot \text{kips}$$

$$T_{cd} = 0$$

•The corresponding maximum stresses are as follows:

$$\tau_{ab} = \frac{16T_{ab}}{\pi d^3} = \frac{16(32000 \text{ in.} \cdot \text{lb})}{\pi(3.0\text{in.})^3} = 6040 \text{ psi}$$

$$\tau_{bc} = \frac{16T_{bc}}{\pi d^3} = \frac{16(12000 \text{ in.} \cdot \text{lb})}{\pi(3.0\text{in.})^3} = 2260 \text{ psi}$$

$$\tau_{cd} = 0$$

•The angle of twist:

$$\begin{aligned}\phi &= \sum_{i=1}^n \frac{T_i L_i}{G_i I_i} = \frac{1}{GI_p} (T_{ab} L_1 + T_{bc} L_2 + T_{cd} L_3) \\ &= \frac{1}{(11500 \text{ ksi})(\pi/32)(3.0\text{in.})^4} [(32\text{in.} \cdot \text{k})(20\text{in.}) + (12\text{in.} \cdot \text{k})(30\text{in.}) + 0] \\ &= 0.0109 \text{ rad} = 0.627^\circ\end{aligned}$$

Example: Nonuniform Torsion

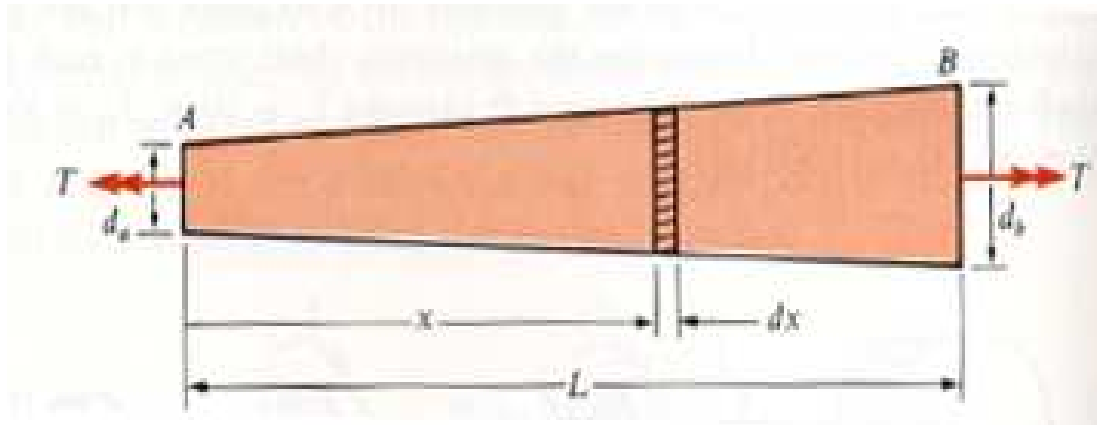

- A tapered bar AB of solid circular cross-section is twisted by torques T applied at the ends. The diameter of the bar varies uniformly from d_a on the left end to d_b on the right end.
- Derive the formula for the angle of twist of the bar.

Solution

- Diameter d_x at distance x from end A is:

$$d_x = d_a + \frac{d_b - d_a}{L} x$$

- The polar moment of inertia:

$$I_{px} = \frac{\pi d_x^4}{32} = \frac{\pi}{32} \left(d_a + \frac{d_b - d_a}{L} x \right)^4$$

- With constant T_x
the expression of
the angle of twist
becomes

$$\begin{aligned} \phi &= \int_0^L \frac{T dx}{GJ} \\ &= \frac{32TL}{3\pi G(d_b - d_a)} \left(\frac{1}{d_a^3} - \frac{1}{d_b^3} \right) \end{aligned}$$

Example: Nonuniform Shaft

- A step-shaft constructed from aluminum ($G=12 \times 10^6$ psi) bar stock carries the torsional loads shown.
- Determine the angle of twist of the section at A relative to the section at D. Assume that all materials behave in a linearly elastic manner.
- Solve using (a) discrete element procedure and, (b) the superposition procedure.

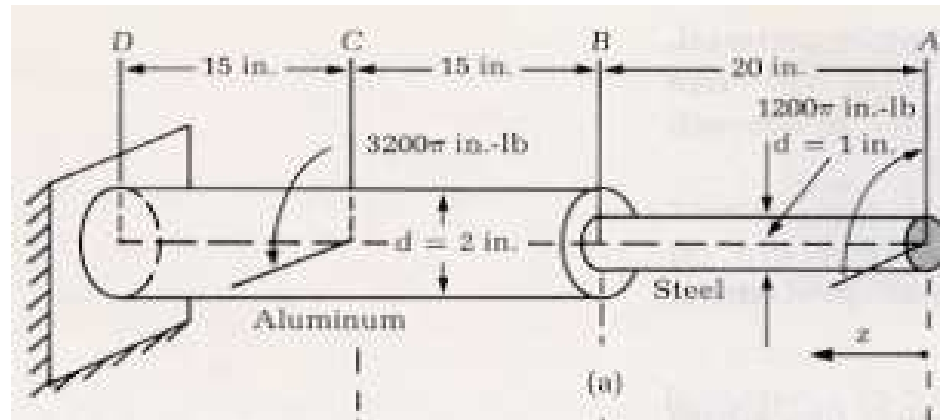

Solution: Discrete Element Procedure

$$\begin{aligned}
 \varphi_{A/D} &= \varphi_{A/B} + \varphi_{B/C} + \varphi_{C/D} \\
 &= \frac{(1200\pi)20}{\frac{\pi}{32}(12 \times 10^6)} + \frac{(1200\pi)15}{\frac{\pi}{2}(4 \times 10^6)} + \frac{(-2000\pi)15}{\frac{\pi}{2}(4 \times 10^6)} \\
 &= 0.0640 + 0.0090 - 0.0150 \\
 &= 0.058 \text{ rad} \\
 &= 3.323 \text{ degrees}
 \end{aligned}$$

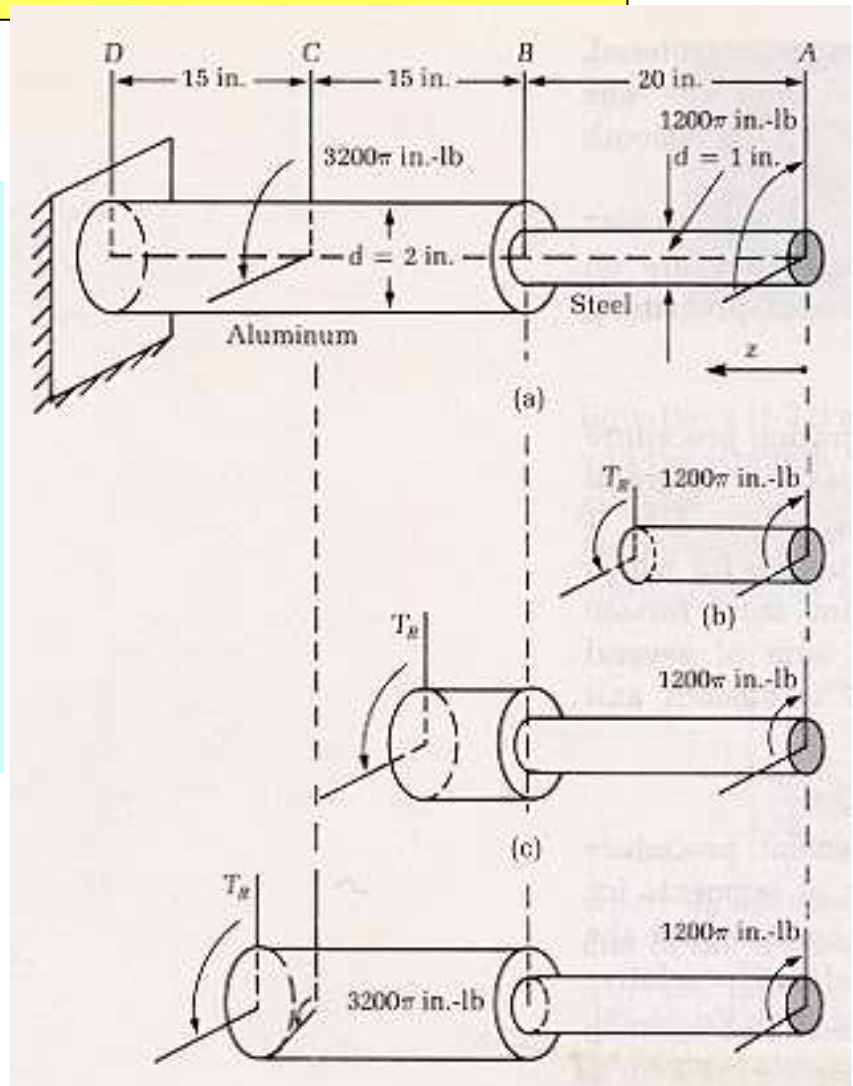

Solution : Superposition Principle

$$\begin{aligned}\phi'_{A/D} &= \frac{(1200\pi)20}{\frac{\pi}{32}(12 \times 10^6)} + \frac{(1200\pi)30}{\frac{\pi}{2}(4 \times 10^6)} \\ &= 0.0640 + 0.0180 \\ &= 0.082 \text{ rad}\end{aligned}$$

$$\begin{aligned}\phi''_{A/D} &= 0 + 0 + \frac{(-3200\pi)15}{\frac{\pi}{2}(4 \times 10^6)} \\ &= -0.0240 \text{ rad}\end{aligned}$$

$$\phi'_{A/D} + \phi''_{A/D} = 0.082 - 0.024 = 0.058 \text{ rad}$$

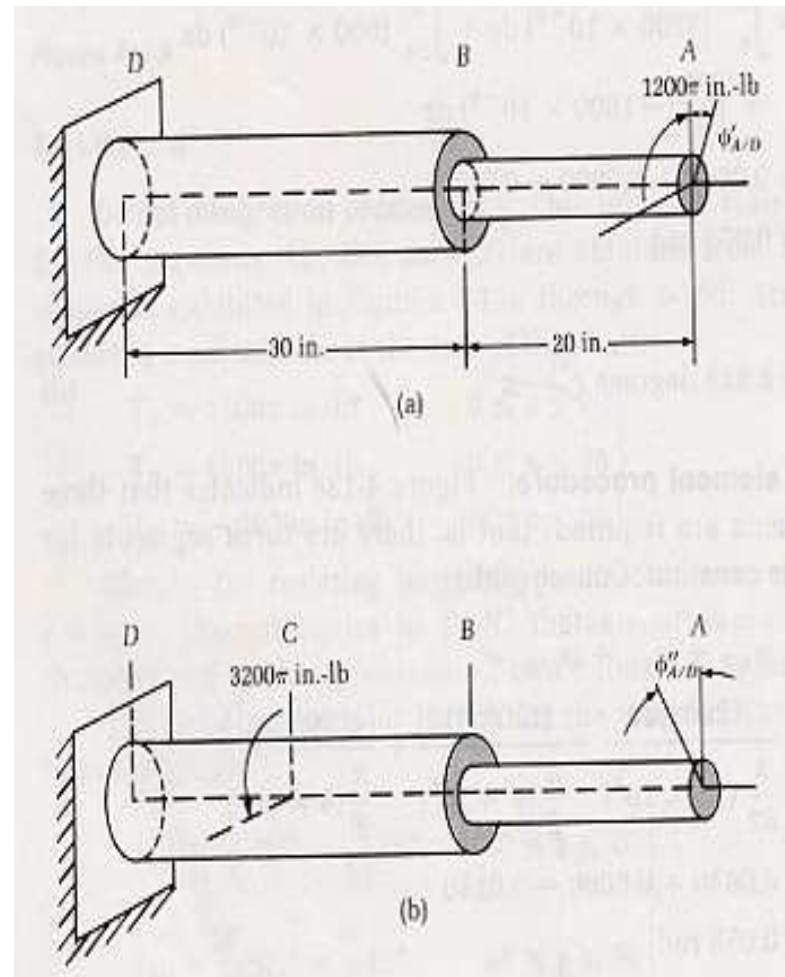

Example Torsion Formula

- Calculate the maximum shearing stress that occurs at any point in each of the three segments AB, BC, and CD of the shaft in the previous Example.

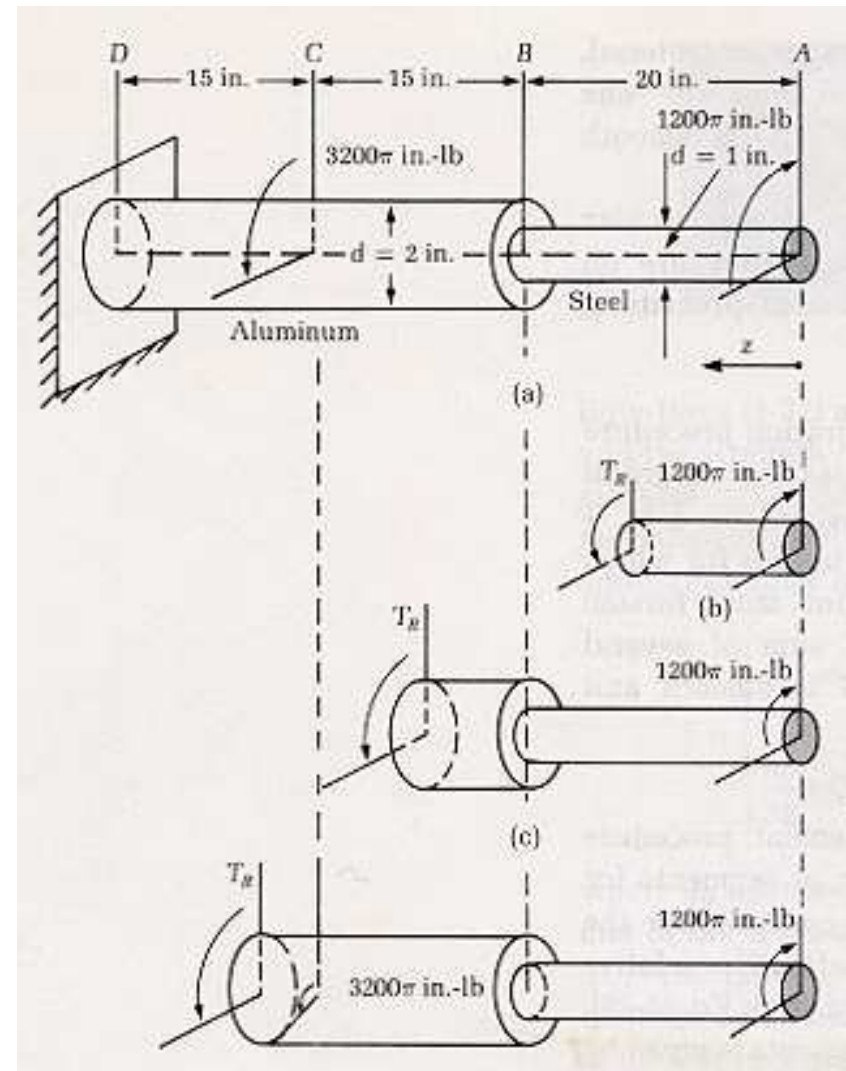

Solution

$$\tau = \frac{T_R r}{J}$$

$$\tau_{\max} = \frac{1200\pi(0.5)}{\frac{\pi}{32}} = 19200 \text{ psi} \quad 0 \leq z \leq 20$$

$$\tau_{\max} = \frac{1200\pi(1.0)}{\frac{\pi}{2}} = 2400 \text{ psi} \quad 20 \leq z \leq 35$$

$$\tau_{\max} = \frac{-2000\pi(1.0)}{\frac{\pi}{2}} = -4000 \text{ psi} \quad 35 \leq z \leq 50$$

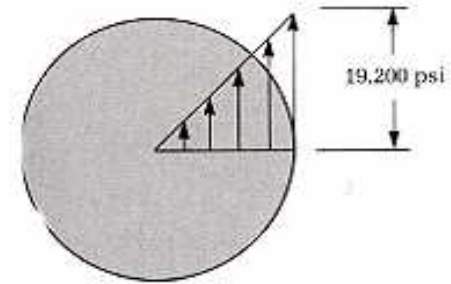

(a)

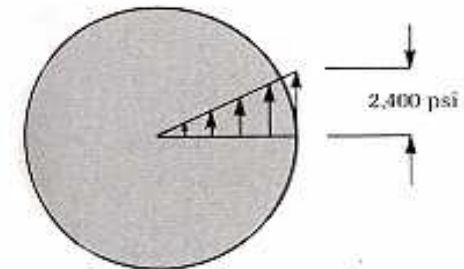

(b)

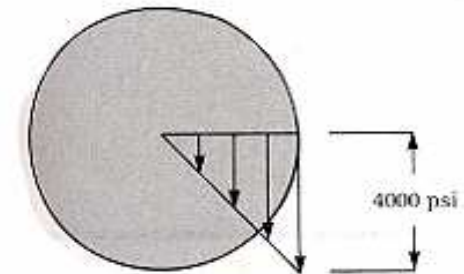

(c)

Example: Statically Indeterminate Torsional Element

- The composite shaft consists of a steel section 25mm in diameter and an aluminum section 50mm in diameter. The ends of the shaft are fixed so that rotation cannot occur there.
- Determine (a) the resisting torques exerted by the supports on the shaft and (b) the maximum stress in the aluminum and the max. stress in the steel.

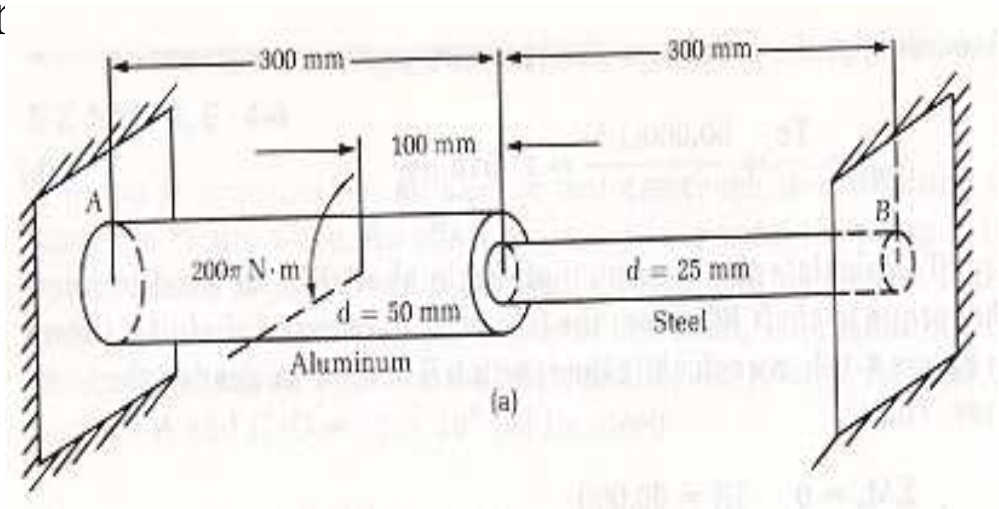

Solution

- Equilibrium:

$$\sum M_Z = 0: \quad T_A + T_B = 200\pi$$

- Geometric compatibility: $\varphi_{A/B} = 0$

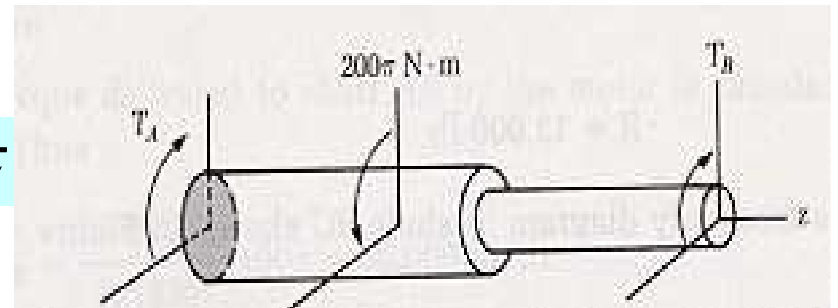

$$\varphi_{B/A} = \frac{T_B (0.3)}{\frac{\pi}{32} (0.025)^4 (84 \times 10^9)} + \frac{T_B (0.3)}{\frac{\pi}{32} (0.05)^4 (28 \times 10^9)} - \frac{200 \pi (0.2)}{\frac{\pi}{32} (0.05)^4 (28 \times 10^9)}$$

Fulfilling the compatibility condition we find T_B , then from equilibrium we find T_A

$$T_B = 21.05 \pi N * m$$

$$T_A = 178.95 \pi N * m$$

- Finally; using the Torsion formula, we find the max shearing stresses

$$(\tau_{AL})_{\max} = \frac{(178.95 \pi)(0.025)}{\frac{\pi}{32} (0.05)^4} = 22.90 \text{ MPa}$$

$$(\tau_{ST})_{\max} = \frac{(21.05 \pi)(0.0125)}{\frac{\pi}{32} (0.025)^4} = 21.55 \text{ MPa}$$